

SCAG[®]

GIANT-VAC[®]

OPERATOR'S MANUAL

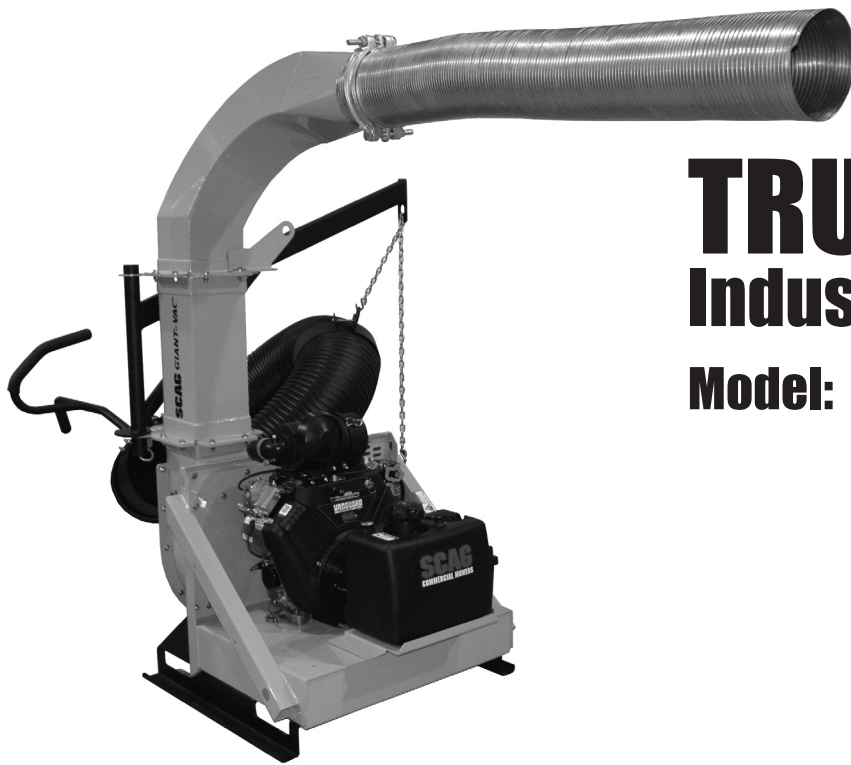

TRUCK LOADER

Industrial Skid Mount

Model: TLS20W-29BV

Congratulations on owning a Scag Giant-Vac truck loader! This manual contains the operating instructions and safety information for your Scag Giant-Vac truck loader. Reading this manual can provide you with assistance in maintenance and adjustment procedures to keep your truck loader performing to maximum efficiency. The specific models that this book covers are listed on the inside cover. Before operating your truck loader, please read all the information enclosed.



WARNING

FAILURE TO FOLLOW SAFE OPERATING PRACTICES MAY RESULT IN SERIOUS INJURY OR DEATH.

- Read this manual completely as well as other manuals that came with your truck loader.
- ALWAYS FOLLOW OSHA APPROVED OPERATION.
- Become familiar with the safe operation of the equipment, operator controls and safety signs.
- Keep all shields and guards securely in place.
- Be sure all safety features are attached, adjusted and functioning properly.
- Before performing any maintenance or service, stop the machine and remove the spark plug wire.
- If a mechanism becomes clogged, stop the engine and wait for all moving parts to stop before cleaning.
- Keep hands, feet and clothing away from power-driven parts.

REMEMBER - YOUR TRUCK LOADER IS ONLY AS SAFE AS THE OPERATOR!

HAZARD CONTROL AND ACCIDENT PREVENTION ARE DEPENDENT UPON THE AWARENESS, CONCERN, PRUDENCE, AND PROPER TRAINING OF THE PERSONNEL INVOLVED IN THE OPERATION, TRANSPORT, MAINTENANCE, AND STORAGE OF THE EQUIPMENT.

This manual covers the operating instructions and illustrated parts list for:

TLS20W-29BV

with a serial number of

008A00001 to 008A99999

Always use the entire serial number listed on the serial number tag when referring to this product.

Table of Contents

SECTION 1 - GENERAL INFORMATION	1
1.1 INTRODUCTION.....	1
1.2 DIRECTION REFERENCE	1
1.3 SERVICING THE ENGINE AND DRIVE TRAIN COMPONENTS.....	1
1.4 SYMBOLS	2
SECTION 2 - SAFETY INFORMATION	3
2.1 INTRODUCTION.....	3
2.2 SIGNAL WORDS	3
2.3 BEFORE OPERATION CONSIDERATIONS.....	3
2.4 OPERATION CONSIDERATIONS.....	5
2.5 MAINTENANCE CONSIDERATIONS & STORAGE	6
2.6 USING A SPARK ARRESTOR.....	6
2.7 SPARK IGNITION SYSTEM	6
2.8 SAFETY AND INSTRUCTIONAL DECALS	7
SECTION 3 - SPECIFICATIONS	8
3.1 ENGINE	8
3.2 IMPELLER	8
3.3 WEIGHTS AND DIMENSIONS	8
SECTION 4 - OPERATING INSTRUCTIONS	10
4.1 CONTROLS AND INSTRUMENT IDENTIFICATION	10
4.2 SAFETY INTERLOCK SYSTEM	11
4.3 INITIAL RUN-IN PROCEDURES.....	11
4.4 STARTING THE ENGINE	11
4.5 OPERATION	11
4.6 HILLSIDE OPERATION.....	12
4.7 AFTER OPERATION	12
4.8 REMOVING CLOGGED MATERIAL	13
SECTION 5 - MAINTENANCE	14
5.1 MAINTENANCE CHART - RECOMMENDED SERVICE INTERVALS	14
5.2 ENGINE OIL	15
5.3 ENGINE FUEL SYSTEM	15
5.4 ENGINE AIR CLEANER.....	15

SECTION 6 - ILLUSTRATED PARTS LIST	16
6.1 SCAG GIANT-VAC APPROVED ATTACHMENTS AND ACCESSORIES.....	16
NOTES.....	17
INTAKE AND DISCHARGE ASSEMBLY	18
IMPELLER ASSEMBLY	20
FUEL SYSTEM AND BATTERY COMPONENTS.....	22
TL20W - TRUCK LOADER DECALS	24
LIMITED WARRANTY - TRUCK LOADERS.....	INSIDE BACK COVER

GENERAL INFORMATION

1.1 INTRODUCTION

Your Scag Giant-Vac product was built to the highest standards in the industry. However, the prolonged life and maximum efficiency of your truck loader depends on you following the operating, maintenance and adjustment instructions in this manual.

If additional information or service is needed, contact your Scag Giant-Vac Dealer.

We encourage you to contact your dealer for repairs. All Scag Giant-Vac dealers are informed of the latest methods to service this equipment and provide prompt and efficient service in the field or at their service shop. They carry a full line of Scag Giant-Vac service parts.

- IMPORTANT -

The replacement of any part on this product by other than the manufacturer's authorized replacement part may adversely affect the performance, durability or safety of this product.

Use of other than original Scag Giant-Vac replacement parts will void the warranty.

When ordering parts, always give the model and serial number of your product. The serial number plate is located on the frame next to the engine.

USE ONLY SCAG GIANT-VAC APPROVED ATTACHMENTS AND ACCESSORIES.

Attachments and accessories manufactured by companies other than Scag Giant-Vac are not approved for use on this machine. See Section 6-1.

WARNING

For pictorial clarity, some illustrations and figures in this manual may show shields, guards or plates open or removed. Under no circumstances should this product be operated without these devices in place.

All information is based upon product information available at the time of approval for printing. Scag Giant-Vac reserves the right to make changes at any time without notice and without incurring any obligation.











1.2 DIRECTION REFERENCE

The "Right" and "Left", "Front" and "Rear" of the machine are referenced from the operator's right and left when in the normal operating position and facing the forward travel direction.

1.3 SERVICING THE ENGINE AND DRIVE TRAIN COMPONENTS

Details regarding the service and repair of the engine are not covered in this manual; only routine maintenance and general service instructions are provided. For service of these components during the limited warranty period, it is important to contact your Scag Giant-Vac dealer or find a local authorized servicing agent of the component manufacturer. Any unauthorized work done on these components during the warranty period may void your warranty.

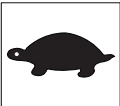
1.4 SYMBOLS

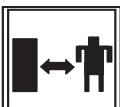
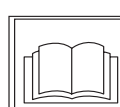
SYMBOL	DESCRIPTION	SYMBOL	DESCRIPTION
	Choke		Transmission
	On/Start		Spring Tension on Idler
	Off/Stop		Oil
	Spinning Fan Blades		Thrown Object Hazard
	Fast		Slow
	Continuously Variable - Linear		Pinch Point
	Keep Bystanders Away		Read Operator's Manual

SAFETY INFORMATION

2.1 INTRODUCTION

Your truck loader is only as safe as the operator. Carelessness or operator error may result in serious bodily injury or death. Hazard control and accident prevention are dependent upon the awareness, concern, prudence, and proper training of the personnel involved in the operation, transport, maintenance and storage of the equipment. Make sure every operator is properly trained and thoroughly familiar with all of the controls before operating. The owner/user can prevent and is responsible for accidents or injuries occurring to themselves, other people or property.

READ THIS OPERATOR'S MANUAL BEFORE ATTEMPTING TO START YOUR TRUCK LOADER.

A replacement manual is available from your authorized Scag Giant-Vac Dealer or by contacting Scag Giant-Vac Service Department at P.O. Box 152, Mayville, WI 53050 or contact us via the Internet at www.giant-vac.com. The manual for this machine can be downloaded by using the model and serial number or use the contact form to make your request. Please indicate the complete model and serial number of your Scag Giant-Vac product when requesting replacement manuals.

2.2 SIGNAL WORDS



This symbol means "**Attention! Become Alert! Your Safety is Involved!**" The symbol is used with the following signal words to attract your attention to safety messages found on the decals on the machine and throughout this manual. The message that follows the symbol contains important information about safety. To avoid injury and possible death, carefully read the message! Be sure to fully understand the causes of possible injury or death.

SIGNAL WORD:

It is a distinctive word found on the safety decals on the machine and throughout this manual that alerts the viewer to the existence and relative degree of the hazard.

DANGER

The signal word "DANGER" denotes that an extremely hazardous situation exists on or near the machine that could result in high probability of death or irreparable injury if proper precautions are not taken.

WARNING

The signal word "WARNING" denotes that a hazard exists on or near the machine that can result in injury or death if proper precautions are not taken.

CAUTION

The signal word "CAUTION" is a reminder of safety practices on or near the machine that could result in personal injury if proper precautions are not taken.

Your safety and the safety of others depends significantly upon your knowledge and understanding of all correct operating practices and procedures of this machine.

2.3 BEFORE OPERATION CONSIDERATIONS

1. Check the engine oil level and add oil as needed to bring the level up to the FULL mark. See engine owner's manual for oil specifications.
2. NEVER allow children to operate this machine. Do not allow adults to operate this machine without proper instructions.
3. Keep bystanders, children and pets away from the machine.
4. Do not operate when children and/or others are present. Keep children out of the work area and in the watchful care of a responsible adult other than the operator. Be alert and turn machine off if a child enters the area.
5. DO NOT allow children to ride or play on the machine, it is not a toy.

6. DO NOT operate the machine under the influence of alcohol or drugs.
7. Before and during reverse operation, look behind and down for small children and/or pets.
8. If the operator(s) or mechanic(s) cannot read English, it is the owner's responsibility to explain this material to them.
9. DO NOT wear loose fitting clothing. Loose clothing, jewelry or long hair could get tangled in moving parts. Do not operate the machine wearing shorts; always wear adequate protective clothing including long pants. Wearing safety glasses, safety shoes and a helmet is advisable and is required by some local ordinances and insurance regulations.

 **WARNING**

Always wear hearing protection. Operating this machine over prolonged periods of time can cause loss of hearing.

10. Keep the machine and attachments in good operating condition. Keep all shields and safety devices in place. If a shield, safety device or decal is defective or damaged, repair or replace it before operating the machine.

 **WARNING**

Belts, belt guards, hoses, intake nozzles and discharge tubes are subject to wear, damage and/or deterioration, which could expose moving parts or allow objects to be thrown. Frequently check components and replace with manufacturer's recommended parts when necessary.

11. Thoroughly inspect the area where the equipment is to be used and remove all foreign objects.
12. Evaluate the terrain to determine what accessories and attachments are needed to properly and safely perform the job. Use only approved attachments and accessories.
13. See Section 5.3 ENGINE FUEL SYSTEM for fueling procedure.
14. Use a funnel or spout to prevent spillage.
15. Never refuel indoors.

16. Keep flammable objects (cigarettes, matches, etc.), open flames and sparks away from the fuel tank and fuel container. Use only approved containers.

 **WARNING**

Fuel is highly flammable. Take the following precautions:

Store fuel in containers specifically designed for this purpose.

Refuel outdoors only and do not smoke while refueling.

Add fuel before starting the engine. Never remove the cap on the fuel tank or add fuel while the engine is running or when the engine is hot.

If fuel is spilled, do not attempt to start the engine but move the machine away from the area of spillage and avoid creating any source of ignition until fuel vapors have disappeared.

Replace all fuel tank and container caps securely.

17. Check the inlet hose, discharge, debris receiver box and components frequently for signs of wear or deterioration and replace as needed to prevent injury from thrown objects going through weak or torn spots.
18. Never attempt to make any adjustments while the engine is running unless specifically recommended by the manufacturer.
19. Check the engine mounting bolts at frequent intervals for proper tightness.

Section 2

2.4 OPERATION CONSIDERATIONS

1. Know the function of all controls and how to stop quickly in case of an emergency.
2. Do not carry passengers. Keep bystanders, children and pets away from the machine.
3. Make sure the hose and boom are secured before transporting your Truck Loader.
4. Do not operate without the discharge connected to a debris receiver box.
5. Do not overload the machine by attempting to chip or shred any material beyond the manufacturer's recommendation.
6. Do not operate on slopes if you are uneasy or uncertain. Ultimate responsibility for safe operation on slopes rests with the operator.
7. Exercise extreme caution when making turns or changing direction on slopes. Keep all movements slow and gradual.
8. Slow down and use caution when making turns and crossing roads and side walks.
9. Be sure of your footing. Poor footing could cause a slip and fall accident.
10. When using this machine, never direct the material being collected toward bystanders or allow anyone near the machine while in operation.
11. Do not operate around cars, windows, or other items which could be damaged by blown debris.
12. Before attempting to start the engine, inspect the machine, inlet hose, discharge, debris receiver box, shields and safety devices for any damage. Correct any problems before operating.
13. Stop on level ground and shut off the engine before leaving the operator's position for any reason including emptying the debris box or clearing an obstruction in the intake or discharge.
14. If the truck loader ever plugs, shut off the engine, and wait for all movement to stop before removing the obstruction.
15. If the machine begins to vibrate abnormally, shut the machine off immediately. Inspect the machine and have repairs made before restarting.
16. Be alert for holes, rocks, roots and other hidden hazards in the terrain. Cautiously enter a new area. Be alert for hidden hazards.
17. Do not operate near drop-offs, ditches or embankments. You could lose your footing, balance or drive the machine off the edge.
18. Use only in daylight or good artificial light.
19. Do not leave the machine unattended.
20. The machine and attachments should be stopped and inspected for damage after striking a foreign object, and damage should be repaired before restarting and operating the machine.
21. Keep hands and feet away from blower intake and discharge. Contact can injure.

WARNING

DO NOT use your hand to dislodge the clogged material. Use a stick or other device to remove clogged material after the engine has stopped running and the blower fan has stopped turning.

CAUTION

Do not touch the engine or the muffler while the engine is running or immediately after stopping. These areas may be hot enough to cause a burn.

DANGER

DO NOT run the engine inside a building or a confined area without proper ventilation. Exhaust fumes are hazardous and contain carbon monoxide which can cause brain injury and death.

22. Keep hands and feet away from all other moving parts. Contact can injure.
23. Use care when approaching blind corners, shrubs, trees, or other objects that may obscure vision.
24. NEVER leave the machine running unattended.

2.5 MAINTENANCE CONSIDERATIONS & STORAGE

1. Check impeller on a regular basis for bent, worn or cracked blades. Only replace impellers. Do not straighten or weld the impeller fan.
2. Never make adjustments to the machine with the engine running unless specifically instructed to do so. If the engine is running, keep hands, feet, and clothing away from moving parts.
3. Disconnect spark plug wire to prevent accidental starting of the engine when servicing or adjusting the machine. Wait for all movement to stop before adjusting, cleaning or repairing.
4. Keep all nuts, bolts and screws tight, especially the impeller bolt, to ensure the machine is in safe working condition.
5. Do not change the engine governor settings or overspeed the engine. See the engine operator's manual for information on engine settings.
6. To reduce fire hazard, keep the muffler and engine free of grass, leaves, excessive grease, oil and dirt.
7. Store the machine on level ground.
8. NEVER allow untrained personnel to service the machine.
9. Keep all parts in good working condition. Replace all worn or damaged decals.
10. Use jack stands to support components when required.
11. Let the engine cool before storing.
12. Keep the unit locked in a secure location and disconnect the battery to prevent unauthorized personnel, especially children, from playing and/or tampering with the unit.
13. DO NOT store the machine near an open flame.
14. Always follow the engine manufacturer's recommendation for storing and returning to service.
15. Shut off fuel while storing or transporting.

2.6 USING A SPARK ARRESTOR

The engine on this machine may not be equipped with a spark arrestor muffler. It is in violation of California Public Resource Code Section 4442 to use or operate this engine on or near any forest covered, brush covered or grass covered land unless the exhaust system is equipped with a spark arrestor meeting any applicable local or state laws. Other states or federal areas may have similar laws. Check with your state or local authorities for regulations pertaining to these requirements.

2.7 SPARK IGNITION SYSTEM

This spark ignition system complies with Canadian ICES-002.

Section 2

2.8 SAFETY AND INSTRUCTIONAL DECALS

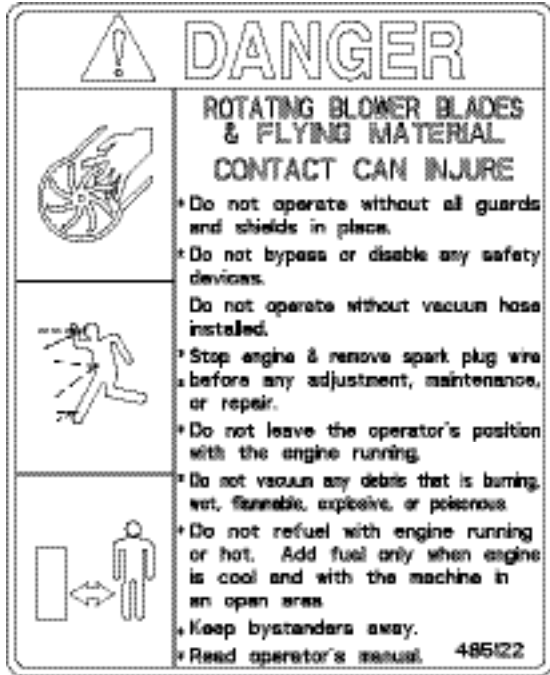

485122

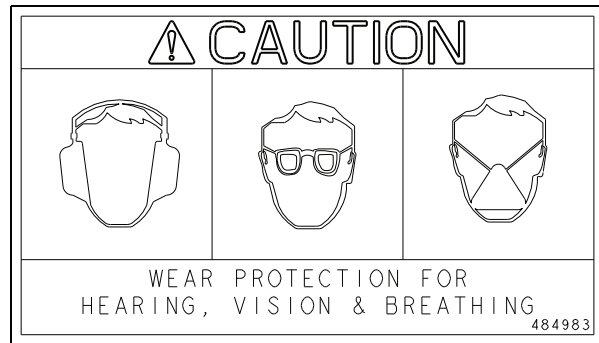

484983



485139

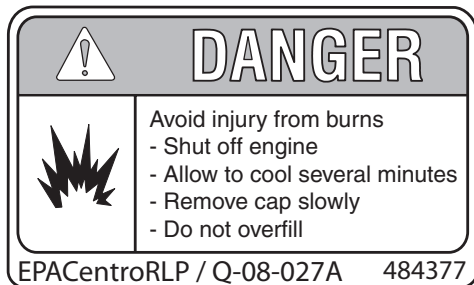

Molded Into Fuel Tank

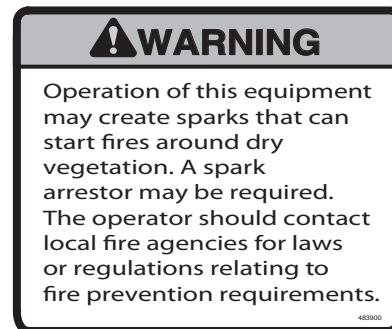

483900
California Only

SPECIFICATIONS

3.1 ENGINE

General TypeHeavy Duty Industrial/Commercial Gasoline
Model:
Scag Giant-Vac Model TL20-29BVBriggs & Stratton Vanguard
Displacement:
Briggs & Stratton 896cc
Type:
Briggs & Stratton 4-Cycle, Air-Cooled, Naturally Aspirated, OHV
Cylinders..... 2 with Cast Iron Sleeves
Governor.....Mechanical Type with Variable Speed Control Set At 3300 RPM
Idle Speed:
Briggs & Stratton 1750 RPM
Carburation:
Briggs & Stratton Fixed Jet Sidedraft Carburetor
Fuel Pump:
Briggs & Stratton Mechanical with In-Line Fuel Filter
Fuel..... Non-Leaded Gasoline with a Minimum Octane Rating of 87
Oil Pump..... Full Pressure w/Full-Flow Filter
Starter..... Electric Starting with Solenoid Shift

3.2 IMPELLER

Impeller Diameter Balanced 20" Steel with Tapered Locking Hub
Number of Blades..... 4 - Blade, 3/8"
CFM (cubic feet / min.) TBD
Wear Liner 1/4" Steel
Intake Hose 10' x 12"
Discharge 5' x 8"

3.3 WEIGHTS AND DIMENSIONS

Discharge Height77"
Weight 675#

OPERATING INSTRUCTIONS

CAUTION

Do not attempt to operate this machine unless you have read this manual. Learn the location and purpose of all controls and instruments before you operate.

4.1 CONTROLS AND INSTRUMENT IDENTIFICATION

Before operating the truck loader, familiarize yourself with all truck loader and engine controls. Knowing the location, function and operation of these controls is important for safe and efficient operation.

1. **Ignition Switch (Figure 4-1).** The ignition switch is used to start the engine and has three positions; OFF, ON, and START.
2. **Engine Throttle Control (Figure 4-1).** Used to control the engine speed. Pushing the lever inboard increases engine speed. Pulling the lever outboard decreases engine speed. Full outboard position is the IDLE position. Full inboard is the operating position.
3. **Engine Choke Control (Figure 4-1).** Used to start a cold engine.
4. **Fuel Shutoff Valve (Figure 4-1).** Located under the fuel tank. Used to shut off fuel supply to the engine. Rotate the valve counter clockwise to supply fuel. Rotate the valve clockwise to shut off fuel supply.

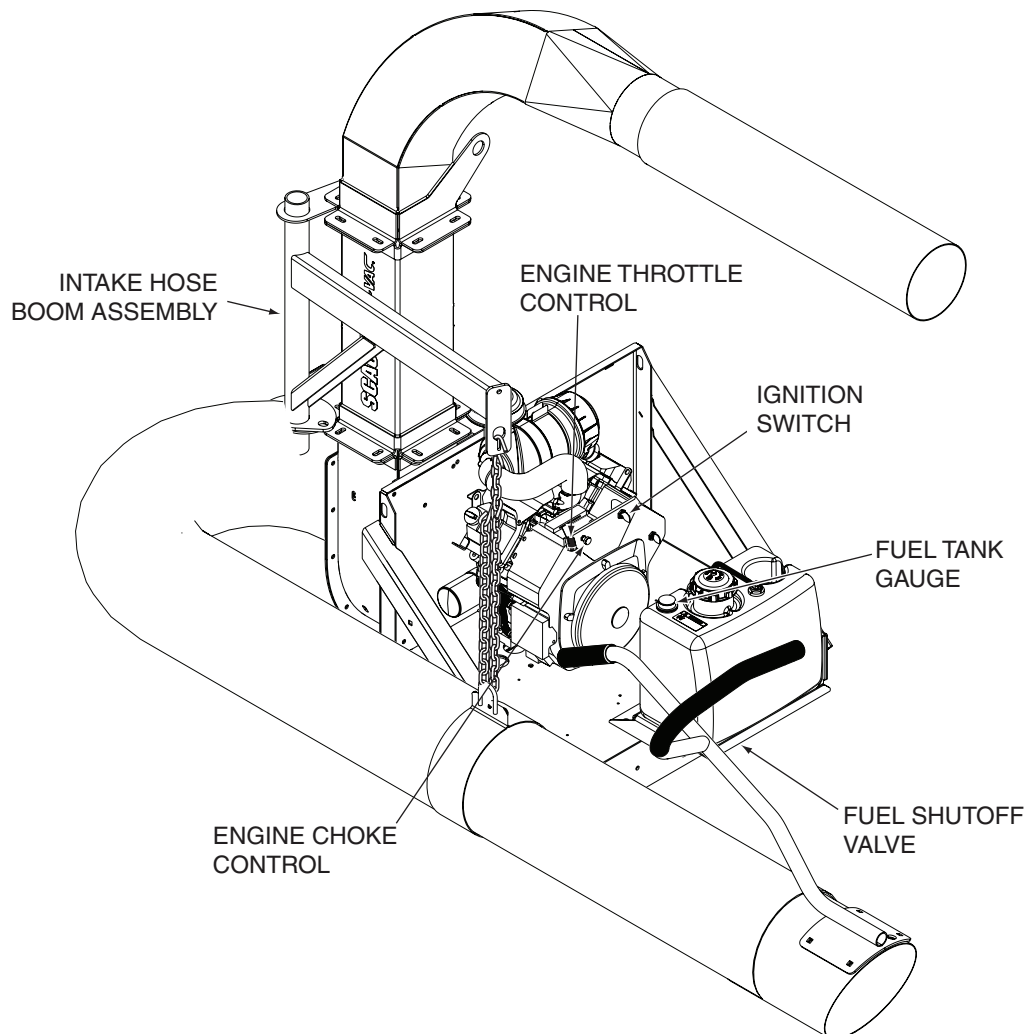

Figure 4-1. Controls and Instruments - TLH Model Shown

Section 4

5. **Intake Hose Boom Assembly (Figure 4-1).** Used to support the intake hose. The support chain can be raised or lowered until the intake nozzle floats 2-3 inches from the ground to help make operation easy and comfortable.

4.2 SAFETY INTERLOCK SYSTEM

The truck loader is equipped with a safety interlock system that prevents the engine from starting unless the intake hose assembly is attached to the truck loader. If the intake hose assembly is removed, the impeller door will close and the interlock system will shut off the engine.

WARNING

Never operate the truck loader with the interlock system disconnected or malfunctioning. Do not disengage or bypass any switch; injury to yourself and others or property damage could result.

4.3 INITIAL RUN-IN PROCEDURES

FIRST DAY OF USE OR APPROXIMATELY 20 HOURS

1. Change the engine oil and oil filter after the first 20 hours of operation. (See Section 5.2).
2. Check for loose hardware. Tighten as needed.
3. Check tire pressure. Adjust pressure if necessary. (See Section 5.5).

4.4 STARTING THE ENGINE

CAUTION

DO NOT USE STARTING FLUIDS. Use of starting fluids in the air intake system may be potentially explosive or cause a "runaway" engine condition that could result in engine damage and/or personal injury.

1. Move the machine to a flat open area.
2. Be sure the fuel shutoff valve, located under the fuel tank, is completely open. See Figure 4-1.

3. Move the engine throttle control to about half engine speed. If starting a cold engine, move the engine control all the way forward to engage the choke.
4. Turn the ignition key to the START position and release the key as soon as the engine starts. Do not hold the key in the START position for more than 15 seconds at a time. Allow at least 60 seconds between each cranking attempt to prevent overheating of the starter motor. Prolonged cranking can damage the starter motor and shorten battery life.
5. Allow engine to warm before operating the truck loader.

4.5 OPERATION

This truck loader has been designed to pick up dry organic debris such as leaves, grass clippings, shavings and small amounts of sand. Vacuuming hard non-organic material will affect the life of your machine. Sand is abrasive and will produce wear of items including the blower housing, impeller and bag adapter.

WARNING

DO NOT operate the machine without being attached to a debris box. Always wear eye, ear and breathing protection when operating machine.

1. Read Section 2.3 BEFORE OPERATION CONSIDERATIONS and Section 2.4 OPERATION CONSIDERATIONS before operating.
2. Adjust the height of the intake nozzle. For maximum debris pickup, the intake nozzle should be as close to the debris as possible without blocking airflow and the engine speed should be set to "Fast".
3. Not all debris pick up will require that the engine speed be set to "Fast". You can experiment with the intake nozzle height and engine speed to best suit your conditions.
4. Operating in dry dusty conditions may require that the engine speed be set to a slower position to reduce the amount of small particles of debris escaping.
5. For peak performance, keep the debris box clean and do not overfill.

6. When operating, instruct the operator to stay to the side of the machine, never in front or behind.

WARNING

DO NOT remove the Truck Loader from the tow vehicle or debris box with the engine running. STOP the engine and allow all rotation to stop.

7. If the intake nozzle or discharge becomes plugged, shut off the engine and remove the spark plug wire. The engine must come to a complete stop before attempting to remove obstruction from inlet nozzle or discharge area. Using a stick or similar item, dislodge the clogged material. Then resume normal operation.
8. Plan how to clear the area to reduce clearing time.
9. Collecting debris into piles for the machine to intercept prior to start up will save time and fuel as well as wear and tear on the unit.
10. Keep the truck loader's intake nozzle and discharge clean.
11. Use a slow travel speed when clearing heavy or large amounts of material.

4.6 HILLSIDE OPERATION

Slopes are a major factor related to loss-of-control and tip over accidents which can result in severe injury or death. All slopes require extra caution.

WARNING

DO NOT operate on steep slopes. Poor footing could cause a slip and fall accident. ALWAYS FOLLOW OSHA APPROVED OPERATION.

1. Do not operate on slopes if you are uneasy or uncertain. Ultimate responsibility for safe operation on slopes rests with the operator.
2. Be sure of footing on slopes.
3. Caution must be used when operating on slopes, especially when the grass is wet. Wet grass reduces traction and control.
4. To prevent tipping or loss of control, keep all movements on slopes slow and gradual.

5. Do not turn on slopes unless necessary, and then turn slowly and down hill when possible.
6. Do not start or stop on slopes. If tires lose traction, stop the unit and proceed slowly straight down the slope.
7. Be alert for holes, rocks, roots, ruts and other hidden hazards in the terrain. Uneven terrain could cause a slip and fall accident.
8. Do not operate near drop-offs, ditches, or embankments. The operator could lose footing or balance or unit could suddenly turn over if a wheel is over the edge of a cliff or ditch, or if the edge caves in.

4.7 AFTER OPERATION

1. When machine is not in operation or in storage, lock the hose support boom and secure hose on the storage pin. Pull and turn the spring latch to lock the pin securing the hose support boom in the transport position. See Figure 4-2 & Figure 4-3.
2. When transporting the truck loader, remove the hose assembly from the unit. The hose assembly can be removed by loosening the two wing nuts and sliding the intake adapter upward. See Figure 4-4.

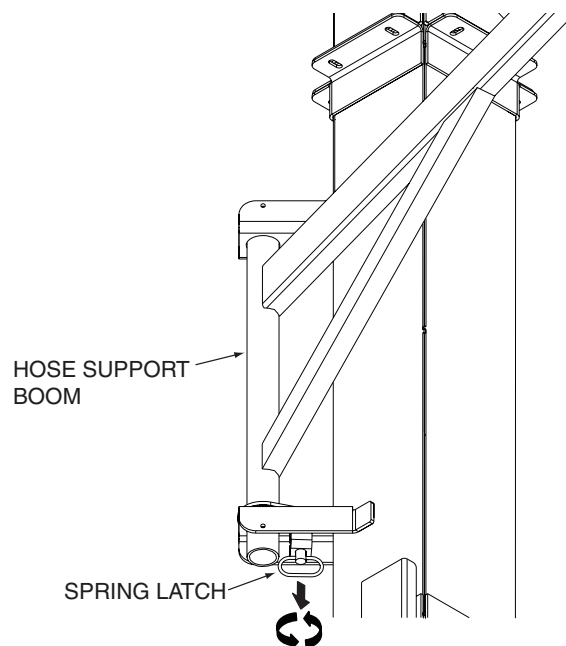

Figure 4-2. Locking the Hose Support Boom

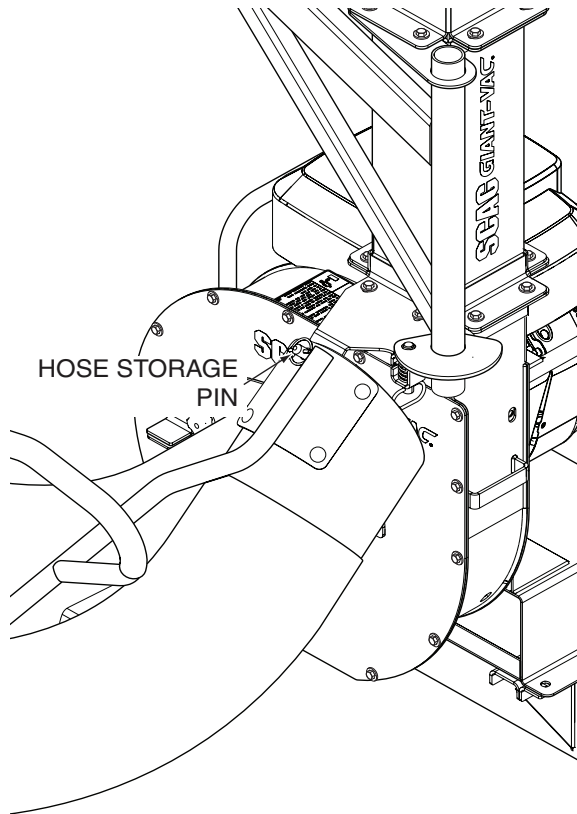

Figure 4-3. Hose Storage Pin

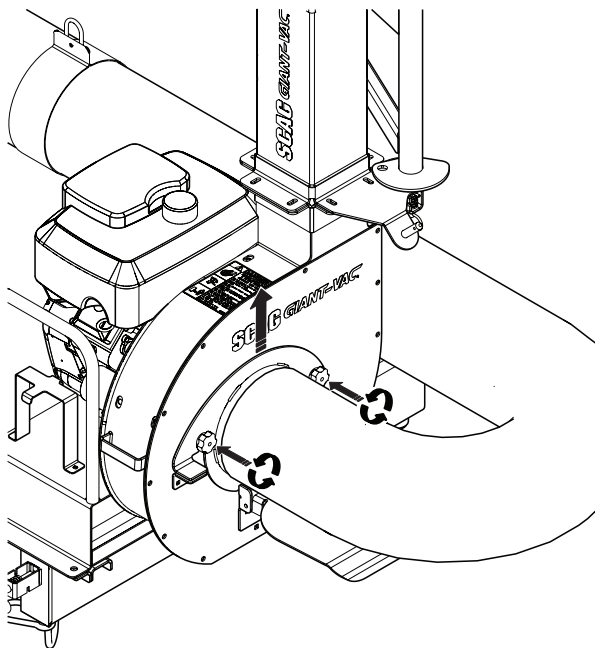

Figure 4-4. Intake Hose Removal

3. After the engine has cooled down, wash the entire machine after each use. Do not use high pressure spray or direct the spray onto electrical components.

- IMPORTANT -

Do not wash a hot or running engine. Cold water will damage the engine. Use compressed air to clean the engine if it is hot.

4. Keep the entire machine clean to inhibit serious heat damage to the engine.

! DANGER

To avoid injury from burns, allow the engine to cool before removing the fuel tank cap and refueling.

4.8 REMOVING CLOGGED MATERIAL

! DANGER

ROTATING FAN BLADES

NEVER PUT YOUR HANDS INTO THE VACUUM INTAKE OR DISCHARGE FOR ANY REASON!

Shut off the engine, remove the spark plug wire and only then use a stick or similar object to remove material if plugging has occurred.

1. If the intake nozzle or discharge becomes plugged, shut off the engine and remove the spark plug wire. The engine must come to a complete stop before attempting to remove obstruction from intake nozzle or discharge area. Using a stick or similar item, dislodge the clogged material. Then resume normal operation.

MAINTENANCE

5.1 MAINTENANCE CHART - RECOMMENDED SERVICE INTERVALS

BREAK-IN (FIRST 10)	HOURS						PROCEDURE	COMMENTS
	8	20	50	100	200	500		
X							Check all hardware for tightness	
	X						Check engine oil level	See engine operator's manual
	X						*Clean truck loader	
	X						Check condition of impeller blades and impeller housing	
	X						Check Safety Interlock System	See Section 4.2
		X					Change engine oil and filter	See engine operator's manual
			X				*Clean air filter element	See engine operator's manual
				X			Check condition of fuel lines	
				X			Check all hardware for tightness	
				X			Change engine oil	See engine operator's manual
				X			*Clean air cleaner element	See engine operator's manual
					X		*Clean Fuel Cup	See engine operator's manual
					X		*Replace engine air filter	See engine operator's manual
					X		Clean and Adjust Spark Plug	See engine operator's manual
						X	Replace Spark Plug	See engine operator's manual

* Perform these maintenance procedures more frequently under extreme dusty or dirty conditions.

Section 5

5.2 ENGINE OIL

A. CHECKING ENGINE CRANKCASE OIL LEVEL

The engine oil level should be checked after every 8 hours of operation or daily as instructed in the Engine Operator's Manual furnished with this truck loader.

B. CHANGING ENGINE CRANKCASE OIL

After the first 20 hours of operation, change the engine crankcase oil and replace the oil filter. Thereafter, change the engine crankcase oil after every 100 hours of operation or bi-weekly, whichever occurs first. Refer to the Engine Operator's Manual furnished with this truck loader for instructions.

5.3 ENGINE FUEL SYSTEM



To avoid injury from burns, allow the engine to cool before removing the fuel tank cap and refueling.

A. FILLING THE FUEL TANK

Fill the fuel tank at the beginning of each operating day. Fill to the bottom of the filler neck insert (approximately 5-1/2 gallons) at the beginning of each operating day. Do not overfill. Use clean, fresh unleaded gasoline with a minimum octane rating of 87 and a maximum of 10% Ethanol.

DO NOT use E85 Fuel. Using E85 Fuel will cause severe damage to the engine.

To avoid personal injury or property damage, use extreme care in handling gasoline. Gasoline is extremely flammable and the vapors are explosive.

1. Extinguish all cigarettes, cigars, pipes and other sources of ignition.
2. Use only an approved gasoline container.
3. Never remove the gas cap or add fuel with the engine running. Allow the engine to completely cool before fueling.

4. Never fuel the machine indoors or in an enclosed trailer.
5. Never store the machine or fuel container where there is an open flame, spark or pilot light such as on a water heater or other appliances.
6. Never fill containers inside a vehicle or on a truck or trailer bed with a plastic liner. Always place containers on the ground away from your vehicle before filling.
7. Remove the machine from the truck or trailer and fuel on level ground. If this is not possible, then refuel the machine with a portable container, rather than from a gasoline dispenser nozzle.
8. Keep the nozzle in contact with the rim of fuel tank or container opening at all times until fueling is complete. Do not use a nozzle lock-open device.
9. If fuel is spilled on clothing, change clothing immediately and wash affected skin.
10. Replace gas cap and tighten securely.

5.4 ENGINE AIR CLEANER

A. CLEANING AND/OR REPLACING AIR CLEANER ELEMENT

For any air cleaner, the operating environment dictates the air cleaner service periods. Inspect and clean the air cleaner element after every 50 hours of operation or monthly, whichever occurs first and replace the element if required or every 200 hours. Refer to the Engine Operator's Manual furnished with this truck loader for instructions.

- NOTE -

In extremely dusty conditions it may be necessary to check the element once or twice daily to prevent engine damage.

ILLUSTRATED PARTS LIST

6.1 SCAG GIANT-VAC APPROVED ATTACHMENTS AND ACCESSORIES.

Attachments and accessories manufactured by companies other than Scag Giant-Vac are not approved for use on this machine.

Scag Giant-Vac approved attachments and accessories:

- Roadside Package (p/n 9xxx) - Includes Wheel Chocks, Wheel Chock Storage Boxes, Cones and Cone Holder
- Truck Loader Light Kit (p/n 9xxx)

NOTES

INTAKE AND DISCHARGE ASSEMBLY

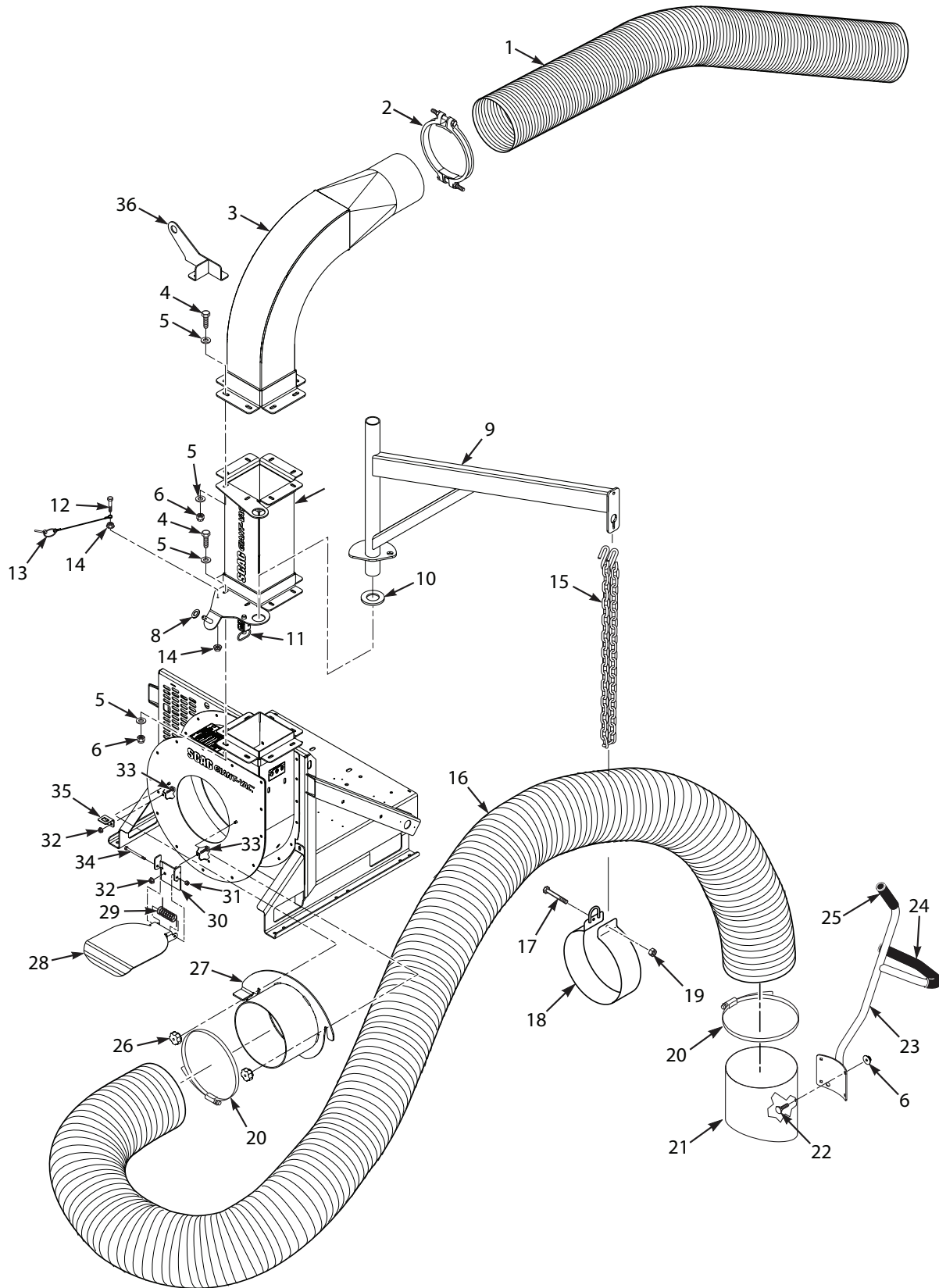

Section 6
INTAKE AND DISCHARGE ASSEMBLY

Ref. No.	Part No.	Description
1	484939-03	Hose, Metal Galv. Interlock 8" Dia. x 60"
2	485060	Clamp, Tube 8" Dia.
3	452479	Elbow, Exhaust - TL20W
4	04001-32	Bolt, Hex Head 3/8-16 x 1-1/4"
5	04041-07	Flatwasher, 3/8-.391 X .938 X .105
6	04021-09	Nut, Elastic Stop 3/8-16
7	462627	Stack, Discharge w/Decals
8	485050	Washer, Rubber
9	452477	Boom Weldment
10	484947	Disc, Anti-Friction
11	485065	Spring
12	04001-59	Bolt, Hex Head 1/4-20 x 1-1/4"
13	485062	Quick Pin Assembly
14	04019-02	Nut, Serrated Flange 1/4-20
15	484894	Chain w/2-Hooks
16	48135-28	Hose, 12" OD x 120" - .045 w/Wearstrip
17	04001-63	Bolt, Hex Head 5/16-18 x 3-1/2"
18	452440	Band, Hose Support
19	04021-10	Nut, Elastic Stop 5/16-18
20	48136-23	Clamp, 12" OD
21	462628	Nozzle, 12"
22	04003-23	Bolt, Carriage 3/8-16 x 1"
23	462612	Handle Assembly w/Grips (incl. # 24 & 25)
24	485076	Grip, 1-1/4 x 20"
25	485075	Grip, 1-1/4 x 6"
26	481185-04	Knob, 3/8-16 Locking
27	452554	Hose Mounting Weldment
28	426461	Safety Switch Door
29	483378	Spring
30	426455	Mounting Bracket, Safety Switch Door
31	04021-10	Nut, Elastic Stop 5/16-18
32	04019-03	Nut, Serrated Flange 5/16-18
33	04003-29	Bolt, Carriage 5/16-18 x 3/4"
34	04001-154	Bolt, Hex Head 5/16-18 x 4-3/4"
35	425388	Bracket, Switch
36	452556	Bracket Weldment, Lift Hook

IMPELLER ASSEMBLY

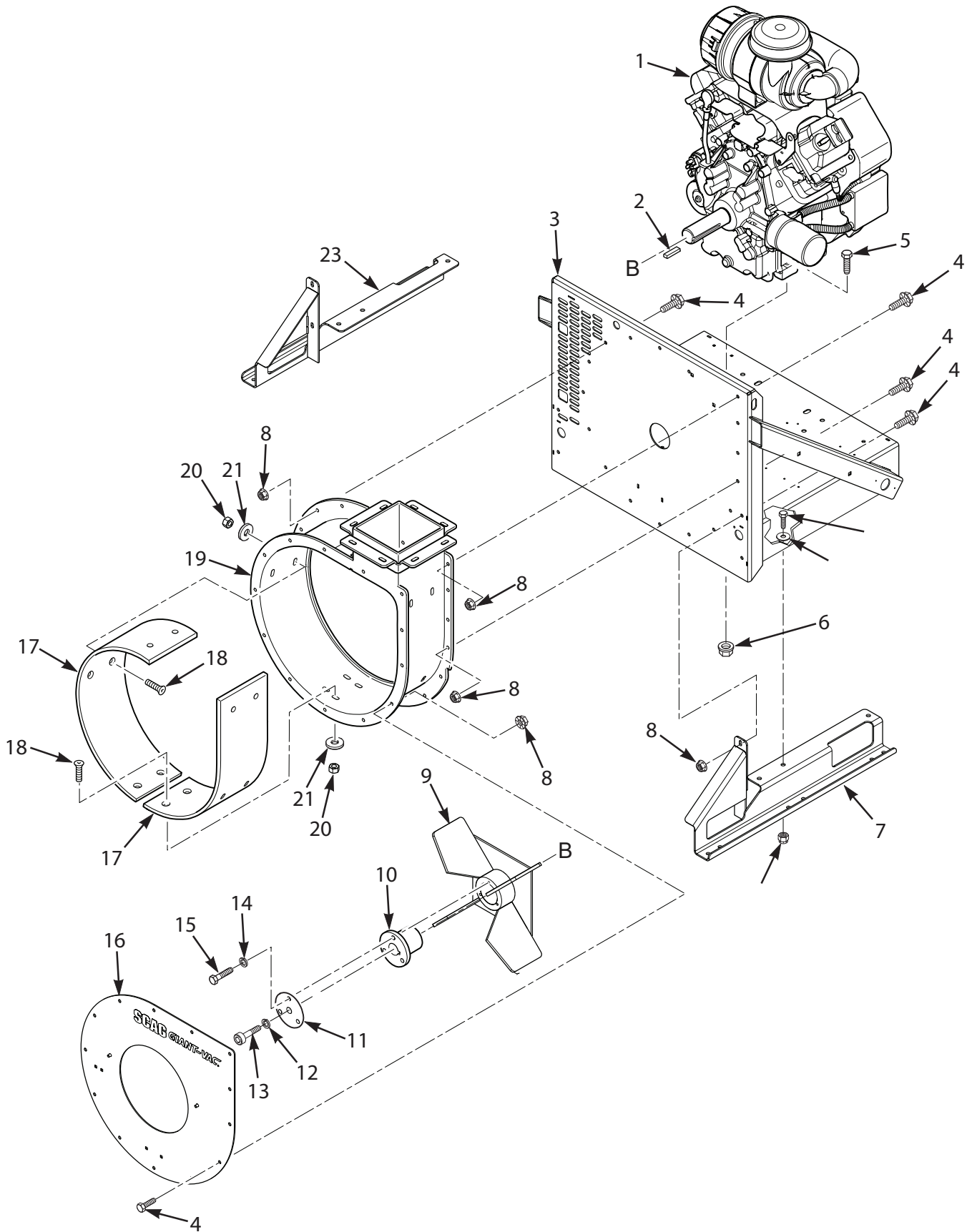

Section 6

IMPELLER ASSEMBLY

Ref. No.	Part No.	Description
1	484957	Engine, 29HP Briggs & Stratton Vanguard (not available through Scag Giant-Vac)
	485003	Muffler, 29hp Briggs & Stratton (not shown)
	485004	Exhaust Manifold, 29hp Briggs & Stratton (not shown)
	485005	Wire Guard, 29hp Briggs & Stratton (not shown)
	426537	Exhaust Deflector (not shown)
2	04063-32	Key, 3/8 x 3/8 x 3-1/2"
3	462651	Frame Weldment w / Decals
4	04017-26	Bolt, Hex Head Serrated Flange 3/8-16 x 3/4"
5	04001-12	Bolt, Hex Head 5/16-18 x 1-3/4"
	04001-17	Bolt, Hex Head 5/16-18 x 2" (LH Front)
6	04019-03	Nut, Serrated Flange 5/16-18
7	452550	Mounting Bracket Weldment, RH Skid
8	04019-04	Nut, Serrated Flange 3/8-16
9	452455	Impeller Weldment, TL20W
10	484820	Hub, Tapered Locking Q2 x 1-7/16"
11	426138	Cover Plate, Hub Taper - TL20W
12	04030-07	Lockwasher, 5/8"
13	04015-22	Socket Head Cap Screw, 5/8-18 x 1-3/4"
14	04030-04	Lockwasher, 3/8"
15	04001-21	Bolt, Hex Head 3/8-16 x 1-3/4"
16	462636	Cover, Housing - TLS20W w/Decal
17	462583	Wearliner Kit w/ Hardware
18	04014-07	Capscrew, 3/8-16 x 1-1/4"
19	462637	Housing Weldment w / Decals
20	04021-09	Nut, Elastic Stop 3/8-16
21	04041-04	Flatwasher, 1/2-.516 x .938 x 12 Ga.
22	452501	Weldment, Exhaust Deflector - 29hp Briggs & Stratton
23	452549	Mounting Bracket Weldment, LH Skid

FUEL SYSTEM AND BATTERY COMPONENTS

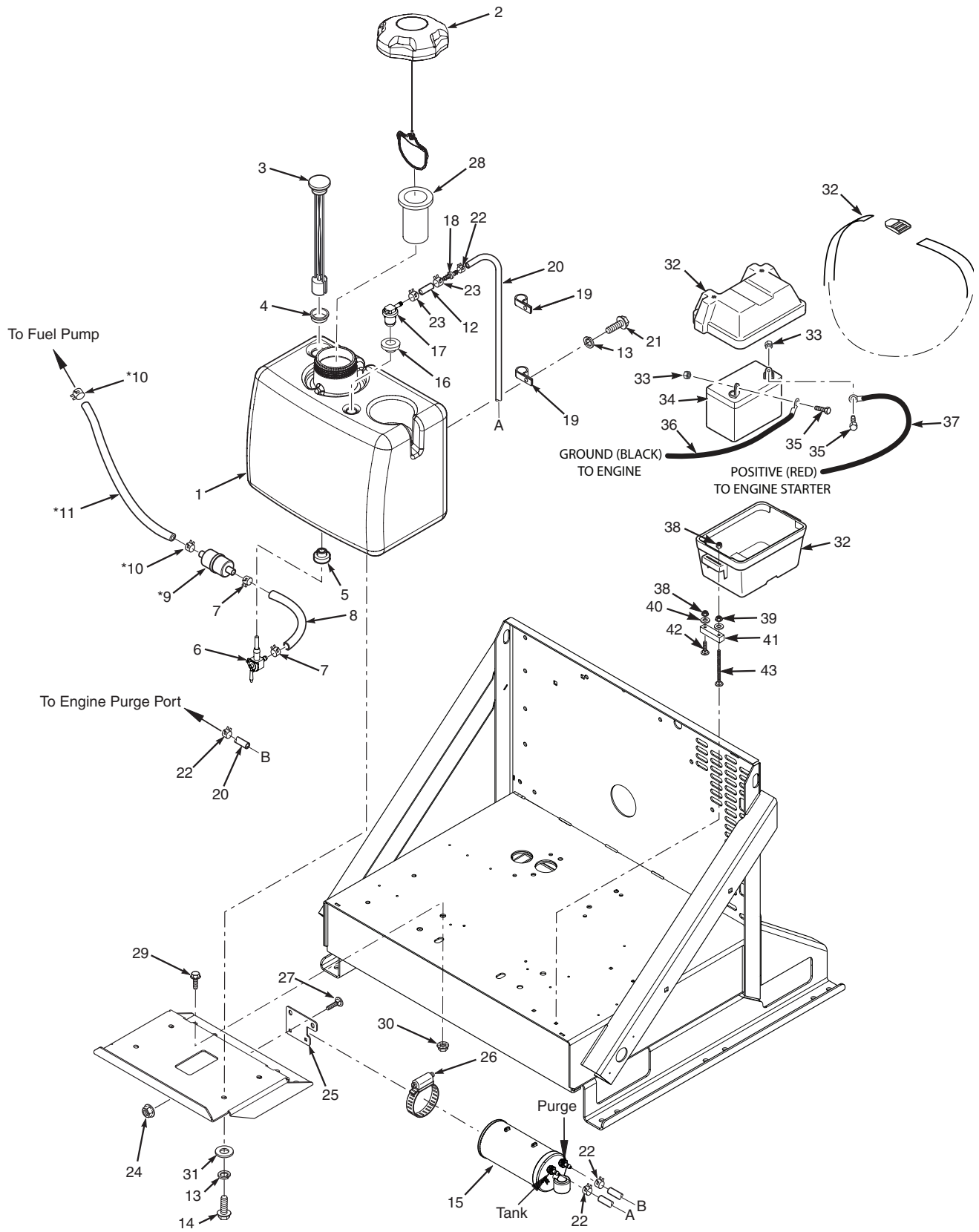

Section 6

FUEL SYSTEM AND BATTERY COMPONENTS

Ref. No.	Part No.	Description
1	462611	Fuel Tank, TL20W
2	484286	Fuel Cap, Tethered
3	484259	Fuel Gauge Assembly, 11 (incl. #4)
4	484242	Seal, Fuel Gauge
5	482571	Bushing, 0.56 Dia. Viton
6	483747	Fuel Shutoff Valve w / Screen
7	48059-01	Clamp, Fuel Hose 1/4" I.D.
8	483617	Hose, Fuel Line 1/4" (order by inch)
9	*	Fuel Filter (contact engine manufacturer)
10	*	Clamp (contact engine manufacturer)
11	*	Fuel Hose (contact engine manufacturer)
12	484347	Hose, Vapor Recovery 1/4" (order by the inch)
13	04030-03	Lockwasher, 5/16"
14	04001-08	Bolt, Hex Head 5/16-18 x 3/4"
15	484287	Carbon Canister, 400cc
16	484285	Grommet, Viton
17	484333	Remote Vent
18	484343-01	Mender, 1/4 x 3/16 w / 0.02 Hole
19	48030-22	Clamp, 3/8"
20	484345	Hose, Vapor Recovery 3/16" (order by inch)
21	04001-08	Bolt, Hex Head 5/16-18 x 3/4"
22	48059--05	Clamp, Vapor Recovery 3/16"
23	48059-02	Clamp, Fuel Hose 7/32" O.D.
24	04019-03	Nut, Serrated Flange 5/16-18
25	426326	Bracket, Canister Mount
26	48136-17	Clamp
27	04003-04	Bolt, Carriage 5/16-18 x 1"
28	484279-01	Tube, Fuel Tank Insert
29	04001-70	Bolt, Hex Head 1/2-13 x 1-1/4"
30	04019-06	Nut, Serrated Flange 1/2-13
31	04040-15	Flatwasher, 5/16-.375 x .875 x .083
32	484990	Battery Box w/Strap
33	04020-02	Nut, 1/4-20
34	*	Battery (not available through Scag Giant-Vac)
35	04001-06	Bolt, Hex Head 1/4-20 x 0.63
36	48029-11	Battery Cable, Black 27"
37	48029-13	Battery Cable, Red 25"
38	04021-08	Nut, Elastic Stop 1/4-20
39	04019-02	Nut, Serrated Flange 1/4-20
40	04040-14	Flatwasher, 1/4-.312 x .750 x .065
41	485053	Spacer, Battery Box
42	04003-09	Bolt, Carriage 1/4-20 x 1-1/4"
43	04003-39	Bolt, Carriage 1/4-20 x 6"

TL20W - TRUCK LOADER DECALS

SCAG *GIANT-VAC*®

485114

SCAG *GIANT-VAC*®

485115

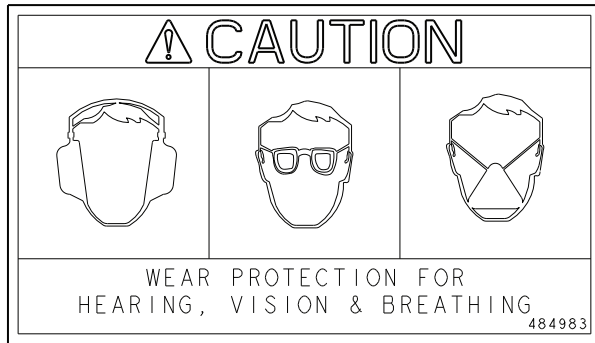

484983



485139

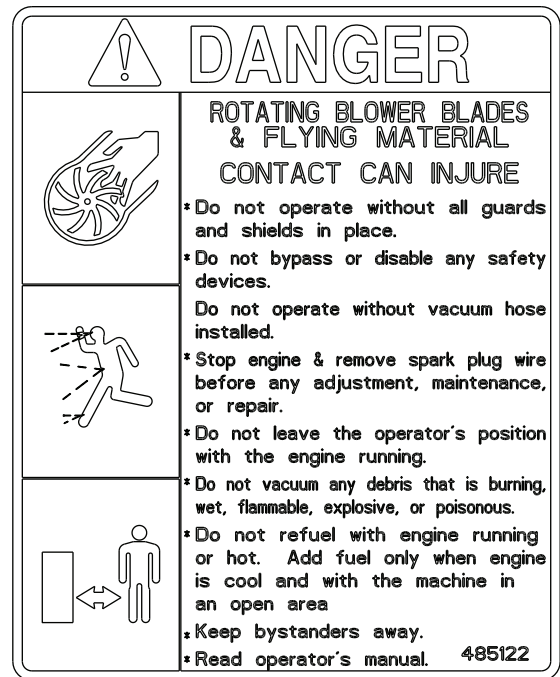

485122

LIMITED WARRANTY - TRUCK LOADERS

Any part of the Truck Loader manufactured by Scag Giant-Vac and found, in the reasonable judgment of Scag Giant-Vac, to be defective in materials or workmanship, will be repaired or replaced by an Authorized Scag Giant-Vac Service Dealer without charge for parts and labor during the periods specified below. This warranty is limited to the original purchaser and is not transferable. Proof of purchase will be required by the dealer to substantiate any warranty claims. All warranty work must be performed by an Authorized Scag Giant-Vac Service Dealer.

This warranty is limited to the following specified periods from the date of the original retail purchase for defects in materials or workmanship:

- Wear items including impellers, wear liners, nose cones, hoses, bearings and tires are not included in this warranty.
- Frame, blower housing and structural components are warranted for two (2) year (parts and labor) for commercial and non-commercial use.
- Engines and electric starters are covered by the engine manufacturer's warranty period. Therefore, there are no warranties made, expressed or implied, for engines by Scag Giant-Vac.
- Batteries are covered for ninety (90) days.
- Any Scag Giant-Vac product used for rental purposes is covered by a 90 day warranty.

The Scag Giant-Vac Truck Loader, including any defective part must be returned to an Authorized Scag Giant-Vac Service Dealer within the warranty period. The expense of delivering the truck loader to the dealer for warranty work and the expense of returning it to the owner after repair will be paid for by the owner. Scag Giant-Vac's responsibility is limited to making the required repairs and no claim of breach of warranty shall be cause for cancellation or rescission of the contract of sale of any Scag Giant-Vac product. "Non-Commercial" use is defined as a single property owner, where the single property is the residence of the owner of the Scag Giant-Vac product. If the truck loader is used on more than the owners single property, it is deemed commercial use and the "non-commercial" warranty does not apply. Scag Giant-Vac reserves the right to deny and / or void the non-commercial warranty if it believes it to be in commercial use.

This warranty does not cover any product that has been subject to misuse, neglect, negligence, or accident, or that has been operated in any way contrary to the operating instructions as specified in the Operator's Manual. The warranty does not apply to any damage to any truck loader that is the result of improper maintenance, or to any truck loader or parts that have not been assembled or installed as specified in the Operator's Manual and Assembly Manual. The warranty does not cover any truck loader that has been altered or modified, changing performance or durability. In addition, the warranty does not extend to repairs made necessary by normal wear, to items subject to abrasion wear, or by the use of parts or accessories which, in the reasonable judgment of Scag Giant-Vac, are either incompatible with the Scag Giant-Vac Truck Loader or adversely affect its operation, performance or durability.

Scag Giant-Vac reserves the right to change or improve the design of any product without assuming any obligation to modify any product previously manufactured. All other implied warranties for truck loader are limited in duration to the two (2) year warranty for commercial and non-commercial use or ninety (90) days used for rental purpose. Accordingly, any such implied warranties including merchantability, fitness for a particular purpose, or otherwise, are disclaimed in their entirety after the expiration of the appropriate warranty period. Scag Giant-Vac's obligation under this warranty is strictly and exclusively limited to the repair or replacement of defective parts and Scag Giant-Vac does not assume or authorize anyone to assume for them any other obligation. Some states do not allow limitations on how long an implied warranty lasts, so the above limitation may not apply to you.

Scag Giant-Vac assumes no responsibility for incidental, consequential or other damages including, but not limited to, expense for gasoline, expense of delivering the truck loader to an Authorized Scag Giant-Vac Service Dealer and expense of returning it to the owner, mechanic's travel time, telephone or telegram charges, rental of a like product during the time warranty repairs are being performed, travel, loss or damage to personal property, loss of revenue, loss of use of the truck loader, loss of time or inconvenience. Some states do not allow the exclusion or limitation of incidental or consequential damages, so the above limitation or exclusion may not apply to you. This warranty gives you specific legal rights, and you may also have other rights which vary from state to state.