

# SCAG<sup>®</sup>

## POWER EQUIPMENT

# *OPERATOR'S MANUAL*



**FREEDOM Z**  
USA SCAG<sup>®</sup>

**Models: SFZ48H-24KT  
SFZ52H-26KT**

Congratulations on owning a Scag mower! This manual contains the operating instructions and safety information for your Scag mower. Reading this manual can provide you with assistance in maintenance and adjustment procedures to keep your mower performing to maximum efficiency. The specific models that this book covers are listed on the inside cover. Before operating your machine, please read all the information enclosed.



# WARNING

## **FAILURE TO FOLLOW SAFE OPERATING PRACTICES MAY RESULT IN SERIOUS INJURY OR DEATH.**

- Read this manual completely as well as other manuals that came with your mower.
- DO NOT operate on steep slopes. To check a slope, attempt to back up it (with the cutter deck down). If the machine can back up the slope without the wheels slipping, reduce speed and use extreme caution.
- Under no circumstances should the machine be operated on slopes greater than 15 degrees. ALWAYS FOLLOW OSHA APPROVED OPERATION.
- Stay two cut widths away from slopes, drop offs, ditches and retaining walls.
- DO NOT mow on wet grass. Wet grass reduces traction and steering control.
- Keep all shields in place, especially the grass discharge chute.
- Before performing any maintenance or service, stop the machine and remove the spark plug wire and ignition key.
- If a mechanism becomes clogged, stop the engine before cleaning.
- Keep hands, feet and clothing away from power-driven parts.
- Keep others off the mower (only one person at a time).

## **REMEMBER - YOUR MOWER IS ONLY AS SAFE AS THE OPERATOR!**

**HAZARD CONTROL AND ACCIDENT PREVENTION ARE DEPENDENT UPON THE AWARENESS, CONCERN, PRUDENCE, AND PROPER TRAINING OF THE PERSONNEL INVOLVED IN THE OPERATION, TRANSPORT, MAINTENANCE, AND STORAGE OF THE EQUIPMENT.**

**This manual covers the operating instructions and illustrated parts list for:**

**SFZ48H-24KT**

**with a serial number of**

**R7600001 to R7699999**

**SFZ52H-26KT**

**with a serial number of**

**R7700001 to R7799999**

**Always use the entire serial number listed on the serial number tag when referring to this product.**

**Table of Contents**

<b>SECTION 1 - GENERAL INFORMATION.....</b>	<b>1</b>
1.1 INTRODUCTION.....	1
1.2 DIRECTION REFERENCE .....	1
1.3 SERVICING THE ENGINE AND DRIVE TRAIN COMPONENTS.....	1
1.4 SYMBOLS .....	2
<b>SECTION 2 - SAFETY INFORMATION .....</b>	<b>3</b>
2.1 INTRODUCTION.....	3
2.2 SIGNAL WORDS .....	3
2.3 BEFORE OPERATION CONSIDERATIONS.....	3
2.4 TESTING THE SAFETY INTERLOCK SYSTEM .....	4
2.5 OPERATION CONSIDERATIONS.....	5
2.6 ROLL-OVER PROTECTION SYSTEM .....	6
2.7 MAINTENANCE CONSIDERATIONS & STORAGE .....	8
2.8 USING A SPARK ARRESTOR.....	8
2.9 SPARK IGNITION SYSTEM .....	8
2.10 SAFETY AND INSTRUCTIONAL DECALS .....	9
<b>SECTION 3 - SPECIFICATIONS .....</b>	<b>10</b>
3.1 ENGINE .....	10
3.2 ELECTRICAL .....	10
3.3 MOWER.....	10
3.4 CUTTER DECK .....	11
3.5 HYDRAULIC SYSTEM .....	11
3.6 WEIGHTS AND DIMENSIONS.....	11
3.7 PRODUCTIVITY .....	11
<b>SECTION 4 - OPERATING INSTRUCTIONS .....</b>	<b>12</b>
4.1 CONTROLS AND INSTRUMENT IDENTIFICATION .....	12
4.2 SAFETY INTERLOCK SYSTEM .....	13
4.3 TESTING THE SAFETY INTERLOCK SYSTEM.....	13
4.4 INITIAL RUN-IN PROCEDURES.....	14
4.5 STARTING THE ENGINE .....	14
4.6 GROUND TRAVEL AND STEERING .....	15
4.7 ENGAGING THE DECK DRIVE (CUTTER BLADES).....	16
4.8 HILLSIDE OPERATION.....	16
4.9 PARKING THE MOWER.....	17
4.10 AFTER OPERATION .....	17
4.11 REMOVING CLOGGED MATERIAL .....	17
4.12 MOVING MOWER WITH ENGINE STOPPED .....	17
4.13 RECOMMENDATIONS FOR MOWING .....	17
4.14 ADJUSTING CUTTING HEIGHT.....	18
4.15 TOWING (OPTIONAL HITCH ACCESSORY).....	18

<b>SECTION 5 - TROUBLESHOOTING CUTTING CONDITIONS .....</b>	<b>19</b>
<b>SECTION 6 - ADJUSTMENTS .....</b>	<b>22</b>
6.1 PARKING BRAKE ADJUSTMENT .....	22
6.2 TRAVEL ADJUSTMENTS .....	23
6.3 THROTTLE CONTROL AND CHOKE ADJUSTMENTS .....	24
6.4 BELT ADJUSTMENT .....	24
6.5 BELT ALIGNMENT.....	24
6.6 CUTTER DECK ADJUSTMENTS .....	25
6.7 ELECTRIC CLUTCH ADJUSTMENT.....	27
<b>SECTION 7 - MAINTENANCE.....</b>	<b>28</b>
7.1 MAINTENANCE CHART - RECOMMENDED SERVICE INTERVALS .....	28
7.2 HYDRAULIC SYSTEM .....	29
7.3 ENGINE OIL .....	30
7.4 ENGINE FUEL SYSTEM .....	31
7.5 ENGINE AIR CLEANER.....	32
7.6 BATTERY.....	33
7.7 DRIVE BELTS.....	34
7.8 CUTTER BLADES.....	34
7.9 TIRES.....	35
7.10 BODY, DECK, AND UPHOLSTERY .....	35
<b>SECTION 8 - ILLUSTRATED PARTS LIST .....</b>	<b>36</b>
8.1 SCAG APPROVED ATTACHMENTS AND ACCESSORIES.....	36
NOTES.....	37
48H & 52H CUTTER DECKS .....	38
CUTTER DECK CONTROLS - SFZ48H / 52H .....	40
SHEET METAL COMPONENTS .....	42
SFZ ROLL-OVER PROTECTION SYSTEM .....	44
DRIVE SYSTEM COMPONENTS - SFZ48H / 52H .....	46
EXHAUST AND ELECTRICAL SYSTEM - SFZ48H / 52H.....	48
FUEL SYSTEM - SFZ48H / 52H.....	50
FREEDOM TRANSAXLE .....	52
REPLACEMENT DECALS AND INFORMATION PLATES .....	54
ELECTRICAL SCHEMATIC .....	56
LIMITED WARRANTY - SFZ .....	INSIDE BACK COVER

## GENERAL INFORMATION

### 1.1 INTRODUCTION

Your mower was built to the highest standards in the industry. However, the prolonged life and maximum efficiency of your mower depends on you following the operating, maintenance and adjustment instructions in this manual.

If additional information or service is needed, contact your Scag Power Equipment Dealer.

We encourage you to contact your dealer for repairs. All Scag dealers are informed of the latest methods to service this equipment and provide prompt and efficient service in the field or at their service shop. They carry a full line of Scag service parts.

**THE REPLACEMENT OF ANY PART ON THIS PRODUCT BY OTHER THAN THE MANUFACTURER'S AUTHORIZED REPLACEMENT PART MAY ADVERSELY AFFECT THE PERFORMANCE, DURABILITY OR SAFETY OF THIS PRODUCT.**

**USE OF OTHER THAN ORIGINAL SCAG REPLACEMENT PARTS WILL VOID THE WARRANTY.**

When ordering parts, always give the model and serial number of your mower. The serial number plate is located where shown in Figure 1-1.

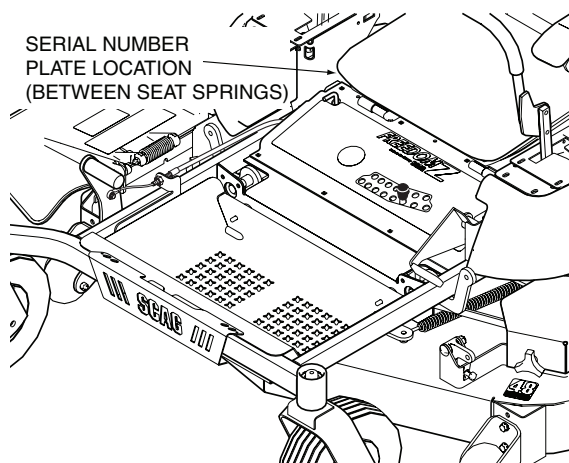

**Figure 1-1. Mower Serial Number Plate Location**

**USE ONLY SCAG APPROVED ATTACHMENTS AND ACCESSORIES.**

Attachments and accessories manufactured by companies other than Scag Power Equipment are not approved for use on this machine. See Section 8, Paragraph 8-1.

### **WARNING**

**For pictorial clarity, some illustrations and figures in this manual may show shields, guards or plates open or removed. Under no circumstances should your mower be operated without these devices in place.**

All information is based upon product information available at the time of approval for printing. Scag Power Equipment reserves the right to make changes at any time without notice and without incurring any obligation.

















### 1.2 DIRECTION REFERENCE

The "Right" and "Left", "Front" and "Rear" of the machine are referenced from the operator's right and left when seated in the normal operating position and facing the forward travel direction.

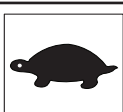
### 1.3 SERVICING THE ENGINE AND DRIVE TRAIN COMPONENTS

The detail servicing and repair of the engine, hydraulic pumps and gearboxes are not covered in this manual; only routine maintenance and general service instructions are provided. For service of these components during the limited warranty period, it is important to contact your Scag dealer or find a local authorized servicing agent of the component manufacturer. Any unauthorized work done on these components during the warranty period may void your warranty.

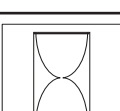
### 1.4 SYMBOLS

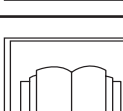
SYMBOL	DESCRIPTION	SYMBOL	DESCRIPTION
	Choke		Transmission
	Parking Brake		Spinning Blade
	On/Start		Spring Tension on Idler
	Off/Stop		Oil
	Falling Hazard		Thrown Object Hazard
	Fast		Slow
	Continuously Variable - Linear		Cutting Element - Basic Symbol
	Pinch Point		Cutting Element - Engage
	Hour meter/Elapsed Operating Hours		Cutting Element - Disengage
	Keep Bystanders Away		Read Operator's Manual

## SAFETY INFORMATION

### 2.1 INTRODUCTION

Your mower is only as safe as the operator. Carelessness or operator error may result in serious bodily injury or death. Hazard control and accident prevention are dependent upon the awareness, concern, prudence, and proper training of the personnel involved in the operation, transport, maintenance and storage of the equipment. Make sure every operator is properly trained and thoroughly familiar with all of the controls before operating the mower. The owner/user can prevent and is responsible for accidents or injuries occurring to themselves, other people or property.

**READ THIS OPERATOR'S MANUAL AND WATCH THE TIPS FOR SAFE OPERATION OF YOUR SCAG ZERO-TURN MOWER VIDEO BEFORE ATTEMPTING TO START YOUR MOWER.**

A replacement manual is available from your authorized Scag Service Dealer or by contacting Scag Power Equipment, Service Department at P.O. Box 152, Mayville, WI 53050 or contact us via the Internet at [www.scag.com](http://www.scag.com). The manual for this machine can be downloaded by using the model and serial number or use the contact form to make your request. Please indicate the complete model and serial number of your Scag product when requesting replacement manuals.

### 2.2 SIGNAL WORDS



This symbol means **“Attention! Become Alert! Your Safety is Involved!”** The symbol is used with the following signal words to attract your attention to safety messages found on the decals on the machine and throughout this manual. The message that follows the symbol contains important information about safety. To avoid injury and possible death, carefully read the message! Be sure to fully understand the causes of possible injury or death.

#### SIGNAL WORD:

It is a distinctive word found on the safety decals on the machine and throughout this manual that alerts the viewer to the existence and relative degree of the hazard.

The signal word “DANGER” denotes that an extremely hazardous situation exists on or near the machine that could result in high probability of death or irreparable injury if proper precautions are not taken.

The signal word “WARNING” denotes that a hazard exists on or near the machine that can result in injury or death if proper precautions are not taken.

The signal word “CAUTION” is a reminder of safety practices on or near the machine that could result in personal injury if proper precautions are not taken.

Your safety and the safety of others depends significantly upon your knowledge and understanding of all correct operating practices and procedures of this machine.

### 2.3 BEFORE OPERATION CONSIDERATIONS

**Check all hydraulic connections for tightness. Inspect all hydraulic hoses and / or lines to insure they are in good condition before operating.**

1. NEVER allow children to operate this riding mower. Do not allow adults to operate this machine without proper instructions.
2. Do not mow when children and/or others are present. Keep children out of the mowing area and in the watchful care of a responsible adult other than the operator. Be alert and turn machine off if a child enters the area.

3. DO NOT allow children to ride or play on the machine, it is not a toy.
4. Clear the area to be mowed of objects that could be picked up and thrown by the cutter blades.
5. DO NOT carry passengers.
6. DO NOT operate the machine under the influence of alcohol or drugs.
7. If the operator(s) or mechanic(s) cannot read English, it is the owner's responsibility to explain this material to them.
8. DO NOT wear loose fitting clothing. Loose clothing, jewelry or long hair could get tangled in moving parts. Do not operate the machine wearing shorts; always wear adequate protective clothing including long pants. Wearing safety glasses, safety shoes and a helmet is advisable and is required by some local ordinances and insurance regulations.

### **WARNING**

**Always wear hearing protection. Operating this machine over prolonged periods of time can cause loss of hearing.**

9. Keep the machine and attachments in good operating condition. Keep all shields and safety devices in place. If a shield, safety device or decal is defective or damaged, repair or replace it before operating the machine.
10. Fuel is flammable; handle it with care. Fill the fuel tank outdoors. Never fill it indoors. Use a funnel or spout to prevent spillage. Clean up any spillage before starting the engine.
11. DO NOT add fuel to a running or hot engine. Allow the engine to cool for several minutes before adding fuel. Never fuel indoors or inside enclosed trailers.
12. Keep flammable objects (cigarettes, matches, etc.), open flames and sparks away from the fuel tank and fuel container. Use only approved containers.
13. See Section 7.4 ENGINE FUEL SYSTEM for fueling procedure.
14. Equipment must comply with the latest requirements per SAE J137 and/or ANSI/ASAE S279 when driven on public roads.

### - NOTE -

*If the mower is driven on public roads, it must comply with state and local ordinances as well as SAE J137 and/or ANSI / ASAE S279 requirements. Contact your local authorities for regulations and equipment requirements.*

15. Do not operate without the side discharge chute installed and in the down position or with an optional grass catcher or mulch plate completely installed.
16. Check the blade mounting bolts at frequent intervals for proper tightness.
17. Make sure all hydraulic fluid connections are tight and all hydraulic hoses and lines are in good condition before starting the machine.

### **WARNING**

**This machine is equipped with an interlock system intended to protect the operator and others from injury. This is accomplished by preventing the engine from starting unless the deck drive is disengaged, the steering control levers are in the neutral position and the operator is in the seat. The system shuts off the engine if the operator leaves the seat with the deck drive engaged and/ or the steering control levers are not in the neutral position and the parking brake is not engaged. Never operate equipment with the interlock system disconnected or malfunctioning.**

18. Be sure the interlock switches are functioning correctly.

## 2.4 TESTING THE SAFETY INTERLOCK SYSTEM

The safety interlock system should be tested each time before using the machine. If the safety interlock system does not operate as described below, contact your local Authorized Scag Power Equipment Dealer immediately to have the safety interlock system repaired.

1. Sit in the seat in the operating position, engage the parking brake, place the steering control levers in the neutral lock position, and engage the PTO switch to the ON (up) position. Try to start the engine; the engine should not start



## Section 2

2. Sit in the seat in the operating position, engage the parking brake, move the PTO switch to the OFF (down) position, move either of the steering control handles out of the neutral lock position. Try to start the engine; the engine should not start. Repeat for the other steering control lever.

**-NOTE-**

*All SFZ models will start with the parking brake engaged or disengaged. For all test procedures listed below, the engine should be started with the parking brake engaged unless specified otherwise.*

3. Sit in the seat in the operating position, engage the parking brake, place the steering control levers in the neutral lock position, move the PTO switch to the OFF (down) position, and start the engine. With the engine running, release the parking brake and rise slightly off of the seat. The engine should shut off.
4. Sit in the seat in the operating position, engage the parking brake, place the steering control levers in the neutral lock position, move the PTO switch to the OFF (down) position, and start the engine. With the engine running, engage the PTO switch to the ON (up) position, and rise slightly off of the seat. The engine should shut off.
5. Sit in the seat in the operating position, engage the parking brake, place the steering control levers in the neutral lock position, move the PTO switch to the OFF (down) position, and start the engine. With the engine running, move either steering control lever out of the neutral lock position. The engine should shut off. Repeat for the other steering control lever.
2. Reduce speed and exercise extreme caution on slopes and in sharp turns to prevent tipping or loss of control. Be especially cautious when changing directions on slopes.
3. Stay two cut widths away from slopes, drop offs, ditches and retaining walls.
4. To prevent tipping or loss of control, start and stop smoothly, avoid unnecessary turns and travel at reduced speed. Use caution when operating the mower on an incline with the optional grass catcher installed.
5. Immediately apply the parking brake if you lose steering control while operating. Inspect the machine and correct the problem before continuing to operate.
6. When using any attachment, never direct the discharge of material toward bystanders or allow anyone near the machine while in operation.
7. Before attempting to start the engine, with the operator in the seat, disengage power to the cutter deck, place the steering control levers in the neutral position and engage the parking brake.
8. If the mower discharge ever plugs, shut off the engine, remove the ignition key, and wait for all movement to stop before removing the obstruction.

### 2.5 OPERATION CONSIDERATIONS

1. Know the function of all controls and how to stop quickly.

## WARNING

**DO NOT operate on steep slopes. To check a slope, attempt to back up it (with the cutter deck down). If the machine can back up the slope without the wheels slipping, reduce speed and use extreme caution. Under no circumstances should the machine be operated on slopes greater than 15 degrees. See Figure 2-2, Page 7 to determine approximate slope of area to be mowed. ALWAYS FOLLOW OSHA APPROVED OPERATION.**

## WARNING

**DO NOT use your hand to dislodge the clogged discharge chute. Use a stick or other device to remove clogged material after the engine has stopped running and the blades have stopped turning.**

9. Be alert for holes, rocks, roots and other hidden hazards in the terrain. Keep away from any drop-offs. Beware of overhead obstructions (low limbs, etc.) and underground obstacles (sprinklers, pipes, tree roots, etc.). Cautiously enter a new area. Be alert for hidden hazards.
10. Disengage power to cutter deck before backing up. Do not mow in reverse unless absolutely necessary and then only after observation of the entire area behind the mower. If you must mow in reverse, maintain a constant lookout to the rear of the machine and mow slowly.
11. DO NOT turn sharply. Use care when backing up.

12. Disengage power to cutter deck before crossing roads, walks or gravel drives.
13. Mow only in daylight or good artificial light.
14. NEVER raise the deck with the blades engaged.
15. Take all possible precautions when leaving the machine unattended, such as disengaging the mower, lowering the attachments, setting the parking brake, stopping the engine, and removing the key.
16. Disengage power to the attachments when transporting or when not in use.
17. The machine and attachments should be stopped and inspected for damage after striking a foreign object, and damage should be repaired before restarting and operating the machine.

### CAUTION

**Do not touch the engine or the muffler while the engine is running or immediately after stopping. These areas may be hot enough to cause a burn.**

### DANGER

**DO NOT run the engine inside a building or a confined area without proper ventilation. Exhaust fumes are hazardous and contain carbon monoxide which can cause brain injury and death.**

18. Keep hands and feet away from cutter blades and moving parts. Contact can injure.
19. Transport the mower using a heavy duty trailer or truck. Insure the trailer or truck has all of the necessary lighting and markings as required by laws, codes, and ordinances. Secure a trailer with a safety chain.
20. Be cautious when loading and unloading onto trailers or trucks. Use only a full width ramp. Ramp angle should be no more than 15 degrees. Back up the ramp and drive down forward.
21. When transporting the mower, make sure the park brake is engaged, the steering control levers are in the neutral position, the engine is off with the key removed, and the wheels have been blocked.

22. Tie the mower down securely using straps, chains, cable, or ropes. Both front and rear straps must be directed down and outward from machine.
23. Use care when approaching blind corners, shrubs, trees, or other objects that may obscure vision.
24. NEVER leave the machine running unattended.

## 2.6 ROLL-OVER PROTECTION SYSTEM

### WARNING

**The seat belt must be securely fastened during operation. Failure to do so could cause serious injury or loss of life.**

This mower has been designed for good traction and stability under normal mowing conditions. However, caution must be used when traveling on slopes, especially when the grass is wet. Do not mow on wet grass. Wet grass reduces traction and steering control.

Any or all parts of the Roll-Over Protection System MUST NOT be removed. Failure to adhere to this guideline could result in injury or death.

The potential exposure of the seat belt to severe environmental conditions make it crucial to inspect the seat belt system regularly.

It is recommended that the seat belt be inspected on a daily basis for signs of damage. Any seat belt system that shows cuts, fraying, extreme or unusual wear, significant discoloration due to UV exposure, dirt or stiffness, abrasion to the seat belt webbing, or damage to the buckle, latch plate, hardware or any other obvious problem should be replaced immediately.

### WARNING

**Failure to properly inspect and maintain the seat belt can cause serious injury or loss of life.**

1. Check the full length of the seat belt webbing for cuts, wear, fraying, dirt and stiffness. See Figure 2-1.

## Section 2

2. Check the seat belt webbing in areas exposed to ultra violet rays from the sun or extreme dust or dirt. If the original color of the webbing in these areas is extremely faded and/or is packed with dirt, the physical strength of this webbing may have deteriorated. If this condition exists, replace the seat belt system.
3. Check the buckle and latch for proper operation and determine if the latch plate is excessively worn, deformed, or if the buckle is damaged or cracked. See Figure 2-1.

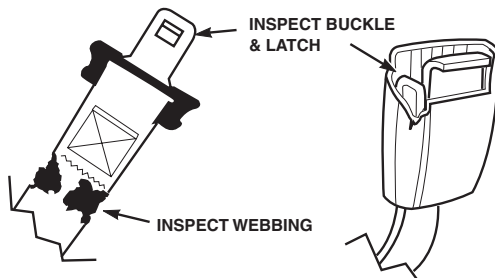

**Figure 2-1. Seat Belt Inspection**

## **WARNING**

**Reduce speed when turning, operating on slopes, slick or wet surfaces. Allow extra distance to stop.**

**Stay off of slopes too steep for safe operation. To check a slope, attempt to back up it (with the cutter deck down). If the machine can not back up the slope without the wheels slipping, do not operate the machine on this slope. Under no circumstances should the machine be operated on slopes greater than 15 degrees. See Figure 2-2 to determine approximate slope.**

**DO NOT mow near drop-offs, ditches or embankments. The machine could suddenly roll over if a wheel goes over the edge or if the edge caves in.**

**Operate the machine smoothly, no sudden turns, starts or stops on a slope.**

**NEVER tow on slopes. The weight of the towed equipment may cause loss of traction and loss of control.**

**DO NOT permit untrained personnel to operate the machine.**

**Be cautious when loading and unloading onto trailers or trucks.**

**Use only a full width ramp.**

**Ramp angle should be no more than 15 Degrees. See Figure 2-2 to help determine approximate slope.**

**Back up the ramp and drive down forward.**

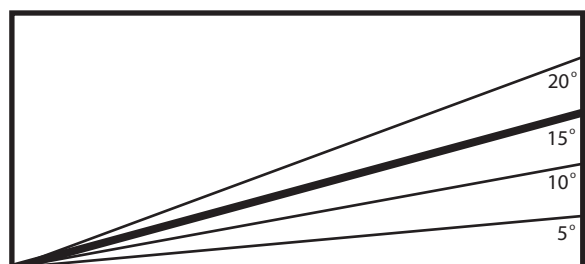

**Figure 2-2. Slope Angle Graph**

### 2.7 MAINTENANCE CONSIDERATIONS & STORAGE

1. Never make adjustments to the machine with the engine running unless specifically instructed to do so. If the engine is running, keep hands, feet, and clothing away from moving parts.
2. Disengage drives, lower implement, set parking brake, stop engine and remove key or disconnect spark plug wire to prevent accidental starting of the engine when servicing or adjusting the machine. Wait for all movement to stop before adjusting, cleaning or repairing.
3. Disconnect battery or remove spark plug wire before making any repairs. Disconnect the negative terminal first and the positive last. Reconnect the positive first and the negative last.
4. Keep all nuts, bolts and screws tight, to ensure the machine is in safe working condition. Check blade mounting bolts frequently to be sure they are tight.
5. Do not change the engine governor settings or overspeed the engine. See the engine operator's manual for information on engine settings.
6. To reduce fire hazard, keep the cutting units, drives, muffler and engine free of grass, leaves, excessive grease, oil and dirt.
7. Park the machine on level ground and engage the parking brake.
8. NEVER allow untrained personnel to service the machine.
9. Use care when checking blades. Use a Blade Buddy, wrap the blade(s) or wear gloves and USE CAUTION when servicing blades. Only replace blades. NEVER straighten or weld blades.
10. Keep all parts in good working condition. Replace all worn or damaged decals.
11. Use jack stands to support components when required.
12. Carefully release pressure from components with stored energy.

### WARNING

**Hydraulic fluid is under high pressure and can penetrate skin causing injury. If hydraulic fluid is injected into the skin, it must be surgically removed within a few hours by a doctor or gangrene may result.**

**Keep body and hands away from pinholes or nozzles that eject hydraulic fluid under high pressure. Use paper or cardboard and not hands to search for leaks.**

**Safely relieve all pressure from the hydraulic system by placing the control levers in the neutral lock position and shutting off the engine before performing any work on the hydraulic system.**

**If you need service on your hydraulic system, please see your authorized Scag dealer.**

13. Let the engine cool before storing.
14. DO NOT store the machine near an open flame.
15. Shut off fuel while storing or transporting.
16. DO NOT store fuel near flames or drain indoors.
17. Charge batteries in an open, well ventilated area, away from spark and flames. Unplug charger before connecting or disconnecting from battery. Wear protective clothing and use insulated tools.

### 2.8 USING A SPARK ARRESTOR

The engine in this machine is not equipped with a spark arrestor muffler. It is in violation of California Public Resource Code Section 4442 to use or operate this engine on or near any forest covered, brush covered or grass covered land unless the exhaust system is equipped with a spark arrestor meeting any applicable local or state laws. Other states or federal areas may have similar laws. Check with your state or local authorities for regulations pertaining to these requirements.

### 2.9 SPARK IGNITION SYSTEM

This spark ignition system complies with Canadian ICES-002.

## Section 2

### 2.10 SAFETY AND INSTRUCTIONAL DECALS

**DANGER**

**SPINNING BLADES**  
**KEEP CLEAR**

**BLADE CONTACT & THROWN OBJECTS CAN INJURE**

483505

**WARNING**

DO NOT OPERATE WITHOUT DISCHARGE CHUTE, MULCHING KIT, OR ENTIRE GRASS CATCHER INSTALLED 483405

483405

**WARNING**

**ROTATING BLADES AND BELTS**

- \* Keep hands, feet & clothing clear
- \* Keep all guards in place
- \* Shut off engine & disengage blade clutch before servicing
- \* Use caution in directing discharge
- \* Read instruction manual before operating

**DO NOT OPERATE UNLESS GRASS CATCHER, MULCHING KIT OR DISCHARGE CHUTE IS INSTALLED**

483406

**WARNING**

**INSTALL BELT COVER BEFORE OPERATING MACHINE**  
READ OPERATOR'S MANUAL

483402

**FORWARD**

**F**

**R**

**REVERSE**

481568

**WARNING**

Replace seat only with Scag approved seat with seat mounting provisions and Scag approved seat belts. Failure to follow these directions could result in injury or death in the event of a rollover.

483633

**WARNING**

**SERIOUS INJURY OR DEATH MAY RESULT FROM MACHINE ROLLOVER**

Failure to follow these instructions could result in serious injury or death.

- Do not operate machine on steep slopes or near drop offs.
- Avoid sharp and/or quick turns.
- Do not exceed the machine weight rating on the ROPS.
- Always use the seat belt.
- Do not jump if machine tips while ROPS is fully extended and using seat belt.
- Do not limp if machine tips while ROPS is fully extended and using seat belt.
- If ROPS is foldable: Keep ROPS fully extended whenever possible.

**WHEN ROPS MUST BE DOWN:**  
Do not use the seat belt.  
Drive with extra care.

483300

**IMPORTANT**

Operation on slopes can be hazardous.

This machine was originally equipped with a Rollover Protection Device with a Roll Bar and Seat Belt.

See your dealer if either is missing or damaged. 483425

483425

**DANGER**

Avoid injury from burns

- Shut off engine
- Allow to cool several minutes
- Remove cap slowly
- Do not overfill

Molded in Fuel Tank

**IMPORTANT ADJUSTMENT PROCEDURES**  
READ OPERATORS MANUAL FOR MORE DETAILS

Check tire pressure - Drive tires-8 psi -  
- Caster tires-25 psi

**FREE WHEEL OPERATION**  
To move machine without running engine, pull both dump valve rods up and back (located at rear of machine) and latch. Pull rods forward and latch into front slot to operate mower.

**NEUTRAL ADJUSTMENT**

Control Lever  
Linkage Capscrew

To re-set neutral, have engine off and control levers in neutral. Loosen upper linkage capscrew. Allow transmission to position linkage rod and tighten upper capscrew. Repeat for opposite side. If wheels still creep after adjustment, see an authorized Scag dealer.

**HYDRAULIC FLUID LEVEL**  
Check hydraulic fluid level while fluid is cool. Fluid level should be in sight window. Fill with 20W50 motor oil only.

**IMPORTANT**  
Do not overfill. Room for hot fluid expansion must be allowed or resulting expansion may cause leaks in the system.

**TRACKING ADJUSTMENT**

Control Lever  
Stop Bolt

If machine pulls to right, adjust LH control stop bolt CW (inward) to slow left wheel down. Adjust RH control stop bolt CW (inward) to slow right wheel down.

483632

483632

DECK LATCH RELEASE

**FREEDOM Z™**

USA SCAG

**BIG POWER EQUIPMENT**  
MAYVILLE WEST BEND SEASIDE WISCONSIN  
USA  
DISTRIBUTORS OF MAYVILLE

START/DRIVE PROCEDURE

- Engage parking brake
- Disengage mower deck drive
- Move control levers to neutral position
- Release parking brake
- Shift control levers to select forward or reverse with hydro control levers.

**WARNING**

**AVOID SERIOUS INJURY OR DEATH**  
Read the Operators Manual.  
Notice the attention on equipment on a distributor Scag.  
If machine stops going uphill, stop blades and back down slowly.  
Avoid sudden turns.  
Do not mow when children or others are around.  
Always saddle tires.  
Look down and behind before blades off.  
Always saddle tires.  
Remove objects that could be thrown by the blades.  
Lifted operators only.

485412

**SPECIFICATIONS**

**3.1 ENGINE**

General Type .....Heavy Duty Industrial/Commercial Gasoline  
 Model:  
     Scag Model SFZ48H-24KT ..... Kohler KT735  
     Scag Model SFZ52H-26KT ..... Kohler KT745  
 Displacement:  
     Kohler KT735 / KT745 ..... 725cc  
 Type ..... 4 Cycle Gasoline, Twin Cylinder, Vertical Shaft  
 Cylinders..... 2 with Cast Iron Sleeves  
 Governor.....Mechanical Type with Variable Speed Control Set At 3600 RPM  
 Idle Speed:  
     Kohler ..... 1750 RPM  
 Fuel Pump ..... Integral Fuel Pump with In-Line Fuel Filter  
 Fuel..... Non-Leaded Gasoline with a Minimum Octane Rating of 87  
 Oil Pump..... Positive Displacement Gerotor™  
 Starter:..... Electric Starting with Bendix Shift Starter  
 Belts.....Kevlar cord. Self-adjusting, Self-tightening

**3.2 ELECTRICAL**

Battery ..... 12 Volt  
 Charging System ..... Alternator  
 Charging Output:  
     Kawasaki ..... 12 Volt, 13 Amp  
     Kohler ..... 12 Volt, 12 Amp  
 System Polarity..... Negative Ground  
 Starter..... 12 Volt Electric Ring Gear Type, Key Operated  
 Interlock Switches..... Seat, Neutral Control, Mower Engagement (PTO), Parking Brake  
 Instrument Panel ..... Key Switch, Throttle Lever, Manual Choke, PTO Switch  
 Fuses..... Two (2) 20 Amp

**3.3 MOWER**

Drive System ..... Hydraulic Drive with Two Hydro-Gear™ Integrated Zero-Turn Axles  
     Scag Models (SFZ48H-22KT, SFZ52H-24KT) .....Hydro-Gear™ ZT-2800  
 Steering/Travel Control ..... Twin Lever Fingertip Steering Control  
     with Individual Control to Each Wheel with Gas Spring Dampers  
 Parking Brake ..... Lever Actuated Linkage to Brakes on Both Drive Wheel Axles  
 Wheels:  
     (2) Front Caster ..... 11 X 6 - 5 Two-Ply  
     (2) Drive - ..... 20 X 10-10 Four-Ply Pneumatic Tubeless, Radius Edge  
 Tire Pressure:  
     Front Caster..... 25 PSI  
     Drive ..... 8 PSI  
 Fuel Tank ..... Single 6-1/2 Gallon Seamless Roto-Low Perm. Tank with Large Opening and Fuel Cap  
 Seat ..... Padded, Thick Cushion with Extra Spring Support  
 Travel Speed:  
     Forward ..... 0 up to 8 MPH  
     Reverse ..... 0 up to 5 MPH  
 -NOTE- The machine will travel up to 8 mph for transport purposes. For best cutting performance the forward travel speed should be adjusted depending upon the cutting conditions.

## Section 3

### 3.4 CUTTER DECK

Type .....	Floating, Adjustable, Anti-Scalping, Hybrid Design Combines Out-Front and Belly-Mount Designs	
Construction .....	10-Gauge top with 11-Gauge reinforcement throughout the spindle area, 7-Gauge skirt for strength and longevity	
True Cutting Width:		
48H.....		48" (122.0 cm)
52H.....		52" (132.0 cm)
Cutting Height Adjustment.....	Foot-Operated Lever Adjustment from Operator's Seat, 1.00" to 4.5" in 1/4" increments	
Cutter Blades.....	0.197 in. Thick, Milled Edge, Wear Resistant	
Blade Engagement.....	Electric Blade Engagement Clutch with Control Panel Switch Connected to the Cutter Deck through a Belt	
Discharge Opening.....	Extra Wide Discharge Opening with Spring-Loaded Discharge Chute	
Discharge Chute.....	Black, Polypropylene (Plastic), Flexible	
Spindles.....	Heavy-Duty Spindle Shaft, Cast Aluminum Housing, Sealed Ball Bearing, Maintenance-Free	
Spindle Pulleys.....	Split Steel	
Cutter Deck Belts.....	B-section with Kevlar Cord. Self-Adjusting, Self-Tightening	
Electric Clutch Type .....	Ogura Heavy Duty PTO Clutch Brake	

### 3.5 HYDRAULIC SYSTEM

Hydraulic Oil Filter .....	40 Micron Spin-on Element Type
Hydraulic Expansion Reservoir .....	Nylon

### 3.6 WEIGHTS AND DIMENSIONS

	<b>48H</b>	<b>52H</b>
Length.....	73"	73"
Tracking Width .....	47.5"	47.5"
Overall Width w/chute down .....	60.5"	64.5"
Overall Width w/chute up.....	49"	53"
Overall Height.....	60"	60"
Operating Weight.....	745#	765#

### 3.7 PRODUCTIVITY

	<b>48H</b>	<b>52H</b>
Cutting Width .....	48"	52"
Acres Per Day.....	18.6	20.2

The preceding chart will aid you in determining how many acres your Scag mower will cut per day. The chart is an estimate based on 8 hours per day cutting time at 6 MPH with a 20% allowance for overlap and turns.

### OPERATING INSTRUCTIONS

#### CAUTION

Do not attempt to operate this mower unless you have read this manual. Learn the location and purpose of all controls and instruments before you operate this mower.

#### 4.1 CONTROLS AND INSTRUMENT IDENTIFICATION

Before operating the mower, familiarize yourself with all mower and engine controls. Knowing the location, function and operation of these controls is important for safe and efficient operation of the mower.

- 1. Ignition Switch (Figure 4-1).** The ignition switch is used to start the engine and has three positions; OFF, ON, and START.
- 2. Mower Deck Switch (Figure 4-1).** Used to engage and disengage the mower drive system. Pulling up on the switch will engage the deck drive. Pushing down on the switch will disengage the deck drive.
- 3. Engine Choke Control (Figure 4-1).** Used to start a cold engine.
- 4. Engine Throttle Control (Figure 4-1).** Used to control the engine speed. Pushing the lever forward increases engine speed. Pulling the lever back decreases engine speed. Full back position is the IDLE position. Full forward is the cutting position.

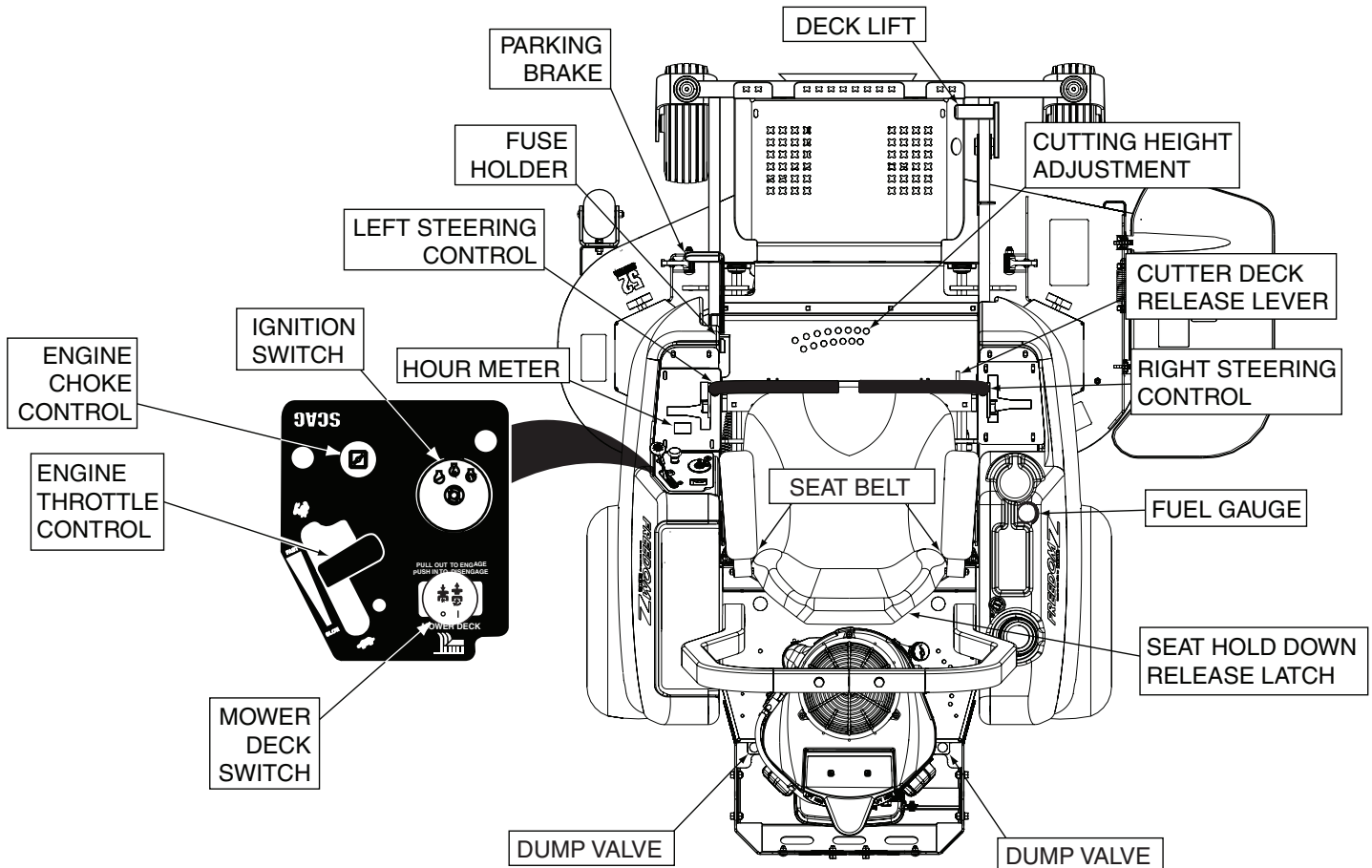
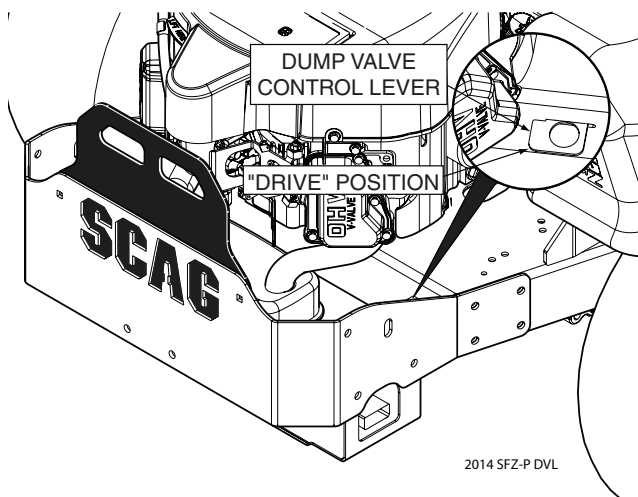

Figure 4-1. Controls and Instruments



## Section 4

5. **Hourmeter (Figure 4-1).** Indicates the number of hours the engine has been operated. It operates whenever the ignition key switch is in the ON position. Has preset maintenance reminders for engine and hydraulic system oil changes. Will start flashing scheduled maintenance 2 hours before preset time and continue flashing until 2 hours after. Automatically resets.
6. **Fuse Holders (Figure 4-1).** Two 20-amp fuses protect the mower's electrical system. To replace fuses, pull fuse out of the socket and install a new fuse.
7. **Left Steering Control (Figure 4-1).** Used to control the mower's left wheel when traveling forward or reverse.
8. **Right Steering Control (Figure 4-1).** Used to control the mower's right wheel when traveling forward or reverse.
9. **Parking Brake Control (Figure 4-1).** Used to engage and disengage the parking brakes. Pull the lever back to engage the parking brakes. Push the lever forward to disengage the parking brakes.
10. **Dump Valve Control Levers (Figure 4-2).** Located on the left and right side at the back of the unit, used to "free-wheel" the mower. Pushing the levers forward (towards the front of the mower) allows the unit to move under hydraulic power. Pulling the levers backward and locking in the notch (towards the rear of the mower) allows the mower to be moved by hand (free-wheeling).



**Figure 4-2. Dump Valve Control**

11. **Deck Lift Foot Lever (Figure 4-1).** Used to raise and lower the cutter deck.
12. **Cutting Height Adjustment (Figure 4-1).** Used to set the cutter deck at the desired cutting height.
13. **Deck Release Lever (Figure 4-1).** Used to lock the cutter deck in the transport position. Push the foot pedal forward and pull back on the release lever to release the cutter deck for normal mowing.
14. **Seat Belt (Figure 4-1).** Used to secure the operator. Seat belt must be worn at all times during operation.
15. **Seat Hold Down Release Latch (Figure 4-1).** Located behind the seat. Used to secure the seat in the operator's position. Release the latch to gain access under the seat.

## 4.2 SAFETY INTERLOCK SYSTEM

The mower is equipped with a safety interlock system that prevents the engine from starting unless the deck drive is disengaged, the steering control levers are in the neutral position and the operator is in the seat. The interlock system shuts off the engine if the operator leaves the seat with the steering control levers not in the neutral position and/or the cutter blades engaged and the parking brake not engaged.

### ⚠ **WARNING**

**Never operate the mower with the interlock system disconnected or malfunctioning. Do not disengage or bypass any switch; injury to yourself and others or property damage could result.**

## 4.3 TESTING THE SAFETY INTERLOCK SYSTEM

The safety interlock system should be tested each time before using the machine. If the safety interlock system does not operate as described below, contact your local Authorized Scag Power Equipment Dealer immediately to have the safety interlock system repaired.

1. Sit in the seat in the operating position, engage the parking brake, place the steering control levers in the neutral lock position, and engage the PTO switch to the ON (up) position. Try to start the engine; the engine should not start

2. Sit in the seat in the operating position, engage the parking brake, move the PTO switch to the OFF (down) position, move either of the steering control handles out of the neutral lock position. Try to start the engine; the engine should not start. Repeat for the other steering control lever.

**-NOTE-**

*All SFZ models will start with the parking brake engaged or disengaged. For all test procedures listed below, the engine should be started with the parking brake engaged unless specified otherwise.*

3. Sit in the seat in the operating position, engage the parking brake, place the steering control levers in the neutral lock position, move the PTO switch to the OFF (down) position, and start the engine. With the engine running, release the parking brake and rise slightly off of the seat. The engine should shut off.
4. Sit in the seat in the operating position, engage the parking brake, place the steering control levers in the neutral lock position, move the PTO switch to the OFF (down) position, and start the engine. With the engine running, engage the PTO switch to the ON (up) position, and rise slightly off of the seat. The engine should shut off.
5. Sit in the seat in the operating position, engage the parking brake, place the steering control levers in the neutral lock position, move the PTO switch to the OFF (down) position, and start the engine. With the engine running, move either steering control lever out of the neutral lock position. The engine should shut off. Repeat for the other steering control lever.

### 4.4 INITIAL RUN-IN PROCEDURES

#### FIRST DAY OF USE OR APPROXIMATELY 20 HOURS

1. Check all belts for proper alignment and wear at 2, 4 and 8 hours.
2. Change the engine oil and oil filter after the first 20 hours of operation. (See Section 7.3.)
3. Check hydraulic oil level in reservoir. (See Section 7.2.)
4. Check for loose hardware. Tighten as needed.
5. Check interlock system for proper operation. (See Section 4.2.)
6. Check tire pressure. Adjust pressure if necessary. (See Section 7.9.)

### 4.5 STARTING THE ENGINE

## CAUTION

**DO NOT USE STARTING FLUIDS. Use of starting fluids in the air intake system may be potentially explosive or cause a “runaway” engine condition that could result in engine damage and/or personal injury.**

1. Be sure the fuel shutoff valve, located behind the operator's seat, is completely open.
2. Sit in the operator's seat, fasten seat belt and place the steering control levers in the neutral position.
3. Engage the parking brake.
4. Place the PTO switch in the disengaged position.
5. If the engine is cold, choke the engine as needed.
6. Move the engine throttle control to about half engine speed.
7. Turn the ignition key to the START position and release the key as soon as the engine starts. Do not hold the key in the START position for more than 15 seconds at a time. Allow at least 60 seconds between each cranking attempt to prevent overheating of the starter motor. Prolonged cranking can damage the starter motor and shorten battery life.
8. Allow engine to warm before operating the mower.

## Section 4

### 4.6 GROUND TRAVEL AND STEERING

**- IMPORTANT -**

If you are not familiar with the operation of a machine with lever steering and/or hydrostatic transmissions, the steering and ground speed operations should be learned and practiced in an open area, away from buildings, fences, or obstructions.

Learn the operation on flat ground before operating on slopes.

Start practicing with a slow engine speed and slow forward travel.

Learn to feather the steering controls to obtain a smooth operating action.

Practice operating the mower until you are comfortable with the controls before proceeding to mow.

#### FORWARD TRAVEL

To travel forward with the mower, disengage the parking brake, pull levers inward out of the neutral lock position and slowly push the steering control levers forward an equal distance. The further the steering control levers are pushed forward the greater the forward speed will be. To increase the speed, push the steering control levers further forward and to decrease the speed, pull the steering control levers back.

To stop the forward travel, pull the steering control levers back to the neutral position.

To steer the mower left while traveling forward, pull the left steering lever back. The further the lever is pulled back, the quicker the mower will turn left.

To steer the mower right while traveling forward, pull the right steering control lever back. The further the lever is pulled back, the quicker the mower will turn right.

**- NOTE -**

Smooth operation of the steering levers will produce smooth mower operation. While learning the operation of the steering controls, keep the travel speed low.

**- IMPORTANT -**

Do not travel forward over a curb. The mower will hang up on the curb. Raise the deck and travel backwards over the curb at a 45 degree angle. (See Figure 4-1 and Section 4-1 item 11 for cutter deck raising description.)

#### REVERSE TRAVEL

 **CAUTION**

Disengage power to the mower before backing up. Do not mow in reverse unless absolutely necessary and then only after observation of the entire area behind the mower.

 **CAUTION**

Before backing up, observe the rear for persons and obstructions. Clear the area before backing up. Possible injury or property damage could occur.

To travel in reverse, pull levers inward out of the neutral lock position and pull both handles back. Keep the travel speed low while traveling in reverse.

**- NOTE -**

The mower may not travel straight in reverse. Slight adjustments may need to be made using the steering controls.

To steer left while traveling in reverse, allow the left steering control lever to move forward. The further the control is allowed to move forward, the quicker the mower will turn left.

To steer right while traveling in reverse, allow the right steering control lever to move forward. The further the control is allowed to move forward, the quicker the mower will turn right.

To stop the reverse travel, allow the steering control levers to return to the neutral position. If the mower is to be parked, place the handles in the neutral lock position and engage the parking brake.

### 4.7 ENGAGING THE DECK DRIVE (CUTTER BLADES)

1. Set the throttle at about 3/4 speed. Do not attempt to engage the deck drive at high speed as this shortens the electric clutch life — use only moderate engine speed when engaging the deck drive.
2. Engage the deck drive by pulling out on the yellow switch, located on the instrument panel, to the engage position. See Figure 4-3.

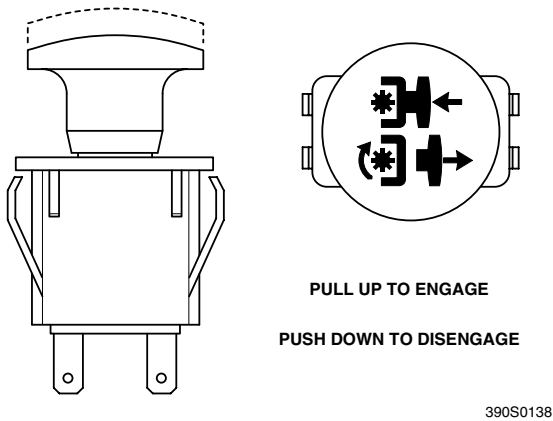

**Figure 4-3. Cutter Engage Switch**

**- NOTE -**

*A squealing noise may be heard when engaging or disengaging the deck drive. It is caused by the electric clutch plates meshing as the mower comes up to speed. This is normal.*

3. To disengage the deck drive, push the switch in to the disengage position.
4. Always operate the engine at full throttle to properly maintain cutting speed. If the engine starts to lug down, reduce the forward speed and allow the engine to operate at maximum RPM.

### 4.8 HILLSIDE OPERATION

#### **WARNING**

**DO NOT operate on steep slopes. To check a slope, attempt to back up it (with the cutter deck down). If the machine can back up the slope without the wheels slipping, reduce speed and use extreme caution. Under no circumstances should the machine be operated on slopes greater than 15 degrees. See Figure 2-2, Page 7 to help determine approximate slope of area to be mowed. ALWAYS FOLLOW OSHA APPROVED OPERATION.**

1. This mower has been designed for good traction and stability under normal mowing conditions. However, caution must be used when traveling on slopes, especially when the grass is wet. Wet grass reduces traction and steering control. The Roll-Over Protection System is standard equipment for this machine. See Section 2.6, page 6 of this manual for further details.
2. Stay two cut widths away from slopes, drop offs, ditches and retaining walls.
3. Some areas may need to be mowed with a walk-behind mower or string trimmer.
4. To prevent tipping or loss of control, do not start or stop suddenly, avoid unnecessary turns and travel at reduced speed. If tires lose traction, disengage blades and proceed slowly off the slope.
5. Avoid sudden starts when mowing uphill. Sudden starts may cause the machine to tip backwards.
6. Loss of traction may occur when traveling down hill. Weight transfers to the front of the machine and may cause the drive wheels to slip causing loss of braking or steering.
7. Keep tires properly inflated.
8. Use caution when operating the mower on an incline with the optional grass catcher installed.

## Section 4

### 4.9 PARKING THE MOWER

1. Park the machine on a flat, level surface only. Do not park the machine on an incline.
2. Place the steering control levers in the neutral position.
3. Disengage the cutter blades.
4. Slow the engine to idle speed.
5. Engage the parking brake.
6. Turn the ignition key to the OFF position and remove the key.

### 4.10 AFTER OPERATION

1. Wash the entire mower after each use. Do not use high pressure spray or direct the spray onto electrical components.

**- IMPORTANT -**

*Do not wash a hot or running engine. Cold water will damage the engine. Use compressed air to clean the engine if it is hot.*

2. Keep the entire mower clean to inhibit serious heat damage to the engine or hydraulic oil circuit.
3. Check the drive belts for proper alignment and any signs of wear. Correct and adjust if necessary.

## DANGER

**To avoid injury from burns, allow the mower to cool before removing the fuel tank cap and refueling.**

4. After the mower has cooled down, fill the fuel tank with fresh, clean fuel at the end of every day of operation. See Engine Owner's Manual for proper octane requirements.
5. Check the tire pressure. Adjust pressure if necessary.

### 4.11 REMOVING CLOGGED MATERIAL

## DANGER

### ROTATING BLADES

**NEVER PUT YOUR HANDS INTO THE DISCHARGE CHUTE FOR ANY REASON!**

**Shut off the engine and remove the key and only then use a stick or similar object to remove material if clogging has occurred.**

1. If the discharge chute becomes clogged, shut off the engine and remove the ignition key. Using a stick or similar item, dislodge the clogged material. Then resume normal mowing.

### 4.12 MOVING MOWER WITH ENGINE STOPPED

To "free-wheel" or move the mower around without the engine running, place the dump valve levers in the FREE-WHEEL position. See Figure 4-2, page 13. Disengage the parking brake and move the mower by hand. When the machine is in the desired position, engage the parking brake and place the dump valve levers in the DRIVE position. The dump valve levers must be returned to the DRIVE position to drive the mower.

### 4.13 RECOMMENDATIONS FOR MOWING

1. Do not mow with dull blades. A dull blade will tear grass, resulting in poor lawn appearance and reduced mowing power.

## WARNING

**DO NOT operate without Discharge Chute, Mulching Kit, or entire Grass Catcher properly installed.**

2. The discharge chute must not be removed and must be kept in the lowest position to deflect grass clippings and thrown objects downward. Direct the side discharge away from sidewalks or streets to minimize cleanup of clippings. When mowing close to obstacles, direct the discharge away from the obstacles to reduce the chance of property damage by thrown objects.
3. Cut grass when it is dry and not too tall. Do not cut grass too short (cut off 1/3 or less of existing grass for best appearance). Mow frequently.
4. Keep mower and discharge chute clean.
5. When mowing wet or tall grass, mow the grass twice. Raise the mower to the highest setting for the first pass and then make a second pass to the desired height.
6. Use a slow travel speed for trimming purposes.
7. Operate the engine at full throttle for best cutting. Mowing with a lower RPM causes the mower to tear the grass. The engine is designed to be operated at full speed.
8. Use the alternate stripe pattern for best lawn appearance. Vary the direction of the stripe each time the grass is mowed to avoid wear patterns in the grass.

### 4.14 ADJUSTING CUTTING HEIGHT

The mower deck can be adjusted from a height of 1 inch to 4-1/2 inches at 1/4-inch intervals. To adjust the cutting height:

## WARNING

**DO NOT adjust the cutting height with the mower blades rotating. Disengage the power to the cutter blades and then adjust cutting height.**

1. Disengage the power to the cutter blades.
2. Push the cutting height adjustment foot pedal all the way forward using your right foot until it locks in place. See Figure 4-4.

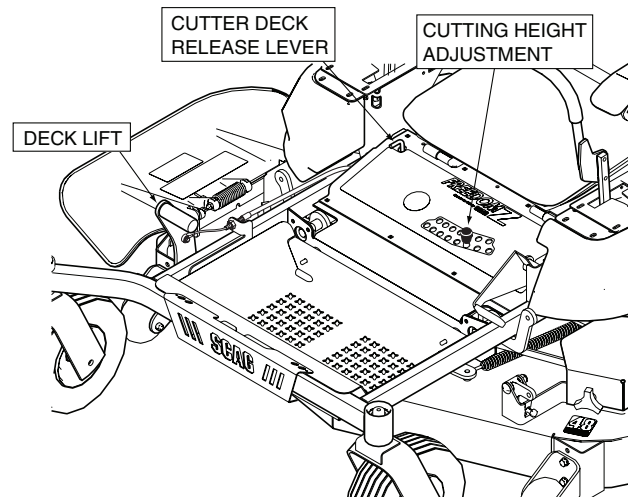

**Figure 4-4. Adjusting Cutting Height**

3. Insert the pin into the cutting height index at the desired cutting height. Push forward on the deck lift foot lever, hold in place and lift up on the deck release lever. See Figure 4-4. Slowly release the foot pedal. A deck height decal is located on the cutting height index as an aid in adjusting the deck to the desired height. See Figure 4-4.

### 4.15 TOWING (OPTIONAL HITCH ACCESSORY)

1. NEVER allow children or others in or on towed equipment.
2. Tow only with a machine that has a hitch designed for towing. Do not attach towed equipment except at the hitch point.
3. Follow manufacturer's recommendations for weight limit for towed equipment. 250/lbs. maximum towing weight.
4. NEVER TOW ON SLOPES. The weight of the towed equipment may cause loss of traction and loss of control.
5. Travel slowly and allow extra distance to stop.
6. Zero-turning with a trailer attached could cause damage to the trailer or mower.

## TROUBLESHOOTING CUTTING CONDITIONS

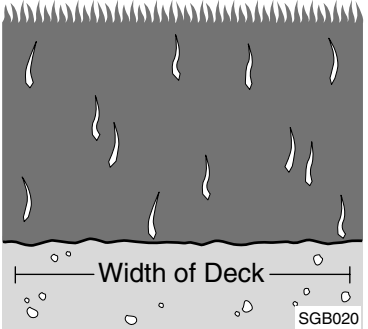
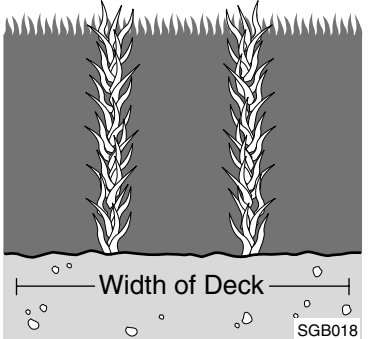
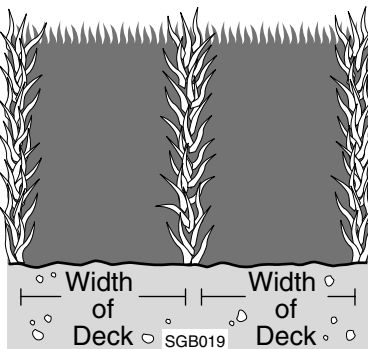
CONDITION	CAUSE	CURE
<p><b>STRINGERS - OCCASIONAL BLADES OF UNCUT GRASS</b></p> 	Low engine RPM	Run engine at full RPM
	Ground speed too fast	Slow speed to adjust for conditions
	Wet grass	Cut grass after it has dried out
	Dull blades, incorrect sharpening	Sharpen blades
	Deck plugged, grass accumulation	Clean underside of deck
	Belts slipping	Adjust belt tension
<p><b>STREAKING - STRIPS OF UNCUT GRASS IN CUTTING PATH</b></p> 	Dull, worn blades	Sharpen blades
	Incorrect blade sharpening	Sharpen blades
	Low engine RPM	Run engine at full RPM
	Belt slipping	Adjust belt tension
	Deck plugged, grass accumulation	Clean underside of deck
	Ground speed too fast	Slow speed to adjust for conditions
	Wet grass	Cut grass after it has dried out
	Bent blades	Replace blades
<p><b>STREAKING - STRIPS OF UNCUT GRASS BETWEEN CUTTING PATHS</b></p> 	Not enough overlapping between rows	Increase the overlap of each pass

### TROUBLESHOOTING CUTTING CONDITIONS (CONT'D)

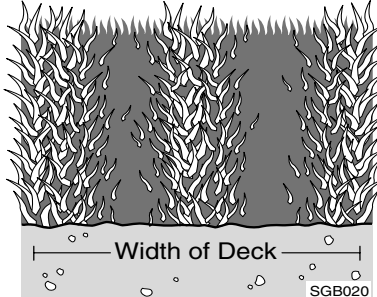
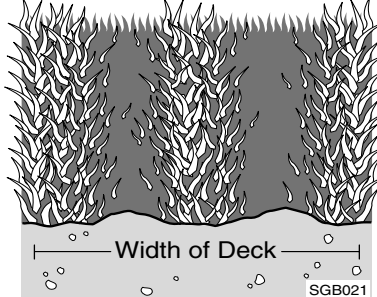
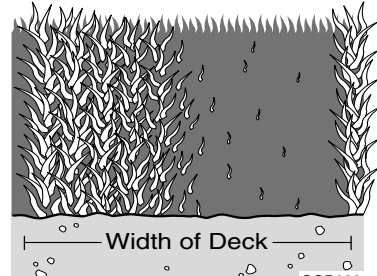
CONDITION	CAUSE	CURE
<p><b>UNEVEN CUT ON FLAT GROUND - WAVY HIGH-LOW APPEARANCE, SCALLOPED CUT, OR ROUGH CONTOUR</b></p>  <p style="text-align: right; font-size: small;">SGB020</p>	Lift worn from blade	Replace blade
	Blade upside down	Mount with cutting edge toward ground
	Deck plugged, grass accumulation	Clean underside of deck
	Too much blade angle (deck pitch)	Adjust pitch and level
	Deck mounted improperly	See your authorized SCAG dealer
	Bent spindle area	See your authorized SCAG dealer
	Dull blade	Sharpen blade
<p><b>UNEVEN CUT ON UNEVEN GROUND-WAVY APPEARANCE, HIGH-LOW SCALLOPED CUT, OR ROUGH CONTOUR</b></p>  <p style="text-align: right; font-size: small;">SGB021</p>	Uneven ground	May need to reduce ground speed, raise cutting height, and/or change direction of cut
<p><b>SLOPING RIDGE ACROSS WIDTH OF CUTTING PATH</b></p>  <p style="text-align: right; font-size: small;">SGB023</p>	Tire pressures not equal	Check and adjust tire pressure
	Wheels uneven	Check and adjust tire pressure
	Deck mounted incorrectly	See your authorized SCAG dealer
	Deck not level side-to-side	Check for level and correct

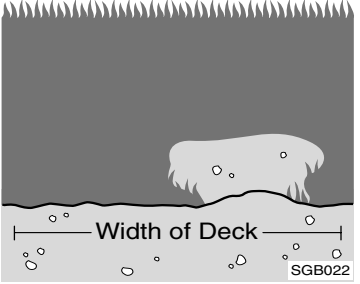
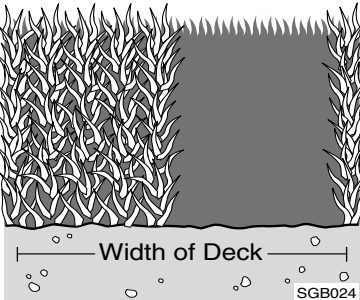
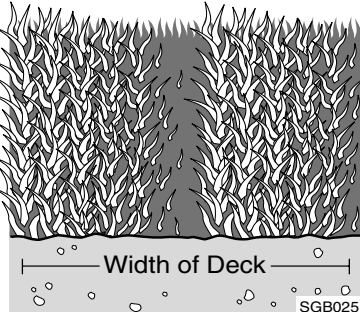

**TROUBLESHOOTING CUTTING CONDITIONS (CONT'D)**

CONDITION	CAUSE	CURE
<p><b>SCALPING - BLADES HITTING DIRT OR CUTTING VERY CLOSE TO THE GROUND</b></p> 	Low tire pressures	Check and adjust pressures
	Ground speed too fast	Slow speed to adjust for conditions
	Cutting too low	May need to reduce ground speed, raise cutting height, change direction of cut, and/or change pitch and level
	Rough terrain	May need to reduce ground speed, raise cutting height, and/or change direction of cut
	Wet grass	Cut grass after it has dried out
<p><b>STEP CUT - RIDGE IN CENTER OF CUTTING PATH</b></p> 	Blades not mounted evenly	Adjust pitch and level
	Bent blade	Replace blade
	Internal spindle failure	See your authorized SCAG dealer
	Mounting of spindle incorrect	See your authorized SCAG dealer
<p><b>SLOPE CUT - SLOPING RIDGES ACROSS WIDTH OF CUTTING PATH</b></p> 	Bent spindle mounting area	See your authorized SCAG dealer
	Internal spindle failure	See your authorized SCAG dealer
	Bent deck housing	See your authorized SCAG dealer

### ADJUSTMENTS

#### 6.1 PARKING BRAKE ADJUSTMENT

### WARNING

Do not operate the mower if the parking brake is not operable. Possible severe injury could result.

The parking brake linkage should be adjusted whenever the parking brake lever is placed in the “ENGAGE” position and the parking brake will not prevent the mower from moving. If the following procedures do not allow you to engage the parking brake properly, contact your Scag dealer for further brake adjustments.

1. Park the machine on a flat surface and block the caster wheels to prevent the machine from moving. Remove the ignition key.
2. Disengage the parking brake. See Figure 6-1.
3. Release the seat hold down latch and tilt the seat forward to gain access to the brake control linkage.
4. Remove the cotter pin securing the pivot to the brake control linkage. See Figure 6-2.
5. Push down on the brake control rod to disengage the parking brake and adjust the pivot until it meets the mounting hole. Insert the pivot into the brake control linkage and secure with the cotter pin.
6. Repeat steps 4 and 5 on the other side of the machine.
7. Test the parking brake.

**- NOTE -**

*If this procedure does not achieve proper brake adjustment, please contact your authorized Scag dealer.*

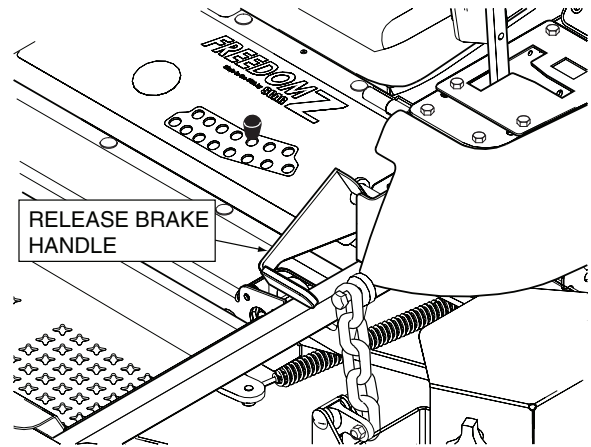

**Figure 6-1. Brake Adjustment**

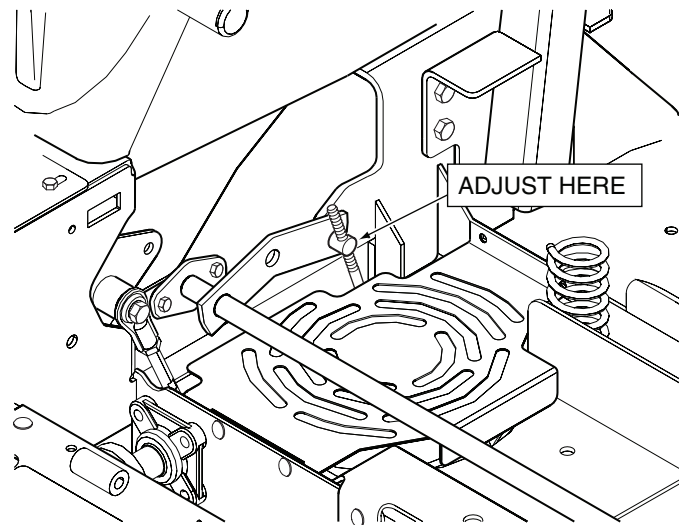

**Figure 6-2. Brake Rod Adjustment**

## Section 6

### 6.2 TRAVEL ADJUSTMENTS

Neutral or tracking adjustments will need to be made if:

A. The steering control levers are in the neutral position and the machine creeps forward or backward. (See Neutral Adjustment).

B. The steering control levers are in the full forward position and the mower pulls to one side or the other when traveling in a forward direction. (Tracking Adjustment, See Page 24).

#### NEUTRAL ADJUSTMENT

1. Be sure the dump valve levers are in the run position and the steering control levers are in the neutral lock position.
2. With an operator in the seat, start the engine and disengage the parking brake.

MOVE STEERING LEVER OUT TO THE NEUTRAL POSITION

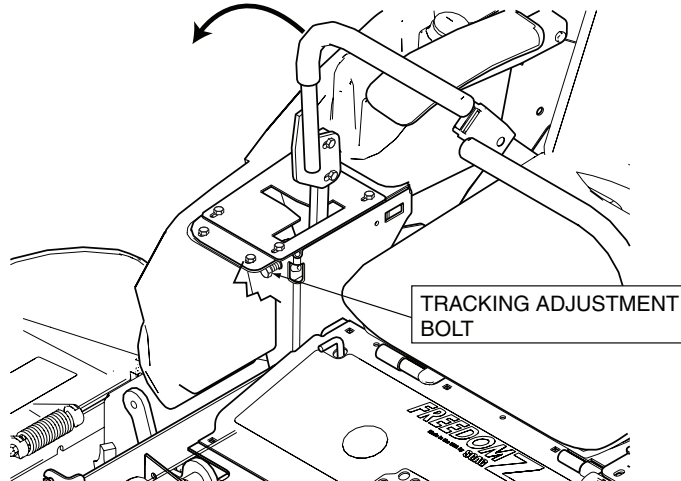

3. Run the engine at full operating speed and check if the machine creeps forward or backwards.
4. Tilt the seat forward and adjust the RH wheel by loosening the upper control linkage mounting bolt. See Figure 6-3. Allow the transmission to position the control linkage..
5. Tighten the upper control linkage mounting bolt and repeat for the LH wheel.
6. Actuate the steering control levers forward and reverse several times and return them to the neutral position.
7. Check that the drive wheels remained in neutral and readjust if necessary.

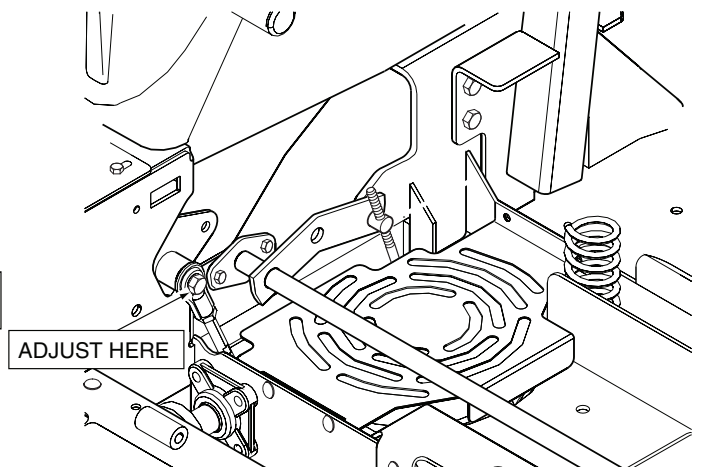

**Figure 6-3. Steering Control Rod Adjustment**

### TRACKING ADJUSTMENT

#### CAUTION

Stop the engine and remove the key from the ignition before making any adjustments. Wait for all moving parts to come to a complete stop before beginning work.

#### CAUTION

The engine and drive unit can get hot during operation causing burn injuries. Allow engine and drive components to cool before making any adjustments.

**- NOTE -**

*Before proceeding with this adjustment, be sure that the caster wheels turn plus pivot freely and that the tire pressure in the drive wheels is correct. If the tire pressure is not correct, the machine will pull to the side with the lower pressure.*

1. If at full speed the mower pulls right, it is an indication that the left wheel is turning faster than the right wheel. To adjust this condition, proceed as follows:
  - A. Stop the machine and place the steering control levers in the neutral position. Turn the tracking adjustment bolt for the LH pump inward (clockwise). This will cause the control rod to stroke the LH pump less, slowing down the LH wheel. See Figure 6-3.
2. If at full speed the mower pulls left, it is an indication that the right wheel is turning faster than the left wheel. To adjust this condition, proceed as follows:
  - A. Stop the machine and place the steering control levers in the neutral position. Turn the tracking adjustment bolt for the RH pump inward (clockwise). This will cause the control rod to stroke the RH pump less, slowing down the RH wheel. See Figure 6-3.

**- NOTE -**

*If after making the adjustment as outlined do not correct the tracking or neutral, contact your local Authorized Scag Power Equipment Dealer.*

### 6.3 THROTTLE CONTROL AND CHOKE ADJUSTMENTS

These adjustments must be performed by your Authorized Scag Power Equipment Dealer to ensure proper and efficient running of the engine. Should either need adjustment, contact your authorized Scag service center.

### 6.4 BELT ADJUSTMENT

#### WARNING

**Before removing any guards, shut the engine off and remove the ignition key.**

All drive belts are spring loaded and self-tensioning, however after the first 2, 4, 8 and 10 hours of operation, the belts should be checked for proper alignment and wear. Thereafter, check the belts after every 40 hours of operation or weekly, whichever occurs first.

#### WARNING

**If the pump drive belt fails, steering control will be lost which could result in serious injury or death. Replace the pump drive belt as needed or every 400 hours / 2 years, whichever occurs first.**

### 6.5 BELT ALIGNMENT

Belt alignment is important for proper performance of your Scag mower. If you experience frequent belt wear or breakage, see your authorized Scag service center for belt adjustment.

## Section 6

### 6.6 CUTTER DECK ADJUSTMENTS

Cutter deck level, pitch and height are set at the factory. However, if these adjustments should ever need to be made, the following procedures will aid in obtaining the proper cutter deck adjustment.

**- NOTE -**

*Before proceeding with the cutter deck adjustments, be sure that all tires are properly inflated.*

#### CUTTER DECK LEVEL

The cutter deck should be level from side-to-side for proper cutting performance. To check for level, be sure that the mower is on a flat, level surface, the tires are properly inflated and the cutter deck is set at the most common cutting height that you will use. On the RH side of the machine, check the distance from the top of the cutter deck to the floor. Next check the distance from the top of the cutter deck to the floor on the LH side of the machine. Both measurements should be the same. If the two measurements are different, the cutter deck level must be adjusted as follows:

1. If the cutter deck is lower on one side, loosen the elastic stop nuts securing the deck level links on the front and rear of the lower side. See Figure 6-4.

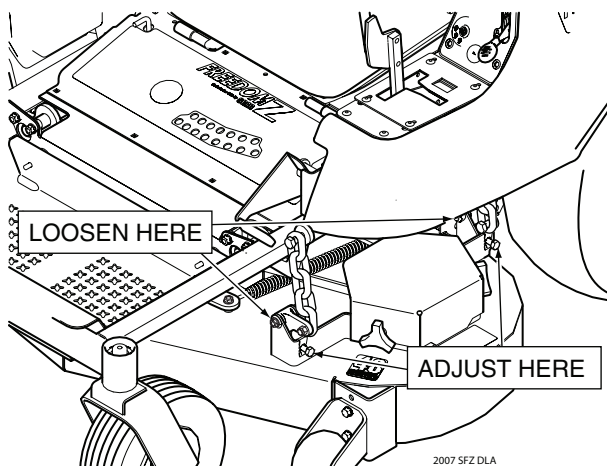

**Figure 6-4. Cutter Deck Level Adjustment**

2. Turn the adjustment bolts on the front and rear deck level links clockwise until the cutter deck is level between both sides. See Figure 6-4
3. Tighten the two (2) elastic stop nuts to secure the cutter deck in the proper position.

#### CUTTER DECK PITCH

The pitch of the cutter deck should be equal between the front and rear of the cutter deck for proper cutting performance. To check for proper deck pitch, be sure that the mower is on a flat, level surface and the tires are properly inflated.

Check the distance from the top of the cutter deck to the floor at the rear RH side of the cutter deck directly behind the cutter deck hanging chains. Next check the distance from the top of the cutter deck to the floor at the front RH side of the cutter deck directly in front of the cutter deck hanging chains. The measurement at the front of the cutter deck should be the same as the rear of the deck. Make these measurements at the LH side of the cutter deck also. If the measurement at the front of the deck is not the same, the cutter deck pitch must be adjusted as follows:

1. Loosen the elastic stop nuts securing the deck level links on the front of the cutter deck on both sides. See Figure 6-5 and 6-6.

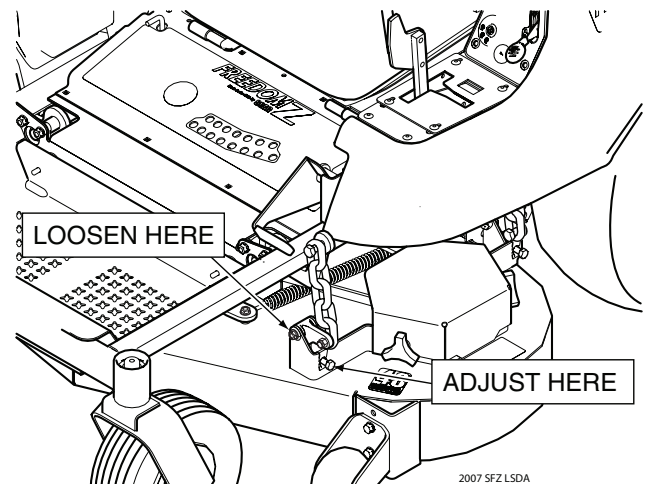

**Figure 6-5. Cutter Deck Pitch Adjustment**

2. Turn the adjustment bolts on both sides either clockwise to raise or counter-clockwise to lower the front of the cutter deck until the measurements are equal. Tighten the elastic stop nuts.

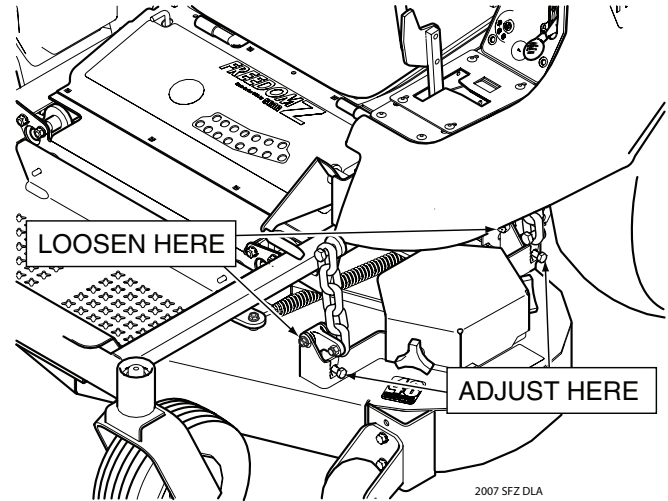
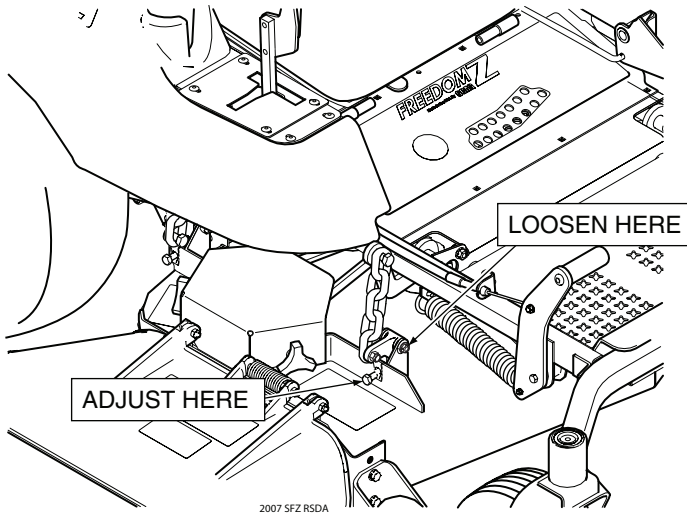

**Figure 6-6. Cutter Deck Pitch Adjustment**

**- NOTE -**

To prevent the cutter deck from teetering, all four (4) cutter deck hanging chains must have tension on them. If all four chains do not have tension on them and the deck teeters, you must readjust the cutter deck as outlined in the procedures above. All measurements should be taken from the top edge of the deck as the deck has an uneven bottom edge.

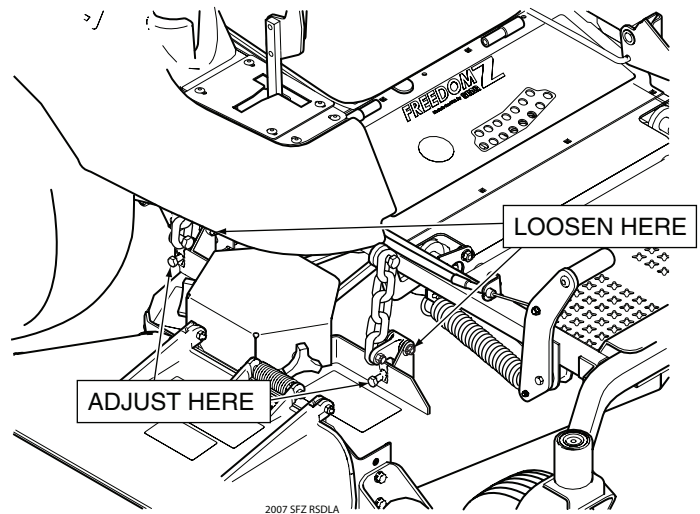

**Figure 6-7. Cutter Deck Height Adjustment**

### CUTTER DECK HEIGHT

The cutter deck height adjustment is made to ensure that the cutter deck is cutting at the height indicated on the cutting height index gauge. To check for proper deck height, be sure that the mower is on a flat, level surface and the tires are properly inflated.

1. Place the cutter deck in the 3" cutting position. Push on the cutter deck foot pedal and pull up on the cutter deck release lever to lower the cutter deck.
2. Check the measurement from the floor to the cutter blade tip. If the measurement is not 3", an adjustment can be made using the deck level links.
3. Loosen the elastic stop nuts securing the deck level links on both sides of the cutter deck. See Figure 6-7.

4. Turn the adjustment bolts equal amount of turns either clockwise to raise or counter-clockwise to lower the cutter deck until the measurement at the cutter blade is 3" on both sides.
5. Tighten the elastic stop nuts on the deck level links.

## Section 6

### 6.7 ELECTRIC CLUTCH ADJUSTMENT

The electric clutch serves two functions in the operation of the mower. In addition to starting and stopping the power flow to the cutter blades, the clutch also acts as a brake to assist in stopping blade rotation when the PTO is switched off or the operator presence circuit is interrupted.

When the clutch is disengaged, the air gap between the armature and rotor must be adjusted to fifteen thousandths of an inch, 0.015, for proper operation. The airgap adjustment is made at three bolts on the clutch. There are three inspection windows, one next to each adjusting bolt. See Figure 6-8.

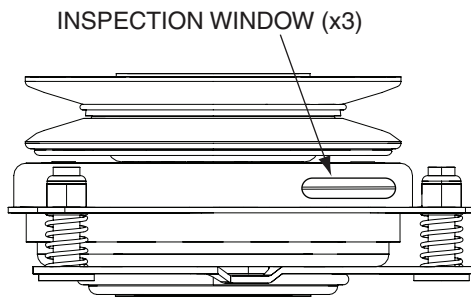

**Figure 6-8. Clutch Air Gap Adjustment**

1. Locate the inspection windows on the clutch.
2. Place a 0.015 feeler gauge in the slot between the rotor and the armature. See Figure 6-9.

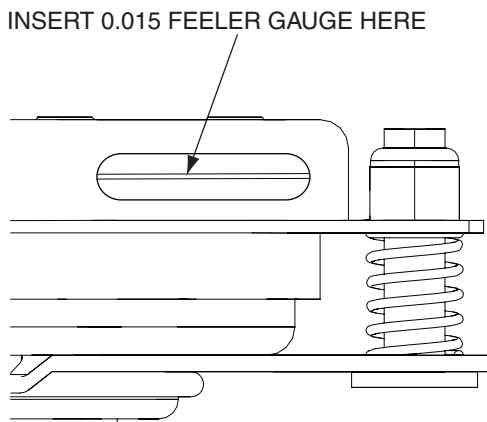

**Figure 6-9. Clutch Air Gap Adjustment**

3. Tighten or loosen the adjusting bolt as needed to achieve the 0.015 inch airgap. See Figure 6-10. Perform this operation at all three inspection windows.

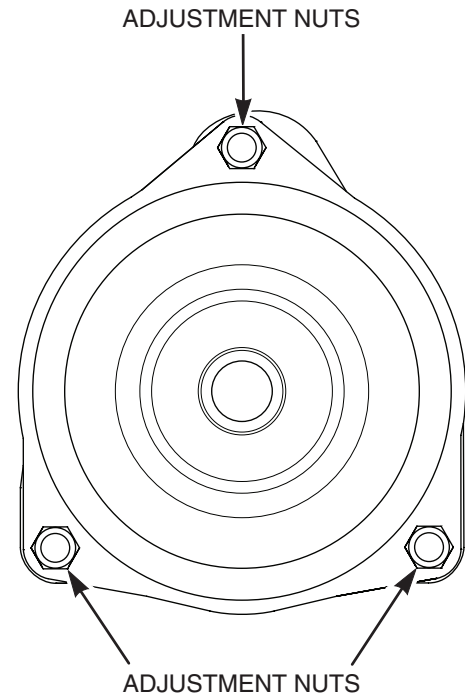

**Figure 6-10. Clutch Air Gap Adjustment**

This adjustment should be done every 500 hours of operation or annually, whichever comes first. In cases where the machine is heavily used, airgap settings should be checked more often.

If the air gap is too narrow, the clutch armature may drag when disengaged, resulting in premature failure.

If the air gap is too wide, the clutch may be slow to engage as the magnet must pull the armature in from a greater distance.

### MAINTENANCE

#### 7.1 MAINTENANCE CHART - RECOMMENDED SERVICE INTERVALS

BREAK-IN (FIRST 10)	HOURS						PROCEDURE	COMMENTS
	8	20	40	100	200	400		
X							Check all hardware for tightness	
X							Check hydraulic oil level	See paragraph 7.2
X							Check all belts for proper alignment	See paragraph 7.7
	X						Check engine oil level	See paragraph 7.3
	X						Check hydraulic hoses for leaks	Use extreme caution when checking the hydraulic hoses. See paragraph 2.6
	X						*Clean mower	See paragraph 7.10
	X						Check condition of blades	See paragraph 7.8
	X						Check tire pressure	See paragraph 7.9
	X						Inspect seat belt for wear or damage	See paragraph 2.5
	X						Check safety interlock system	See paragraph 4.2
		X					Change engine oil and filter	See paragraph 7.3
			X				Check battery, clean battery posts and cables	See paragraph 7.6
			X				Inspect pump drive belt. Replace every 400 hours or 2 years, whichever occurs first.	See paragraph 6.4 & 7.7
			X				Check belts for proper alignment	See paragraph 7.7
				X			Check condition of fuel lines	
				X			Change engine oil	See paragraph 7.3
				X			Drain hydraulic system, replace hydraulic oil and filters	Use SAE 20W50 Motor Oil. See paragraph 7.2
				X			*Clean air cleaner element	See paragraph 7.5
					X		Check all hardware for tightness	
					X		Change engine oil and filter	See paragraph 7.3
					X		Check hydraulic oil level	See paragraph 7.2
						X	Replace engine fuel filter	See paragraph 7.4
						X	Drain hydraulic system, replace hydraulic oil and filters	Use SAE 20W50 Motor Oil. See paragraph 7.2
						X	Adjust electric PTO clutch	See paragraph 6.7

\* Perform these maintenance procedures more frequently under extreme dusty or dirty conditions



## Section 7

### 7.2 HYDRAULIC SYSTEM

#### A. CHANGING HYDRAULIC OIL

The hydraulic system oil and filter should be changed after the first 75-100 hours of machine operation and every 400 hours or annually thereafter, whichever occurs first. The oil should also be changed if the color of the fluid has become black or milky. A black color and/or a rancid odor usually indicates possible overheating of the oil, and a milky color usually indicates water in the hydraulic oil.

**- IMPORTANT -**

*The hydraulic system oil should be changed if you notice the presence of water or a rancid odor to the hydraulic oil.*

1. Park the mower on a level surface and stop the engine.
2. Remove the three 1/4" filter guard screws and filter guard from both axles. See Figure 7-1. Clean any loose debris around the perimeter of the filter.

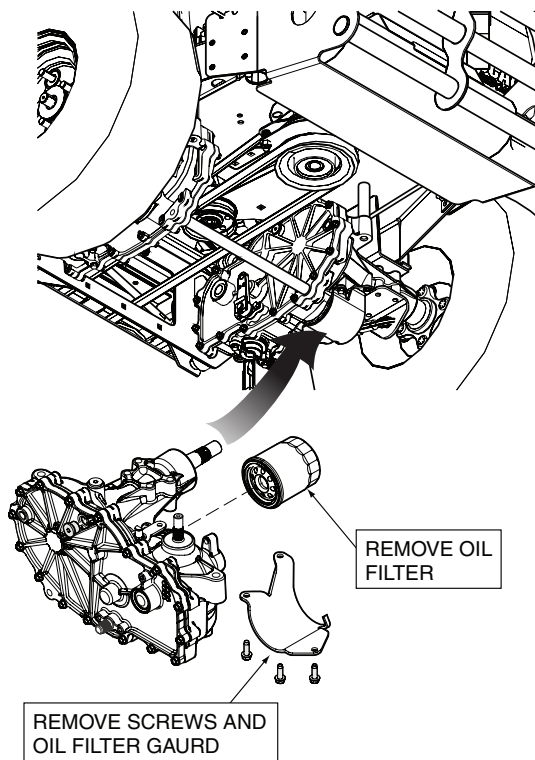

**Figure 7-1. Hydraulic Oil Filter and Drain Plug**

3. Place a suitable container under the hydraulic oil filters.

4. Remove the hydraulic filters from both axles and allow the fluid to drain into the container. Properly discard the oil when the system has drained completely. See Figure 7-1.
5. Once the hydraulic system has drained, install new hydraulic oil filters to both axles by hand, turn 3/4 to one complete turn after filter gasket contacts the filter base.
6. Reinstall the filter guards and torque the screws to 65 in/lbs.
7. Remove the side top port plug from both axles before filling with oil. See Figure 7-2.

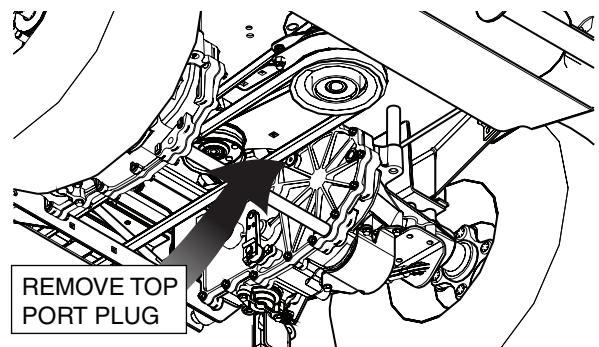

**Figure 7-2. Top Port Plug Location**

8. Remove the fill port plug from the top of both transaxle. See Figure 7-3. Fill each transaxle with Scag Hydraulic System Oil (p/n 486255 - 1 Quart or p/n 486254 - 1 Gallon) oil until the oil just appears at the bottom of each axle top port. Approximately 2 quart capacity per transaxle (4 quart total). Reinstall the top port plugs and torque to 180 in/lbs.

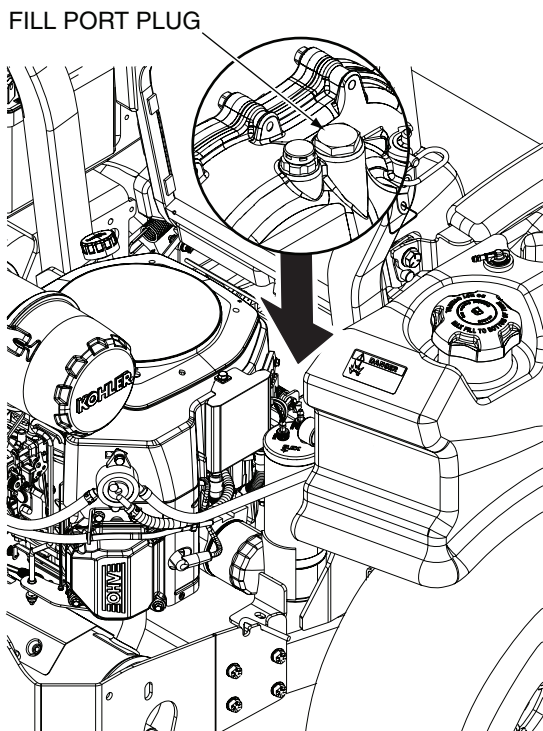

**Figure 7-3. Right Side Fill Port Plug**

9. Reinstall the fill port plug on the top of the transaxle.
10. The hydraulic system will need to be purged of all air. Raise the rear of the machine so the drive wheels are off the ground. Use jackstands and block the front caster wheels to prevent the machine from moving.
11. Move the dump valve controls to the "freewheel" position by pulling the levers backward and locking in the notch (towards the rear of the mower). See Figure 7-4.

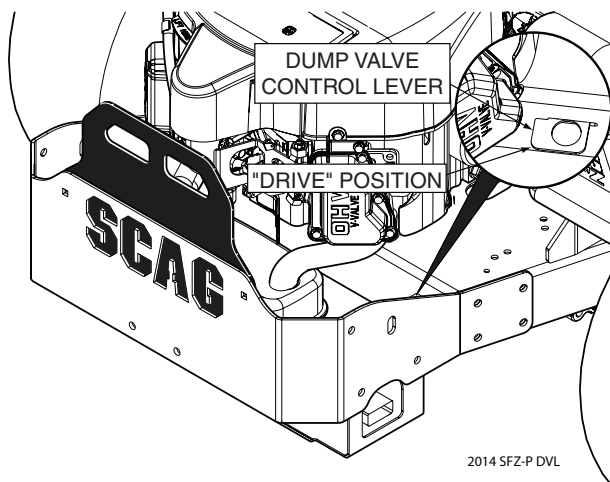

**Figure 7-4. Dump Valve Control Lever**

12. While in the operator's position, start the engine and disengage the parking brake.
13. Run the engine at 1/2 throttle and move the steering control levers to full forward and reverse 5 to 6 times.
14. Engage the parking brake. Move the dump valve control levers to the "drive" position. See Figure 7-4.
15. While in the operator's position, run the engine at 1/2 throttle. Release the parking brake, move the steering control levers to full forward and reverse 5 to 6 times. It may be necessary to repeat steps 12 to 15 until the air is completely purged from the system.
16. After the purge process is complete, remove the side top port plug from both transaxles to check the oil level. See Figure 7-2. If necessary, fill oil until the oil just appears at the bottom of each axle top port.

### 7.3 ENGINE OIL

#### A. CHECKING ENGINE CRANKCASE OIL LEVEL

The engine oil level should be checked after every 8 hours of operation or daily as instructed in the Engine Operator's Manual furnished with this mower.

#### B. CHANGING ENGINE CRANKCASE OIL

After the first 20 hours of operation, change the engine crankcase oil and replace the oil filter. Thereafter, change the engine crankcase oil after every 100 hours of operation or bi-weekly, whichever occurs first. Refer to the Engine Operator's Manual furnished with this mower for instructions.

#### C. CHANGING ENGINE OIL FILTER

After the first 20 hours of operation, replace the engine oil filter. Thereafter, replace the oil filter after every 200 hours of operation or every month, whichever occurs first. Refer to Engine Operator's Manual for instructions.

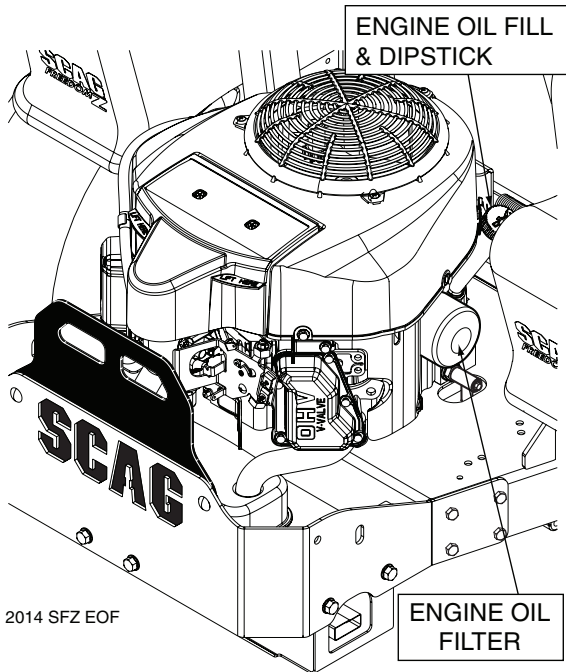

2014 SFZ EOF

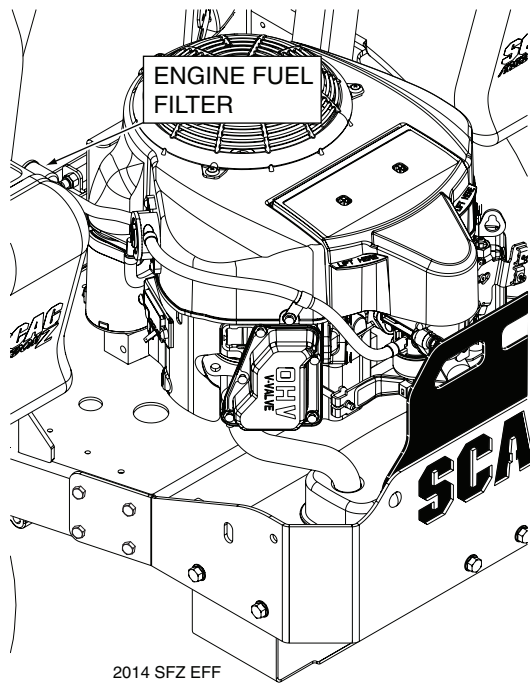

2014 SFZ EFF

Figure 7-5. Oil Fill / Dipstick, Oil Filter, Fuel Filter

### 7.4 ENGINE FUEL SYSTEM

**⚠ DANGER**

To avoid injury from burns, allow the mower to cool before removing the fuel tank cap and refueling.

#### A. FILLING THE FUEL TANK

Fill to the bottom of the filler neck insert (approximately 6-1/2 gallons on SPZ52/61 indicating Full (F) on the fuel gauge) at the beginning of each operating day. See Figure 7-6. Do not overfill. Use clean, fresh unleaded gasoline with a minimum octane rating of 87 and a maximum of 10% Ethanol.

**DO NOT use E85 Fuel. Using E85 Fuel will cause severe damage to the engine.**

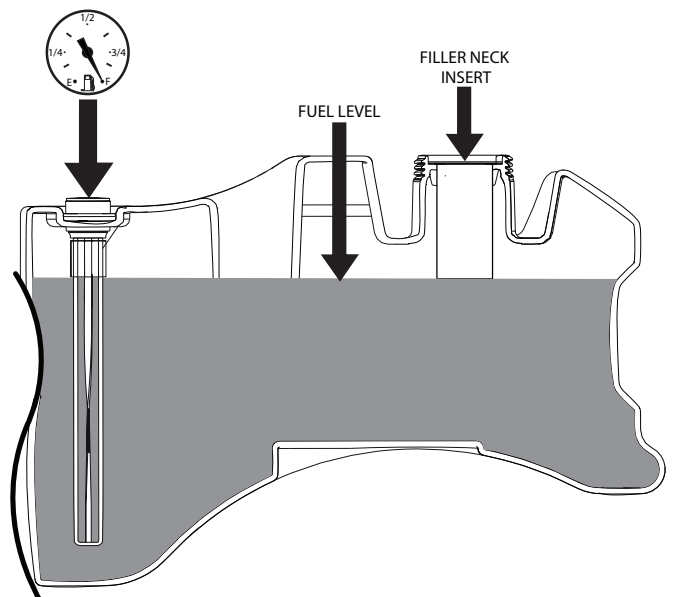

Figure 7-6. C.A.R.B. / EPA Phase 3 Fuel Level

To avoid personal injury or property damage, use extreme care in handling gasoline. Gasoline is extremely flammable and the vapors are explosive.

Extinguish all cigarettes, cigars, pipes and other sources of ignition.

1. Use only an approved gasoline container.
2. Never remove the gas cap or add fuel with the

engine running. Allow the engine to completely cool before fueling.

3. Never fuel the machine indoors or in an enclosed trailer.
4. Never store the machine or fuel container where there is an open flame, spark or pilot light such as on a water heater or other appliances.
5. Never fill containers inside a vehicle or on a truck or trailer bed with a plastic liner. Always place containers on the ground away from your vehicle before filling.
6. Remove the machine from the truck or trailer and fuel on level ground. If this is not possible, then refuel the machine with a portable container, rather than from a gasoline dispenser nozzle.
7. Keep the nozzle in contact with the rim of fuel tank or container opening at all times until fueling is complete. Do not use a nozzle lock-open device.
8. If fuel is spilled on clothing, change clothing immediately and wash affected skin.
9. Replace gas cap and tighten the fuel cap until it ratchets.

### B. REPLACING IN-LINE FUEL FILTER ELEMENTS

The engine fuel filter should be replaced after every 400 hours of operation or annually, whichever occurs first. See Figure 7-7.

1. Close the shut-off valve.
2. Remove and replace the engine fuel filter. Open the fuel shut-off valve.

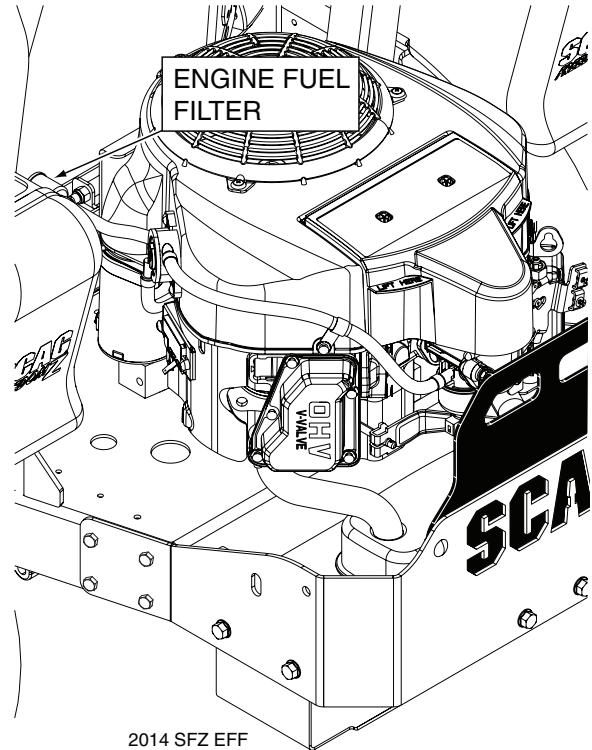

**Figure 7-7. Fuel Filter**

## 7.5 ENGINE AIR CLEANER

### A. CLEANING AND/OR REPLACING AIR CLEANER ELEMENT

For any air cleaner, the operating environment dictates the air cleaner service periods. Inspect and clean the air cleaner element after every 100 hours of operation or bi-weekly, whichever occurs first and replace the element if required.

**- NOTE -**

*In extremely dusty conditions it may be necessary to check the element once or twice daily to prevent engine damage.*

1. Loosen the two bolts securing the air cleaner cover to the air cleaner assembly and remove the cover. Set aside.
2. Remove the air cleaner and inspect.
3. Clean or replace the air cleaner and foam pre-cleaner as recommended by the engine manufacturer.
4. Replace the air cleaner cover and secure.

## Section 7

### 7.6 BATTERY

#### **WARNING**

Lead-acid batteries produce flammable and explosive gases. To avoid personal injury when checking, testing or charging batteries, **DO NOT** use smoking materials near batteries. Keep arcs, sparks and flames away from batteries. Provide proper ventilation and wear safety glasses.

#### **WARNING**

Battery posts, terminals, and related accessories contain lead and lead compounds, chemicals known to cause cancer and reproductive harm. Wash hands after handling.

#### **WARNING**

Electric storage battery fluid contains sulfuric acid which is **POISON** and can cause **SEVERE CHEMICAL BURNS**. Avoid contact of fluid with eyes, skin, or clothing. Use proper protective gear when handling batteries. **DO NOT** tip any battery beyond 45° angle in any direction. If fluid contact does occur, follow first aid suggestions below.

##### BATTERY ELECTROLYTE FIRST AID

**External Contact** — Flush with water.

**Eyes** — Flush with water for at least 15 minutes and get medical attention immediately.

**Internal** — Drink large quantities of water. Follow with Milk Of Magnesia, beaten egg, or vegetable oil. Get medical attention immediately. In case of internal contact, **DO NOT** give fluids that would induce vomiting.

### A. CHARGING THE BATTERY

Refer to the battery charger's manual for specific instructions.

Under normal conditions the engine's alternator will have no problem keeping a charge on the battery. If the battery has been completely discharged for a long period of time, the alternator may not be able to recharge the battery, and a battery charger will be required.

**DO NOT** charge a frozen battery. It may explode and cause injury. Let the battery warm before attaching a charger.

Whenever possible, remove the battery from the mower before charging and make sure the electrolyte covers the plates in all cells.

#### **WARNING**

**BATTERIES PRODUCE EXPLOSIVE GASES. Charge the battery in a well ventilated space so gases produced while charging can dissipate.**

Charging rates between 3 and 50 amperes are satisfactory if excessive gassing or spewing of electrolyte does not occur or the battery does not feel excessively hot (over 125°F). If spewing or gassing occurs or the temperature exceeds 125°F, the charging rate must be reduced or temporarily stopped to permit cooling.

### B. JUMP STARTING

1. The booster battery must be a 12 volt type. If a vehicle is used for jump starting, it must have a negative ground system.
2. When connecting the jumper cables, connect the positive cable to the positive battery post, then connect the negative cable to the negative battery post.

### 7.7 DRIVE BELTS

All drive belts are spring-loaded and self-tensioning, however after the first 2, 4, 8 and 10 hours of operation, the belts should be checked for proper alignment and wear. Thereafter, check the belts after every 40 hours of operation or weekly, whichever occurs first.

**- NOTE -**

*If you experience frequent belt wear or breakage, see your authorized Scag service center for belt adjustment.*

### WARNING

**If the pump drive belt fails, steering control will be lost which could result in serious injury or death. Replace the pump drive belt as needed or every 400 hours / 2 years, whichever occurs first.**

### 7.8 CUTTER BLADES

#### A. BLADE INSPECTION

1. Remove the ignition key before servicing the blades.
2. Raise the mower deck to the highest position. Place the lanyard pin in the highest cutting height position to prevent the cutter deck from falling.

### WARNING

**Always wear proper hand and eye protection when working with cutter blades.**

3. Check the cutter blades for straightness. If the cutter blades appear bent, they will need to be replaced.
4. Check the cutter blades for wear. If any part of the cutter blade is worn to 1/2 its original thickness, replace the cutter blade.

### WARNING

**Do not attempt to straighten a bent blade, and never weld a broken or cracked blade. Always replace it with a new blade to assure safety.**

5. If a blade cutting edge is dull or nicked, it should be sharpened. Remove the blades for sharpening. See "Blade Replacement."

**- NOTE -**

*Keep the blades sharp. Cutting with dull blades not only yields a poor mowing job, but slows the cutting speed of the mower and causes extra wear on the engine and the blade drive by pulling hard.*

#### B. BLADE SHARPENING

**- NOTE -**

*If possible, use a file to sharpen the blade. Using a wheel grinder may burn the blade.*

**- NOTE -**

*DO NOT sharpen the blades beyond 1/3 of the width of the blade. See Figure 7-8.*

1. Sharpen the cutting edge at the same bevel as the original. See Figure 7-8. Sharpen only the top of the cutting edge to maintain sharpness.

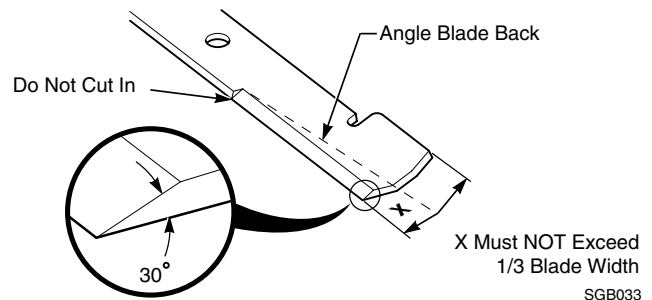

**Figure 7-8. Blade Sharpening**

2. Check the balance of the blade. If the blades are out of balance, vibration and premature wear can occur. The cutter blades should be balanced to 1-1/2 oz-in. See your authorized Scag dealer for blade balancing or special tools, if you choose to balance your own blades.

## Section 7

### C. BLADE REPLACEMENT

#### **WARNING**

**Always wear proper hand and eye protection when working with cutter blades.**

1. Remove the ignition key before replacing the blades.
2. Raise the mower deck to the highest position. Place the lanyard pin in the highest cutting height position to prevent the cutter deck from falling.
3. Secure the cutter blades to prevent them from rotating, (use the optional Blade Buddy tool P/N 9212, to assist in securing the cutter blades), remove the blade attaching bolt. Remove the cutter blade, bolt, lockwasher and flatwasher from the spindle shaft. See Figure 7-9.

#### **CAUTION**

**Inspect the cutter blade spacer(s) and washer for wear and/or cupping. Replace the worn parts. Worn spacer(s) and/or washer will not allow proper tightening of the cutter blade and can lead to cutter blade failure, personal injury or property damage.**

4. To install the new cutter blade, put the lockwasher and flatwasher onto the blade bolt and slide the bolt into the hole in the cutter blade.

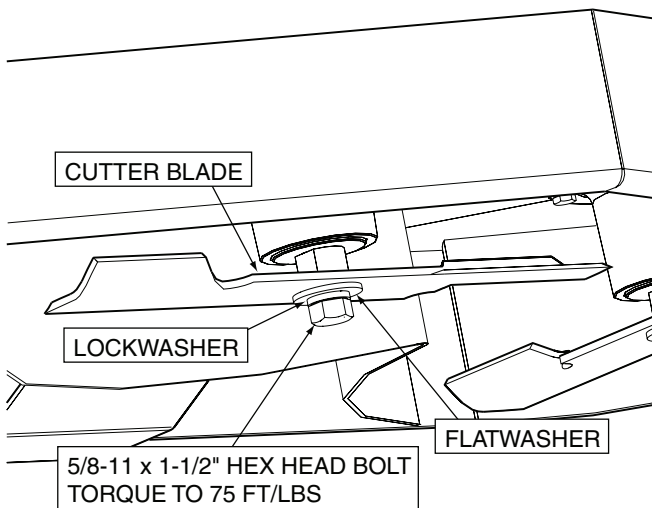

**Figure 7-9. Blade Replacement**

#### - NOTE -

*Be sure that the blade is installed with the lift wing toward the top.*

5. Install the cutter blade onto the cutter spindle shaft. Secure the blades from rotating and torque to 75 ft/lbs. See Figure 7-9.

### 7.9 TIRES

Check the tire pressures after every 8 hours of operation or daily.

Caster Wheels	25 PSI
Drive Wheels	8 PSI

### 7.10 BODY, DECK, AND UPHOLSTERY

#### **CAUTION**

**Do not wash any portion of the equipment while it is hot. Do not wash the engine; use compressed air.**

1. After each use, wash the mower and cutter deck. Use cold water and automotive cleaners. Do not use pressure cleaners.
2. Do not spray electrical components.
3. Use a mild soap solution or a vinyl/rubber cleaner to clean the seat.
4. Repair damaged metal surfaces using Scag touch-up paint available from your authorized Scag dealer. Wax the mower for maximum paint protection.

## ILLUSTRATED PARTS LIST

### 8.1 SCAG APPROVED ATTACHMENTS AND ACCESSORIES.

Attachments and accessories manufactured by companies other than Scag Power Equipment are not approved for use on this machine.

Scag approved attachments and accessories:

- GC-SFZ (p/n 901K, requires p/n 9069 (48") or 9070 (52") baffle kit)
- Mulch Plate (p/n 9298, 9299)
- Hurricane Mulch (p/n 9293, 9294)
- Hitch (p/n 9242)
- Freedom Striper (p/n 923F, requires p/n 921S)
- Blade Buddy (p/n 9212)
- SFZ Lights (LED p/n 924A)
- 8" Chrome Wheel Covers (set of 2) (p/n 920H)
- SFZ/SFZP/SPZ Fold ROPS (9518)

Scag Premium Lubricants:

- Chassis Grease (p/n 486257)
- 20W50 Oil - Gallon (p/n 486254)
- 20W50 Oil - Quart (p/n 486255)



NOTES

### 48H & 52H CUTTER DECKS

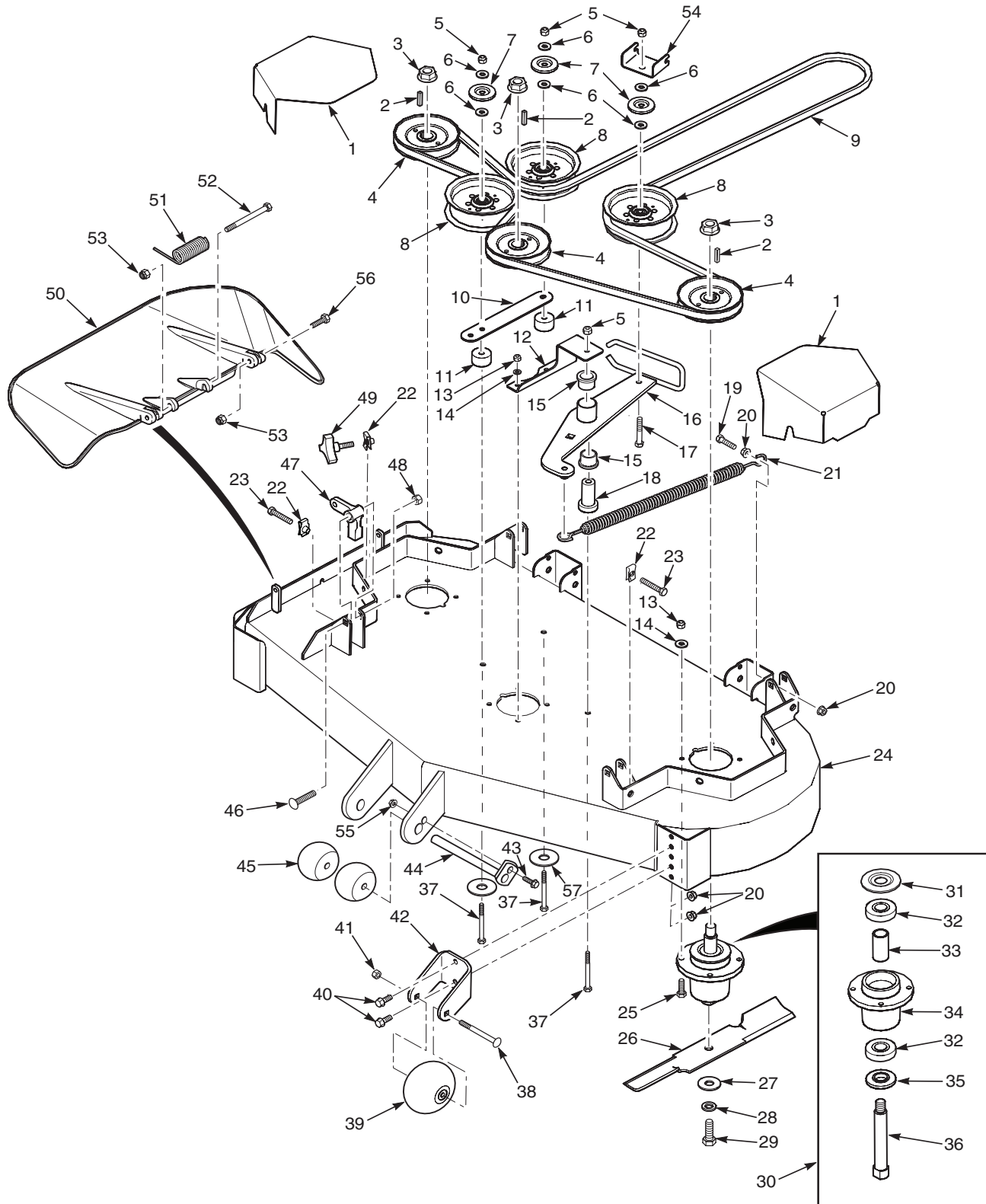

## 48H &amp; 52H CUTTER DECKS

	Part No.	Description	48	52		Part No.	Description	48	52
1	424528	Belt Cover	x	x	27	04043-06	Flatwasher, 5/8-.688 x 1.75 x .134 HD	x	x
2	04063-01	Key, 1/4 x 1/4 x 1-1/4"	x	x	28	04030-07	Lockwasher, 1/2 Spring	x	x
3	04112-06	Nut, 3/4-16 Spiral Lock	x	x	29	04001-121	Bolt, Hex Head 5/8-11 x 1-1/2"	x	x
4	483323	Pulley, 5.13" OD - 25mm Bore	x		30	461950	Spindle Assembly	x	x
	483324	Pulley, 5.73" OD - 25mm Bore		x	31	483304	Debris Shield	x	x
5	04021-09	Nut, Elastic Stop 3/8-16	x	x	32	483303	Bearing	x	x
6	04043-04	Flatwasher, 3/8-.391 x .938 x .105	x	x	33	43693	Spacer	x	x
7	424367	Dust Shield	x	x	34	462014	Spindle Housing Assembly (Incl. item #32, 33)	x	x
8	483422	Pulley, 5" Idler	x	x	35	43694	Protector, Bearing	x	x
9	483325	Belt, Cutter Deck	x		36	43695	Shaft, Spindle	x	x
	483326	Belt, Cutter Deck		x	37	04001-77	Bolt, Hex Head 3/8-16 x 3-1/2"	x	x
10	424479	Brace, Pulley	x	x	38	04003-26	Bolt, Carriage 3/8-16 x 4"	x	x
11	43711	Spacer	x	x	39	481632	Wheel, Anti-Scalp	x	x
12	424548	Support, Idler Pivot	x		40	04017-27	Bolt, Hex Head 3/8-16 x 1" Ser. Flg.	x	x
	424547	Support, Idler Pivot		x	41	04021-05	Nut, Center Lock 3/8-16	x	x
13	04021-22	Nut, Elastic Stop	x	x	42	427865	Bracket, Anti-Scalp	x	x
14	04030-03	Lockwasher, 5/16 Spring	x	x	43	04001-09	Bolt, Hex Head 5/16-18 x 1"	x	x
15	483453-03	Bearing	x	x	44	451926	Shaft Weldment	x	x
16	462037	Idler Arm (incl. item #15)	x	x	45	482295	Wheel, Anti-Scalp	x	x
17	04001-31	Bolt, Hex Head 3/8-16 x 2-1/2"	x	x	46	04003-42	Bolt, Carriage 7/16-14 x 2-1/4"	x	x
18	43708	Pivot, Idler	x	x	47	483361	Lever, Deck Level	x	x
19	04001-136	Bolt, Hex Head 3/8-16 x 1-1/2 Gr.8	x	x	48	04021-11	Nut, Elastic Stop 7/16-14	x	x
20	04019-04	Nut, Serrated Flange 3/8-16	x	x	49	481625-01	Knob w/Stud	x	x
21	483375	Spring, Idler	x	x	50	462031	Discharge Chute Assy. SFZ48	x	x
22	04110-03	U-Nut, 3/8-16	x	x		462032	Discharge Chute Assy. SFZ52		
23	04107-04	Bolt, Hex Head 3/8-16 x 2" Special Lock	x	x	51	482245	Spring, Discharge Chute	x	x
24	463307	Cutter Deck w/Decals, SFZ48	x		52	04001-154	Bolt, Hex Head 5/16-18 x 4-3/4"	x	x
	463308	Cutter Deck w/Decals, SFZ52		x	53	04021-10	Nut, Elastic Stop 5/16-18	x	x
25	4001-11	Bolt, Hex Head 5/16-18 x 1-1/2"	x	x	54	424615	Bracket, Belt Guide	x	x
26	482877	Cutter Blade, 16-1/2"	x		55	04019-03	Nut, Serrated Flange 5/16-18	x	x
	482878	Cutter Blade, 18"		x	56	04001-12	Bolt, Hex Head 5/16-18 x 1-3/4"	x	x
					57	04041-38	Flatwasher, 3/8-.406 x 2.25 x .1875	x	x

### CUTTER DECK CONTROLS - SFZ48H / 52H

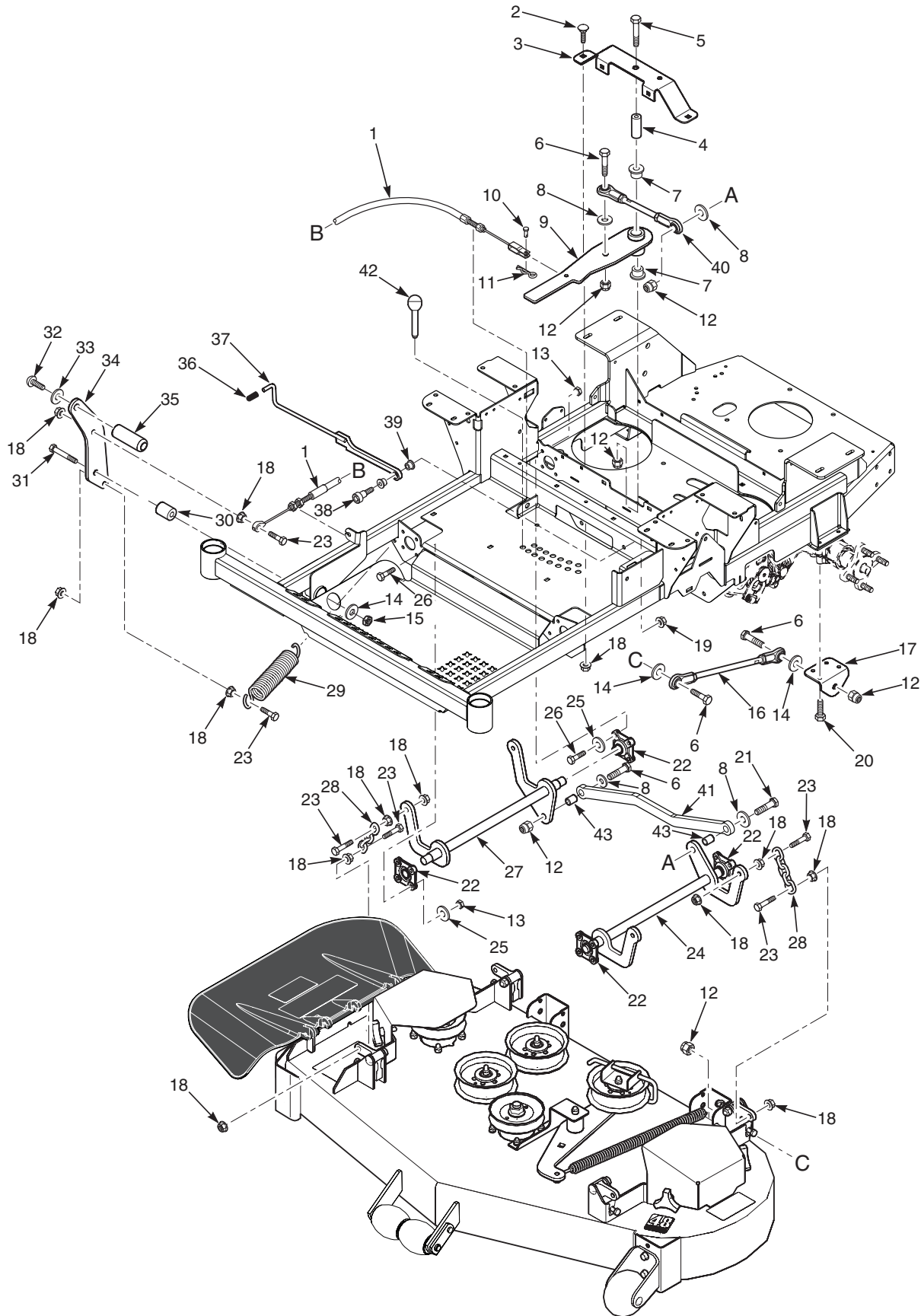

## CUTTER DECK CONTROLS - SFZ48H / 52H

Ref. No.	Part No.	Description
1	483341	Cable, Deck Lift
2	04003-31	Bolt, Carriage 3/8-16 x 3/4"
3	424476	Support, Idler Arm
4	43710	Spacer, Deck Lift Pivot
5	04001-90	Bolt, Hex Head 1/2-13 x 3-3/4"
6	04001-72	Bolt, Hex Head 1/2-13 x 2"
7	483453-03	Bearing
8	04040-07	Flatwasher, 1/2-.531 x 1.06 x .095
9	462215	Deck Lift Bellcrank Assembly
10	04064-17	Clevis Pin, 5/16 x 3/4"
11	04062-01	Hair Pin, .094 x 1.62"
12	04021-07	Nut, Elastic Stop 1/2-13
13	04117-01	Nut, Flange, Elastic Stop 5/16-18
14	04040-13	Flatwasher, 1/2-.562 x 1.375 x .109
15	04021-09	Nut, Center Lock 1/2-13
16	483332	Linkage, Push Arm
17	424489	Bracket, Push Arm Link
18	04019-04	Nut, Serrated Flange 3/8-16
19	04021-09	Nut, Elastic Stop 3/8-16
20	04001-49	Bolt, Hex Head 5/16-18 x 3"
21	04001-74	Bolt, Hex Head 1/2-13 x 3"
22	483334	Bearing, Deck Lift
23	04001-20	Bolt, Hex Head 3/8-16 x 1-1/2"
24	451868	Weldment, Deck Lift LH
25	04040-14	Flatwasher, 1/4-.312 x .750 x .065
26	04001-09	Bolt, Hex Head 5/16-18 x 1"
27	451867	Weldment, Deck Lift RH
28	482628	Chain, Deck lift
29	483374	Spring, Deck Lift
30	43710	Sleeve, Deck Lift Pivot
31	04001-74	Bolt, Hex Head 1/2-13 x 3"
32	04105-01	Bolt, Head Socket 5/8-11 x 1-1/2"
33	04030-07	Lockwasher, 5/8 Spring
34	424535	Pedal, Foot Bracket
35	424504	Foot Pedal
36	483492	Grip, Deck Latch
37	491254	Weldment, Deck Latch
38	04009-06	Bolt, Shoulder 1/2 x 1/2
39	483453-10	Bearing
40	483328	Linkage Assembly, Deck Lift
41	426579	Link, Deck Lift
42	483498	Pin, Height Adjuster
43	43957	Sleeve

### SHEET METAL COMPONENTS

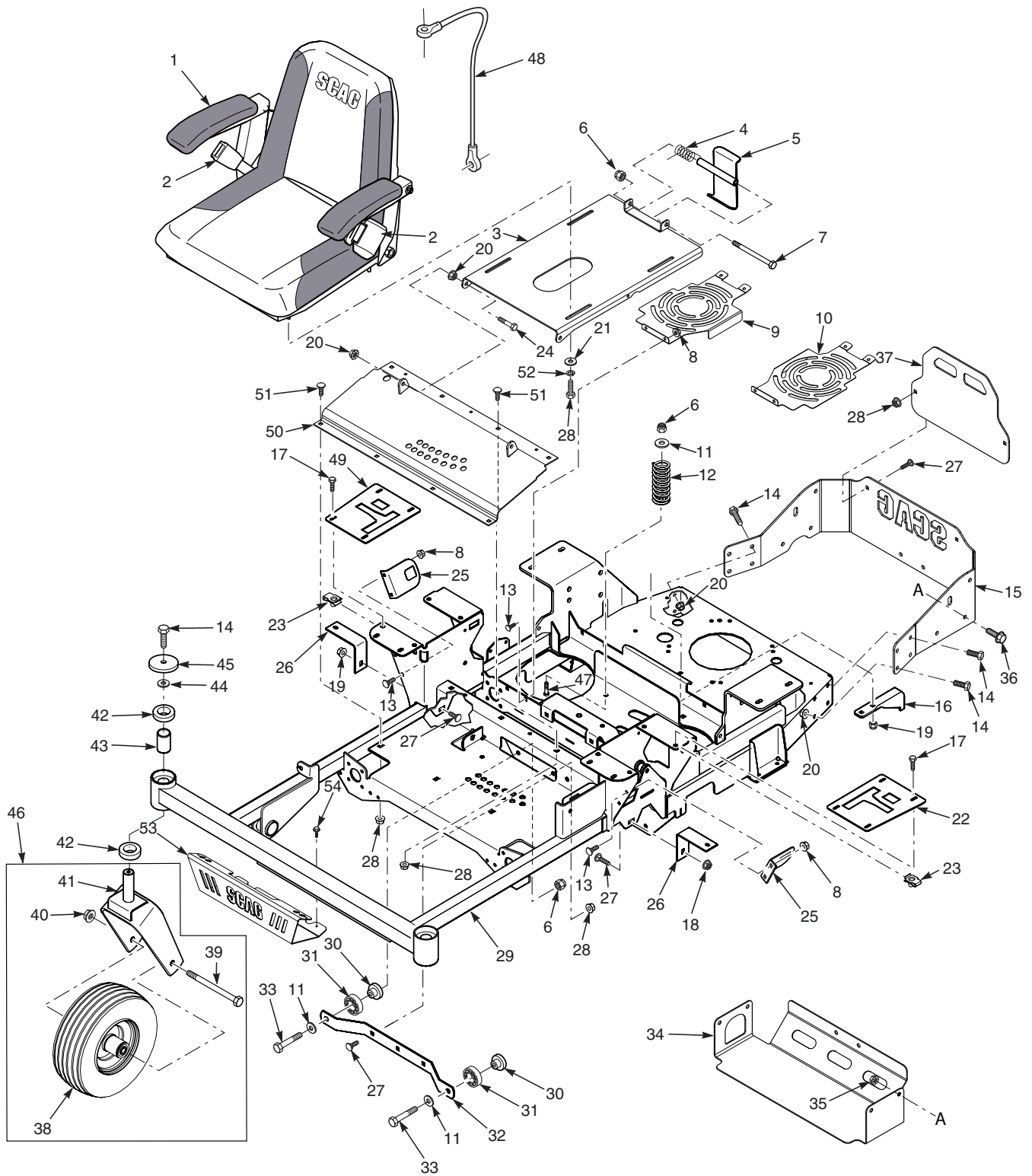

## SHEET METAL COMPONENTS

	Part No.	Description	Ref. No.	Part No.	Description
1	486713	Seat Assembly	27	04003-12	Bolt, Carriage 5/16-18 x 3/4"
	486773	Back Cushion	28	04001-08	Bolt, Hex Head 5/16-18 x 3/4"
	486774	Cover, Bottom Cushion	29	463316	Main Frame w/Decals
	486776	Arm Rest Kit	30	43703	Spacer, Bearing
	486775	Cap, Actuator Switch	31	483379	Bearing
	483473	Switch	32	424480	Support, Deck Guide
2	485164	Seat Belt Assembly, Retractable	33	04001-21	Bolt, Hex Head 3/8-16 x 1-3/4"
	461990	Hardware Package, Mounting	34	427871	Heatshield
3	463296	Seat Base w/Decal	35	04019-04	Nut, Serrated Flange 3/8-16
4	483371	Spring, Seat Latch	36	04017-27	Bolt, Hex Head Serrated Flange 3/8-16 x 1"
5	451883	Seat Latch	37	427862	Engine Guard
6	04021-09	Nut, Elastic Stop 3/8-16	38	486310	Caster Wheel Assembly (INCL. Rim - 486311)
7	04001-100	Bolt, Hex Head 3/8-16 x 6"		485941	Tire, 11 x 6.00-5
8	04019-02	Nut, Serrated Flange 1/4-20	39	04001-134	Bolt, Hex Head 1/2-13 x 7-1/2"
9	425698	Cover, Fan RH	40	04021-07	Nut, Elastic Stop 1/2-13
10	425697	Cover, Fan LH	41	453010	Yoke, Caster Wheel
11	04041-07	Flatwasher, 3/8-.391 x .938 x .105	42	483466	Bearing
12	483372	Spring, Seat		424636	Spacer, Yoke (not shown)
13	04003-07	Bolt, Carriage 1/4-20 x 1"	43	43736	Spacer, Caster Bearing
14	04017-27	Bolt, Hex Head Flange 3/8-16 x 1"	44	04040-11	Flatwasher, 7/16-.50 x 1.250 x .083
15	427870	Rear Bumper	45	04041-38	Flatwasher, 3/8-.406 x 2.25 x .188
16	424523	Bracket, Anti-Rotation	46	463018	Caster Wheel Assembly w/Yoke
	<b>***425328</b>	<b>Bracket, Anti-Rotation (see below)</b>	47	04003-11	Bolt, Carriage 3/8-16 x 1-1/4"
17	04017-06	Bolt, Hex Head 1/4-20 x 1"	48	483559	Cable, Seat Stop
18	04117-01	Nut, Elastic Stop Flange 5/16-18	49	463171	Control Plate RH (Black)
19	04021-10	Nut, Elastic Stop 5/16-18	50	463136	Weldment, Deck Lift Cover w/Decal
20	04019-04	Nut, Serrated Flange 3/8-16	51	04003-14	Bolt, Carriage 5/16-18 x 1/2"
21	04040-15	Flatwasher, 5/16-.375 x .875 x .083	52	04030-03	Lockwasher, 5/16" Spring
22	463170	Control Plate LH (Black)	53	427868	Bumper, Front
23	04110-01	U-Nut 1/4-20	54	04011-29	Screw, 1/4-20 x 3/4" Shakeproof
24	04001-20	Bolt, Hex Head 3/8-16 x 1-1/2"			
25	424511	Bracket, Switch Mount			
26	424516	Bracket, Tank Mount			

\*\*\* Used on a limited production build of model SFZ52H-26KT in the following serial number range.

R7700001 - R7700289

### SFZ ROLL-OVER PROTECTION SYSTEM

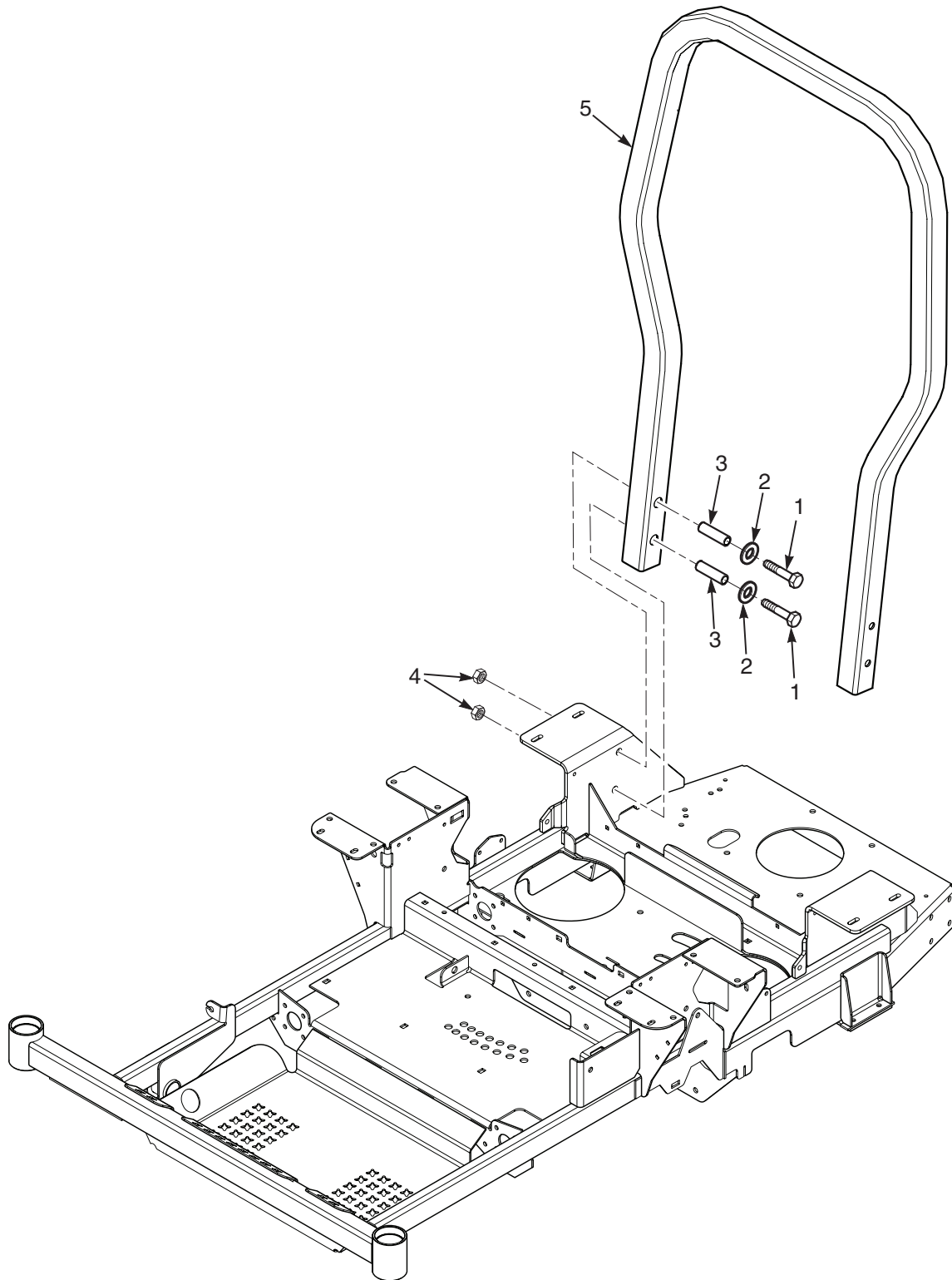



**SFZ ROLL-OVER PROTECTION SYSTEM**

Ref. No.	Part No.	Description
1	04001-184	Bolt, Hex Head 1/213 x 3-1/4" Gr. 8
2	04040-07	Flatwasher, 1/2 - .531 x 1.062 x .095
3	43743	Bushing, SFZ ROPS
4	04117-04	Nut, Flanged Elastic Stop, 1/2-13
5	463113	ROPS, SFZ48H, SFZ52H

### DRIVE SYSTEM COMPONENTS - SFZ48H / 52H

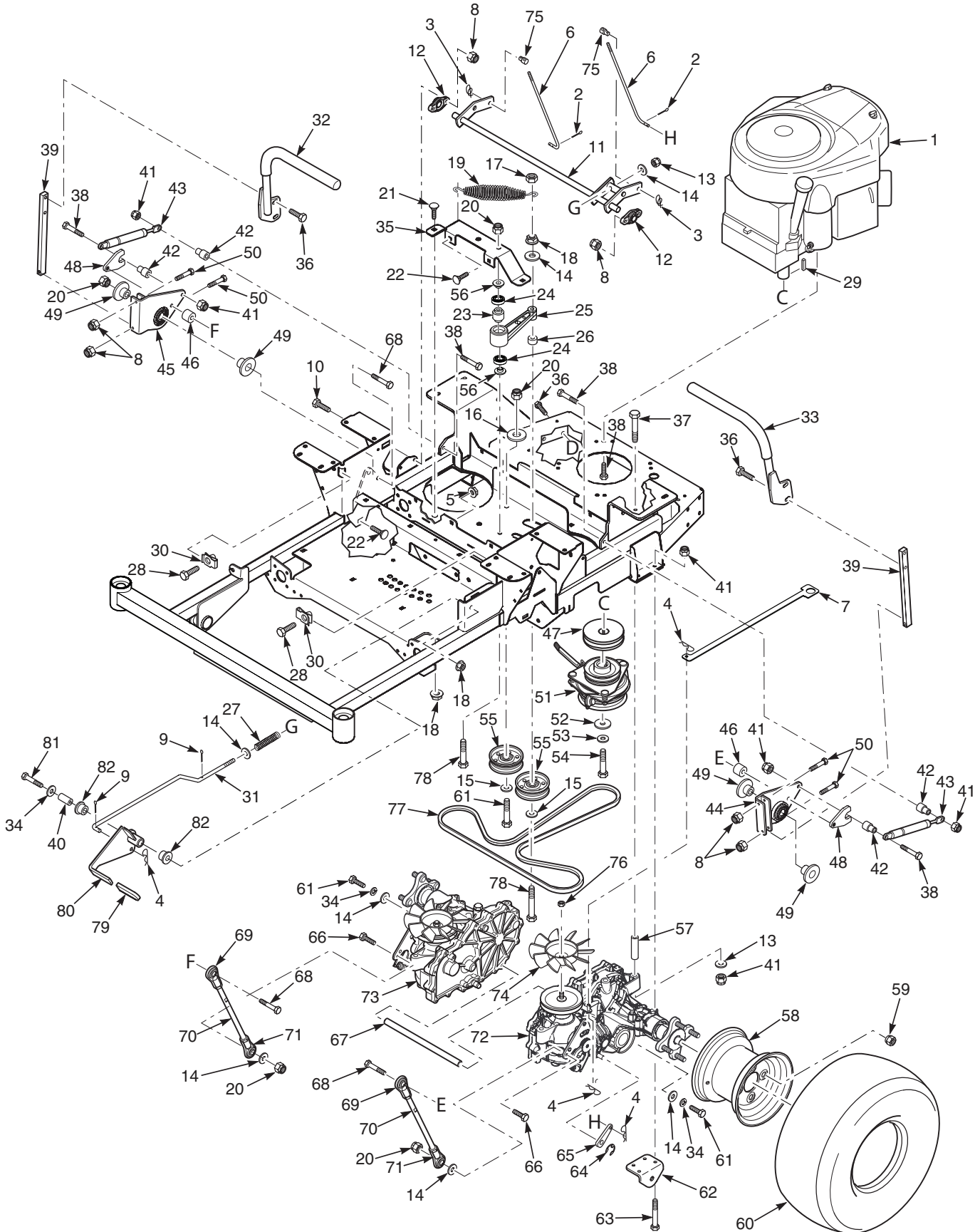

## DRIVE SYSTEM COMPONENTS - SFZ48H / 52H

Ref. No.	Part No.	Description	Ref. No.	Part No.	Description
1	**485972 ***486021 **486903	Engine, Kohler 24KT - 1" Crankshaft <b>Engine, Kohler 26KT - 1.125" (see below)</b> Engine, Kohler 26KT - 1" Crankshaft	49	43719	Spacer, Linkage
2	04061-01	Cotter Pin, 3/32 x 1"	50	04001-04	Bolt, Hex Head 1/4-20 x 1-1/2"
3	04069-01	Pin, Rue Cotter 3/8" Dia.	51	462715	Electric Clutch Assembly
4	04062-02	Hair Pin, .080 x 1.19"		***462228	<b>Electric Clutch Assembly (see below)</b>
5	04019-03	Nut, Serrated Flange 5/16-18		04063-19	Key, 1/4 x 1/4 x 3/4"
6	44165	Rod, Brake Adjustment		***04063-03	<b>Key, 1/4 x 1/4 x 2-1/2" (see below)</b>
7	426591	Lever, Dump Valve	52	04041-28	Flatwasher, 7/16-.469 x 1.75 x .25
8	04117-03	Nut, Elastic Stop Flange 1/4-20		***43832	<b>Spacer, Crankshaft (see below)</b>
9	04062-01	Hairpin, Cotter	53	04030-05	Lockwasher, 7/16" spring
10	04017-06	Bolt, Serrated Flange 1/4-20 x 1"	54	04102-03	Bolt, Hex Head 7/16-20 x 2-1/4" Patch
11	451884	Weldment, Brake Lever		***04102-08	<b>Bolt, Hex Head 7/16-20 x 1-1/2" Patch (see below)</b>
12	483504	Bearing	55	486045	Pulley, 3-1/2" Dia.
13	04040-15	Flatwasher, 5/16-.375 x .875 x .083	56	431049	Spacer, Idler Arm
14	04041-07	Flatwasher, 3/8-.391 x .938 x .105	57	43700	Spacer, Axle
15	04043-04	Flatwasher, 3/8-.391 x .938 x .105 HD	58	486316	Rim w/Valve Stem
16	04041-11	Flatwasher, 3/8-.406 x 1.5 x 7 GA.	59	04028-02	Wheel Nut, 1/2-20
17	04021-05	Nut, Center Lock 3/8-16	60	486315	Wheel Assembly (INCL.58)
18	04019-04	Nut, Serrated Flange 3/8-16		485950	Tire, 20 x 10-10 4-Ply
19	483087	Spring, Transmission Idler	61	04001-31	Bolt, Hex Head 3/8-16 x 2-1/2"
20	04021-09	Nut, Elastic Stop 3/8-16	62	424489	Bracket, Pusharm Link
21	04003-31	Bolt, Carriage 3/8-16 x 3/4"	63	04001-49	Bolt, Hex Head 5/16-18 x 3"
22	04003-12	Bolt, Carriage 5/16-18 x 3/4"	64	HG53019	Clip, Brake Lever (order through Hydro-Gear)
23	431073	Spacer, Bearing	65	HG52639	Lever, Brake (order through Hydro-Gear)
24	48224	Bearing	66	04001-20	Bolt, Hex Head 3/8-16 x 1-1/2"
25	463017	Transmission Idler Arm Assy (Incl. #23 & 24)	67	43701	Spacer, Axle
26	43674	Spacer, Idler Pulley	68	04001-45	Bolt, Hex Head 3/8-16 x 2"
27	483538	Spring, Brake	69	483340	Rod End, 3/8-24 LH
28	04107-01	Bolt, Hex Head 3/8-16 x 1-1/4" Special Lock	70	483337	Linkage, Pump (incl. #69, 71)
29	04063-19	Key, 1/4 x 1/4 x 3/4"	71	483339	Rod End, 3/8-24 RH
30	04110-03	U-Nut, 3/8-16	72	486817	Transaxle Assy., LH (ZK-KCBC-SLKG-3NTX)
31	44157	Rod, Brake Linkage	73	486818	Transaxle Assy., RH (ZK-GCBC-SLKF-2NTX)
32	462434	Handle Bar Assembly RH, w/Grip	74	HG53823	Fan (order through Hydro-Gear)
	484376	Grip	75	43726	Joint, Swivel
33	462433	Handle Bar Assembly LH, w/Grip	76	HG44133	Fan Nut (order through Hydro-Gear)
	484376	Grip	77	483314	Belt, Transmission Drive
34	04041-07	Flatwasher, 3/8-.391 x .938 x .105	78	04001-62	Bolt, Hex Head 3/8-16 x 3-1/4"
35	424476	Support, Idler Arm	79	482102	Grip, Brake Handle
36	04017-27	Bolt, Hex Head Flange 3/8-16 x 1"	80	462010	Brake Handle Assembly
37	04001-95	Bolt, Hex Head 5/16-18 x 5"	81	04001-31	Bolt, Hex Head 3/8-16 x 2-1/2"
38	04001-11	Bolt, Hex Head 5/16-18 x 1-1/2"	82	483453-05	Bearing
	04011-29	Bolt, Self Tapping 1/4-20 x 3/8" (ground)			
39	424498	Bar, Control Lever			
40	43969	Pivot, Brake Lever			
41	04021-10	Nut, Elastic Stop 5/16-18			
42	43602	Spacer, Pump Dampener			
43	484193	Dampener			
44	462127	Control Link, LH			
45	462128	Control Link, RH			
46	43674	Spacer			
47	486010	Pulley, 4-1/2" Dia. 1" Bore			
	***484071	<b>Pulley, 4-1/2" Dia. 1.125" Bore (see below)</b>			
48	424687	Nut, Control Linkage			

\*\* Available through engine manufacturer.

\*\*\* Used on a limited production build of model SFZ52H-26KT in the following serial number range.

R7700001 - R7700289

### EXHAUST AND ELECTRICAL SYSTEM - SFZ48H / 52H

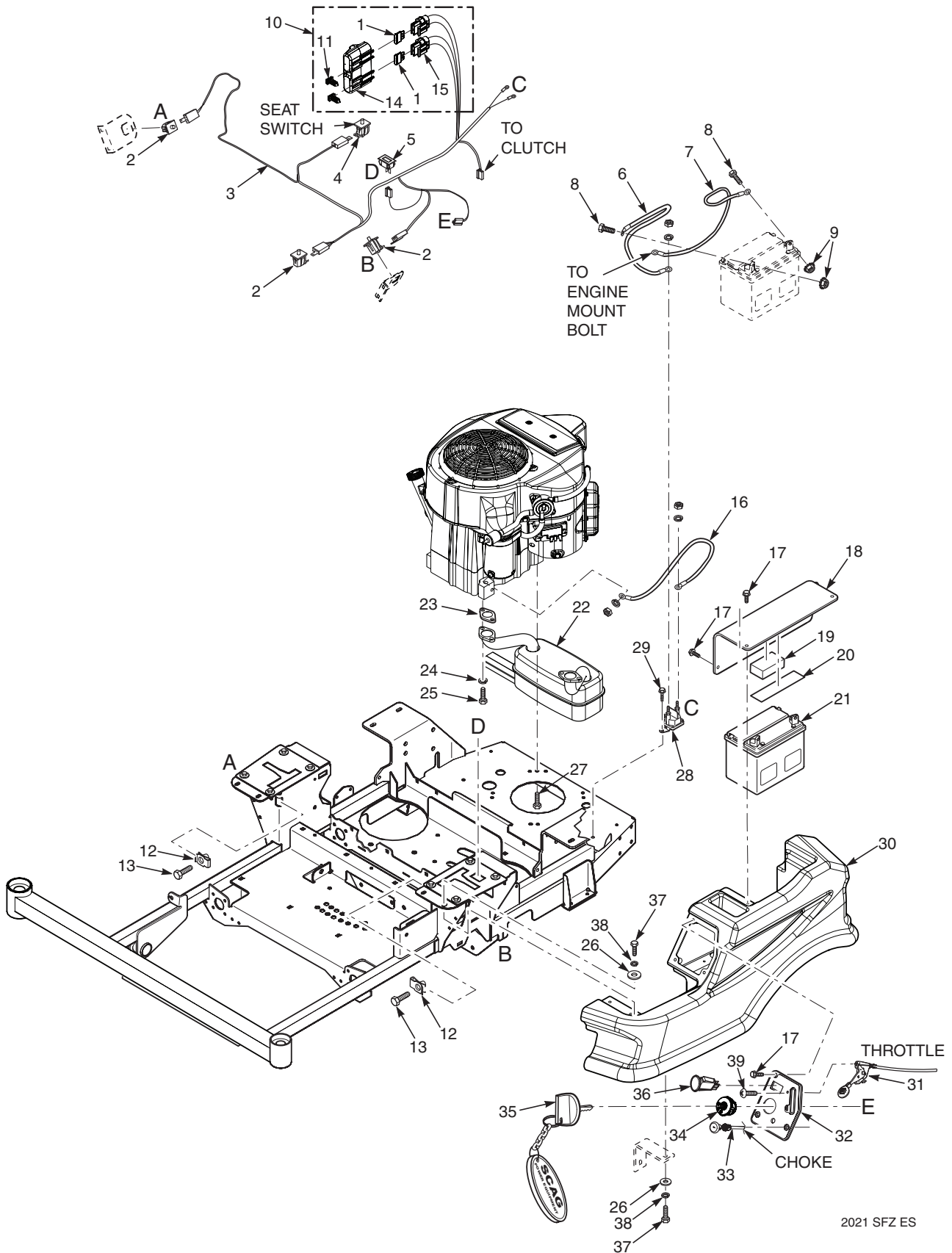

2021 SFZ ES

## EXHAUST AND ELECTRICAL SYSTEM - SFZ48H / 52H

Ref. No.	Part No.	Description
1	48298	Fuse, 20 amp
2	483473	Switch
3	486015	Wire Harness, Main
4	483473	Switch, Seat
5	484565	Hourmeter, Inductive
6	48029-13	Battery Cable, Red 25"
7	48029-11	Battery Cable, Black 27"
8	04001-44	Bolt, Hex Head 1/4-20 x 1/2"
9	04020-02	Nut, 1/4-20
10	483642	Double Fuse Assy. (incl. items 1, 14, 15, 46)
11	482588	Clip, Wire
12	04110-03	U-Nut, 3/8-16
13	04107-03	Bolt, Hex Head 3/8-16 x 1-1/4" Special Lock
14	483571	Cover, Sealed Double
15	483629	Fuse Holder
16	48029-09	Battery Cable, Red 9"
17	04017-04	Bolt, Hex Head 1/4-20 x 1/2" Serr. Flange
18	463319	Battery Cover (incl. items 19 & 20)
19	485506	Pad, Battery Hold Down
20	483508	Rubber Pad
21	*483665	Battery (not avail. through Scag)
22	485336	Muffler, Kohler KT
23	**	Exhaust Gasket
24	04040-15	Lockwasher
25	04001-32	Bolt
26	04030-04	Flatwasher, 5/16-.375 x .875 x .083
27	04011-07	Bolt, Hex Head 3/8-16 x 1-1/4"

Ref. No.	Part No.	Description
28	483278	Solenoid
29	04011-29	Bolt, Self Tapping 1/4-20 x 3/8" Shakeproof
30	463301	Tank Console 48
31	483645	Throttle Cable - Kohler
32	462322	Instrument Panel w/Decal
33	483646	Choke Cable - Kohler
34	483472	Ignition Switch
35	462069	Key Assembly w/Fob
36	485833	PTO Switch
37	04001-08	Bolt, Hex Head 5/16-18 x 3/4"
38	04030-03	Lockwasher, 5/16" Spring
39	04003-43	Bolt, Carriage, 10-24 x .5

\* Not available through Scag Power Equipment. Purchase locally.

\*\* Available through individual engine manufacturer.

FUEL SYSTEM - SFZ48H / 52H

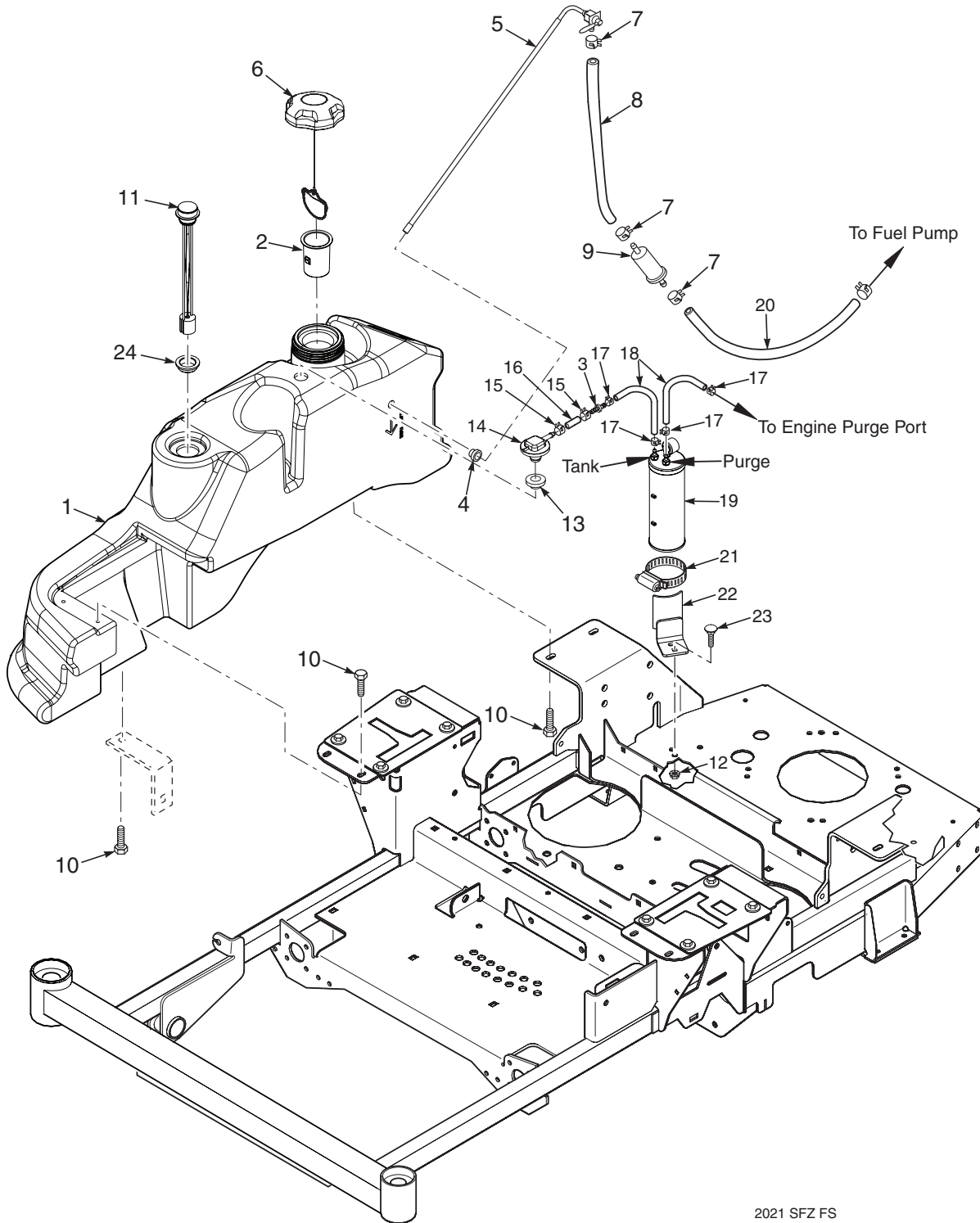

2021 SFZ FS

## FUEL SYSTEM - SFZ48H / 52H

Ref. No.	Part No.	Description
1	463302	Fuel Tank Assembly
2	484279-01	Tube, Fuel Tank Insert
3	484343-01	Mender, 1/4 x 3/16 w/0.02 Hole
4	482571	Bushing, .56 Dia. Viton
5	483555	Fuel Tube Assembly
6	484286	Fuel Cap, Tethered
	484297	Fuel Cap w/Tethered - California Models Only (not shown)
7	48059-01	Clamp, Fuel Hose 1/4"
8	483617	Fuel Hose, 1/4" Non-Perm (order by inch)
9	*	Fuel Filter
10	04017-16	Bolt, Hex Head 5/16-18 x 3/4"
11	485393	Fuel Gauge (requires #24)
12	04019-03	Nut, Serrated Flange 5/16-18
13	484285	Grommet, Viton
14	484333	Remote Vent
15	48059-02	Clamp, Fuel Hose 7/32"
16	484347	Hose, 1/4" Vapor Recovery (order by inch)
17	48059-05	Clamp, Vapor Recovery Hose
18	484345	Hose, 3/16" (order by inch)
19	484342	Carbon Canister
	484366	Dust Filter, Carbon Canister
20	*	Fuel Hose
21	48136-17	Clamp, Hose
22	452233	Bracket Weldment, Kohler Models
23	04003-12	Bolt, Carriage 5/16-18 x 3/4"
24	485394	Grommet, Fuel Gauge

\* = Available through engine manufacturer only.

### FREEDOM TRANSAXLE

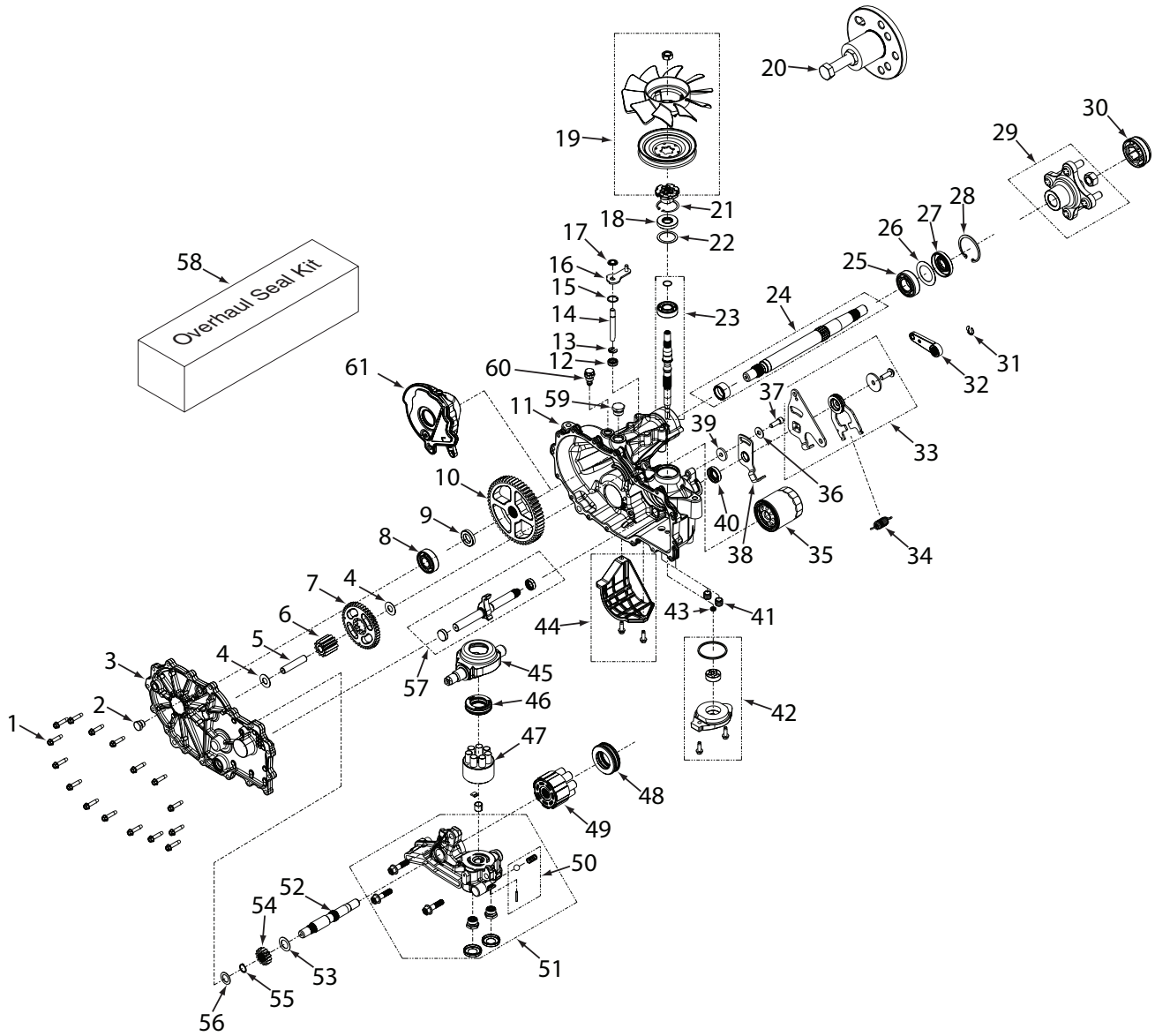



## FREEDOM TRANSAXLE

Ref. No.	Part No.	Description
1	HG53246	Screw, Hex Washer
2	HG54730	Plug, External Hex Vent 9/16-18
3	HG73096	Kit, Side Cover LH
	HG73095	Kit, Side Cover RH
4	HG50132	Washer, Flat, .51 x 1 x .03
5	HG51083	Pin, Jackshaft
6	HG52583	Gear, 11T
7	HG52110	Gear, 45T
8	HG72749	Kit, Bearing
9	HG53336	Spacer, .75 x 1.320 x .257
10	HG52108	Gear, 54T
11	HG73073	Kit, Main Housing LH, Charge, Control
	HG73069	Kit, Main Housing RH Charge, Control
12	HG55232	Seal, Lip, .375 x .75 x .25
13	HG51628	Ring, Retaining External .375
14	HG52136	Rod, Bypass .375 x 2.88
15	HG51627	Ring, Retaining, .750, Internal
16	HG52370	Arm, Bypass (LH)
	HG51910	Arm, Bypass (RH)
17	HG51630	Ring, Retaining, .375 External
18	HG51161	Seal, Lip, 17 x 40 x 7
19	HG72973	Kit, Fan/Pulley
20	HG72320	Kit, Hub Puller
21	HG50329	Ring, Retaining Internal
22	HG50951	Washer, Flat, 1.23 x 1.57 x .04
23	HG73047	Kit, Input Shaft
24	HG71569	Kit, Shaft Axle
25	HG53656	Bearing 25.4 x 52 x 15 Ball (6205R)
26	HG53514	Washer, Flat, 1.355 x 2.035 x .021
27	HG53699	Seal, Lip, TC4, 1 x 2.06 x .38
28	HG50859	Ring, Retaining 2.25 Internal
29	HG71405	Kit, Hub, 4 Bolt
30	HG53088	Cap, Axle
31	HG53019	Ring, Retaining External .438
32	HG53973	Handle, Actuating
33	HG71598	Kit, RTN Bidirectional (LH)
	HG71595	Kit, RTN Bidirectional (RH)
34	HG51605	Spring, Extension
35	HG52114	Filter, Spin-on 2.6 x 3
36	HG44130	Washer, Flat, .34 x .88 x .06
37	HG51616	Bolt, 5/16-24 x 7/8" (w/patch)
38	HG51946	Arm, Return Left
	HG51945	Arm, Neutral Right
39	HG54315	Spacer, .32 ID x 1.005 OD x .1495 Thk
40	HG51140	Seal, Lip, 18 x 32 x 7
41	HG54501	Tube, Charge Triple O-ring

Ref. No.	Part No.	Description
42	HG72274	Kit, Charge
43	HG72291	Kit, Gerotor Seal
44	HG71854	Kit, Filter Guard (LH)
	HG73041	Kit, Filter Guard (RH)
45	HG51048	Swashplate, Trunnion
46	HG50551	Bearing, Thrust 30 x 52 x 13
47	HG70723	Kit,Block 7 Piston
48	HG51462	Bearing, Thrust 35 x 62 x 18
49	HG72882	Kit, 16cc Cylinder Block Assembly (steam treated)
50	HG71436	Kit, Charge Relief
51	HG72515	Kit, Center Section, LH Charge
	HG72516	Kit, Center Section, RH Charge
52	HG52150	Shaft, Motor
53	HG51069	Washer, Flat, .71 x 1.16 x .04
54	HG52109	Gear, 14T
55	HG44145	Retaining Ring, Motor Shaft
56	HG44371	Washer, Flat, .63 x 1 x .05
57	HG73119	Kit, Outboard, RH Rot B / LH Rot A (LH)
	HG73118	Kit, Outboard, RH Rot A / LH Rot B (RH)
58	HG73107	Kit, Seal (ZT-2800)
59	HG54974	Plug, 3/4-16
60	HG55380	Fitting 9/16 - 18, Breather
61	HG55072	Expansion Tank, Internal LH
	HG55071	Expansion Tank, Internal RH
*	HG50928	Tube, Sealant





\* Item not shown

### REPLACEMENT DECALS AND INFORMATION PLATES

**WARNING**  
 **INSTALL BELT COVER BEFORE OPERATING MACHINE**  
 READ OPERATOR'S MANUAL 483402 1

**WARNING**  
**DO NOT OPERATE WITHOUT DISCHARGE CHUTE, MULCHING KIT, OR ENTIRE GRASS CATCHER INSTALLED** 483405 2

**IMPORTANT**  
 Operation on slopes can be hazardous.  
 This machine was originally equipped with a Rollover Protection Device with a Roll Bar and Seat Belt.  
 See your dealer if either is missing or damaged.  
 483425 3

**DANGER**  
  
  
**SPINNING BLADES**  
  
**KEEP CLEAR**  
  
**BLADE CONTACT & THROWN OBJECTS CAN INJURE** 4

**FORWARD**  
 **F**  
**REVERSE**  
**R**  5

**WARNING**  
 Replace seat only with Scag approved seat with seat mounting provisions and Scag approved seat belts.  
 Failure to follow these directions could result in injury or death in the event of a rollover.  
 483411 6

**WARNING**  
**ROTATING BLADES AND BELTS**  
 \* Keep hands, feet & clothing clear  
 \* Keep all guards in place  
 \* Shut off engine & disengage blade clutch before servicing  
 \* Use caution in directing discharge  
 \* Read instruction manual before operating  
**DO NOT OPERATE UNLESS GRASS CATCHER, MULCHING KIT OR DISCHARGE CHUTE IS INSTALLED** 483406 8

**52 HERO**  
 COMMERCIAL  GRADE 7

**IMPORTANT ADJUSTMENT PROCEDURES**  
 READ OPERATORS MANUAL FOR MORE DETAILS  
 Check tire pressure - Drive tires-8 psi -  
 - Caster tires-25 psi

**FREE WHEEL OPERATION**  
 To move machine without running engine, pull both dump valve rods up and back (located at rear of machine) and latch. Pull rods forward and latch into front slot to operate mower.

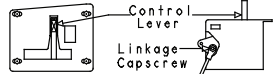
**NEUTRAL ADJUSTMENT**  
  
 Control Lever  
 Linkage Capscrew  
 To re-set neutral, have engine off and control levers in neutral. Loosen upper linkage capscrew. Allow transmission to position linkage rod and tighten upper capscrew. Repeat for opposite side. If wheels still creep after adjustment, see an authorized Scag dealer.

**TRACKING ADJUSTMENT**  
  
 Control Lever  
 Stop Bolt  
 If machine pulls to right, adjust LH control stop bolt CW (inward) to slow left wheel down. Adjust RH control stop bolt CW (inward) to slow right wheel down.

**HYDRAULIC FLUID LEVEL**  
 Check hydraulic fluid level while fluid is cool. Fluid level should be in sight window. Fill with 20W50 motor oil only.

**IMPORTANT**  
 Do not overfill. Room for hot fluid expansion must be allowed or resulting expansion may cause leaks in the system

9

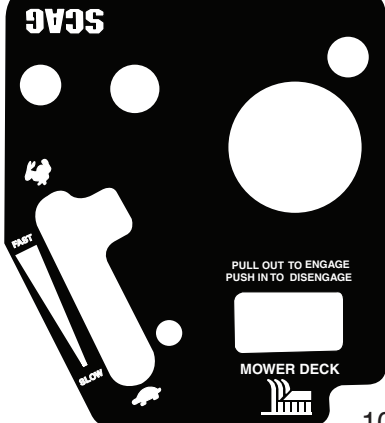
**SCAG**  
  
 FAST  
 SLOW  
 MOWER DECK  
 PULL OUT TO ENGAGE  
 PUSH IN TO DISENGAGE  
 10

**SCAG**  
 11

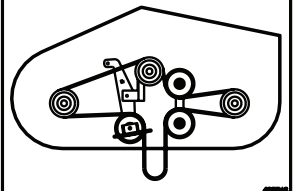
  
 12

## Section 8

### REPLACEMENT DECALS AND INFORMATION PLATES

Ref. No.	Part No.	Description
1	483402	Decal, Belt Cover
2	483405	Decal, Warning
3	486304	Decal, ROPS
4	483505	Decal, Spinning Blades
5	481568	Decal, Traction Control
6	483633	Decal, Seat Replacement
7	486794	Decal, 48H Commercial
	486795	Decal, 52H Commercial
8	483406	Decal, Knives
9	486846	Decal, Adjustment SFZ
10	483499	Decal, Instrument Panel - SFZ48H & SFZ 52H
11	486831	Decal, Scag RH Fuel Tank
	486830	Decal, Scag LH Fuel Tank
12	485516	Decal, Belt Routing
13	486313	Decal, Cutting Height
14	486308	Decal, Freedom Z (Fuel Tank)
15	486309	Decal, Scag Freedom Z (Fuel Tank)
*	483900	Decal, Warning Spark Arrestor (California only)
*	462155	Spanish Decal Kit - SFZ (not shown)
*	01411	DVD Video, Tips for Safe Operation of Your Scag Zero-Turn Mower (not shown)

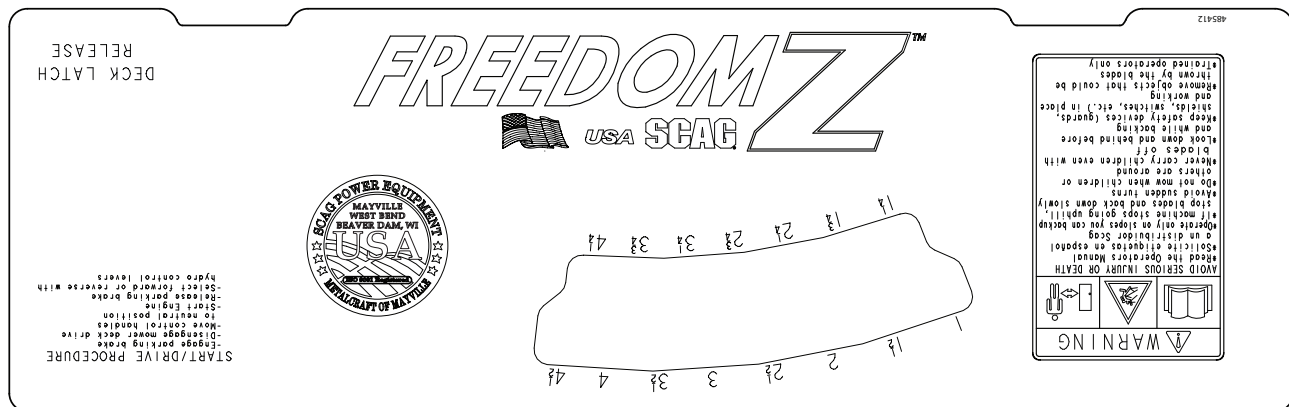

13

14

15

### ELECTRICAL SCHEMATIC

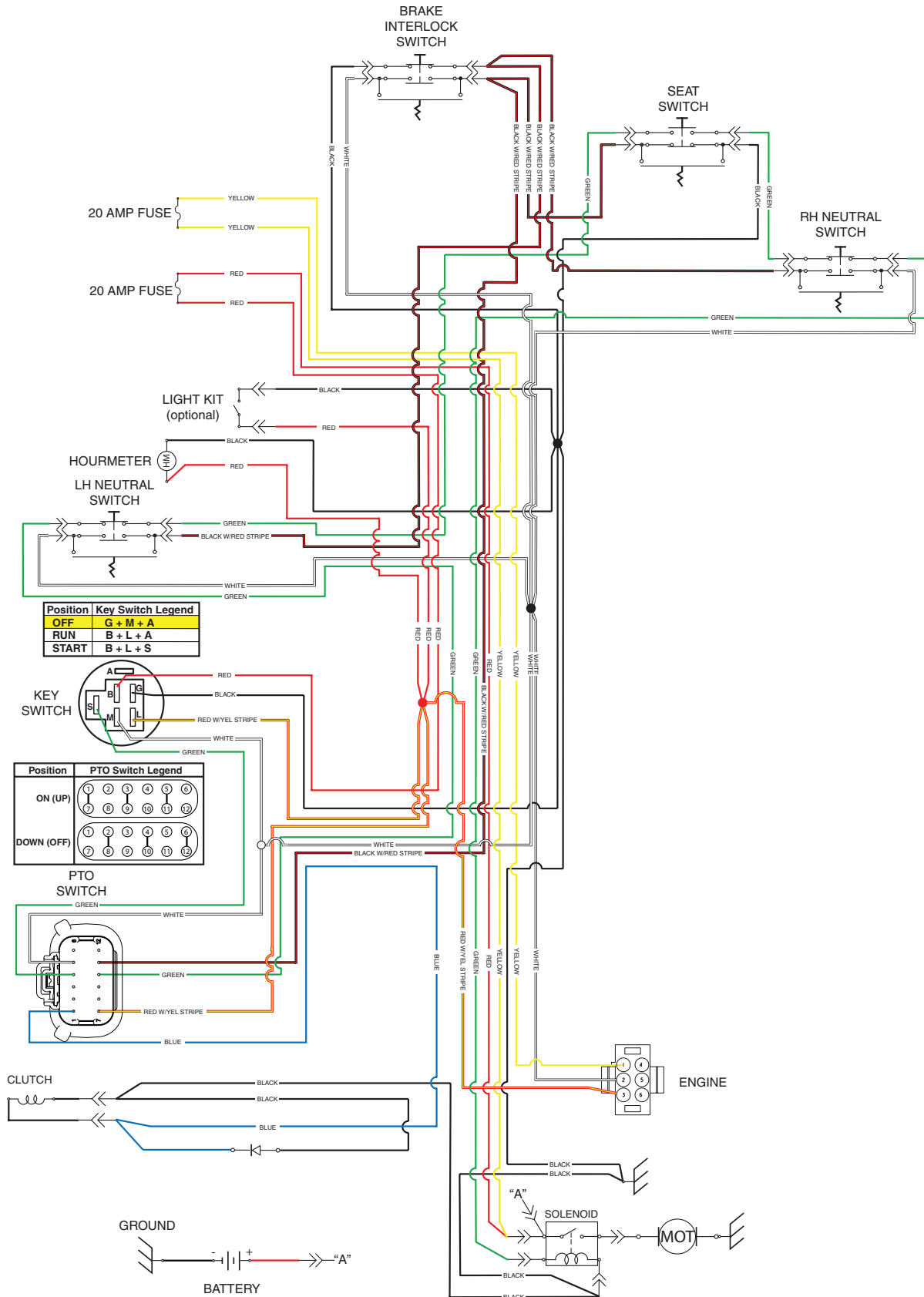

# LIMITED WARRANTY - SFZ

---

Any part of the Scag commercial mower manufactured by Scag Power Equipment and found, in the reasonable judgment of Scag, to be defective in materials or workmanship, will be repaired or replaced by an Authorized Scag Service Dealer without charge for parts and labor during the periods specified below. This warranty is limited to the original purchaser provided the product was purchased from an Authorized Scag Power Equipment Dealer and is not transferable. Proof of purchase will be required by the dealer to substantiate any warranty claims. All warranty work must be performed by an Authorized Scag Service Dealer.

This warranty is limited to the following specified periods from the date of the original retail purchase for defects in materials or workmanship:

- Wear items including drive belts, blades, hydraulic hoses and tires are warranted for ninety (90) days.
- Batteries are covered for ninety (90) days.
- Frame and structural components including the oil reservoir are warranted for one (1) year (parts and labor) for commercial use or three (3) years / 500 hours (whichever comes first) (Parts and labor) for non-commercial use.
- Cutter decks are warranted against cracking for a period of one (1) years. (parts and labor) for commercial use or three (3) years / 500 hours (whichever comes first) (First and second year of the warranty covers parts and labor. The third year covers parts or labor to repair) for non-commercial use. The repair or replacement of the cutter deck will be at the option of Scag Power Equipment. We reserve the right to request components for evaluation. This warranty does not cover any mower that has been subject to misuse, neglect, negligence, or accident, or that has been operated in any way contrary to the operating instructions as specified in the Operator's Manual.
- Engines and electric starters are covered by the engine manufacturer's warranty period.
- Major drive system components are warranted for one (1) year (parts and labor) for commercial use or three (3) year / 500 hour (whichever comes first) (Parts and labor) for non-commercial use by Scag Power Equipment. (commercial and non-commercial warranty excludes fittings, hoses, drive belts). The repair or replacement of the hydraulic axles will be at the option of Scag Power Equipment. This warranty does not cover any mower that has been subject to misuse, neglect, negligence, or accident, or that has been operated in any way contrary to the operating instructions as specified in the Operator's Manual.
- Electric clutches have a Limited Warranty for one (1) year (parts and labor) for commercial use or three (3) year / 500 hours (whichever comes first) (Parts and labor) for non-commercial use.
- Spindle assemblies have a Limited Warranty for one (1) year (parts and labor) for commercial use or three years / 500 hours (whichever comes first) (First and second year of the warranty covers parts and labor. The third year covers parts only) for non-commercial use.
- Any Scag product used for rental purposes is covered by a 90 day warranty.

The Scag mower, including any defective part must be returned to an Authorized Scag Service Dealer within the warranty period. The expense of delivering the mower to the dealer for warranty work and the expense of returning it to the owner after repair will be paid for by the owner. Scag's responsibility is limited to making the required repairs and no claim of breach of warranty shall be cause for cancellation or rescission of the contract of sale of any Scag mower. "Non-Commercial" use is defined as a single property owner, where the single property is the residence of the owner of the mower. If the mower is cutting more than the owners single property, it is deemed commercial use and the "non-commercial" warranty does not apply. Scag Power Equipment reserves the right to deny and / or void the non-commercial warranty if it believes it to be in commercial use.

**This warranty does not cover any mower that has been subject to misuse, neglect, negligence, or accident, or that has been operated in any way contrary to the operating instructions as specified in the Operator's Manual.** The warranty does not apply to any damage to the mower that is the result of improper maintenance, or to any mower or parts that have not been assembled or installed as specified in the Operator's Manual and Assembly Manual. The warranty does not cover any mower that has been altered or modified, changing performance or durability. In addition, the warranty does not extend to repairs made necessary by normal wear, or by the use of parts or accessories which, in the reasonable judgment of Scag, are either incompatible with the Scag mower or adversely affect its operation, performance or durability.

**Scag Power Equipment reserves the right to change or improve the design of any mower without assuming any obligation to modify any mower previously manufactured.** All other implied warranties are limited in duration to the one (1) year warranty commercial use, three (3) years / 500 hour for non-commercial use or ninety (90) days for mowers used for rental purpose. Accordingly, any such implied warranties including merchantability, fitness for a particular purpose, or otherwise, are disclaimed in their entirety after the expiration of the appropriate one year, three year / 500 hour or ninety day warranty period. Scag's obligation under this warranty is strictly and exclusively limited to the repair or replacement of defective parts and Scag does not assume or authorize anyone to assume for them any other obligation. Some states do not allow limitations on how long an implied warranty lasts, so the above limitation may not apply to you.

Scag assumes no responsibility for incidental, consequential or other damages including, but not limited to, expense for gasoline, expense of delivering the mower to an Authorized Scag Service Dealer and expense of returning it to the owner, mechanic's travel time, telephone or telegram charges, rental of a like product during the time warranty repairs are being performed, travel, loss or damage to personal property, loss of revenue, loss of use of the mower, loss of time or inconvenience. Some states do not allow the exclusion or limitation of incidental or consequential damages, so the above limitation or exclusion may not apply to you. This warranty gives you specific legal rights, and you may also have other rights which vary from state to state.

