

SCAG[®]

POWER EQUIPMENT

OPERATOR'S MANUAL

PATRIOT

 USA **SCAG**™



Models: **SPZ52H-22FX**
SPZ52H-23CV
SPZ61H-23FX
SPZ61H-25CV

Congratulations on owning a Scag mower! This manual contains the operating instructions and safety information for your Scag mower. Reading this manual can provide you with assistance in maintenance and adjustment procedures to keep your mower performing to maximum efficiency. The specific models that this book covers are listed on the inside cover. Before operating your machine, please read all the information enclosed.



WARNING

FAILURE TO FOLLOW SAFE OPERATING PRACTICES MAY RESULT IN SERIOUS INJURY OR DEATH.

- Read this manual completely as well as other manuals that came with your mower.
- DO NOT operate on steep slopes. To check a slope, attempt to back up it (with the cutter deck down). If the machine can back up the slope without the wheels slipping, reduce speed and use extreme caution.
- Under no circumstances should the machine be operated on slopes greater than 15 degrees. ALWAYS FOLLOW OSHA APPROVED OPERATION.
- Stay two cut widths away from slopes, drop offs, ditches and retaining walls.
- DO NOT mow on wet grass. Wet grass reduces traction and steering control.
- Keep all shields in place, especially the grass discharge chute.
- Before performing any maintenance or service, stop the machine and remove the spark plug wire and ignition key.
- If a mechanism becomes clogged, stop the engine before cleaning.
- Keep hands, feet and clothing away from power-driven parts.
- Keep others off the mower (only one person at a time).

REMEMBER - YOUR MOWER IS ONLY AS SAFE AS THE OPERATOR!

HAZARD CONTROL AND ACCIDENT PREVENTION ARE DEPENDENT UPON THE AWARENESS, CONCERN, PRUDENCE, AND PROPER TRAINING OF THE PERSONNEL INVOLVED IN THE OPERATION, TRANSPORT, MAINTENANCE, AND STORAGE OF THE EQUIPMENT.

This manual covers the operating instructions and illustrated parts list for:

SPZ52H-22FX	with a serial number of	R7800001 to R7899999
SPZ52H-23CV	with a serial number of	R7900001 to R7999999
SPZ61H-23FX	with a serial number of	R8000001 to R8099999
SPZ61H-25CV	with a serial number of	R8100001 to R8199999

Always use the entire serial number listed on the serial number tag when referring to this product.

Table of Contents

SECTION 1 - GENERAL INFORMATION.....	1
1.1 INTRODUCTION.....	1
1.2 DIRECTION REFERENCE	1
1.3 SERVICING THE ENGINE AND DRIVE TRAIN COMPONENTS.....	1
1.4 SYMBOLS	2
SECTION 2 - SAFETY INFORMATION	3
2.1 INTRODUCTION.....	3
2.2 SIGNAL WORDS	3
2.3 BEFORE OPERATION CONSIDERATIONS.....	3
2.4 TESTING THE SAFETY INTERLOCK SYSTEM	4
2.5 OPERATION CONSIDERATIONS.....	5
2.6 ROLL-OVER PROTECTION SYSTEM	6
2.7 MAINTENANCE CONSIDERATIONS & STORAGE	8
2.8 USING A SPARK ARRESTOR.....	9
2.9 SPARK IGNITION SYSTEM	9
2.10 SAFETY AND INSTRUCTIONAL DECALS	10
SECTION 3 - SPECIFICATIONS	11
3.1 ENGINE	11
3.2 ELECTRICAL	11
3.3 MOWER	11
3.4 CUTTER DECK	12
3.5 HYDRAULIC SYSTEM	12
3.6 WEIGHTS AND DIMENSIONS	12
3.7 PRODUCTIVITY	12
SECTION 4 - OPERATING INSTRUCTIONS	13
4.1 CONTROLS AND INSTRUMENT IDENTIFICATION	13
4.2 SAFETY INTERLOCK SYSTEM	15
4.3 TESTING THE SAFETY INTERLOCK SYSTEM	15
4.4 INITIAL RUN-IN PROCEDURES.....	15
4.5 STARTING THE ENGINE	16
4.6 GROUND TRAVEL AND STEERING	16
4.7 ENGAGING THE DECK DRIVE (CUTTER BLADES).....	17
4.8 HILLSIDE OPERATION.....	18
4.9 PARKING THE MOWER.....	18
4.10 AFTER OPERATION	18
4.11 REMOVING CLOGGED MATERIAL	19
4.12 MOVING MOWER WITH ENGINE STOPPED	19
4.13 RECOMMENDATIONS FOR MOWING	19
4.14 ADJUSTING CUTTING HEIGHT.....	19
4.15 TOWING (OPTIONAL HITCH ACCESSORY).....	20

SECTION 5 - TROUBLESHOOTING CUTTING CONDITIONS	21
SECTION 6 - ADJUSTMENTS	24
6.1 PARKING BRAKE ADJUSTMENT	24
6.2 TRAVEL ADJUSTMENTS	25
6.3 THROTTLE CONTROL AND CHOKE ADJUSTMENTS	26
6.4 BELT ADJUSTMENT	26
6.5 BELT ALIGNMENT.....	26
6.6 CUTTER DECK ADJUSTMENTS	27
6.7 ELECTRIC CLUTCH ADJUSTMENT.....	29
SECTION 7 - MAINTENANCE.....	30
7.1 MAINTENANCE CHART - RECOMMENDED SERVICE INTERVALS	30
7.2 HYDRAULIC SYSTEM	31
7.3 ENGINE OIL	32
7.4 ENGINE FUEL SYSTEM	33
7.5 ENGINE AIR CLEANER.....	34
7.6 BATTERY.....	34
7.7 DRIVE BELTS.....	35
7.8 CUTTER BLADES.....	36
7.9 TIRES.....	37
7.10 BODY, DECK, AND UPHOLSTERY	37
7.11 CASTER PIVOT GREASE PROCEDURE.....	37
SECTION 8 - ILLUSTRATED PARTS LIST	38
8.1 SCAG APPROVED ATTACHMENTS AND ACCESSORIES.....	38
NOTES.....	39
52H CUTTER DECK.....	40
61H CUTTER DECK.....	42
CUTTER DECK CONTROLS - SPZ52H	44
CUTTER DECK CONTROLS - SPZ61H	46
SHEET METAL COMPONENTS - SPZ	48
SPZ SUSPENSION SEAT	50
NOTES.....	51
BRAKE COMPONENTS - SPZ	52
SPZ ROLL-OVER PROTECTION SYSTEM	54
DRIVE SYSTEM COMPONENTS - SPZ52 & SPZ61.....	56
EXHAUST AND ELECTRICAL SYSTEM - SPZ	58
SPZ FUEL SYSTEM.....	60
ZT-3100 HYDRAULIC AXLE ASSEMBLY - SPZ52.....	62
ZT-3400 HYDRAULIC AXLE ASSEMBLY - SPZ61.....	64
REPLACEMENT DECALS AND INFORMATION PLATES	66
SPZ - ELECTRICAL SCHEMATIC	68
LIMITED WARRANTY - SPZ.....	INSIDE BACK COVER

GENERAL INFORMATION

1.1 INTRODUCTION

Your mower was built to the highest standards in the industry. However, the prolonged life and maximum efficiency of your mower depends on you following the operating, maintenance and adjustment instructions in this manual.

If additional information or service is needed, contact your Scag Power Equipment Dealer.

We encourage you to contact your dealer for repairs. All Scag dealers are informed of the latest methods to service this equipment and provide prompt and efficient service in the field or at their service shop. They carry a full line of Scag service parts.

THE REPLACEMENT OF ANY PART ON THIS PRODUCT BY OTHER THAN THE MANUFACTURER'S AUTHORIZED REPLACEMENT PART MAY ADVERSELY AFFECT THE PERFORMANCE, DURABILITY OR SAFETY OF THIS PRODUCT.

USE OF OTHER THAN ORIGINAL SCAG REPLACEMENT PARTS WILL VOID THE WARRANTY.

When ordering parts, always give the model and serial number of your mower. The serial number plate is located where shown in Figure 1-1.

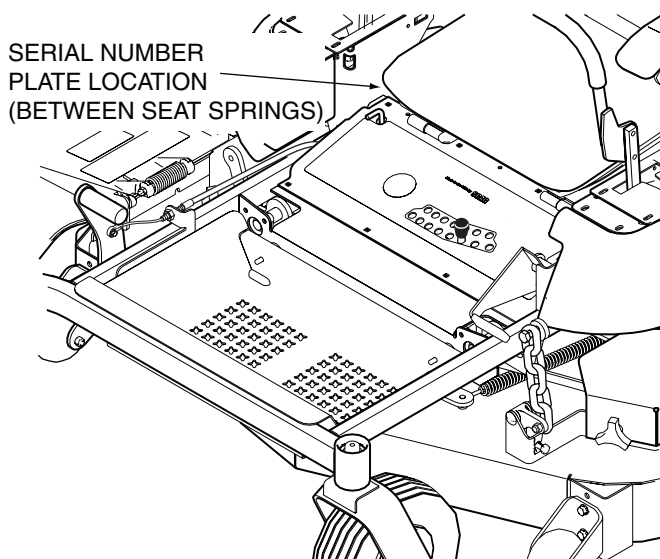

Figure 1-1. Mower Serial Number Plate Location

USE ONLY SCAG APPROVED ATTACHMENTS AND ACCESSORIES.

Attachments and accessories manufactured by companies other than Scag Power Equipment are not approved for use on this machine. See Section 8, Paragraph 8-1.

WARNING

For pictorial clarity, some illustrations and figures in this manual may show shields, guards or plates open or removed. Under no circumstances should your mower be operated without these devices in place.

All information is based upon product information available at the time of approval for printing. Scag Power Equipment reserves the right to make changes at any time without notice and without incurring any obligation.















1.2 DIRECTION REFERENCE

The “Right” and “Left”, “Front” and “Rear” of the machine are referenced from the operator’s right and left when seated in the normal operating position and facing the forward travel direction.

1.3 SERVICING THE ENGINE AND DRIVE TRAIN COMPONENTS

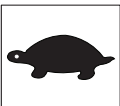
The detail servicing and repair of the engine, hydraulic pumps and gearboxes are not covered in this manual; only routine maintenance and general service instructions are provided. For service of these components during the limited warranty period, it is important to contact your Scag dealer or find a local authorized servicing agent of the component manufacturer. Any unauthorized work done on these components during the warranty period may void your warranty.

1.4 SYMBOLS

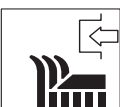
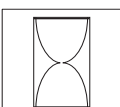
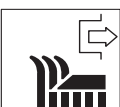
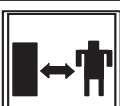
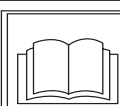
SYMBOL	DESCRIPTION	SYMBOL	DESCRIPTION
	Choke		Transmission
	Parking Brake	 48071B	Spinning Blade
	On/Start		Spring Tension on Idler
	Off/Stop		Oil
	Falling Hazard		Thrown Object Hazard
	Fast		Slow
	Continuously Variable - Linear		Cutting Element - Basic Symbol
 481039S	Pinch Point		Cutting Element - Engage
	Hour meter/Elapsed Operating Hours		Cutting Element - Disengage
	Keep Bystanders Away		Read Operator's Manual

SAFETY INFORMATION

2.1 INTRODUCTION

Your mower is only as safe as the operator. Carelessness or operator error may result in serious bodily injury or death. Hazard control and accident prevention are dependent upon the awareness, concern, prudence, and proper training of the personnel involved in the operation, transport, maintenance and storage of the equipment. Make sure every operator is properly trained and thoroughly familiar with all of the controls before operating the mower. The owner/user can prevent and is responsible for accidents or injuries occurring to themselves, other people or property.

READ THIS OPERATOR'S MANUAL AND WATCH THE TIPS FOR SAFE OPERATION OF YOUR SCAG ZERO-TURN MOWER VIDEO BEFORE ATTEMPTING TO START YOUR MOWER..

A replacement manual is available from your authorized Scag Service Dealer or by contacting Scag Power Equipment, Service Department at P.O. Box 152, Mayville, WI 53050 or contact us via the Internet at www.scag.com. The manual for this machine can be downloaded by using the model and serial number or use the contact form to make your request. Please indicate the complete model and serial number of your Scag product when requesting replacement manuals.

2.2 SIGNAL WORDS



This symbol means **“Attention! Become Alert! Your Safety is Involved!”** The symbol is used with the following signal words to attract your attention to safety messages found on the decals on the machine and throughout this manual. The message that follows the symbol contains important information about safety. To avoid injury and possible death, carefully read the message! Be sure to fully understand the causes of possible injury or death.

SIGNAL WORD:

It is a distinctive word found on the safety decals on the machine and throughout this manual that alerts the viewer to the existence and relative degree of the hazard.



DANGER

The signal word “DANGER” denotes that an extremely hazardous situation exists on or near the machine that could result in high probability of death or irreparable injury if proper precautions are not taken.



WARNING

The signal word “WARNING” denotes that a hazard exists on or near the machine that can result in injury or death if proper precautions are not taken.



CAUTION

The signal word “CAUTION” is a reminder of safety practices on or near the machine that could result in personal injury if proper precautions are not taken.

Your safety and the safety of others depends significantly upon your knowledge and understanding of all correct operating practices and procedures of this machine.

2.3 BEFORE OPERATION CONSIDERATIONS



WARNING

Check all hydraulic connections for tightness. Inspect all hydraulic hoses and / or lines to insure they are in good condition before operating.

1. NEVER allow children to operate this riding mower. Do not allow adults to operate this machine without proper instructions.
2. Do not mow when children and/or others are present. Keep children out of the mowing area and in the watchful care of a responsible adult other than the operator. Be alert and turn machine off if a child enters the area.

- DO NOT allow children to ride or play on the machine, it is not a toy.
- Clear the area to be mowed of objects that could be picked up and thrown by the cutter blades.
- DO NOT carry passengers.
- DO NOT operate the machine under the influence of alcohol or drugs.
- If the operator(s) or mechanic(s) cannot read English, it is the owner's responsibility to explain this material to them.
- DO NOT wear loose fitting clothing. Loose clothing, jewelry or long hair could get tangled in moving parts. Do not operate the machine wearing shorts; always wear adequate protective clothing including long pants. Wearing safety glasses, safety shoes and a helmet is advisable and is required by some local ordinances and insurance regulations.



WARNING

Always wear hearing protection. Operating this machine over prolonged periods of time can cause loss of hearing.

- Keep the machine and attachments in good operating condition. Keep all shields and safety devices in place. If a shield, safety device or decal is defective or damaged, repair or replace it before operating the machine.
- Fuel is flammable; handle it with care. Fill the fuel tank outdoors. Never fill it indoors. Use a funnel or spout to prevent spillage. Clean up any spillage before starting the engine.
- DO NOT add fuel to a running or hot engine. Allow the engine to cool for several minutes before adding fuel. Never fuel indoors or inside enclosed trailers.
- Keep flammable objects (cigarettes, matches, etc.), open flames and sparks away from the fuel tank and fuel container. Use only approved containers.
- See Section 7.4 ENGINE FUEL SYSTEM for fueling procedure.
- Equipment must comply with the latest requirements per SAE J137 and/or ANSI/ASAE S279 when driven on public roads.

- NOTE -

If the mower is driven on public roads, it must comply with state and local ordinances as well as SAE J137 and/or ANSI/ASAE S279 requirements. Contact your local authorities for regulations and equipment requirements.

- Do not operate without the side discharge chute installed and in the down position or with an optional grass catcher or mulch plate completely installed.
- Check the blade mounting bolts at frequent intervals for proper tightness.
- Make sure all hydraulic fluid connections are tight and all hydraulic hoses and lines are in good condition before starting the machine.
- Be sure the interlock switches are functioning correctly.

2.4 TESTING THE SAFETY INTERLOCK SYSTEM

The safety interlock system should be tested each time before using the machine. If the safety interlock system does not operate as described below, contact your local Authorized Scag Power Equipment Dealer immediately to have the safety interlock system repaired.



WARNING

This machine is equipped with an interlock system intended to protect the operator and others from injury. This is accomplished by preventing the engine from starting unless the deck drive is disengaged, the steering control levers are in the neutral position and the operator is in the seat. The system shuts off the engine if the operator leaves the seat with the deck drive engaged and/or the steering control levers are not in the neutral position and the parking brake is not engaged. Never operate equipment with the interlock system disconnected or malfunctioning.

- Sit in the seat in the operating position, engage the parking brake, place the steering control levers in the neutral lock position, and engage the PTO switch to the ON (up) position. Try to start the engine; the engine should not start

Section 2

- Sit in the seat in the operating position, engage the parking brake, move the PTO switch to the OFF (down) position, move either of the steering control handles out of the neutral lock position. Try to start the engine; the engine should not start. Repeat for the other steering control lever.

-NOTE-

- All SPZ models will start with the parking brake engaged or disengaged. For all test procedures listed below, the engine should be started with the parking brake engaged unless specified otherwise.
- Sit in the seat in the operating position, engage the parking brake, place the steering control levers in the neutral lock position, move the PTO switch to the OFF (down) position, and start the engine. With the engine running, release the parking brake and rise slightly off of the seat. The engine should shut off.
- Sit in the seat in the operating position, engage the parking brake, place the steering control levers in the neutral lock position, move the PTO switch to the OFF (down) position, and start the engine. With the engine running, engage the PTO switch to the ON (up) position, and rise slightly off of the seat. The engine should shut off.
- Sit in the seat in the operating position, engage the parking brake, place the steering control levers in the neutral lock position, move the PTO switch to the OFF (down) position, and start the engine. With the engine running, move either steering control lever out of the neutral lock position. The engine should shut off. Repeat for the other steering control lever.

2.5 OPERATION CONSIDERATIONS

- Know the function of all controls and how to stop quickly.

WARNING

DO NOT operate on steep slopes. To check a slope, attempt to back up it (with the cutter deck down). If the machine can back up the slope without the wheels slipping, reduce speed and use extreme caution. Under no circumstances should the machine be operated on slopes greater than 15 degrees. See Figure 2-4, Page 7 to determine approximate slope of area to be mowed. ALWAYS FOLLOW OSHA APPROVED OPERATION.

- Reduce speed and exercise extreme caution on slopes and sharp turns to prevent tipping or loss of control. Be especially cautious when changing directions on slopes.
- Stay two cut widths away from slopes, drop offs, ditches and retaining walls.
- To prevent tipping or loss of control, start and stop smoothly, avoid unnecessary turns and travel at reduced speed. Use caution when operating the mower on an incline with the optional grass catcher installed.
- Immediately apply the parking brake if you lose steering control while operating. Inspect the machine and correct the problem before continuing to operate.
- When using any attachment, never direct the discharge of material toward bystanders or allow anyone near the machine while in operation.
- Before attempting to start the engine, with the operator in the seat, disengage power to the cutter deck, place the steering control levers in the neutral position and engage the parking brake.
- If the mower discharge ever plugs, shut off the engine, remove the ignition key, and wait for all movement to stop before removing the obstruction.

WARNING

DO NOT use your hand to dislodge the clogged discharge chute. Use a stick or other device to remove clogged material after the engine has stopped running and the blades have stopped turning.

- Be alert for holes, rocks, roots and other hidden hazards in the terrain. Keep away from any drop-offs. Beware of overhead obstructions (low limbs, etc.) and underground obstacles (sprinklers, pipes, tree roots, etc.). Cautiously enter a new area. Be alert for hidden hazards.
- Disengage power to cutter deck before backing up. Do not mow in reverse unless absolutely necessary and then only after observation of the entire area behind the mower. If you must mow in reverse, maintain a constant lookout to the rear of the machine and mow slowly.
- DO NOT turn sharply. Use care when backing up.

12. Disengage power to cutter deck before crossing roads, walks or gravel drives.
13. Mow only in daylight or good artificial light.
14. NEVER raise the deck with the blades engaged.
15. Take all possible precautions when leaving the machine unattended, such as disengaging the mower, lowering the attachments, setting the parking brake, stopping the engine, and removing the key.
16. Disengage power to the attachments when transporting or when not in use.
17. The machine and attachments should be stopped and inspected for damage after striking a foreign object, and damage should be repaired before restarting and operating the machine.

CAUTION

Do not touch the engine or the muffler while the engine is running or immediately after stopping. These areas may be hot enough to cause a burn.

DANGER

DO NOT run the engine inside a building or a confined area without proper ventilation. Exhaust fumes are hazardous and contain carbon monoxide which can cause brain injury and death.

18. Keep hands and feet away from cutter blades and moving parts. Contact can injure.
19. Transport the mower using a heavy duty trailer or truck. Ensure the trailer or truck has all of the necessary lighting and markings as required by laws, codes, and ordinances. Secure a trailer with a safety chain.
20. Be cautious when loading and unloading onto trailers or trucks. Use only a full width ramp. Ramp angle should be no more than 15 degrees. Back up the ramp and drive down forward.
21. When transporting the mower, make sure the park brake is engaged, the steering control levers are in the neutral position, the engine is off with the key removed, and the wheels have been blocked.

22. Tie the mower down securely using straps, chains, cable, or ropes. Both front and rear straps must be directed down and outward from machine.
23. Use care when approaching blind corners, shrubs, trees, or other objects that may obscure vision.
24. NEVER leave the machine running unattended.

2.6 ROLL-OVER PROTECTION SYSTEM

WARNING

The seat belt must be securely fastened during operation. Failure to do so could cause serious injury or loss of life.

This mower has been designed for good traction and stability under normal mowing conditions. However, caution must be used when traveling on slopes, especially when the grass is wet. Do not mow on wet grass. Wet grass reduces traction and steering control.

Any or all parts of the Roll-Over Protection System MUST NOT be removed. Failure to adhere to this guideline could result in injury or death.

WARNING

There is no roll-over protection when the roll bar is in the down position.

Lower the roll bar only when absolutely necessary.

Raise the roll bar as soon as clearance permits.

DO NOT wear the seat belt when the roll bar is in the down position.

ALWAYS wear seat belt when roll bar is in the up position.

Operate the machine smoothly, no sudden turns, starts or stops.

Check the area carefully before mowing for proper overhead clearance (i.e. branches, doorways, etc.).

DO NOT contact any overhead object with the roll bar.

Section 2

Lower the roll bar only when absolutely necessary.

1. To lower the roll bar, remove the hairpin cotter pins and remove the two (2) lock pins. See Figure 2-2.
2. Lower the roll bar to the down position.
3. To raise the roll bar, lift the bar to the upright position.

Install the two (2) lock pins through the hole, secure with the two (2) hairpin cotter pins. See Figure 2-2.

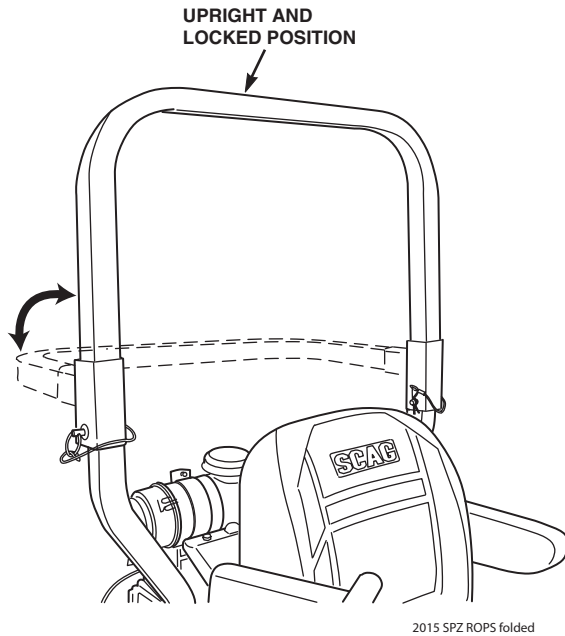

Figure 2-1. Foldable Roll-Over Protection System

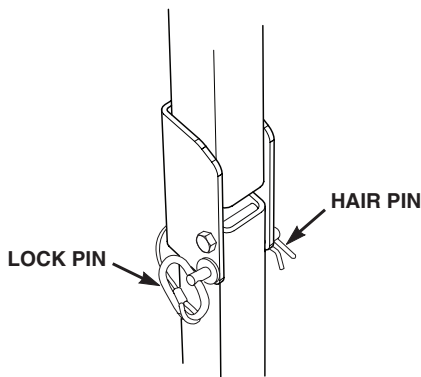

Figure 2-2. ROPS Hinge

The potential exposure of the seat belt to severe environmental conditions make it crucial to inspect the seat belt system regularly.

It is recommended that the seat belt be inspected on a daily basis for signs of damage. Any seat belt system that shows cuts, fraying, extreme or unusual wear, significant discoloration due to UV exposure, dirt or stiffness, abrasion to the seat belt webbing, or damage to the buckle, latch plate, hardware or any other obvious problem should be replaced immediately.

WARNING

Failure to properly inspect and maintain the seat belt can cause serious injury or loss of life.

1. Check the full length of the seat belt webbing for cuts, wear, fraying, dirt and stiffness. See Figure 2-3.
2. Check the seat belt webbing in areas exposed to ultra violet rays from the sun or extreme dust or dirt. If the original color of the webbing in these areas is extremely faded and/or is packed with dirt, the physical strength of this webbing may have deteriorated. If this condition exists, replace the seat belt system.
3. Check the buckle and latch for proper operation and determine if the latch plate is excessively worn, deformed, or if the buckle is damaged or cracked. See Figure 2-3.

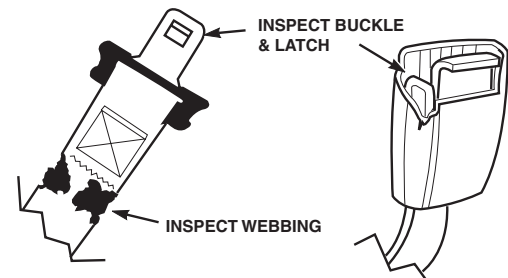

Figure 2-3. Seat Belt Inspection

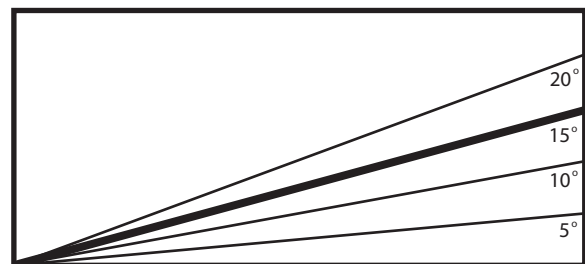

Figure 2-4. Slope Angle Graph

 **WARNING**

Reduce speed when turning, operating on slopes, slick or wet surfaces. Allow extra distance to stop.

Stay off of slopes too steep for safe operation. To check a slope, attempt to back up it (with the cutter deck down). If the machine can not back up the slope without the wheels slipping, do not operate the machine on this slope. Under no circumstances should the machine be operated on slopes greater than 15 degrees. See Figure 2-4 to determine approximate slope.

DO NOT mow near drop-offs, ditches or embankments. The machine could suddenly roll over if a wheel goes over the edge or if the edge caves in.

Operate the machine smoothly, no sudden turns, starts or stops on a slope.

NEVER tow on slopes. The weight of the towed equipment may cause loss of traction and loss of control.

DO NOT permit untrained personnel to operate the machine.

Be cautious when loading and unloading onto trailers or trucks.

Use only a full width ramp.

Ramp angle should be no more than 15 Degrees. See Figure 2-4 to help determine approximate slope.

Back up the ramp and drive down forward.

2. Disengage drives, lower implement, set parking brake, stop engine and remove key or disconnect spark plug wire to prevent accidental starting of the engine when servicing or adjusting the machine. Wait for all movement to stop before adjusting, cleaning or repairing.
3. Disconnect battery or remove spark plug wire before making any repairs. Disconnect the negative terminal first and the positive last. Reconnect the positive first and the negative last.
4. Keep all nuts, bolts and screws tight, to ensure the machine is in safe working condition. Check blade mounting bolts frequently to be sure they are tight.
5. Do not change the engine governor settings or overspeed the engine. See the engine operator's manual for information on engine settings.
6. To reduce fire hazard, keep the cutting units, drives, muffler and engine free of grass, leaves, excessive grease, oil and dirt.
7. Park the machine on level ground and engage the parking brake.
8. NEVER allow untrained personnel to service the machine.
9. Use care when checking blades. Use a Blade Buddy, wrap the blade(s) or wear gloves and USE CAUTION when servicing blades. Only replace blades. NEVER straighten or weld blades.
10. Keep all parts in good working condition. Replace all worn or damaged decals.
11. Use jack stands to support components when required.
12. Carefully release pressure from components with stored energy.

2.7 MAINTENANCE CONSIDERATIONS & STORAGE

1. Never make adjustments to the machine with the engine running unless specifically instructed to do so. If the engine is running, keep hands, feet, and clothing away from moving parts.

 WARNING

Hydraulic fluid is under high pressure and can penetrate skin causing injury. If hydraulic fluid is injected into the skin, it must be surgically removed within a few hours by a doctor or gangrene may result.

Keep body and hands away from pinholes or nozzles that eject hydraulic fluid under high pressure. Use paper or cardboard and not hands to search for leaks.

Safely relieve all pressure from the hydraulic system by placing the control levers in the neutral lock position and shutting off the engine before performing any work on the hydraulic system.

If you need service on your hydraulic system, please see your authorized Scag dealer.

13. Let the engine cool before storing.
14. DO NOT store the machine near an open flame.
15. Shut off fuel while storing or transporting.
16. DO NOT store fuel near flames or drain indoors.
17. Charge batteries in an open, well ventilated area, away from spark and flames. Unplug charger before connecting or disconnecting from battery. Wear protective clothing and use insulated tools.

2.8 USING A SPARK ARRESTOR

The engine in this machine is not equipped with a spark arrestor muffler. It is in violation of California Public Resource Code Section 4442 to use or operate this engine on or near any forest covered, brush covered or grass covered land unless the exhaust system is equipped with a spark arrestor meeting any applicable local or state laws. Other states or federal areas may have similar laws. Check with your state or local authorities for regulations pertaining to these requirements.

2.9 SPARK IGNITION SYSTEM

This spark ignition system complies with Canadian ICES-002.

2.10 SAFETY AND INSTRUCTIONAL DECALS

⚠ DANGER

SPINNING BLADES

KEEP CLEAR

BLADE CONTACT & THROWN OBJECTS CAN INJURE

483505

⚠ WARNING

Replace seat only with Scag approved seat with seat mounting provisions and Scag approved seat belts.

Failure to follow these directions could result in injury or death in the event of a rollover.

483633

⚠ WARNING

DO NOT OPERATE WITHOUT DISCHARGE CHUTE, MULCHING KIT, OR ENTIRE GRASS CATCHER INSTALLED

483405

⚠ WARNING

INSTALL BELT COVER BEFORE OPERATING MACHINE

READ OPERATOR'S MANUAL

483402

⚠ WARNING

ROTATING BLADES AND BELTS

- * Keep hands, feet & clothing clear
- * Keep all guards in place
- * Shut off engine & disengage blade clutch before servicing
- * Use caution in directing discharge
- * Read instruction manual before operating

DO NOT OPERATE UNLESS GRASS CATCHER, MULCHING KIT OR DISCHARGE CHUTE IS INSTALLED

483406

⚠ WARNING

Operation of this equipment may create sparks that can start fires around dry vegetation. A spark arrester may be required. The operator should contact local fire agencies for laws or regulations relating to fire prevention requirements.

483900

(supplied with California models only)

↑ FORWARD

F

R ↓

REVERSE

481568

⚠ DANGER

Avoid injury from burns

- Shut off engine
- Allow to cool several minutes
- Remove cap slowly
- Do not overfill

Molded in Fuel Tank

⚠ WARNING

SERIOUS INJURY OR DEATH MAY RESULT FROM MACHINE ROLLOVER

Failure to follow these instructions could result in serious injury or death

- Do not operate machine on steep slopes or near drop offs
- Avoid sharp and/or quick turns
- Do not exceed the machine weight rating on the ROPS
- Always use the seat belt
- Do not jump if machine tips while ROPS is fully extended and using seat belt
- If ROPS is foldable: Keep ROPS fully extended whenever possible

WHEN ROPS MUST BE DOWN:

- Do not use the seat belt
- Drive with extra care

483300

IMPORTANT

Operation on slopes can be hazardous.

This machine was originally equipped with a Rollover Protection Device with a Roll Bar and Seat Belt.

See your dealer if either is missing or damaged.

483425

PARKING BRAKE

TO ENGAGE PARKING BRAKE:

- *Fully depress foot pedal
- *Pull back and hold latch handle while releasing pedal

TO DISENGAGE PARKING BRAKE:

- *Depress and release pedal

484461

IMPORTANT ADJUSTMENT PROCEDURES

READ OPERATOR'S MANUAL FOR MORE DETAILS

Check tire pressure - Drive tires-8 psi -
- Caster tires-25 psi

FREE WHEEL OPERATION

To move machine without running engine, pull both dump valve rods up and back (located at rear of machine) and latch. Pull rods forward and latch into front slot to operate mower.

NEUTRAL ADJUSTMENT

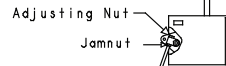

To re-set neutral, loosen jamnut. With operator in seat, control levers in neutral and brake off, turn adjusting bolt until wheel doesn't creep. Tighten jam nut. Repeat for opposite side. If wheels still creep after adjustment, see an authorized Scag dealer.

TRACKING ADJUSTMENT



If machine pulls to right, adjust LH control stop bolt CW (inward) to slow left wheel down. If machine pulls to left, adjust RH control stop bolt CW (inward) to slow right wheel down.

483660

HYDRAULIC FLUID LEVEL

Check hydraulic fluid level while fluid is cool. Fluid level should be in sight window. Fill with 20W50 motor oil only.

IMPORTANT

Do not overfill. Room for hot fluid expansion must be allowed or resulting expansion may cause leaks in the system

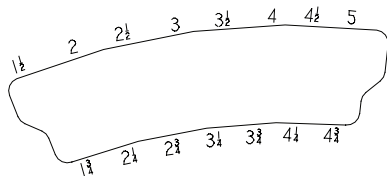

SCAG PATRIOT

⚠ WARNING

AVOID SERIOUS INJURY OR DEATH

- *Read the Operator's Manual
- *Rollite etiquette on asphalt or a distributor Scag
- *Operate only on slopes you can back up
- *If machine stops going uphill, stop blades and back down slowly
- *Avoid sudden turns
- *Do not mow when children or others are around
- *Never carry children even with blades off
- *Look down and behind before and while backing
- *Keep safety devices (guards, shields, switches, etc.) in place and working
- *Remove objects that could be thrown by the blades
- *Trained operators only

START/DRIVE PROCEDURE

- Engage parking brake
- Disengage mower deck drive
- Move control handles to neutral position
- Start Engine
- Release parking brake
- Select forward or reverse with hydro control levers

DECK LATCH RELEASE

486303

SPECIFICATIONS**3.1 ENGINE**

General TypeHeavy Duty Industrial/Commercial Gasoline

Model:

Scag Model SPZ52H-22FXKawasaki FX691V
 Scag Model SPZ61H-23FXKawasaki FX730V
 Scag Model SPZ52H-23CVKohler CV732
 Scag Model SPZ61H-25CVKohler CV742

Displacement:

Kawasaki 22FX (FX691V) 726cc
 Kawasaki 23FX (FX730V) 726cc
 Kohler 23CV 732cc
 Kohler 25CV 742cc

Type 4 Cycle Gasoline, Twin Cylinder, Vertical Shaft

Cylinders 2 with Cast Iron Sleeves

Governor Mechanical Type with Variable Speed Control Set At 3600 RPM

Idle Speed:

Kawasaki 1550 RPM
 Kohler 1750 RPM

Fuel Pump Integral Fuel Pump with In-Line Fuel Filter

Fuel Non-Leaded Gasoline with a Minimum Octane Rating of 87

Oil Pump Positive Displacement Gerotor™

Starter Electric Starting with Bendix Shift Starter

Belts Kevlar cord. Self-adjusting, Self-tightening

3.2 ELECTRICAL

Battery 12 Volt

Charging System Alternator

Charging Output:

Kawasaki 12 Volt, 13 Amp

System Polarity Negative Ground

Starter 12 Volt Electric Ring Gear Type, Key Operated

Interlock Switches Seat, Neutral Control, Mower Engagement (PTO), Parking Brake

Instrument Panel Key Switch, Throttle Lever, Manual Choke, PTO Switch

Fuses Two (2) 20 Amp

3.3 MOWER

Drive System Hydraulic Drive with Two Hydro-Gear™ Integrated Zero-Turn Axles

Scag Model SPZ52H Hydro-Gear™ ZT-3100

Scag Model SPZ61H Hydro-Gear™ ZT-3400

Steering/Travel Control Twin Lever Fingertip Steering Control

with Individual Control to Each Wheel with Gas Spring Dampers

Parking Brake Lever Actuated Linkage to Brakes on Both Drive Wheel Axles

Wheels:

(2) Front Caster SPZ52H 13 X 5-6 Two-Ply

(2) Front Caster SPZ61H 13 X 6.50-6 Four Ply

(2) Drive SPZ52H 22 X 10.5-12 Four-Ply Pneumatic Tubeless, Radius Edge

(2) Drive SPZ61H 24 X 12-12 Four-Ply Pneumatic Tubeless, Radius Edge

Tire Pressure:

Front Caster..... 25 PSI
 Drive 8 PSI

Fuel TankSingle 6-1/2 Gallon Seamless Roto-Low Perm Tank with Large Opening and Fuel Cap
 SeatPadded, Thick Cushion with Suspension Seat

Travel Speed:

52" Forward 0 up to 8.5 MPH
 61" Forward 0 up to 10 MPH
 Reverse 0 up to 5 MPH

-NOTE- The machine will travel up to either 8.5 or 10 mph for transport purposes. For best cutting performance the forward travel speed should be adjusted depending upon the cutting conditions.

3.4 CUTTER DECK

Type Floating, Adjustable, Anti-Scalping, Hybrid Design Combines Out-Front and Belly-Mount Designs
 Construction10-Gauge top with 11-Gauge reinforcement throughout the spindle area, 7-Gauge skirt for strength and longevity

True Cutting Width:

5252" (122.0 cm)
 6161" (154.94 cm)

Cutting Height Adjustment.....Foot-Operated Lever Adjustment from Operator's Seat, 1.5" to 5" in 1/4"increments

Cutter Blades.....0.197 in. Thick, Milled Edge, Wear Resistant

Blade Engagement..... Electric Blade Engagement Clutch with Control Panel Switch
 Connected to the Cutter Deck through a Belt

Discharge Opening..... Extra Wide Discharge Opening with Spring-Loaded Discharge Chute

Discharge Chute.....Black, Polypropylene (Plastic), Flexible

Spindles..... Heavy-Duty Spindle Shaft, Cast Aluminum Housing, Sealed Ball Bearing, Maintenance-Free

Spindle Pulleys..... Split Steel

Cutter Deck Belts..... B-section with Kevlar Cord. Self-Adjusting, Self-Tightening

Electric Clutch Type Ogura Heavy Duty PTO Clutch Brake

3.5 HYDRAULIC SYSTEM

Hydraulic Oil Filter 40 Micron Spin-on Element Type

Hydraulic Expansion Reservoir Nylon

3.6 WEIGHTS AND DIMENSIONS

	52H	61H
Length.....	73"	79"
Tracking Width.....	47.5"	50.5"
Overall Width w/chute down.....	64.5"	73.5"
Overall Width w/chute up.....	53"	62"
Overall Height.....	61"	61.5"
Operating Weight.....	907-911#	952-956#

3.7 PRODUCTIVITY

	52H	61H
Cutting Width.....	52"	61"
Acres Per Day.....	20.2	23.7

The preceding chart will aid you in determining how many acres your Scag mower will cut per day. The chart is an estimate based on 8 hours per day cutting time at 6 MPH with a 20% allowance for overlap and turns.

OPERATING INSTRUCTIONS

WARNING

Do not attempt to operate this mower unless you have read this manual. Learn the location and purpose of all controls and instruments before you operate this mower.

4.1 CONTROLS AND INSTRUMENT IDENTIFICATION

Before operating the mower, familiarize yourself with all mower and engine controls. Knowing the location, function and operation of these controls is important for safe and efficient operation of the mower.

1. **Ignition Switch (Figure 4-1).** The ignition switch is used to start the engine and has three positions; OFF, ON, and START.
2. **Mower Deck Switch (Figure 4-1).** Used to engage and disengage the mower drive system. Pulling up on the switch will engage the deck drive. Pushing down on the switch will disengage the deck drive.
3. **Engine Choke Control (Figure 4-1).** Used to start a cold engine.
4. **Engine Throttle Control (Figure 4-1).** Used to control the engine speed. Pushing the lever forward increases engine speed. Pulling the lever back decreases engine speed. Full back position is the IDLE position. Full forward is the cutting position.
5. **Fuel Gauge (Figure 4-1).** Indicates the amount of fuel in the fuel tank.

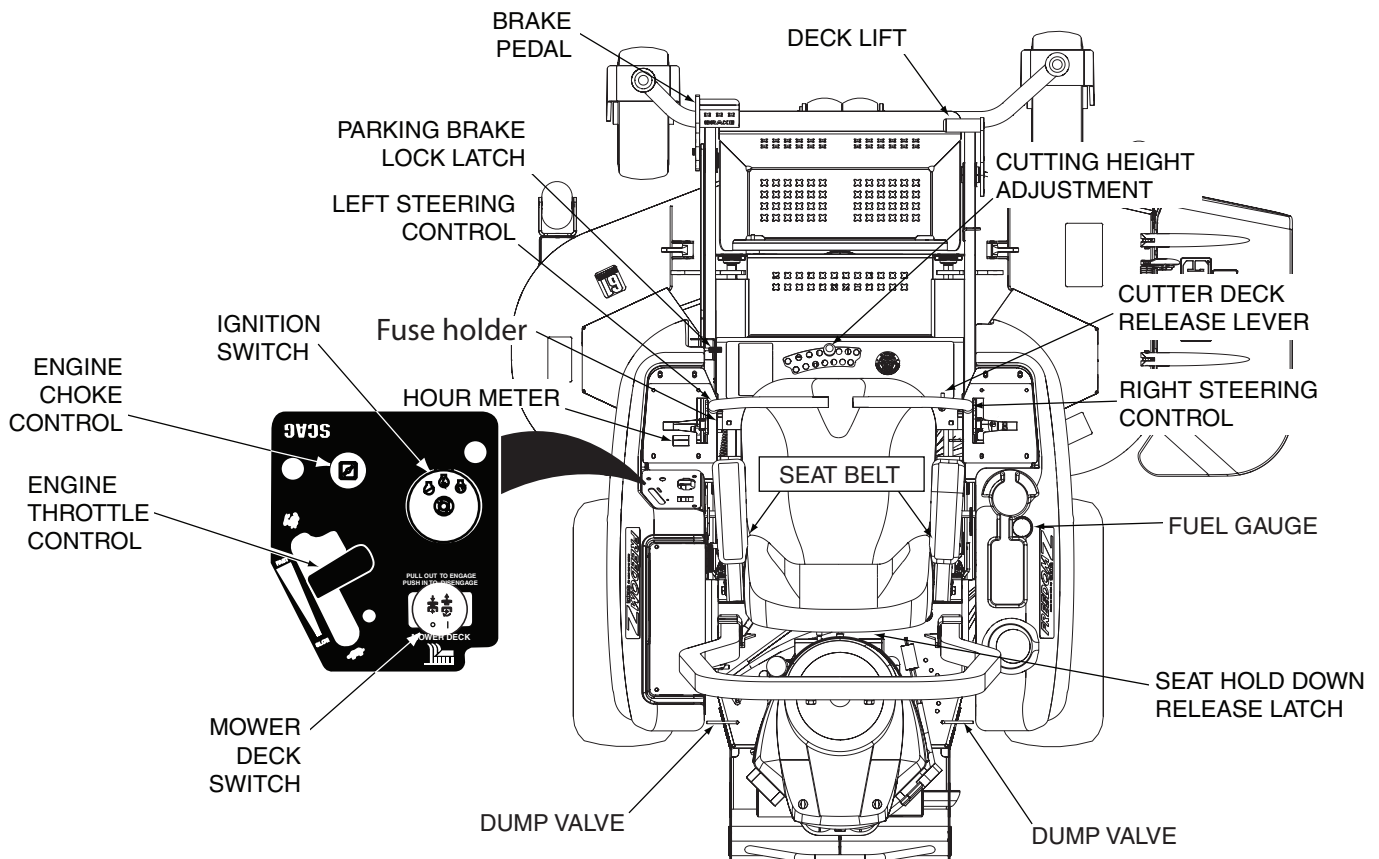

Figure 4-1. Controls and Instruments

6. **Hourmeter (Figure 4-1).** Indicates the number of hours the engine has been operated. It operates whenever the engine is running. Has preset maintenance reminders for engine and hydraulic system oil changes. Will start flashing scheduled maintenance 2 hours before preset time and continue flashing until 2 hours after. Automatically resets.
7. **Fuse Holders (Figure 4-1).** Two 20-amp fuses protect the mower's electrical system. To replace fuses, pull fuse out of the socket and install a new fuse.
8. **Left Steering Control (Figure 4-1).** Used to control the mower's left wheel when traveling forward or reverse.
9. **Right Steering Control (Figure 4-1).** Used to control the mower's right wheel when traveling forward or reverse.
10. **Brake Pedal (Figure 4-1).** Depressing the brake pedal applies the brake.
11. **Parking Brake Lock Latch (Figure 4-1).** Used to lock the parking brake in the engaged position. Fully depress the brake pedal and pull the parking brake lock latch back to lock the parking brake in the engaged position. See Figure 4-2. Fully depress the brake pedal forward to disengage the parking brake lock latch, then release the brake pedal to disengage the brake. See Figure 4-3.

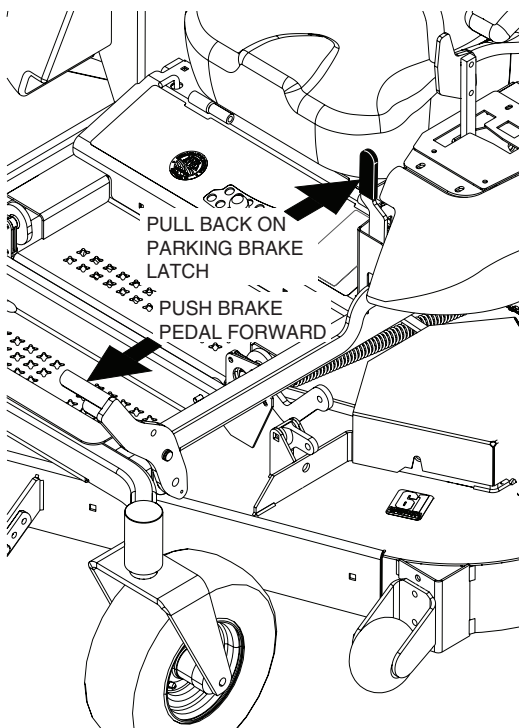

Figure 4-2. Engaging the Parking Brake

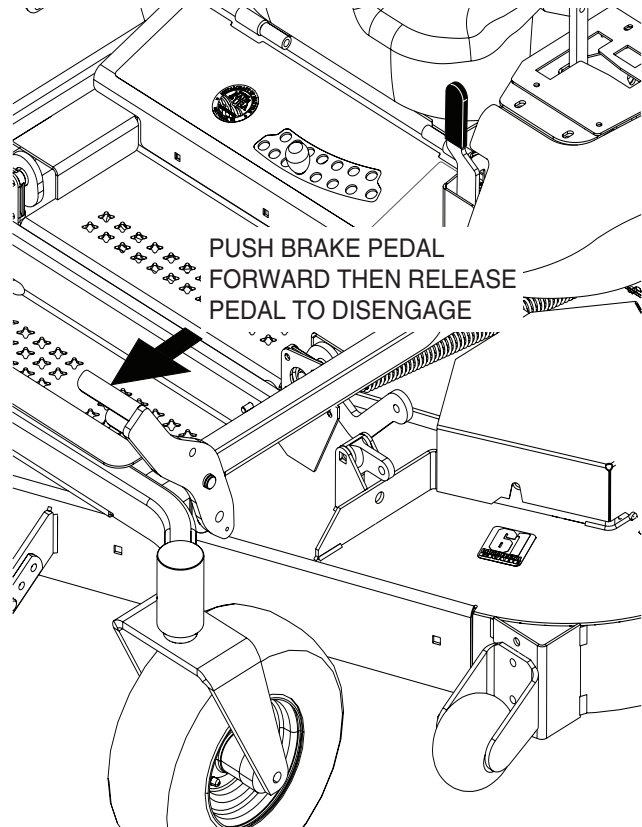

Figure 4-3. Releasing the Parking Brake

12. **Dump Valve Control Levers (Figure 4-4).** Located on the left and right side of the bumper, used to "free-wheel" the mower. Rotating the levers forward into the notch (towards the front of the mower) allows the unit to move under hydraulic power. Rotating the levers backward to the notch (towards the rear of the mower) allows the mower to be moved by hand (free-wheeling).

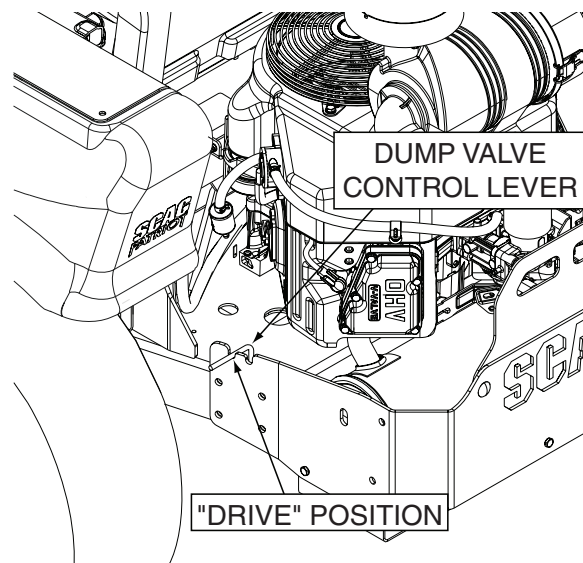

Figure 4-4. Dump Valve Control

Section 4

13. **Deck Lift Foot Lever (Figure 4-1).** Used to raise and lower the cutter deck.
14. **Cutting Height Adjustment (Figure 4-1).** Used to set the cutter deck at the desired cutting height.
15. **Deck Release Lever (Figure 4-1).** Used to lock the cutter deck in the transport position. Push the foot pedal forward and pull back on the release lever to release the cutter deck for normal mowing.
16. **Seat Belt (Figure 4-1).** Used to secure the operator. Seat belt must be worn at all times during operation.
17. **Seat Hold Down Release Latch (Figure 4-1).** Located behind the seat. Used to secure the seat in the operator's position. Release the latch to gain access under the seat.

4.2 SAFETY INTERLOCK SYSTEM

The mower is equipped with a safety interlock system that prevents the engine from starting unless the deck drive is disengaged, the steering control levers are in the neutral position and the operator is in the seat. The interlock system shuts off the engine if the operator leaves the seat with the steering control levers not in the neutral position and/or the cutter blades engaged and the parking brake not engaged.



WARNING

Never operate the mower with the interlock system disconnected or malfunctioning. Do not disengage or bypass any switch; injury to yourself and others or property damage could result.

4.3 TESTING THE SAFETY INTERLOCK SYSTEM

1. Sit in the seat in the operating position, engage the parking brake, place the steering control levers in the neutral lock position, and engage the PTO switch to the ON (up) position. Try to start the engine; the engine should not start
2. Sit in the seat in the operating position, engage the parking brake, move the PTO switch to the OFF (down) position, move either of the steering control handles out of the neutral lock position. Try to start the engine; the engine should not start. Repeat for the other steering control lever.

-NOTE-

3. All SPZ models will start with the parking brake engaged or disengaged. For all test procedures listed below, the engine should be started with the parking brake engaged unless specified otherwise.
4. Sit in the seat in the operating position, engage the parking brake, place the steering control levers in the neutral lock position, move the PTO switch to the OFF (down) position, and start the engine. With the engine running, release the parking brake and rise slightly off of the seat. The engine should shut off.
5. Sit in the seat in the operating position, engage the parking brake, place the steering control levers in the neutral lock position, move the PTO switch to the OFF (down) position, and start the engine. With the engine running, engage the PTO switch to the ON (up) position, and rise slightly off of the seat. The engine should shut off.
6. Sit in the seat in the operating position, engage the parking brake, place the steering control levers in the neutral lock position, move the PTO switch to the OFF (down) position, and start the engine. With the engine running, move either steering control lever out of the neutral lock position. The engine should shut off. Repeat for the other steering control lever.

4.4 INITIAL RUN-IN PROCEDURES

FIRST DAY OF USE OR APPROXIMATELY 20 HOURS

1. Check all belts for proper alignment and wear at 2, 4 and 8 hours.
2. Change the engine oil and oil filter after the first 20 hours of operation. (See Section 7.3.)
3. Check hydraulic oil level in reservoir. (See Section 7.2.)
4. Check for loose hardware. Tighten as needed.
5. Check interlock system for proper operation. (See Section 4.2.)
6. Check tire pressure. Adjust pressure if necessary. (See Section 7.9.)

4.5 STARTING THE ENGINE

CAUTION

DO NOT USE STARTING FLUIDS. Use of starting fluids in the air intake system may be potentially explosive or cause a “runaway” engine condition that could result in engine damage and/or personal injury.

1. Be sure the fuel shutoff valve, located behind the operator's seat, is completely open.
2. Sit in the operator's seat, fasten seat belt and place the steering control levers in the neutral position.
3. Engage the parking brake.
4. Place the PTO switch in the disengaged position.
5. If the engine is cold, choke the engine as needed.
6. Move the engine throttle control to about half engine speed.
7. Turn the ignition key to the START position and release the key as soon as the engine starts. Do not hold the key in the START position for more than 15 seconds at a time. Allow at least 60 seconds between each cranking attempt to prevent overheating of the starter motor. Prolonged cranking can damage the starter motor and shorten battery life.
8. Allow engine to warm before operating the mower.

4.6 GROUND TRAVEL AND STEERING

- IMPORTANT -

If you are not familiar with the operation of a machine with lever steering and/or hydrostatic transmissions, the steering and ground speed operations should be learned and practiced in an open area, away from buildings, fences, or obstructions.

Learn the operation on flat ground before operating on slopes.

Start practicing with a slow engine speed and slow forward travel.

Learn to feather the steering controls to obtain a smooth operating action.

Practice operating the mower until you are comfortable with the controls before proceeding to mow.

FORWARD TRAVEL

To travel forward with the mower, fully depress the brake pedal forward to disengage the parking brake lock latch and release the brake pedal to disengage the brake, pull levers inward out of the neutral lock position and slowly push the steering control levers forward an equal distance. The further the steering control levers are pushed forward the greater the forward speed will be. To increase the speed, push the steering control levers further forward and to decrease the speed, pull the steering control levers back.

To stop the forward travel, pull the steering control levers back to the neutral position.

To steer the mower left while traveling forward, pull the left steering lever back. The further the lever is pulled back, the quicker the mower will turn left.

To steer the mower right while traveling forward, pull the right steering control lever back. The further the lever is pulled back, the quicker the mower will turn right.

- NOTE -

Smooth operation of the steering levers will produce smooth mower operation. While learning the operation of the steering controls, keep the travel speed low.

- IMPORTANT -

Do not travel forward over a curb. The mower will hang up on the curb. Raise the deck and travel backwards over the curb at a 45 degree angle. (See Figure 4-1 and Section 4-1 item 13 for cutter deck raising description.)

Section 4

REVERSE TRAVEL

CAUTION

Disengage power to the mower before backing up. Do not mow in reverse unless absolutely necessary and then only after observation of the entire area behind the mower.

CAUTION

Before backing up, observe the rear for persons and obstructions. Clear the area before backing up. Possible injury or property damage could occur.

To travel in reverse, pull levers inward out of the neutral lock position and pull both handles back. Keep the travel speed low while traveling in reverse.

- NOTE -

The mower may not travel straight in reverse. Slight adjustments may need to be made using the steering controls.

To steer left while traveling in reverse, allow the left steering control lever to move forward. The further the control is allowed to move forward, the quicker the mower will turn left.

To steer right while traveling in reverse, allow the right steering control lever to move forward. The further the control is allowed to move forward, the quicker the mower will turn right.

To stop the reverse travel, allow the steering control levers to return to the neutral position. If the mower is to be parked, place the handles in the neutral lock position, fully depress the brake pedal and pull back on the parking brake lock latch to engage the parking brake. See Figure 4-2.

4.7 ENGAGING THE DECK DRIVE (CUTTER BLADES)

1. Set the throttle at about 3/4 speed. Do not attempt to engage the deck drive at high speed as this shortens the electric clutch life — use only moderate engine speed when engaging the deck drive.
2. Engage the deck drive by pulling out on the yellow switch, located on the instrument panel, to the engage position. See Figure 4-5.

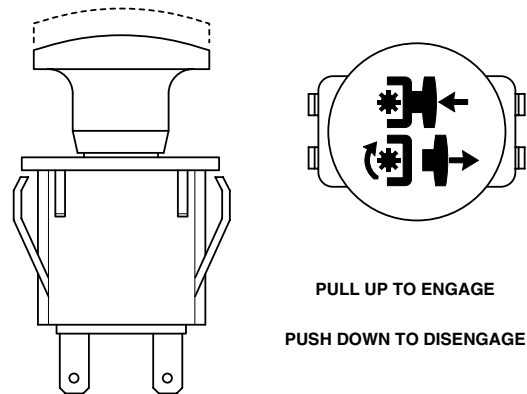

390S0138

Figure 4-5. Cutter Engage Switch

- NOTE -

A squealing noise may be heard when engaging or disengaging the deck drive. It is caused by the electric clutch plates meshing as the mower comes up to speed. This is normal.

3. To disengage the deck drive, push the switch in to the disengage position.
4. Always operate the engine at full throttle to properly maintain cutting speed. If the engine starts to lug down, reduce the forward speed and allow the engine to operate at maximum RPM.

4.8 HILLSIDE OPERATION

WARNING

DO NOT operate on steep slopes. To check a slope, attempt to back up it (with the cutter deck down). If the machine can back up the slope without the wheels slipping, reduce speed and use extreme caution. Under no circumstances should the machine be operated on slopes greater than 15 degrees. See Figure 2-4, Page 7 to help determine approximate slope of area to be mowed. ALWAYS FOLLOW OSHA APPROVED OPERATION.

1. This mower has been designed for good traction and stability under normal mowing conditions. However, caution must be used when traveling on slopes, especially when the grass is wet. Wet grass reduces traction and steering control. The Roll-Over Protection System is standard equipment for this machine. See Section 2.6, page 6-7 of this manual for further details.
2. Stay two cut widths away from slopes, drop offs, ditches and retaining walls.
3. Some areas may need to be mowed with a walk-behind mower or string trimmer.
4. To prevent tipping or loss of control, do not start or stop suddenly, avoid unnecessary turns and travel at reduced speed. If tires lose traction, disengage blades and proceed slowly off the slope.
5. Avoid sudden starts when mowing uphill. Sudden starts may cause the machine to tip backwards.
6. Loss of traction may occur when traveling down hill. Weight transfers to the front of the machine and may cause the drive wheels to slip causing loss of braking or steering.
7. Control of the mower sliding on a slope will not be regained by application of the brake.
8. Keep tires properly inflated.
9. Use caution when operating the mower on an incline with the optional grass catcher installed.

4.9 PARKING THE MOWER

1. Park the machine on a flat, level surface only. Do not park the machine on an incline.

2. Place the steering control levers in the neutral position.
3. Disengage the cutter blades.
4. Slow the engine to idle speed.
5. Fully depress the brake pedal and pull the parking brake lever back to engage the parking brake. See Figure 4-2.
6. Turn the ignition key to the OFF position and remove the key.

4.10 AFTER OPERATION

1. Wash the entire mower after each use. Do not use high pressure spray or direct the spray onto electrical components.

- IMPORTANT -

Do not wash a hot or running engine. Cold water will damage the engine. Use compressed air to clean the engine if it is hot.

2. Keep the entire mower clean to inhibit serious heat damage to the engine or hydraulic oil circuit.
3. Check the drive belts for proper alignment and any signs of wear. Correct and adjust if necessary.

DANGER

To avoid injury from burns, allow the mower to cool before removing the fuel tank cap and refueling.

4. After the mower has cooled down, fill the fuel tank with fresh, clean fuel at the end of every day of operation. See Engine Owner's Manual for proper octane requirements.
5. Check the tire pressure. Adjust pressure if necessary.

Section 4

4.11 REMOVING CLOGGED MATERIAL

DANGER

ROTATING BLADES

NEVER PUT YOUR HANDS INTO THE DISCHARGE CHUTE FOR ANY REASON!

Shut off the engine and remove the key and only then use a stick or similar object to remove material if clogging has occurred.

1. If the discharge chute becomes clogged, shut off the engine and remove the ignition key. Using a stick or similar item, dislodge the clogged material. Then resume normal mowing.

4.12 MOVING MOWER WITH ENGINE STOPPED

To “free-wheel” or move the mower around without the engine running, place the dump valve levers in the FREE-WHEEL position. See Figure 4-4, page 14. Disengage the parking brake and move the mower by hand. When the machine is in the desired position, engage the parking brake and place the dump valve levers in the DRIVE position. The dump valve levers must be returned to the DRIVE position to drive the mower.

4.13 RECOMMENDATIONS FOR MOWING

1. Do not mow with dull blades. A dull blade will tear grass, resulting in poor lawn appearance and reduced mowing power.

WARNING

DO NOT operate without Discharge Chute, Mulching Kit, or entire Grass Catcher properly installed.

2. The discharge chute must not be removed and must be kept in the lowest position to deflect grass clippings and thrown objects downward. Direct the side discharge away from sidewalks or streets to minimize cleanup of clippings. When mowing close to obstacles, direct the discharge away from the obstacles to reduce the chance of property damage by thrown objects.
3. Cut grass when it is dry and not too tall. Do not cut grass too short (cut off 1/3 or less of existing grass for best appearance). Mow frequently.
4. Keep mower and discharge chute clean.
5. When mowing wet or tall grass, mow the grass twice. Raise the mower to the highest setting for the first pass and then make a second pass to the desired height.
6. Use a slow travel speed for trimming purposes.
7. Operate the engine at full throttle for best cutting. Mowing with a lower RPM causes the mower to tear the grass. The engine is designed to be operated at full speed.
8. Use the alternate stripe pattern for best lawn appearance. Vary the direction of the stripe each time the grass is mowed to avoid wear patterns in the grass.

4.14 ADJUSTING CUTTING HEIGHT

The mower deck can be adjusted from a height of 1 inch to 4-1/2 inches at 1/4-inch intervals. To adjust the cutting height:

WARNING

DO NOT adjust the cutting height with the mower blades rotating. Disengage the power to the cutter blades and then adjust cutting height.

1. Disengage the power to the cutter blades.
2. Push the cutting height adjustment foot pedal all the way forward using your right foot until it locks in place. See Figure 4-6.

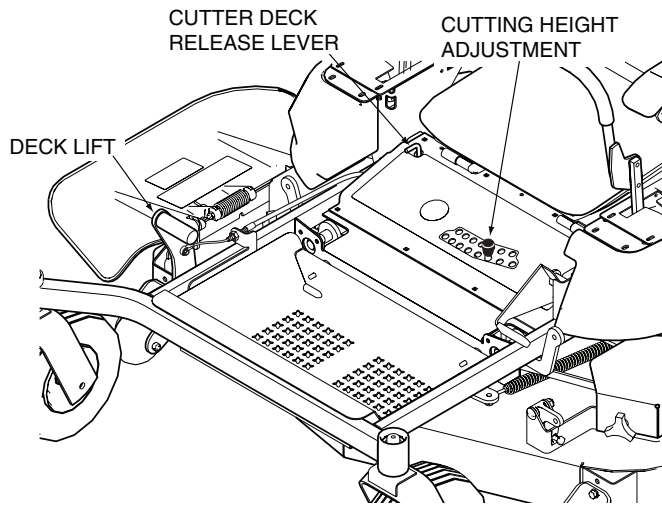

Figure 4-6. Adjusting Cutting Height

3. Insert the pin into the cutting height index at the desired cutting height. Push forward on the deck lift foot lever, hold in place and lift up on the deck release lever. See Figure 4-6. Slowly release the foot pedal. A deck height decal is located on the cutting height index as an aid in adjusting the deck to the desired height. See Figure 4-6.

4.15 TOWING (OPTIONAL HITCH ACCESSORY)

1. NEVER allow children or others in or on towed equipment.
2. Tow only with a machine that has a hitch designed for towing. Do not attach towed equipment except at the hitch point.
3. Follow manufacturer's recommendations for weight limit for towed equipment. 250/lbs. maximum towing weight.
4. NEVER TOW ON SLOPES. The weight of the towed equipment may cause loss of traction and loss of control.
5. Travel slowly and allow extra distance to stop.
6. Zero-turning with a trailer attached could cause damage to the trailer or mower.

TROUBLESHOOTING CUTTING CONDITIONS

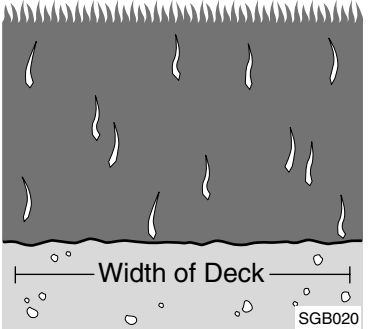
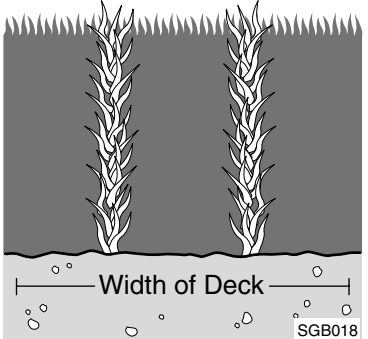
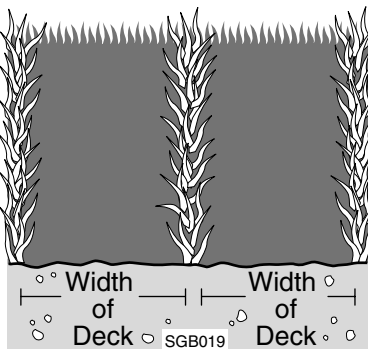
CONDITION	CAUSE	CURE
<p>STRINGERS - OCCASIONAL BLADES OF UNCUT GRASS</p> 	Low engine RPM	Run engine at full RPM
	Ground speed too fast	Slow speed to adjust for conditions
	Wet grass	Cut grass after it has dried out
	Dull blades, incorrect sharpening	Sharpen blades
	Deck plugged, grass accumulation	Clean underside of deck
	Belts slipping	Adjust belt tension
<p>STREAKING - STRIPS OF UNCUT GRASS IN CUTTING PATH</p> 	Dull, worn blades	Sharpen blades
	Incorrect blade sharpening	Sharpen blades
	Low engine RPM	Run engine at full RPM
	Belt slipping	Adjust belt tension
	Deck plugged, grass accumulation	Clean underside of deck
	Ground speed too fast	Slow speed to adjust for conditions
	Wet grass	Cut grass after it has dried out
	Bent blades	Replace blades
<p>STREAKING - STRIPS OF UNCUT GRASS BETWEEN CUTTING PATHS</p> 	Not enough overlapping between rows	Increase the overlap of each pass

TROUBLESHOOTING CUTTING CONDITIONS (CONT'D)

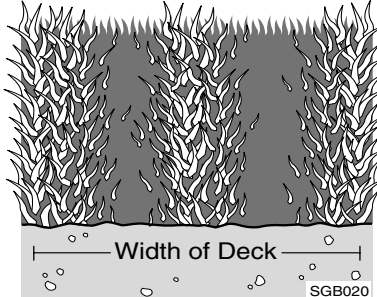
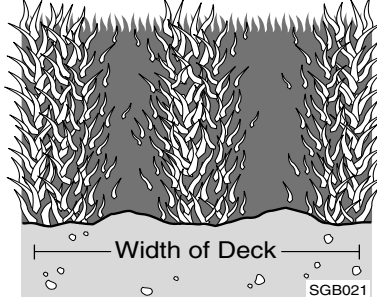
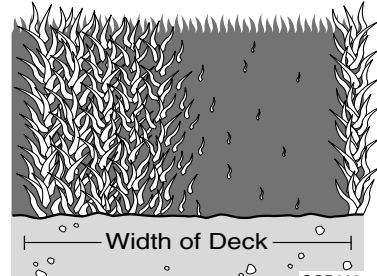
CONDITION	CAUSE	CURE
<p>UNEVEN CUT ON FLAT GROUND - WAVY HIGH-LOW APPEARANCE, SCALLOPED CUT, OR ROUGH CONTOUR</p>  <p style="text-align: right; font-size: small;">SGB020</p>	Lift worn from blade	Replace blade
	Blade upside down	Mount with cutting edge toward ground
	Deck plugged, grass accumulation	Clean underside of deck
	Too much blade angle (deck pitch)	Adjust pitch and level
	Deck mounted improperly	See your authorized SCAG dealer
	Bent spindle area	See your authorized SCAG dealer
	Dull blade	Sharpen blade
<p>UNEVEN CUT ON UNEVEN GROUND-WAVY APPEARANCE, HIGH-LOW SCALLOPED CUT, OR ROUGH CONTOUR</p>  <p style="text-align: right; font-size: small;">SGB021</p>	Uneven ground	May need to reduce ground speed, raise cutting height, and/or change direction of cut
<p>SLOPING RIDGE ACROSS WIDTH OF CUTTING PATH</p>  <p style="text-align: right; font-size: small;">SGB023</p>	Tire pressures not equal	Check and adjust tire pressure
	Wheels uneven	Check and adjust tire pressure
	Deck mounted incorrectly	See your authorized SCAG dealer
	Deck not level side-to-side	Check for level and correct

TROUBLESHOOTING CUTTING CONDITIONS (CONT'D)

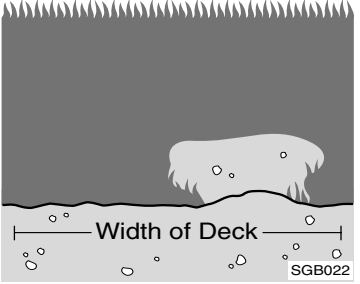
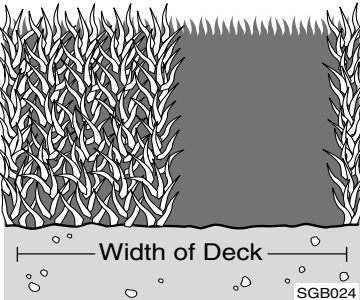
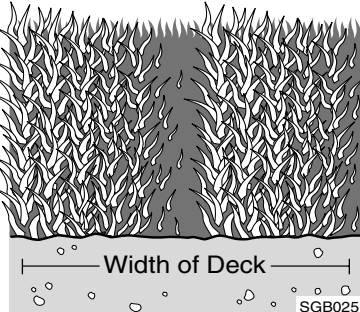
CONDITION	CAUSE	CURE
<p>SCALPING - BLADES HITTING DIRT OR CUTTING VERY CLOSE TO THE GROUND</p>  <p style="text-align: right; font-size: small;">SGB022</p>	Low tire pressures	Check and adjust pressures
	Ground speed too fast	Slow speed to adjust for conditions
	Cutting too low	May need to reduce ground speed, raise cutting height, change direction of cut, and/or change pitch and level
	Rough terrain	May need to reduce ground speed, raise cutting height, and/or change direction of cut
	Wet grass	Cut grass after it has dried out
<p>STEP CUT - RIDGE IN CENTER OF CUTTING PATH</p>  <p style="text-align: right; font-size: small;">SGB024</p>	Blades not mounted evenly	Adjust pitch and level
	Bent blade	Replace blade
	Internal spindle failure	See your authorized SCAG dealer
	Mounting of spindle incorrect	See your authorized SCAG dealer
<p>SLOPE CUT - SLOPING RIDGES ACROSS WIDTH OF CUTTING PATH</p>  <p style="text-align: right; font-size: small;">SGB025</p>	Bent spindle mounting area	See your authorized SCAG dealer
	Internal spindle failure	See your authorized SCAG dealer
	Bent deck housing	See your authorized SCAG dealer

ADJUSTMENTS

6.1 PARKING BRAKE ADJUSTMENT

WARNING

Do not operate the mower if the parking brake is not operable. Possible severe injury could result.

The parking brake linkage should be adjusted whenever the parking brake lock latch is placed in the “ENGAGE” position and the parking brake will not prevent the mower from moving. If the following procedures do not allow you to engage the parking brake properly, contact your Scag dealer for further brake adjustments.

1. Park the machine on a flat surface and block the caster wheels to prevent the machine from moving. Remove the ignition key.
2. Engage the parking brake. Fully depress the brake pedal and pull the parking brake lock latch back to lock the parking brake. See Figure 6-1.
3. Loosen the jam nut at the front of the brake linkage. See Figure 6-2.
4. With the parking brake in the locked position, turn the adjustment nut until the brake spring has an overall length of 2". See Figure 6-2.
5. Repeat steps 3 and 4 on the other side of the machine.
6. Test the parking brake.

- NOTE -

If this procedure does not achieve proper brake adjustment, please contact your authorized Scag dealer.

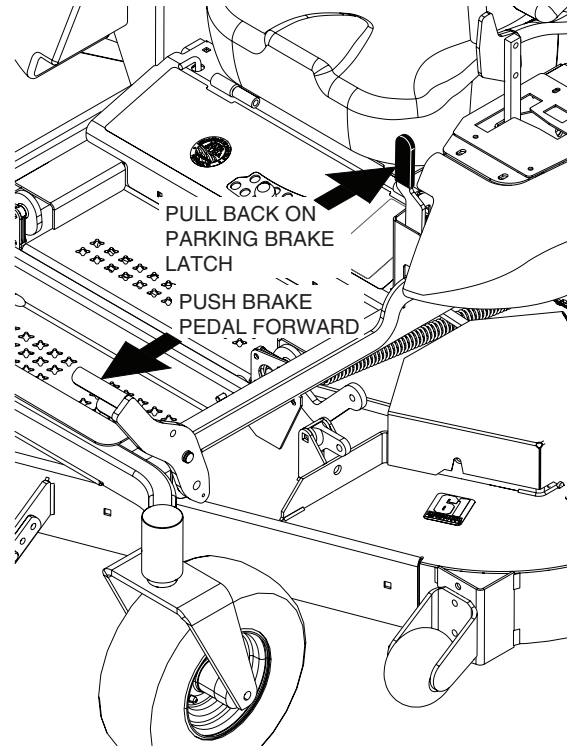

Figure 6-1. Brake Adjustment

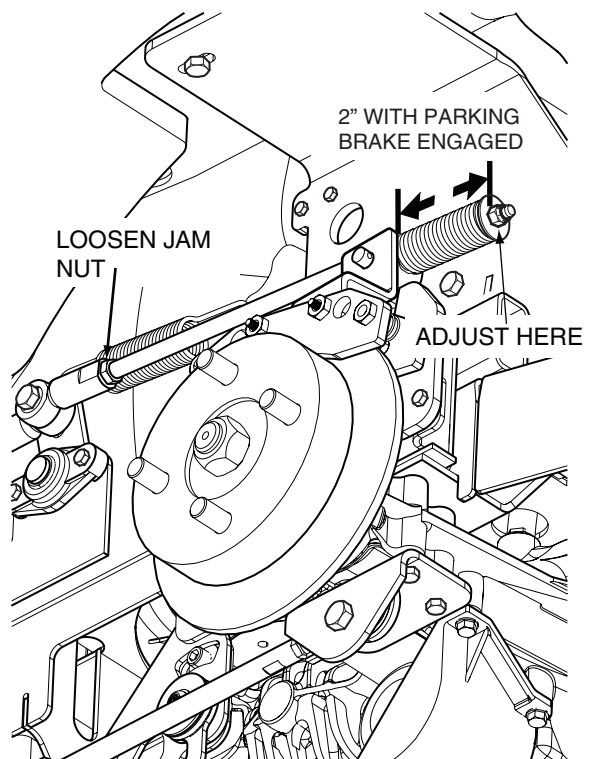

Figure 6-2. Brake Rod Adjustment

Section 6

6.2 TRAVEL ADJUSTMENTS

Neutral or tracking adjustments will need to be made if:

- A. The steering control levers are in the neutral position and the machine creeps forward or backward. (See Neutral Adjustment).
- B. The steering control levers are in the full forward position and the mower pulls to one side or the other when traveling in a forward direction. (Tracking Adjustment, See Page 26).

NEUTRAL ADJUSTMENT

1. Be sure the dump valve levers are in the run position and the steering control levers are in the neutral lock position.
2. With an operator in the seat, start the engine and disengage the parking brake.

3. Run the engine at full operating speed and check if the machine creeps forward or backwards.
4. Adjust the RH wheel by loosening the jam nuts on the steering control rod and turning the adjustment nut until the drive wheel turns in the forward direction. Turn the adjustment nut back until the drive wheel stops moving. Turn the adjustment nut an additional 1/2 turn. See Figure 6-3.
5. Tighten the jam nuts and repeat for the LH wheel. See Figure 6-3.
6. Actuate the steering control levers forward and reverse several times and return them to the neutral position.
7. Check that the drive wheels remained in neutral and readjust if necessary.

MOVE STEERING LEVER OUT TO THE NEUTRAL POSITION

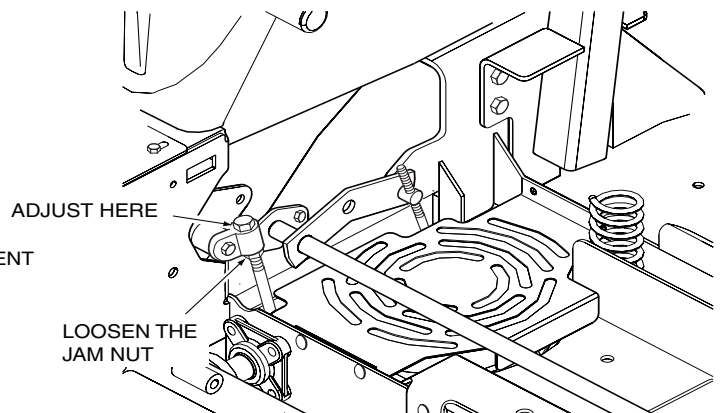
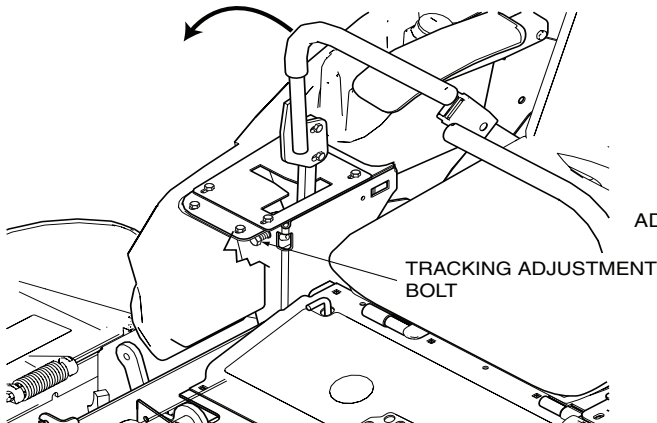

2015 SPZ SCRA

Figure 6-3. Steering Control Rod Adjustment

TRACKING ADJUSTMENT

CAUTION

Stop the engine and remove the key from the ignition before making any adjustments. Wait for all moving parts to come to a complete stop before beginning work.

CAUTION

The engine and drive unit can get hot during operation causing burn injuries. Allow engine and drive components to cool before making any adjustments.

- NOTE -

Before proceeding with this adjustment, be sure that the caster wheels turn plus pivot freely and that the tire pressure in the drive wheels is correct. If the tire pressure is not correct, the machine will pull to the side with the lower pressure.

1. If at full speed the mower pulls right, it is an indication that the left wheel is turning faster than the right wheel. To adjust this condition, proceed as follows:
 - A. Stop the machine and place the steering control levers in the neutral position. Turn the tracking adjustment bolt for the LH pump inward (clockwise). This will cause the control rod to stroke the LH pump less, slowing down the LH wheel. See Figure 6-3.
2. If at full speed the mower pulls left, it is an indication that the right wheel is turning faster than the left wheel. To adjust this condition, proceed as follows:
 - A. Stop the machine and place the steering control levers in the neutral position. Turn the tracking adjustment bolt for the RH pump inward (clockwise). This will cause the control rod to stroke the RH pump less, slowing down the RH wheel. See Figure 6-3.

- NOTE -

If after making the adjustment as outlined do not correct the tracking or neutral, contact your local Authorized Scag Power Equipment Dealer.

6.3 THROTTLE CONTROL AND CHOKE ADJUSTMENTS

These adjustments must be performed by your Authorized Scag Power Equipment Dealer to ensure proper and efficient running of the engine. Should either need adjustment, contact your authorized Scag service center.

6.4 BELT ADJUSTMENT

WARNING

Before removing any guards, shut the engine off and remove the ignition key.

All drive belts are spring loaded and self-tensioning, however after the first 2, 4, 8 and 10 hours of operation, the belts should be checked for proper alignment and wear. Thereafter, check the belts after every 40 hours of operation or weekly, whichever occurs first.

WARNING

If the pump drive belt fails, steering control will be lost which could result in serious injury or death. Replace the pump drive belt as needed or every 400 hours / 2 years, whichever occurs first.

6.5 BELT ALIGNMENT

Belt alignment is important for proper performance of your Scag mower. If you experience frequent belt wear or breakage, see your authorized Scag service center for belt adjustment.

Section 6

6.6 CUTTER DECK ADJUSTMENTS

Cutter deck level, pitch and height are set at the factory. However, if these adjustments should ever need to be made, the following procedures will aid in obtaining the proper cutter deck adjustment.

- NOTE -

Before proceeding with the cutter deck adjustments, be sure that all tires are properly inflated.

CUTTER DECK LEVEL

The cutter deck should be level from side-to-side for proper cutting performance. To check for level, be sure that the mower is on a flat, level surface, the tires are properly inflated and the cutter deck is set at the most common cutting height that you will use. On the RH side of the machine, check the distance from the top of the cutter deck to the floor. Next check the distance from the top of the cutter deck to the floor on the LH side of the machine. Both measurements should be the same. If the two measurements are different, the cutter deck level must be adjusted as follows:

1. If the cutter deck is lower on one side, loosen the elastic stop nuts securing the deck level links on the front and rear of the lower side. See Figure 6-4.

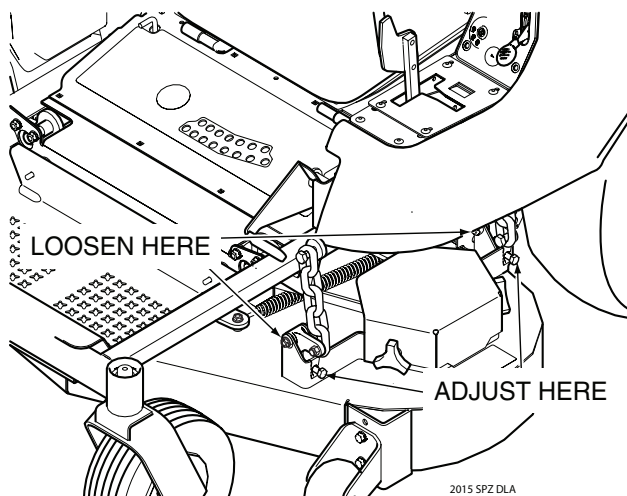

Figure 6-4. Cutter Deck Level Adjustment

2. Turn the adjustment bolts on the front and rear deck level links clockwise until the cutter deck is level between both sides. See Figure 6-4
3. Tighten the two (2) elastic stop nuts to secure the cutter deck in the proper position.

CUTTER DECK PITCH

The pitch of the cutter deck should be equal between the front and rear of the cutter deck for proper cutting performance. To check for proper deck pitch, be sure that the mower is on a flat, level surface and the tires are properly inflated.

Check the distance from the top of the cutter deck to the floor at the rear RH side of the cutter deck directly behind the cutter deck hanging chains. Next check the distance from the top of the cutter deck to the floor at the front RH side of the cutter deck directly in front of the cutter deck hanging chains. The measurement at the front of the cutter deck should be the same as the rear of the deck. Make these measurements at the LH side of the cutter deck also. If the measurement at the front of the deck is not the same, the cutter deck pitch must be adjusted as follows:

1. Loosen the elastic stop nuts securing the deck level links on the front of the cutter deck on both sides. See Figure 6-5 and 6-6.

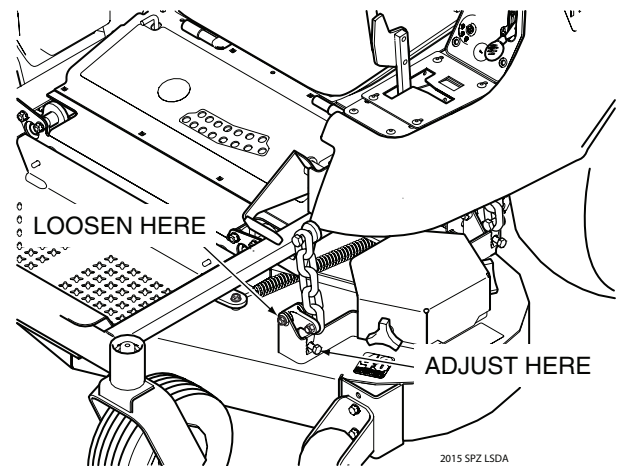

Figure 6-5. Cutter Deck Pitch Adjustment

2. Turn the adjustment bolts on both sides either clockwise to raise or counter-clockwise to lower the front of the cutter deck until the measurements are equal. Tighten the elastic stop nuts.

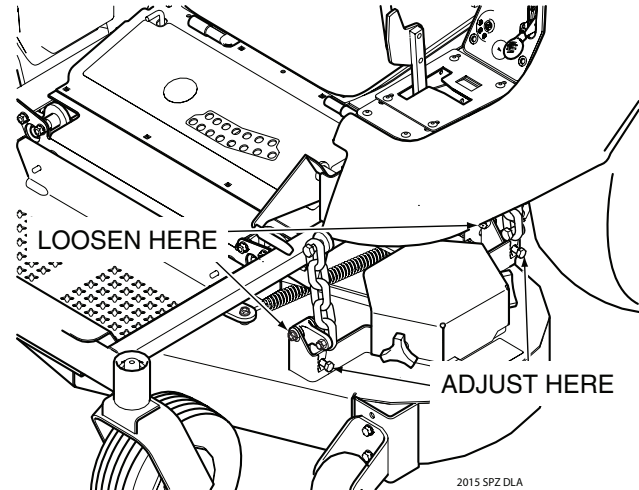
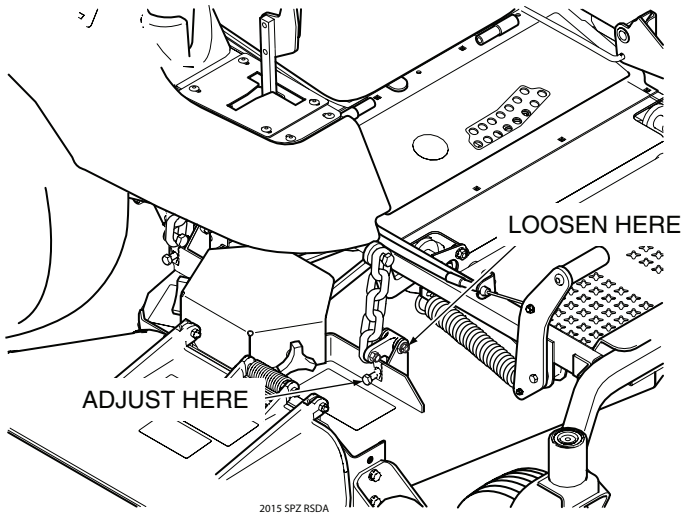

Figure 6-6. Cutter Deck Pitch Adjustment

- NOTE -

To prevent the cutter deck from teetering, all four (4) cutter deck hanging chains must have tension on them. If all four chains do not have tension on them and the deck teeters, you must readjust the cutter deck as outlined in the procedures above. All measurements should be taken from the top edge of the deck as the deck has an uneven bottom edge.

CUTTER DECK HEIGHT

The cutter deck height adjustment is made to ensure that the cutter deck is cutting at the height indicated on the cutting height index gauge. To check for proper deck height, be sure that the mower is on a flat, level surface and the tires are properly inflated.

1. Place the cutter deck in the 3" cutting position. Push on the cutter deck foot pedal and pull up on the cutter deck release lever to lower the cutter deck.
2. Check the measurement from the floor to the cutter blade tip. If the measurement is not 3", an adjustment can be made using the deck level links.
3. Loosen the elastic stop nuts securing the deck level links. See Figure 6-7.

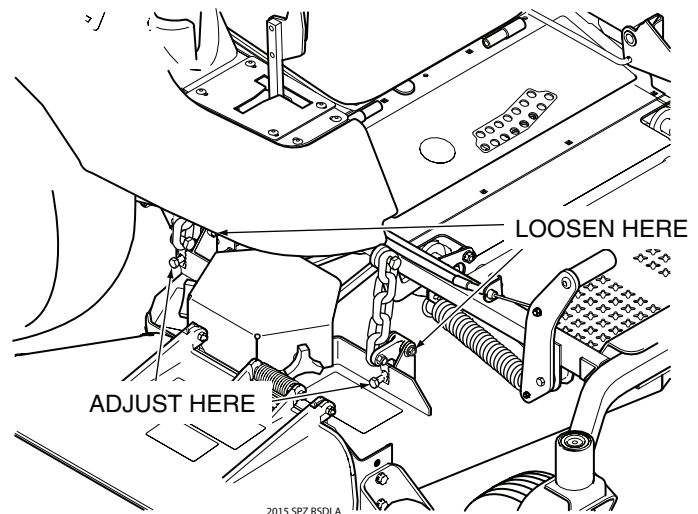

Figure 6-7. Cutter Deck Height Adjustment

4. Turn the adjustment bolts equal amount of turns either clockwise to raise or counter-clockwise to lower the cutter deck until the measurement at the cutter blade is 3" on both sides.
5. Tighten the elastic stop nuts on the deck level links.

Section 6

6.7 ELECTRIC CLUTCH ADJUSTMENT

The electric clutch serves two functions in the operation of the mower. In addition to starting and stopping the power flow to the cutter blades, the clutch also acts as a brake to assist in stopping blade rotation when the PTO is switched off or the operator presence circuit is interrupted.

When the clutch is disengaged, the air gap between the armature and rotor must be adjusted to fifteen thousandths of an inch, 0.015, for proper operation. The airgap adjustment is made at three bolts on the clutch. There are three inspection windows, one next to each adjusting bolt. See Figure 6-8.

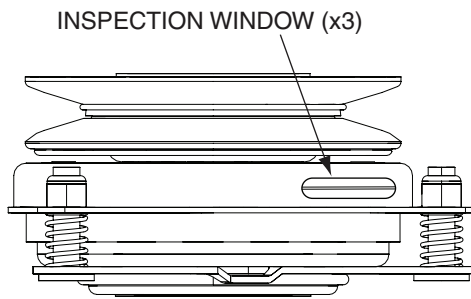

Figure 6-8. Clutch Air Gap Adjustment

1. Locate the inspection windows on the clutch.
2. Place a 0.015 feeler gauge in the slot between the rotor and the armature. See Figure 6-9.

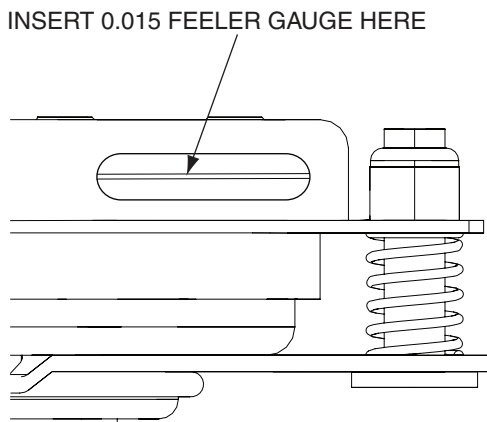

Figure 6-9. Clutch Air Gap Adjustment

3. Tighten or loosen the adjusting bolt as needed to achieve the 0.015 inch airgap. See Figure 6-10. Perform this operation at all three inspection windows.

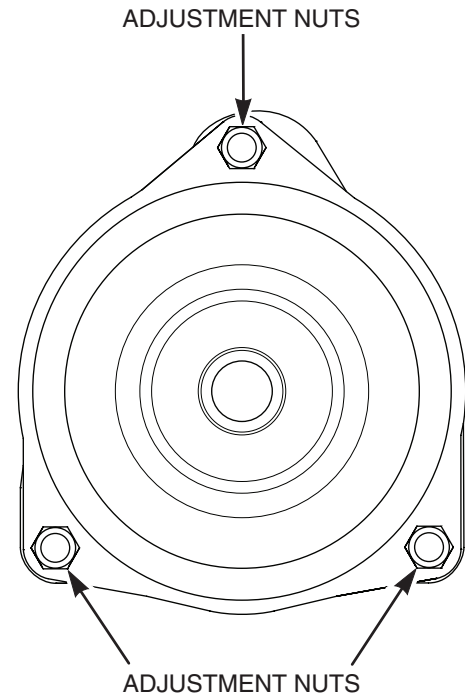

Figure 6-10. Clutch Air Gap Adjustment

This adjustment should be done every 500 hours of operation or annually, whichever comes first. In cases where the machine is heavily used, airgap settings should be checked more often.

If the air gap is too narrow, the clutch armature may drag when disengaged, resulting in premature failure.

If the air gap is too wide, the clutch may be slow to engage as the magnet must pull the armature in from a greater distance.

MAINTENANCE

7.1 MAINTENANCE CHART - RECOMMENDED SERVICE INTERVALS

BREAK-IN (FIRST 10)	HOURS							PROCEDURE	COMMENTS
	8	20	40	100	200	400	500		
X								Check all hardware for tightness	
X								Check hydraulic oil level	See paragraph 7.2
X								Check all belts for proper alignment	See paragraph 7.7
	X							Check engine oil level	See paragraph 7.3
	X							Check hydraulic hoses for leaks	Use extreme caution when checking the hydraulic hoses. See paragraph 2.6
	X							*Clean mower	See paragraph 7.10
	X							Check condition of blades	See paragraph 7.8
	X							Check tire pressure	See paragraph 7.9
	X							Inspect seat belt for wear or damage	See paragraph 2.6
	X							Check safety interlock system	See paragraph 4.3
		X						Change engine oil and filter	See paragraph 7.3
			X					Grease front caster wheel bearings	
			X					Check battery, clean battery posts and cables	See paragraph 7.6
			X					Inspect pump drive belt. Replace every 400 hours or 2 years, whichever occurs first.	See paragraph 6.4 & 7.7
			X					Check belts for proper alignment	See paragraph 7.7
				X				Check condition of fuel lines	
				X				Change engine oil	See paragraph 7.3
				X				Drain hydraulic system, replace hydraulic oil and filters	Use SAE 20W50 Motor Oil. See paragraph 7.2
				X				*Clean air cleaner element	See paragraph 7.5
					X			Check all hardware for tightness	
					X			Change engine oil and filter	See paragraph 7.3
					X			Check hydraulic oil level	See paragraph 7.2
						X		Replace engine fuel filter	See paragraph 7.4
						X		Adjust electric PTO clutch	See paragraph 6.7
							X	Drain hydraulic system, replace hydraulic oil and filters	Use SAE 20W50 Motor Oil. See paragraph 7.2
							X	Grease caster wheel pivot	See Paragraph 7.11

* Perform these maintenance procedures more frequently under extreme dusty or dirty conditions

Section 7

7.2 HYDRAULIC SYSTEM

A. CHANGING HYDRAULIC OIL

The hydraulic system oil and filter should be changed after the first 75-100 hours of machine operation and every 400 hours or annually thereafter, whichever occurs first. The oil should also be changed if the color of the fluid has become black or milky. A black color and/or a rancid odor usually indicates possible overheating of the oil, and a milky color usually indicates water in the hydraulic oil.

- IMPORTANT -

The hydraulic system oil should be changed if you notice the presence of water or a rancid odor to the hydraulic oil.

1. Park the mower on a level surface and stop the engine.
2. Remove the three 1/4" filter guard screws and filter guard from both axles. See Figure 7-1. Clean any loose debris around the perimeter of the filter.

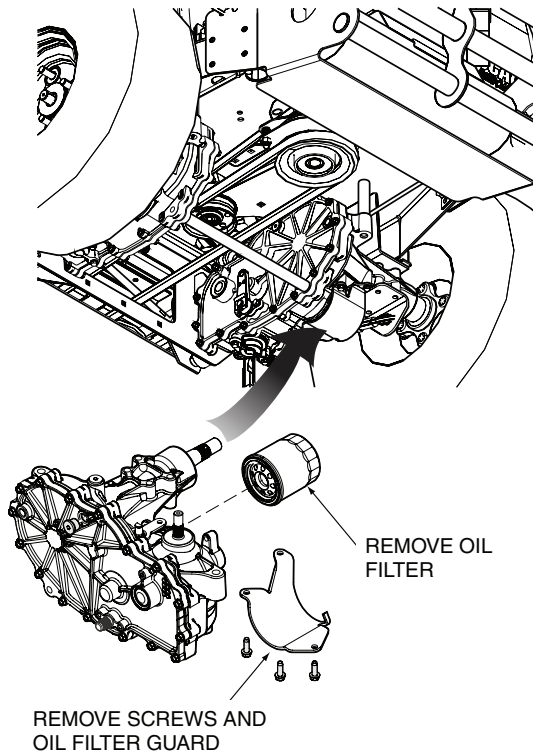

Figure 7-1. Hydraulic Oil Filter and Drain Plug

3. Place a suitable container under the hydraulic oil filters.

4. Remove the hydraulic filters from both axles and allow the fluid to drain into the container. Properly discard the oil when the system has drained completely. See Figure 7-2.
5. Once the hydraulic system has drained, install new hydraulic oil filters to both axles by hand, turn 3/4 to one complete turn after filter gasket contacts the filter base.
6. Reinstall the filter guards and torque the screws to 65 in/lbs.
7. Remove the side top port plug from both transaxles before filling with oil. See Figure 7-2.

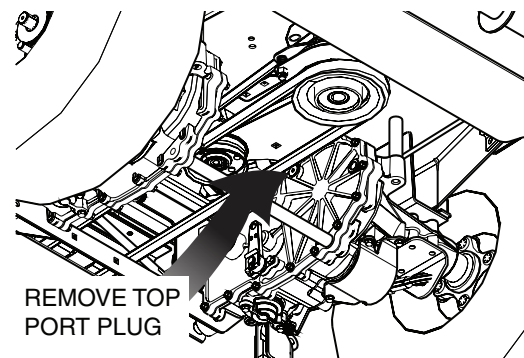

Figure 7-2. Top Port Plug Location

8. Remove the fill port plug from the top of both transaxle. See Figure 7-3. Fill each transaxle with Scag Hydraulic System Oil (p/n 486255 - 1 Quart or p/n 486254 - 1 Gallon) oil until the oil just appears at the bottom of each axle top port. Approximately 2 quart capacity per transaxle (4 quart total). Reinstall the top port plugs and torque to 180 in/lbs.

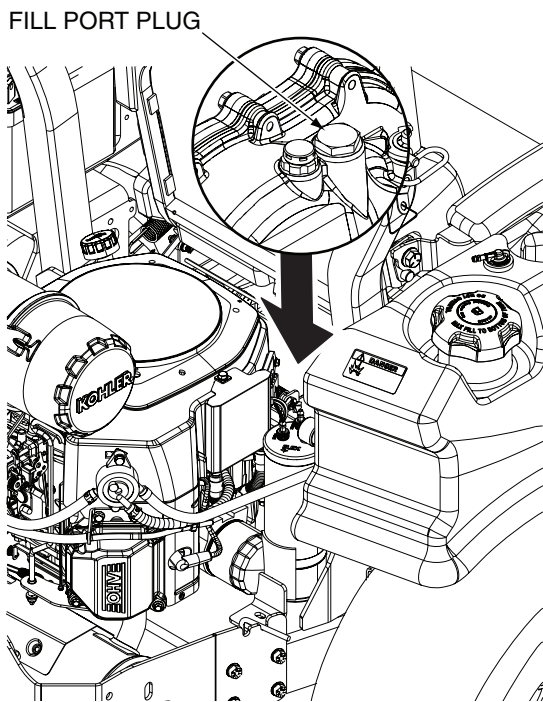

Figure 7-3. Right Side Fill Port Plug

9. Reinstall the fill port plug on the top of the transaxle.
10. The hydraulic system will need to be purged of all air. Raise the rear of the machine so the drive wheels are off the ground. Use jackstands and block the front caster wheels to prevent the machine from moving.
11. Move the dump valve control levers to the "freewheel" position. See Figure 7-4.

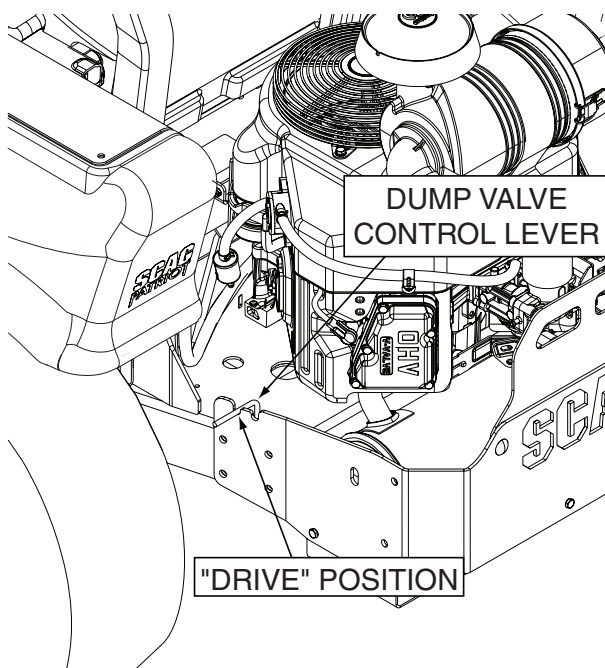

Figure 7-4. Dump Valve Control Lever

12. While in the operator's position, start the engine and disengage the parking brake.
13. Run the engine at 1/2 throttle and move the steering control levers to full forward and reverse 5 to 6 times.
14. Engage the parking brake. Move the dump valve control levers to the "drive" position. See Figure 7-4.
15. While in the operator's position, run the engine at 1/2 throttle. Release the parking brake, move the steering control levers to full forward and reverse 5 to 6 times. It may be necessary to repeat steps 12 to 15 until the air is completely purged from the system.
16. After the purge process is complete, remove the side top port plug from both transaxles to check the oil level. See Figure 7-2. If necessary, fill oil until the oil just appears at the bottom of each axle top port.

7.3 ENGINE OIL

A. CHECKING ENGINE CRANKCASE OIL LEVEL

The engine oil level should be checked after every 8 hours of operation or daily as instructed in the Engine Operator's Manual furnished with this mower.

B. CHANGING ENGINE CRANKCASE OIL

After the first 20 hours of operation, change the engine crankcase oil and replace the oil filter. Thereafter, change the engine crankcase oil after every 100 hours of operation or bi-weekly, whichever occurs first. Refer to the Engine Operator's Manual furnished with this mower for instructions.

C. CHANGING ENGINE OIL FILTER

After the first 20 hours of operation, replace the engine oil filter. Thereafter, replace the oil filter after every 200 hours of operation or every month, whichever occurs first. Refer to Engine Operator's Manual for instructions.

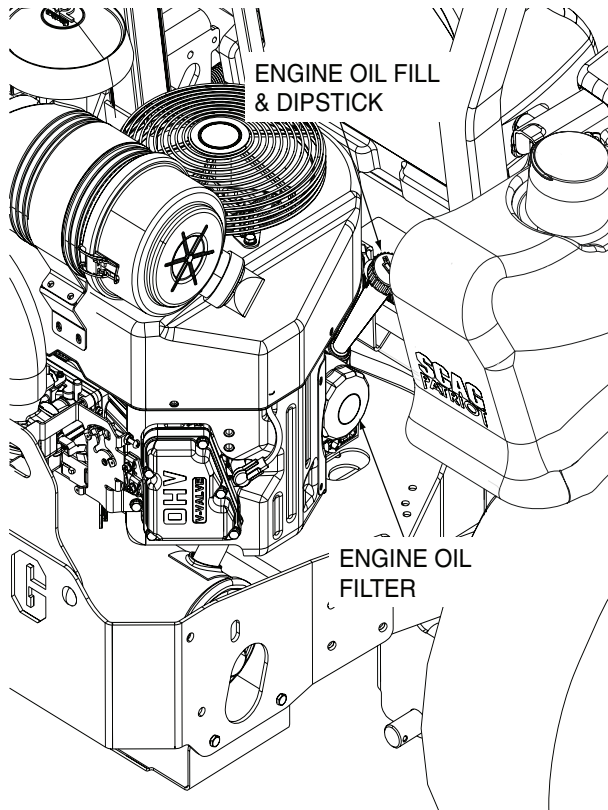

Figure 7-5. Oil Fill / Dipstick, Oil Filter

7.4 ENGINE FUEL SYSTEM

! DANGER

To avoid injury from burns, allow the mower to cool before removing the fuel tank cap and refueling.

A. FILLING THE FUEL TANK

Fill to the bottom of the filler neck insert (approximately 6-1/2 gallons on SPZ52/61 indicating Full (F) on the fuel gauge) at the beginning of each operating day. See Figure 7-6. Do not overfill. Use clean, fresh unleaded gasoline with a minimum octane rating of 87 and a maximum of 10% Ethanol.

DO NOT use E85 Fuel. Using E85 Fuel will cause severe damage to the engine.

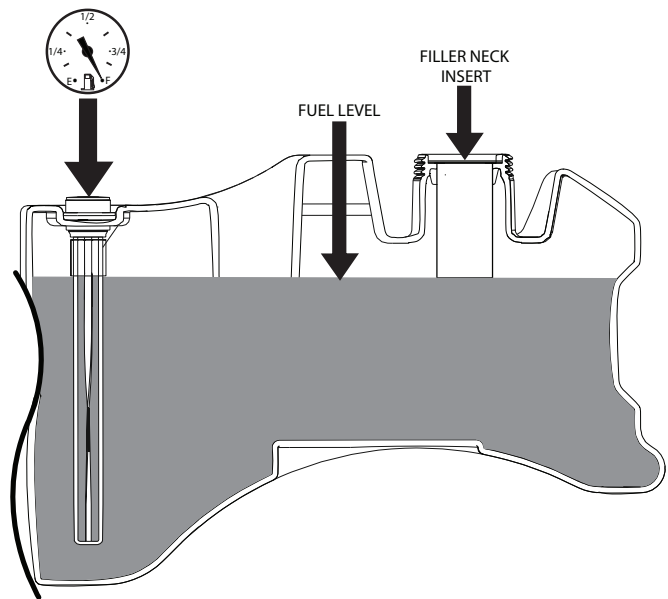

Figure 7-6. C.A.R.B. / EPA Phase 3 Fuel Level

To avoid personal injury or property damage, use extreme care in handling gasoline. Gasoline is extremely flammable and the vapors are explosive.

Extinguish all cigarettes, cigars, pipes and other sources of ignition.

1. Use only an approved gasoline container.
2. Never remove the gas cap or add fuel with the engine running. Allow the engine to completely cool before fueling.
3. Never fuel the machine indoors or in an enclosed trailer.
4. Never store the machine or fuel container where there is an open flame, spark or pilot light such as on a water heater or other appliances.
5. Never fill containers inside a vehicle or on a truck or trailer bed with a plastic liner. Always place containers on the ground away from your vehicle before filling.
6. Remove the machine from the truck or trailer and fuel on level ground. If this is not possible, then refuel the machine with a portable container, rather than from a gasoline dispenser nozzle.
7. Keep the nozzle in contact with the rim of fuel tank or container opening at all times until fueling is complete. Do not use a nozzle lock-open device.

8. If fuel is spilled on clothing, change clothing immediately and wash affected skin.
9. Replace gas cap and tighten securely. For Low Emission (LE) and EPA Phase 3 (produced after 1/1/2011) models, tighten the fuel cap until it ratchets.

B. REPLACING IN-LINE FUEL FILTER ELEMENTS

The engine fuel filter should be replaced after every 400 hours of operation or annually, whichever occurs first. See Figure 7-7.

1. Close the shut-off valve.
2. Remove and replace the engine fuel filter. Open the fuel shut-off valve.

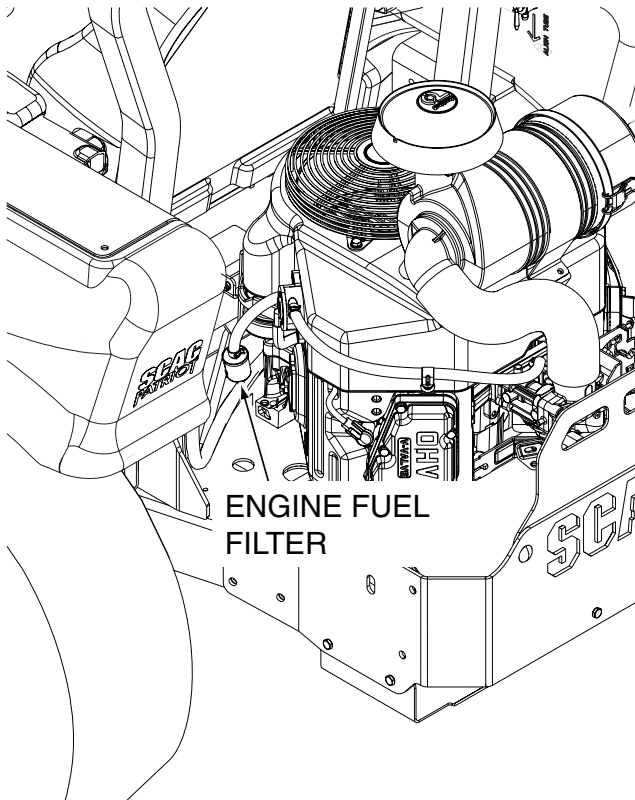

Figure 7-7. Fuel Filter

7.5 ENGINE AIR CLEANER

A. CLEANING AND/OR REPLACING AIR CLEANER ELEMENT

For any air cleaner, the operating environment dictates the air cleaner service periods. Inspect and clean the air cleaner element after every 100 hours of operation or bi-weekly, whichever occurs first and replace the element if required.

- NOTE -

In extremely dusty conditions it may be necessary to check the element once or twice daily to prevent engine damage.

1. Loosen the two bolts securing the air cleaner cover to the air cleaner assembly and remove the cover. Set aside.
2. Remove the air cleaner and inspect.
3. Clean or replace the air cleaner and foam pre-cleaner as recommended by the engine manufacturer.
4. Replace the air cleaner cover and secure.

7.6 BATTERY

WARNING

Lead-acid batteries produce flammable and explosive gases. To avoid personal injury when checking, testing or charging batteries, DO NOT use smoking materials near batteries. Keep arcs, sparks and flames away from batteries. Provide proper ventilation and wear safety glasses.

WARNING

Battery posts, terminals, and related accessories contain lead and lead compounds, chemicals known to cause cancer and reproductive harm. Wash hands after handling.

WARNING

Electric storage battery fluid contains sulfuric acid which is **POISON** and can cause **SEVERE CHEMICAL BURNS**. Avoid contact of fluid with eyes, skin, or clothing. Use proper protective gear when handling batteries. **DO NOT** tip any battery beyond 45° angle in any direction. If fluid contact does occur, follow first aid suggestions below.

BATTERY ELECTROLYTE FIRST AID

External Contact — Flush with water.

Eyes — Flush with water for at least 15 minutes and get medical attention immediately.

Internal — Drink large quantities of water. Follow with Milk Of Magnesia, beaten egg, or vegetable oil. Get medical attention immediately. In case of internal contact, DO NOT give fluids that would induce vomiting.

A. CHARGING THE BATTERY

Refer to the battery charger's manual for specific instructions.

Under normal conditions the engine's alternator will have no problem keeping a charge on the battery. If the battery has been completely discharged for a long period of time, the alternator may not be able to recharge the battery, and a battery charger will be required.

DO NOT charge a frozen battery. It may explode and cause injury. Let the battery warm before attaching a charger.

Whenever possible, remove the battery from the mower before charging and make sure the electrolyte covers the plates in all cells.

WARNING

BATTERIES PRODUCE EXPLOSIVE GASES. Charge the battery in a well ventilated space so gases produced while charging can dissipate.

Charging rates between 3 and 50 amperes are satisfactory if excessive gassing or spewing of electrolyte does not occur or the battery does not feel excessively hot (over 125°F). If spewing or gassing occurs or the temperature exceeds 125°F, the charging rate must be reduced or temporarily stopped to permit cooling.

B. JUMP STARTING

1. The booster battery must be a 12 volt type. If a vehicle is used for jump starting, it must have a negative ground system.
2. When connecting the jumper cables, connect the positive cable to the positive battery post, then connect the negative cable to the negative battery post.

7.7 DRIVE BELTS

All drive belts are spring-loaded and self-tensioning, however after the first 2, 4, 8 and 10 hours of operation, the belts should be checked for proper alignment and wear. Thereafter, check the belts after every 40 hours of operation or weekly, whichever occurs first.

- NOTE -

If you experience frequent belt wear or breakage, see your authorized Scag service center for belt adjustment.

WARNING

If the pump drive belt fails, steering control will be lost which could result in serious injury or death. Replace the pump drive belt as needed or every 400 hours / 2 years, whichever occurs first.

7.8 CUTTER BLADES

A. BLADE INSPECTION

1. Remove the ignition key before servicing the blades.
2. Raise the mower deck to the highest position. Place the lanyard pin in the highest cutting height position to prevent the cutter deck from falling.

WARNING

Always wear proper hand and eye protection when working with cutter blades.

3. Check the cutter blades for straightness. If the cutter blades appear bent, they will need to be replaced.
4. Check the cutter blades for wear. If any part of the cutter blade is worn to 1/2 its original thickness, replace the cutter blade.

WARNING

Do not attempt to straighten a bent blade, and never weld a broken or cracked blade. Always replace it with a new blade to assure safety.

5. If a blade cutting edge is dull or nicked, it should be sharpened. Remove the blades for sharpening. See "Blade Replacement."

- NOTE -

Keep the blades sharp. Cutting with dull blades not only yields a poor mowing job, but slows the cutting speed of the mower and causes extra wear on the engine and the blade drive by pulling hard.

B. BLADE SHARPENING

- NOTE -

If possible, use a file to sharpen the blade. Using a wheel grinder may burn the blade.

- NOTE -

DO NOT sharpen the blades beyond 1/3 of the width of the blade. See Figure 7-8.

1. Sharpen the cutting edge at the same bevel as the original. See Figure 7-8. Sharpen only the top of the cutting edge to maintain sharpness.

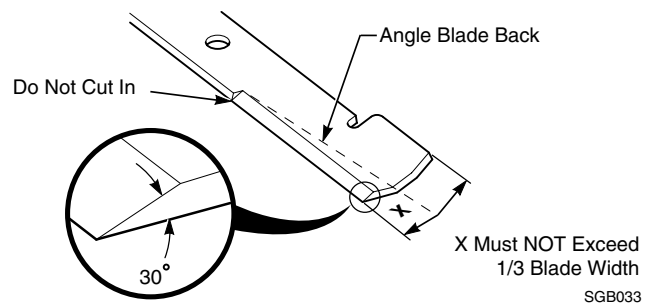

Figure 7-8. Blade Sharpening

2. Check the balance of the blade. If the blades are out of balance, vibration and premature wear can occur. The cutter blades should be balanced to 1-1/2 oz-in. See your authorized Scag dealer for blade balancing or special tools, if you choose to balance your own blades.

C. BLADE REPLACEMENT

WARNING

Always wear proper hand and eye protection when working with cutter blades.

1. Remove the ignition key before replacing the blades.
2. Raise the mower deck to the highest position. Place the lanyard pin in the highest cutting height position to prevent the cutter deck from falling.
3. Secure the cutter blades to prevent them from rotating, (use the optional Blade Buddy tool P/N 9212, to assist in securing the cutter blades), remove the blade attaching bolt. Remove the cutter blade, bolt, lockwasher and flatwasher from the spindle shaft. See Figure 7-9.

CAUTION

Inspect the cutter blade spacer(s) and washer for wear and/or cupping. Replace the worn parts. Worn spacer(s) and/or washer will not allow proper tightening of the cutter blade and can lead to cutter blade failure, personal injury or property damage.

- To install the new cutter blade, put the lockwasher and flatwasher onto the blade bolt and slide the bolt into the hole in the cutter blade.

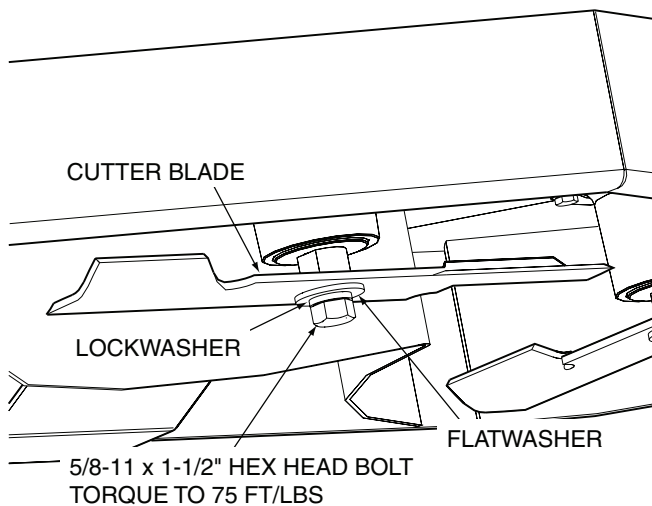

Figure 7-9. Blade Replacement

- NOTE -

Be sure that the blade is installed with the lift wing toward the top.

- Install the cutter blade onto the cutter spindle shaft. Secure the blades from rotating and torque to 75 ft/lbs. See Figure 7-9.

7.9 TIRES

Check the tire pressures after every 8 hours of operation or daily.

Caster Wheels	25 PSI
Drive Wheels	8

7.10 BODY, DECK, AND UPHOLSTERY

CAUTION

Do not wash any portion of the equipment while it is hot. Do not wash the engine; use compressed air.

- After each use, wash the mower and cutter deck. Use cold water and automotive cleaners. Do not use pressure cleaners.
- Do not spray electrical components.
- Use a mild soap solution or a vinyl/rubber cleaner to clean the seat.
- Repair damaged metal surfaces using Scag touch-up paint available from your authorized Scag dealer. Wax the mower for maximum paint protection.

7.11 CASTER PIVOT GREASE PROCEDURE

- Remove grease cap, part number 484195. Remove plug, part number 482028-01.
- Install grease zerk. Apply grease (chassis grease p/n 486257) to the fitting until new grease appears at the top of the caster extension.
- Remove the grease zerk and reinstall the plug.
- Reinstall the grease cap. special tool, part number 47007, is recommended for use in the installation of the grease cap.

ILLUSTRATED PARTS LIST

8.1 SCAG APPROVED ATTACHMENTS AND ACCESSORIES.

Attachments and accessories manufactured by companies other than Scag Power Equipment are not approved for use on this machine.

Scag approved attachments and accessories:

- GC-SZL/SFZ/SPZ (p/n 901K, requires p/n 901H or 901J Install Kit)
- GC-2B (Blower Driven)(p/n 901G, requires p/n 901H or 901J Install Kit)
- Mulch Plate (p/n 9299, 920U)
- Hurricane Mulch (p/n 9294, 920T)
- SZL/SFZ/SPZ/STT/STTII Hitch (p/n 9242)
- GC-F4 (p/n 9075)
- Blade Buddy (p/n 9212)
- SFZ/SPZ Lights (LED p/n 924A)
- 12" Chrome Wheel Covers (set of 2) (p/n 920J)
- Flat Free Tires (p/n 9277 or 9278)
- SPZ Striper (923F) - Requires Install Kit 921T

Scag Premium Lubricants:

- Chassis Grease (p/n 486257)
- 20W50 Oil - Gallon (p/n 486254)
- 20W50 Oil - Quart (p/n 486255)

NOTES

52H CUTTER DECK

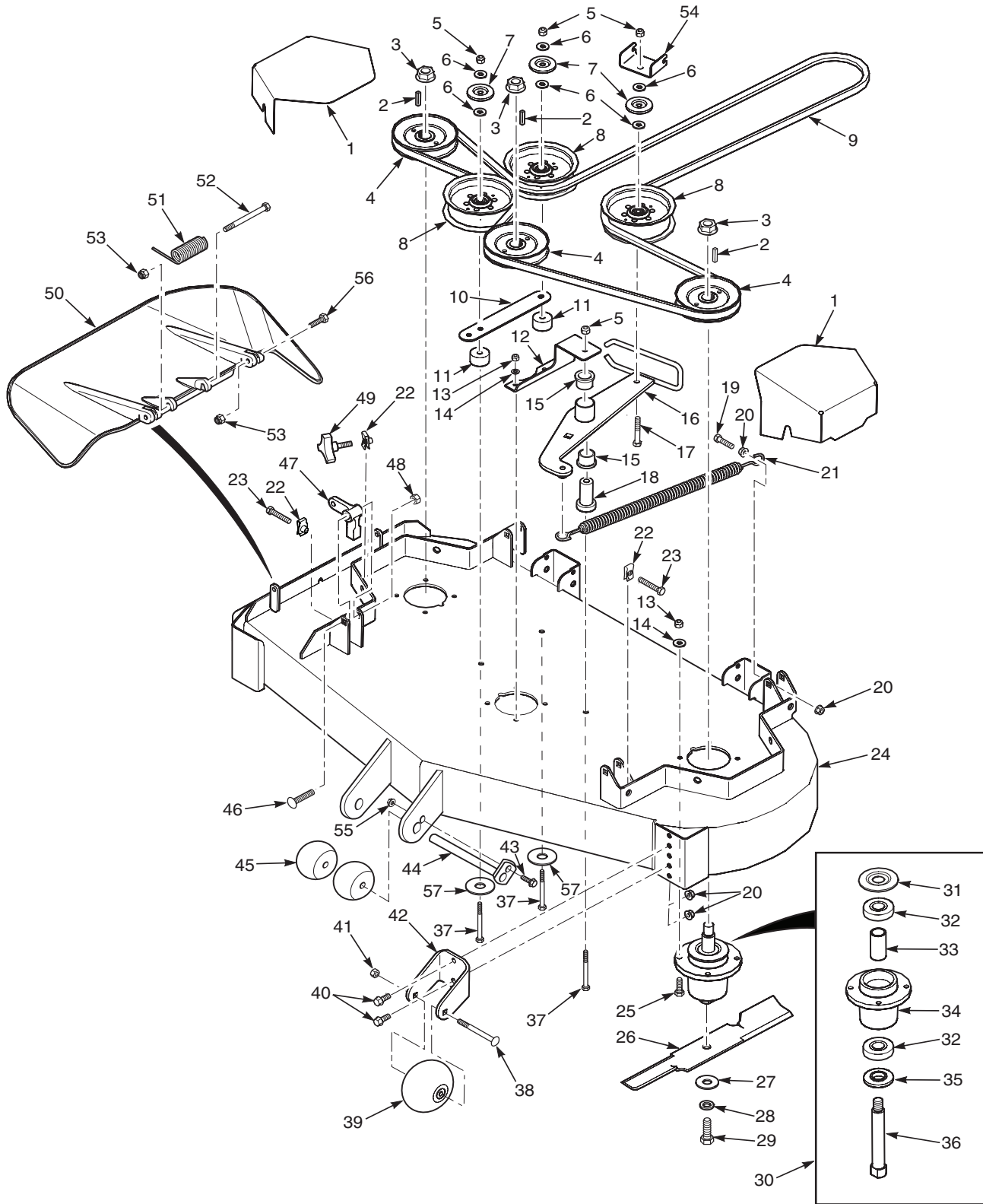

52H CUTTER DECK

	Part No.	Description
1	424528	Belt Cover
2	04063-01	Key, 1/4 x 1/4 x 1-1/4"
3	04112-06	Nut, 3/4-16 Spiral Lock
4	483324	Pulley, 5.73" OD - 25mm Bore
5	04021-09	Nut, Elastic Stop 3/8-16
6	04043-04	Flatwasher, 3/8-.391 x .938 x .105
7	424367	Dust Shield
8	483422	Pulley, 5" Idler
9	483326	Belt, Cutter Deck
10	424479	Brace, Pulley
11	43711	Spacer
12	424547	Support, Idler Pivot
13	04021-22	Nut, Elastic Stop
14	04030-03	Lockwasher, 5/16 Spring
15	483453-03	Bearing
16	462037	Idler Arm (incl. item #15)
17	04001-31	Bolt, Hex Head 3/8-16 x 2-1/2"
18	43708	Pivot, Idler
19	04001-136	Bolt, Hex Head 3/8-16 x 1-1/2 Gr.8
20	04019-04	Nut, Serrated Flange 3/8-16
21	483375	Spring, Idler
22	04110-03	U-Nut, 3/8-16
23	04107-04	Bolt, Hex Head 3/8-16 x 2"Special Lock
24	463308	Cutter Deck w/Decals, SPZ52
25	04001-11	Bolt, Hex Head 5/16-18 x 1-1/2"
26	482878	Cutter Blade, 18"
27	04043-06	Flatwasher, 5/8-.688 x 1.75 x .134 HD
28	04030-07	Lockwasher, 1/2 Spring
29	04001-121	Bolt, Hex Head 5/8-11 x 1-1/2"
30	461950	Spindle Assembly

	Part No.	Description
31	483304	Debris Shield
32	483303	Bearing
33	43693	Spacer
34	462014	Spindle Housing Assembly (Incl. item #32, 33)
35	43694	Protector, Bearing
36	43695	Shaft, Spindle
37	04001-77	Bolt, Hex Head 3/8-16 x 3-1/2"
38	04003-26	Bolt, Carriage 3/8-16 x 4"
39	481632	Wheel, Anti-Scalp
40	04017-27	Bolt, Hex Head 3/8-16 x 1" Ser. Fig.
41	04021-05	Nut, Center Lock 3/8-16
42	427865	Bracket, Anti-Scalp, (Black)
43	04001-09	Bolt, Hex Head 5/16-18 x 1"
44	451926	Shaft Weldment
45	482295	Wheel, Anti-Scalp
46	04003-42	Bolt, Carriage 7/16-14 x 2-1/4"
47	483361	Lever, Deck Level
48	04021-11	Nut, Elastic Stop 7/16-14
49	481625-01	Knob w/Stud
50	462032	Discharge Chute Assy.
*	462474	CA Discharge Chute, 52
51	482245	Spring, Discharge Chute
52	04001-154	Bolt, Hex Head 5/16-18 x 4-3/4"
53	04021-10	Nut, Elastic Stop 5/16-18
54	424615	Bracket, Belt Guide
55	04019-03	Nut, Serrated Flange 5/16-18
56	04001-12	Bolt, Hex Head 5/16-18 x 1-3/4"
57	04041-38	Flatwasher, 3/8-.406 x 2.25 x .1875
*	424211	Turbo Baffle

* = California Models Only (not shown)

61H CUTTER DECK

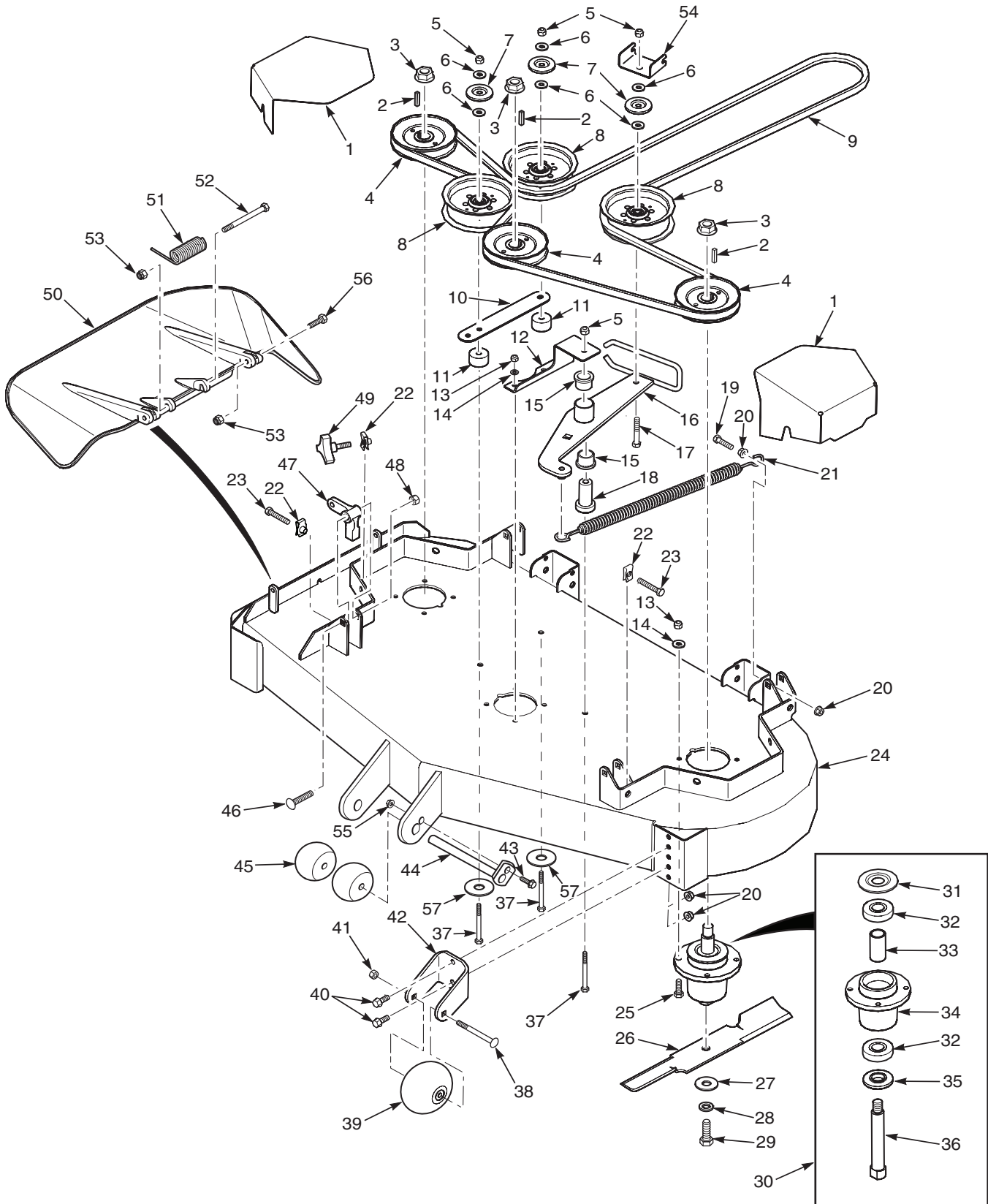

61H CUTTER DECK

	Part No.	Description
1	425260	Belt Cover
2	04063-01	Key, 1/4 x 1/4 x 1-1/4"
3	04112-06	Nut, 3/4-16 Spiral Lock
4	484026	Pulley, 6.32" OD - 25mm Bore
5	04021-09	Nut, Elastic Stop 3/8-16
6	04043-04	Flatwasher, 3/8-.391 x .938 x .105
7	424367	Dust Shield
8	483422	Pulley, 5" Idler
9	484031	Belt, Cutter Deck
10	424479	Brace, Pulley
11	43711	Spacer
12	425264	Support, Idler Pivot
13	04021-22	Nut, Elastic Stop
14	04030-03	Lockwasher, 5/16 Spring
15	483453-03	Bearing
16	462037	Idler Arm (incl. item #15)
17	04001-31	Bolt, Hex Head 3/8-16 x 2-1/2"
18	43708	Pivot, Idler
19	04001-136	Bolt, Hex Head 3/8-16 x 1-1/2 Gr.8
20	04019-04	Nut, Serrated Flange 3/8-16
21	483375	Spring, Idler
22	04110-03	U-Nut, 3/8-16
23	04107-04	Bolt, Hex Head 3/8-16 x 2" Special Lock
24	463309	Cutter Deck w/Decals, SPZ61
25	04001-11	Bolt, Hex Head 5/16-18 x 1-1/2"
26	482879	Cutter Blade, 21"
27	04043-06	Flatwasher, 5/8-.688 x 1.75 x .134 HD
28	04030-07	Lockwasher, 1/2 Spring
29	04001-121	Bolt, Hex Head 5/8-11 x 1-1/2"
30	461950	Spindle Assembly

	Part No.	Description
31	483304	Debris Shield
32	483303	Bearing
33	43693	Spacer
34	462014	Spindle Housing Assembly (Incl. item #32, 33)
35	43694	Protector, Bearing
36	43695	Shaft, Spindle
37	04001-77	Bolt, Hex Head 3/8-16 x 3-1/2"
38	04003-26	Bolt, Carriage 3/8-16 x 4"
39	481632	Wheel, Anti-Scalp
40	04017-27	Bolt, Hex Head 3/8-16 x 1" Ser. Flg.
41	04021-05	Nut, Center Lock 3/8-16
42	427865	Bracket, Anti-Scalp, (Black)
43	04001-09	Bolt, Hex Head 5/16-18 x 1"
44	451926	Shaft Weldment
45	482295	Wheel, Anti-Scalp
46	04003-42	Bolt, Carriage 7/16-14 x 2-1/4"
47	483361	Lever, Deck Level
48	04021-11	Nut, Elastic Stop 7/16-14
49	481625-01	Knob w/Stud
50	462213	Discharge Chute Assembly
*	462476	CA Discharge Chute, SMFZ-61
51	482245	Spring, Discharge Chute
52	04001-154	Bolt, Hex Head 5/16-18 x 4-3/4"
53	04021-10	Nut, Elastic Stop 5/16-18
54	424615	Bracket, Belt Guide
55	04019-03	Nut, Serrated Flange 5/16-18
56	04001-12	Bolt, Hex Head 5/16-18 x 1-3/4"
57	04041-38	Flatwasher, 3/8-.406 x 2.25 x .1875
*	425867	Turbo Baffle

* = California Models Only (not shown)

CUTTER DECK CONTROLS - SPZ52H

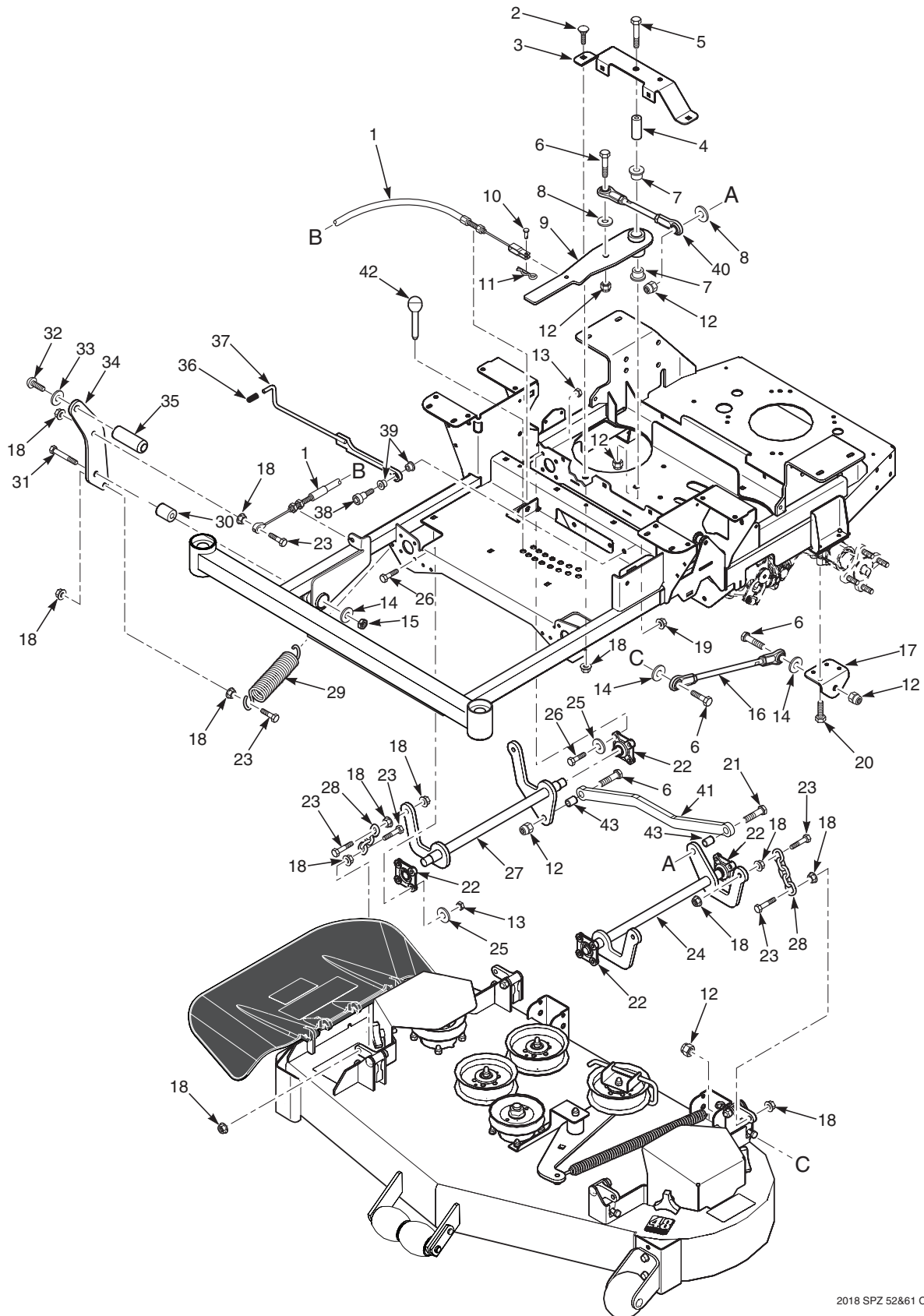

CUTTER DECK CONTROLS - SPZ52H

Ref. No.	Part No.	Description
1	483341	Cable, Deck Lift
2	04003-31	Bolt, Carriage 3/8-16 x 3/4"
3	424476	Support, Idler Arm
4	43710	Spacer, Deck Lift Pivot
5	04001-90	Bolt, Hex Head 1/2-13 x 3-3/4"
6	04001-72	Bolt, Hex Head 1/2-13 x 2"
7	483453-03	Bearing
8	04040-07	Flatwasher, 1/2-.531 x 1.06 x .095
9	462215	Deck Lift Bellcrank Assembly
10	04064-17	Clevis Pin, 5/16 x 3/4"
11	04062-01	Hair Pin, .094 x 1.62"
12	04021-07	Nut, Elastic Stop 1/2-13
13	04021-10	Nut, Elastic Stop 5/16-18
14	04040-13	Flatwasher, 1/2-.562 x 1.375 x .109
15	04021-09	Nut, Center Lock 1/2-13
16	483332	Linkage, Push Arm
17	424489	Bracket, Push Arm Link
18	04019-04	Nut, Serrated Flange 3/8-16
19	04021-09	Nut, Elastic Stop 3/8-16
20	04001-49	Bolt, Hex Head 5/16-18 x 3"
21	04001-74	Bolt, Hex Head 1/2-13 x 3"
22	483334	Bearing, Deck Lift
23	04001-20	Bolt, Hex Head 3/8-16 x 1-1/2"
24	451868	Weldment, Deck Lift LH
25	04040-14	Flatwasher, 1/4-.312 x .750 x .065
26	04001-09	Bolt, Hex Head 5/16-18 x 1"
27	451867	Weldment, Deck Lift RH
28	482628	Chain, Deck Lift
29	483374	Spring, Deck Lift
30	43710	Sleeve, Deck Lift Pivot
31	04001-74	Bolt, Hex Head 1/2-13 x 3"
32	04105-01	Bolt, Head Socket 5/8-11 x 1-1/2"
33	04030-07	Lockwasher, 5/8 Spring
34	424535	Pedal, Foot Bracket
35	424504	Foot Pedal
36	483492	Grip, Deck Latch
37	491254	Weldment, Deck Latch
38	04009-06	Bolt, Shoulder 1/2 x 1/2
39	483453-10	Bearing
40	483328	Linkage Assembly, Deck Lift
41	426579	Link, Deck Lift
42	483498	Pin, Height Adjuster
43	43957	Sleeve

CUTTER DECK CONTROLS - SPZ61H

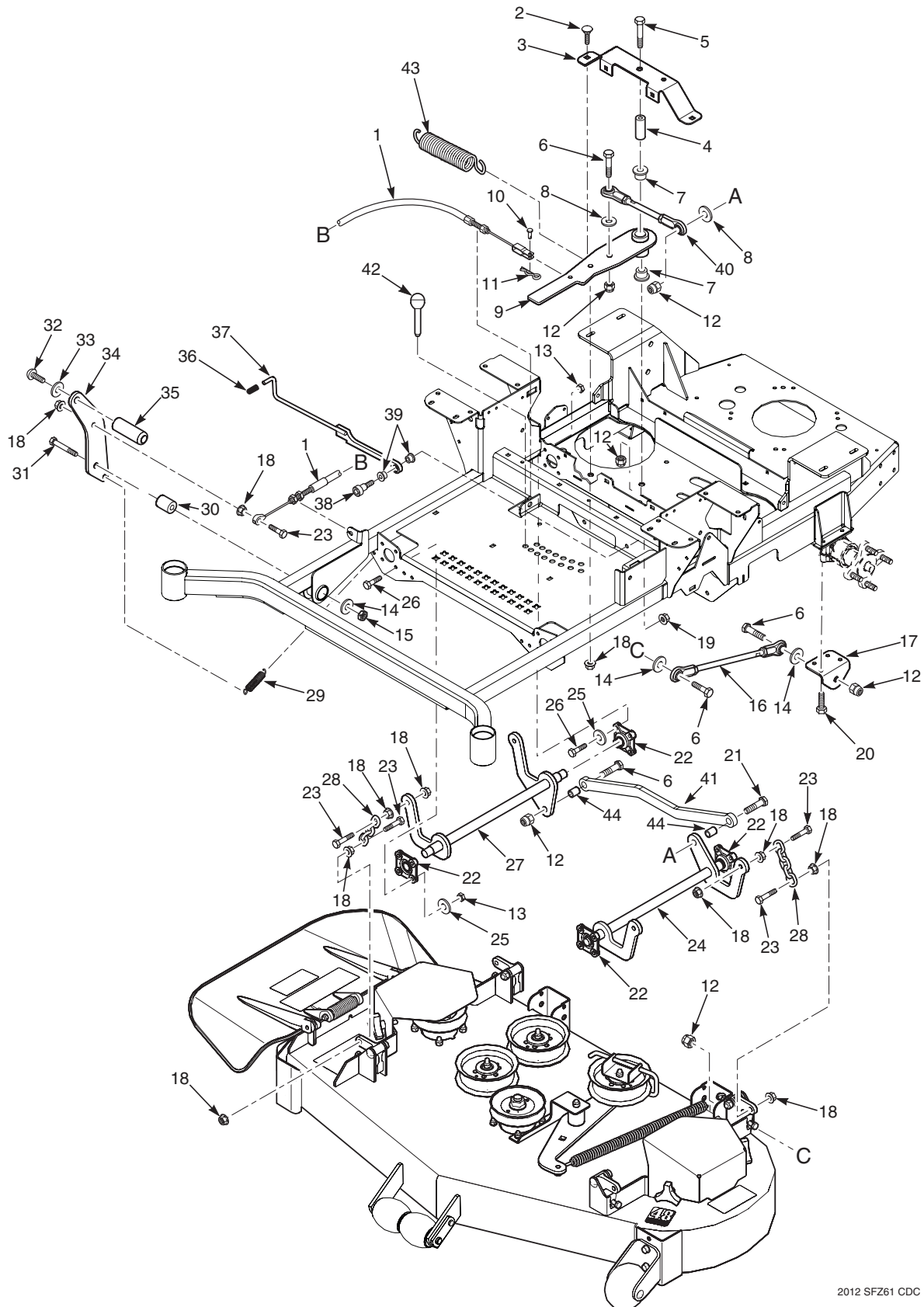

2012 SFZ61 CDC

CUTTER DECK CONTROLS - SPZ61H

Ref. No.	Part No.	Description
1	483341	Cable, Deck Lift
2	04003-31	Bolt, Carriage 3/8-16 x 3/4"
3	424476	Support, Idler Arm
4	43710	Spacer, Deck Lift Pivot
5	04001-90	Bolt, Hex Head 1/2-13 x 3-3/4"
6	04001-72	Bolt, Hex Head 1/2-13 x 2"
7	483453-03	Bearing
8	04040-07	Flatwasher, 1/2-.531 x 1.06 x .095
9	462215	Deck Lift Bellcrank Assembly
10	04064-17	Clevis Pin, 5/16 x 3/4"
11	04062-01	Hair Pin, .094 x 1.62"
12	04021-07	Nut, Elastic Stop 1/2-13
13	04117-01	Nut, Elastic Stop Flange 5/16-18
14	04040-13	Flatwasher, 1/2-.562 x 1.375 x .109
15	04021-09	Nut, Center Lock 1/2-13
16	483332	Linkage, Push Arm
17	424489	Bracket, Push Arm Link
18	04019-04	Nut, Serrated Flange 3/8-16
19	04021-09	Nut, Elastic Stop 3/8-16
20	04001-49	Bolt, Hex Head 5/16-18 x 3"
21	04001-74	Bolt, Hex Head 1/2-13 x 3"
22	483334	Bearing, Deck Lift
23	04001-20	Bolt, Hex Head 3/8-16 x 1-1/2"
24	452112	Weldment, Deck Lift LH
25	04040-14	Flatwasher, 1/4-.312 x .750 x .065
26	04001-09	Bolt, Hex Head 5/16-18 x 1"
27	452113	Weldment, Deck Lift RH
28	482628	Chain, Deck Lift
29	484038	Spring, Deck Lift
30	43710	Sleeve, Deck Lift Pivot
31	04001-74	Bolt, Hex Head 1/2-13 x 3"
32	04105-01	Bolt, Head Socket 5/8-11 x 1-1/2"
33	04030-07	Lockwasher, 5/8 Spring
34	424844	Pedal, Foot Bracket
35	424504	Foot Pedal
36	483492	Grip, Deck Latch
37	491254	Weldment, Deck Latch
38	04009-06	Bolt, Shoulder 1/2 x 1/2
39	483453-10	Bearing
40	483328	Linkage Assembly, Deck Lift
41	426579	Link, Deck Lift
42	483498	Pin, Height Adjuster
43	483374	Spring, Deck Lift
44	43957	Sleeve

SHEET METAL COMPONENTS - SPZ

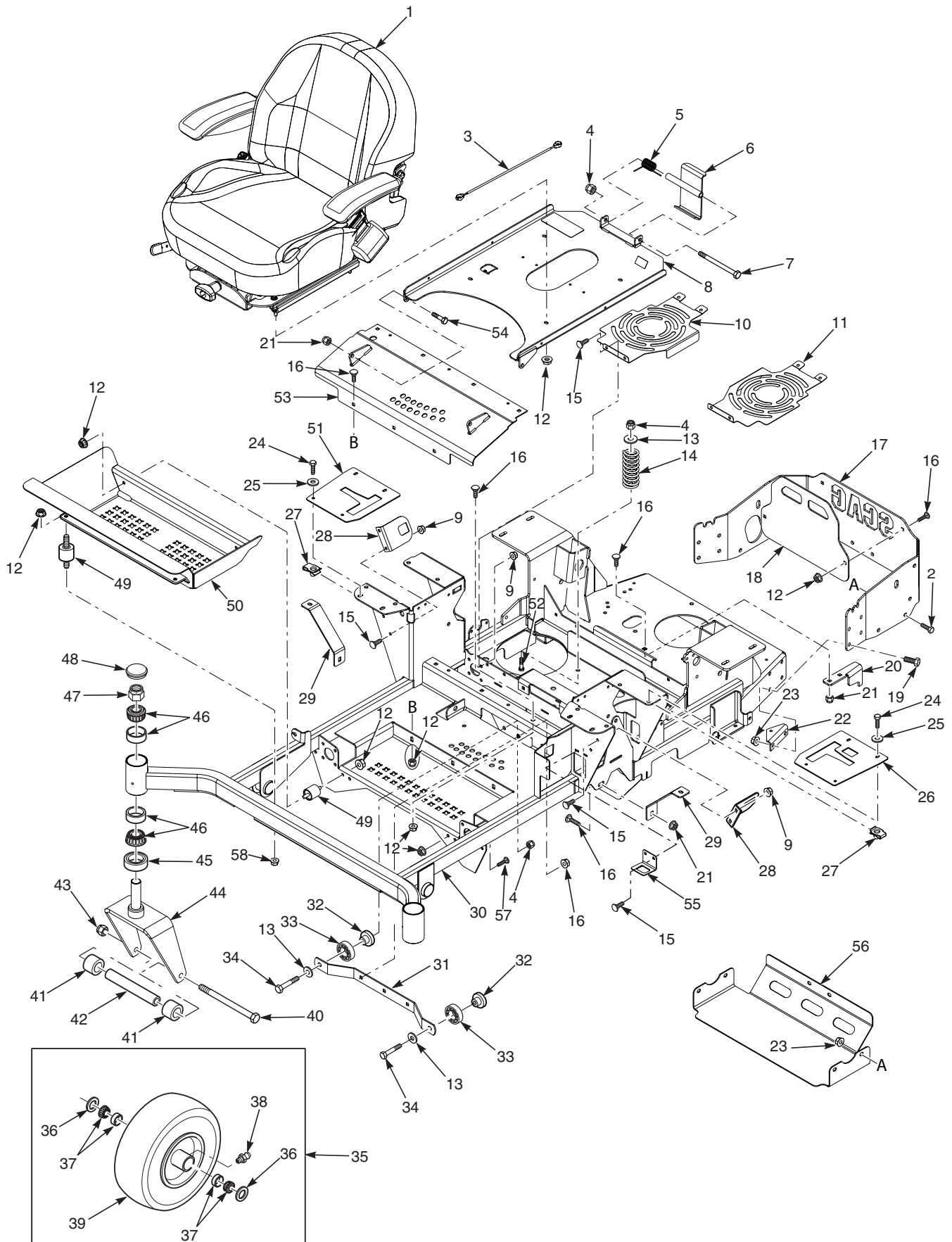

SHEET METAL COMPONENTS - SPZ

	Part No.	Description	Ref. No.	Part No.	Description
1	486545	Seat Assembly	36	482622	Seal
2	04017-27	Bolt, Hex Head 3/8-16 x 1"	37	482621	Bearing
3	483559	Cable, Seat Stop	38	48114-10	Fitting, Grease
4	04021-09	Nut, Elastic Stop 3/8-16	39	482619	Tire, 13 x 6.5-6
5	483371	Spring, Seat Latch		486295	Rim, (Black)
6	451883	Weldment, Seat Latch	40	04001-167	Bolt, Hex Head 1/2-13 x 9-1/2"
7	04001-100	Bolt, Hex Head 3/8-16 x 6"	41	43584	Spacer, Caster Wheel
8	462998	Seat Plate Weldment	42	43583	Sleeve, Caster Wheel
9	04019-02	Nut, Serrated Flange 1/4-20	43	04021-07	Nut, Elastic Stop 1/2-13
10	428503	Fan Cover, RH	44	453007	Yoke Weldment, (Black)
11	428502	Fan Cover, LH	45	481025	Seal, 2" OD x 1.625 ID
12	04019-03	Nut, Serrated Flange 5/16-18	46	48668	Bearing Set
13	04041-07	Flatwasher, 3/8-.391 x .938 x .105	47	04021-20	Nut, Elastic Stop 1"-14
14	483372	Spring, Seat	48	484195	Grease Cap
15	04003-07	Bolt, Carriage 1/4-20 x 1/2"	49	483493	Rubber Isolator
	04001-59	Bolt, Hex Head 1/4-20 x 1-1/4" (Fan Cover Spring Anchor)	50	453003	Footplate Weldment, (Black) - SPZ52H
16	04003-12	Bolt, Carriage 5/16-18 x 3/4"		453004	Footplate Weldment, (Black) - SPZ61H
	04001-09	Bolt, Hex Head 5/16-18 x 1" (Front Hole)	51	463169	Control Plate w/Decal, RH (Black)
17	427863	Bumper, (Black)	52	04003-11	Bolt, Carriage 3/8-16 x 1-1/4"
18	427862	Guard, Engine, (Scag Gold)	53	463108	Deck Lift Cover w/Decal, - SPZ52H
19	04001-19	Bolt, Hex Head 3/8-16 x 1"		463109	Deck Lift Cover w/Decal, - SPZ61H
20	425696	Anti-Rotation Bracket	54	04017-27	Bolt, Hex Head Flange 3/8-16 x 1"
21	04021-09	Nut, Elastic Stop 3/8-16	55	425889	Switch Bracket
22	424639	Bracket, Dump Valve	56	427864	Heat Shield, (Scag Gold)
23	04019-04	Nut, Serrated Flange 3/8-16		427123	Heat Shield, (Black)
24	04017-06	Bolt, Hex Head 1/4-20 x 1"	57	04001-09	Bolt, Hex Head, 5/16-18 x 1"
25	04040-14	Flatwasher, 1/4-.312 x .750 x .065	58	04117-01	Nut, Elastic Stop Flange, 5/16-18
26	463168	Control Plate w/Decal, LH (Black)			
27	04110-01	U-Nut, 1/4-20			
28	424511	Bracket, Switch Mount			
29	425890	Bracket, Tank Mount, SPZ52H			
	425700	Bracket, Tank Mount, SPZ61H			
30	463317	Mainframe Assy., w/Decals (Black) - SPZ52H			
	463318	Mainframe Assy., w/Decals (Black)- SPZ61H			
31	424480	Support, Deck Guide			
32	43703	Spacer, Bearing			
33	483379	Bearing			
34	04001-31	Bolt, Hex Head 3/8-16 x 2-1/2"			
35	486294	Wheel Assembly, (Black)			

SPZ SUSPENSION SEAT

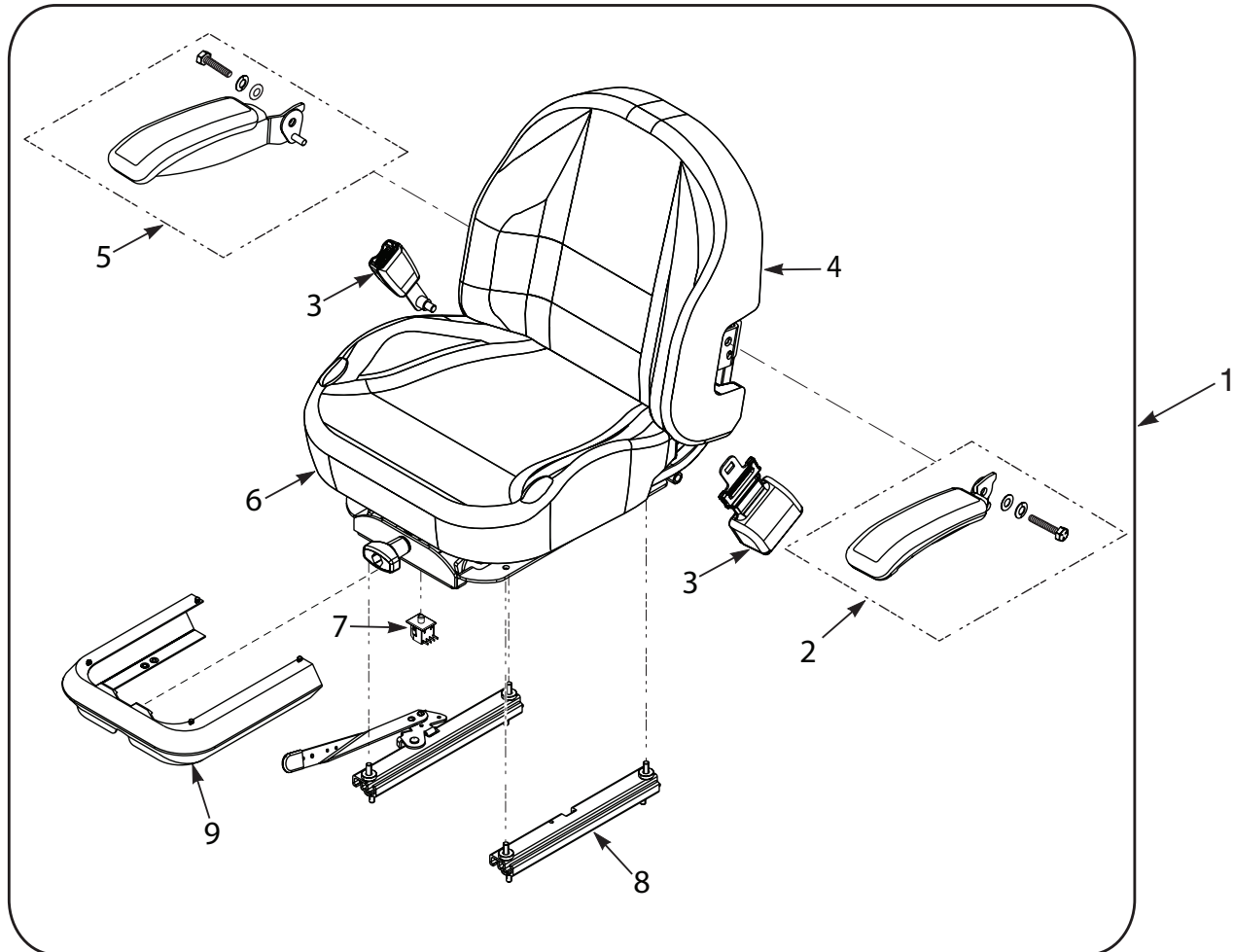

Ref. No.	Part No.	Description
1	486545	Seat Assembly
2	486003	Armrest Kit, LH
3	486546	Seatbelt Kit
4	486595	Back Cover
5	486004	Armrest Kit, RH
6	486594	Cushion Cover
7	483473	Switch
8	486547	Track Set
9	486548	Bellows, Seat

NOTES

BRAKE COMPONENTS - SPZ

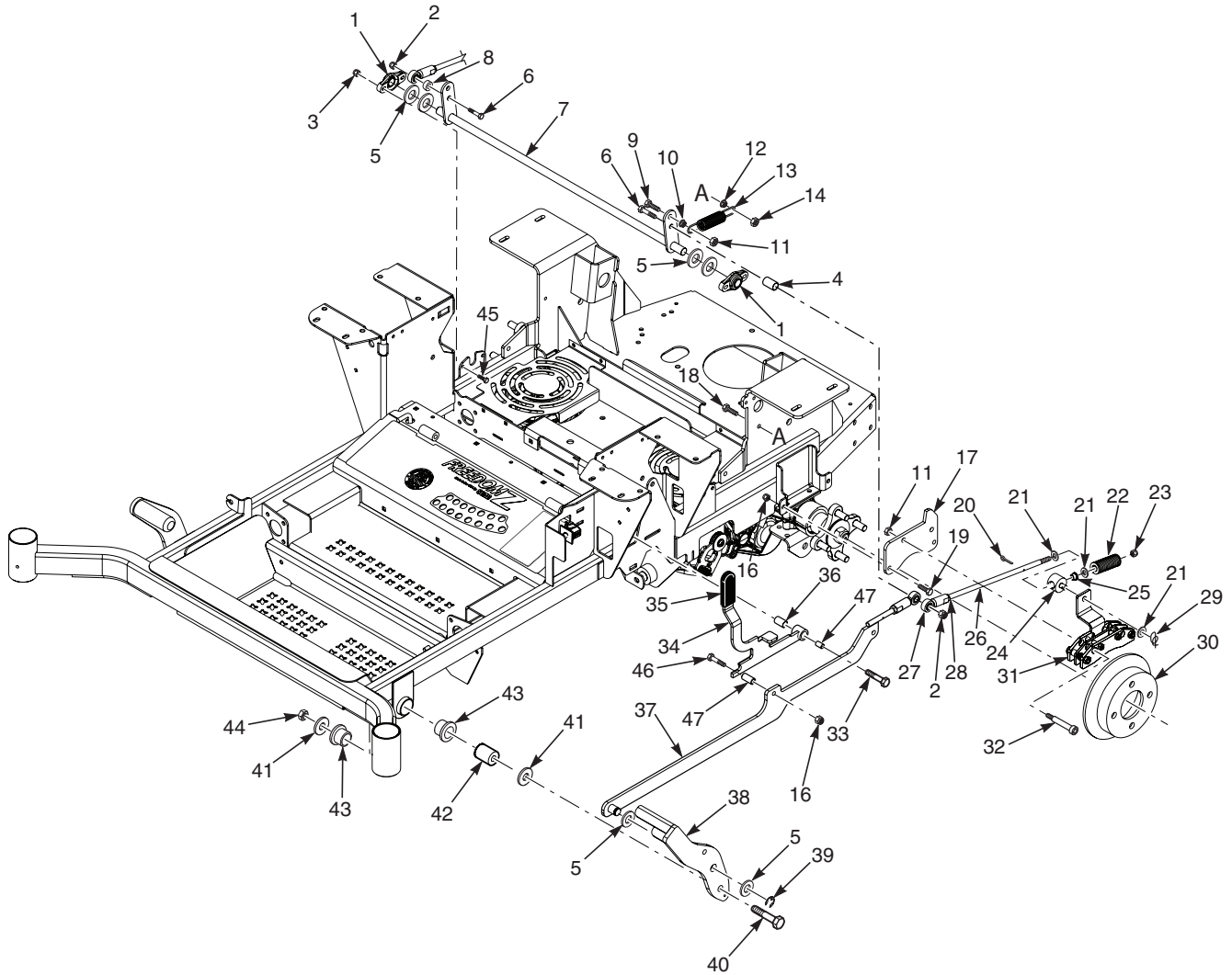

BRAKE COMPONENTS - SPZ

Ref. No.	Part No.	Description
1	483504	Bearing
2	04021-09	Nut, Elastic Stop 3/8-16
3	04117-03	Nut, Elastic Stop 1/4-20
4	43720	Spacer
5	04040-09	Flatwasher, 5/8-.656 x 1.312 x .095
6	04001-46	Bolt, Hex Head 3/8-16 x 2-1/4"
7	452269	Weldment, Brake Lever
8	43674	Spacer
9	04001-20	Bolt, Hex Head 3/8-16 x 1-1/2"
10	04019-04	Nut, Serrated Flange 3/8-16
11	04021-05	Nut, Center Lock 3/8-16
12	04019-03	Nut, Serrated Flange 5/16-18
13	484038	Spring
14	04021-04	Nut, Center Lock 5/16-18
15	04041-07	Flatwasher, 3/8-.391 x .938 x .105
16	04021-10	Nut, Elastic Stop 5/16-18
17	425680	Mounting Bracket, Brake
18	04001-09	Bolt, Hex Head 5/16-18 x 1"
19	04001-09	Bolt, Hex Head 5/16-18 x 1"
20	04061-02	Cotter Pin, 3/32 x 3/4"
21	04040-05	Flatwasher, 3/8-.406 x .812 x .065
22	484535	Spring, Brake
23	04021-18	Nut, Elastic Stop 3/8-24
24	462452	Swivel Assembly, Brake
25	483453-23	Bearing
26	04004-54	Link, Brake
27	482330	Rod End
28	04020-25	Nut, 3/8-24 UNF Jam
29	04069-01	Pin, Rue Cotter - 3/8" Dia.
30	43853	Brake Hub
31	483701	Brake Caliper
32	04009-17	Bolt, Shoulder 1/2 x 2-1/2"
33	04009-16	Bolt, Shoulder 1/2 x 2"
34	462485	Latch Assembly, Brake (incl. # 35, #36)
35	482102	Grip, Brake Lever
36	483453-22	Bearing
37	462419	Linkage Weldment Assembly, Brake
38	452922	Brake Pedal Weldment
39	04050-01	Retaining Ring, .625 Ext. "E"
40	04001-74	Bolt, Hex Head 1/2-13 x 3"
41	04040-13	Flatwasher, 1/2-.562 x 1.375 x .109
42	43710	Sleeve
43	483453-03	Bearing
44	04021-19	Nut, Center Lock 1/2-13
45	04017-06	Bolt, Hex Head 1/4-20 x 1"
46	04001-12	Bolt, Hex Head 5/16-18 x 1-3/4"
47	43866	Sleeve, Handle Pivot

SPZ ROLL-OVER PROTECTION SYSTEM

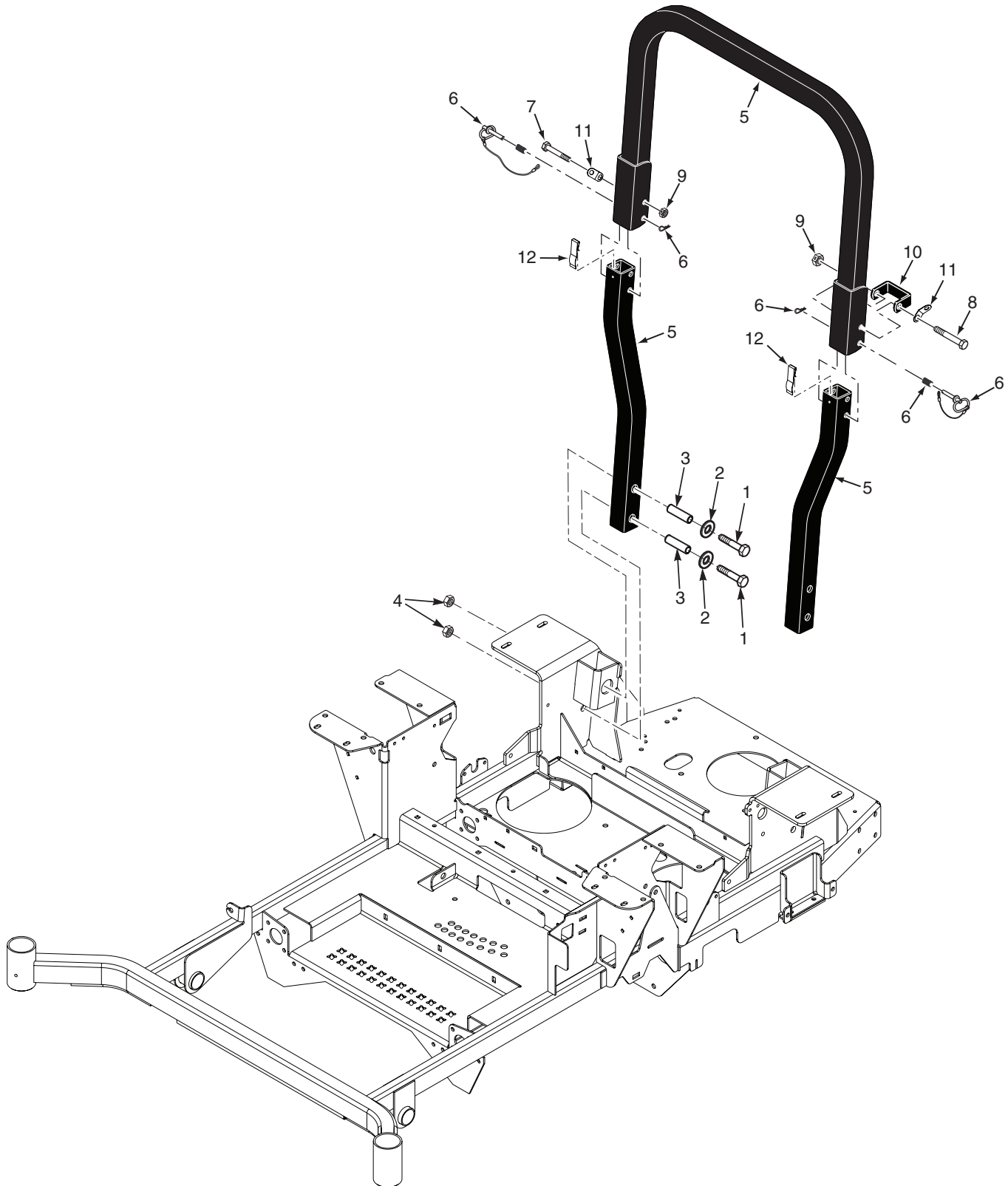

SPZ ROLL-OVER PROTECTION SYSTEM

Ref. No.	Part No.	Description
1	04001-197	Bolt, Hex Head 1/2 13 x 3" Gr. 8
2	04040-07	Flatwasher, 1/2 - .531 x 1.062 x .095
3	43743	Bushing, ROPS
4	04117-04	Nut, Flanged Elastic Stop, 1/2-13
5	463110	ROPS, (Scag Gold)
6	484168	Pin Assembly, ROPS Hinge
7	04001-90	Bolt, Hex Head 1/2-13 x 3-1/4"
8	04001-145	Bolt, Hex Head 1/2-13 x 3-1/2"
9	04021-19	Nut, 1/2-13 Center Lock
10	485722	Stop, ROPS
11	484169	Clip, ROPS
12	484167	Spring, ROPS

DRIVE SYSTEM COMPONENTS - SPZ52 & SPZ61

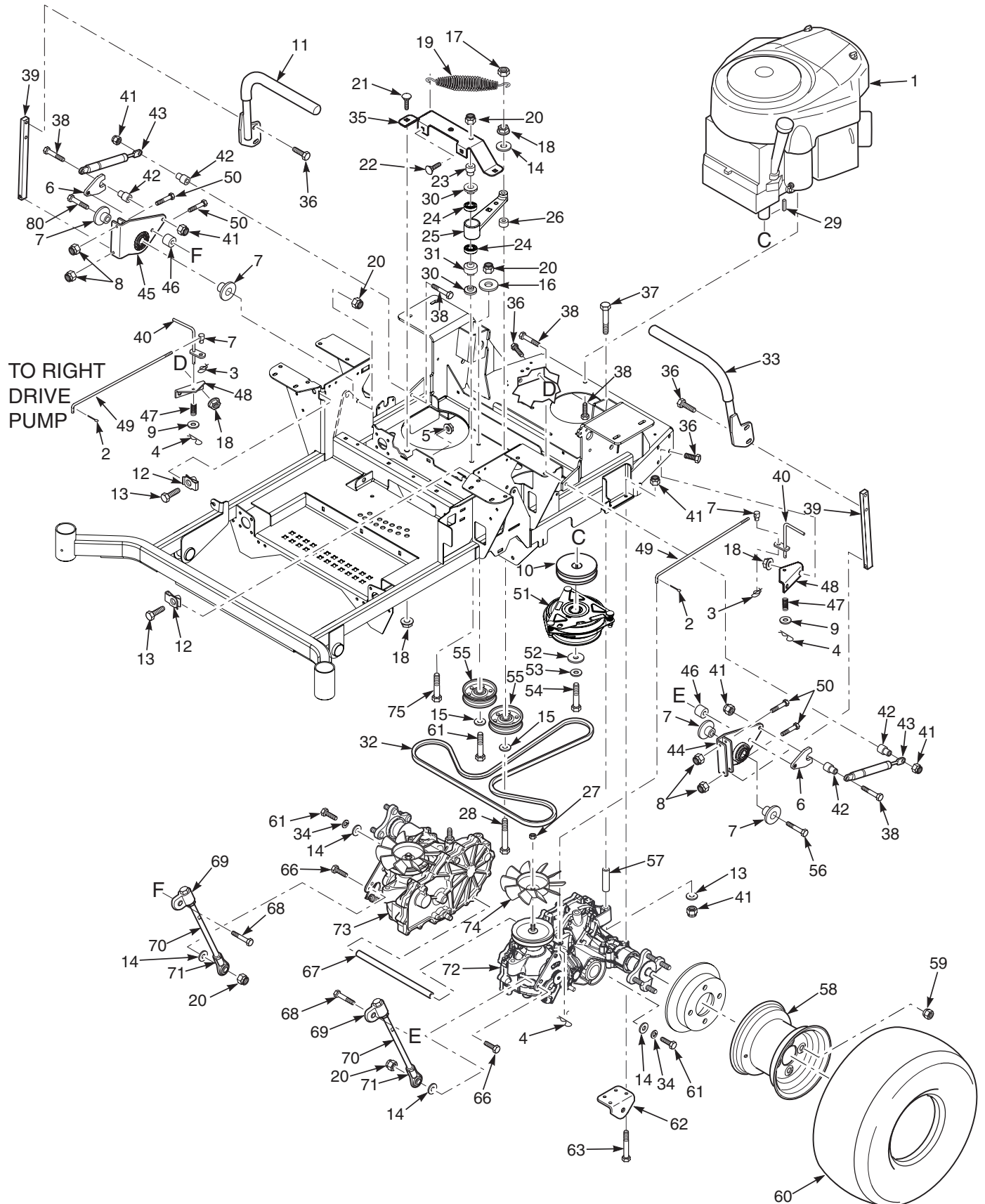

DRIVE SYSTEM COMPONENTS - SPZ52 & SPZ61

Ref. No.	Part No.	Description
1	485706*	Engine, Kawasaki - 22FX
	485707*	Engine, Kawasaki - 23FX
	486137*	Engine, Kohler - 23CV
	486138*	Engine, Kohler - 25CV
2	04061-01	Cotter Pin, 3/32 x 1"
3	04069-01	Pin, Rue Cotter 3/8" Dia.
4	04062-02	Hair Pin, .080 x 1.19"
5	04019-03	Nut, Serrated Flange 5/16-18
6	424687	Nut, Control Link
7	43719	Spacer, Linkage
8	04021-08	Nut, Elastic Stop 1/4-20
9	04040-14	Flatwasher, 1/4-.312 x .750 x .065
10	484646	Pulley, 4-1/2" OD - 1.125 Bore (SPZ52H)
	484373	Pulley, 5" OD - 1.125 Bore (SPZ6H)
11	462434	Handle Bar w/Grip
	484376	Grip
12	04110-03	U-Nut, 3/8-16
13	04107-01	Bolt, Hex Head 3/8-16 x 1-1/4" Special Lock
14	04041-07	Flatwasher, 3/8-.391 x .938 x .105
15	04043-04	Flatwasher, 3/8-.391 x .938 x .105 HD
16	04041-11	Flatwasher, 3/8-.406 x 1.5 x 7 GA.
17	04021-05	Nut, Center Lock 3/8-16
18	04019-04	Nut, Serrated Flange 3/8-16
19	483087	Spring, Transmission Idler
20	04021-09	Nut, Elastic Stop 3/8-16
21	04003-31	Bolt, Carriage 3/8-16 x 3/4"
22	04003-12	Bolt, Carriage 5/16-18 x 3/4"
23	43715	Shaft Pivot, Idler Arm
24	48224	Bearing
25	463017	Trans. Idler Arm Assy. (Includes 24, 79)
26	43674	Spacer, Idler Pulley - SPZ52H
	43720	Spacer, Idler Pulley - SPZ61H
27	*	Fan Nut (order through Hydro-Gear)
28	483438	Reservoir Assembly
29	04063-24	Key, 1/4 x 1/4 x 2-3/4" - Kawasaki
	04063-03	Key, 1/4 x 1/4 x 2-1/5" - Kohler
30	431049	Pivot Idler
31	431073	Spacer, Bearing
32	483314	Belt, Transmission Drive - SPZ52H
	484372	Belt, Transmission Drive - SPZ61H
33	462433	Handle Bar Assembly, w/Grip
	484376	Grip
34	04030-04	Lockwasher, 3/8" Spring
35	424476	Support, Idler Arm
36	04017-27	Bolt, Hex Head 3/8-16 x 1"
37	04001-95	Bolt, Hex Head 5/16-18 x 5"
38	04001-11	Bolt, Hex Head 5/16-18 x 1-1/2"
	04017-15	Bolt, Hex Head 5/16-18 x 1/2" (ground)
39	424498	Bar, Control Lever
40	451912	Dump Valve Lever
41	04021-10	Nut, Elastic Stop 5/16-18
42	43602	Spacer, Pump Dampener
43	484151	Dampener
44	462127	Control Link, LH
45	462128	Control Link, RH
46	43674	Spacer
47	482070	Spring
48	424639	Bracket, Dump Mounting

Ref. No.	Part No.	Description
49	44162	Linkage, Dump Valve
50	04001-04	Bolt, Hex Head 1/4-20 x 1-1/2"
51	462228	Electric Clutch Assembly
52	04041-28	Flatwasher, 7/16-.469 x 1.75 x .25
53	04041-28	Lockwasher, 7/16" spring
54	04102-08	Bolt, Hex Head 7/16-20 x 1-1/2" Patch SPZ61H
	04102-01	Bolt, Hex Head 7/16-20 x 1-3/4" - Kohler
55	486045	Pulley, 3-1/2" Dia.
56	04001-45	Bolt, Hex Head, 3/8-16 x 2"
57	43700	Spacer, Axle - SPZ52H
	43857	Spacer, Axle - SPZ61H
58	485945	Rim w/Valve Stem, (Scag Gold) - SPZ52H
	486289	Rim w/Valve Stem, (Black) - SPZ52H
	482414	Rim w/Valve Stem, (Scag Gold) - SPZ61H
	486292	Rim w/Valve Stem, (Black) - SPZ61H
59	04028-02	Wheel Nut, 1/2-20
60	485944	Tire/Rim Assy, (Scag Gold) 22 x 10.5-12 (SPZ52)
	486288	Tire/Rim Assy, (Black) 22 x 10.5-12 (SPZ52)
	485946	Tire, 22 x 10.5-12 (SPZ52)
	485952	Tire/Rim Assy, (Scag Gold) 24 x 12-12 (SPZ61)
	486291	Tire/Rim Assy, (Black) 24 x 12-12 (SPZ61)
	485953	Tire, 24 x 12-12 (SPZ61)
61	04001-31	Bolt, Hex Head 3/8-16 x 2-1/2"
62	424489	Bracket, Pusharm Link
63	04001-49	Bolt, Hex Head 5/16-18 x 3"
64	*	Clip, Brake Lever (order through Hydro-Gear)
65	*	Lever, Brake (order through Hydro-Gear)
66	04001-20	Bolt, Hex Head 3/8-16 x 1-1/2"
67	43701	Spacer, Axle
68	04001-45	Bolt, Hex Head 3/8-16 x 2"
69	483563	Rod End, Adjustable 3/8-24
	04020-25	Nut, Jam 3/8-24 UNF RH
70	483668	Linkage, Pump - SPZ52H
	484405	Linkage, Pump - SPZ61H
71	483575	Stake, Rod End Assembly
72	486722	Transaxle Assy., LH (ZL-GCEC-SLKF-1NTX) SPZ52H
	486724	Transaxle Assy., LH (ZY-GCEE-SL7F-11TX) SPZ61H
73	486723	Transaxle Assy., RH (ZL-KCEC-SLKG-1NTX) SPZ52H
	486725	Transaxle Assy., RH (ZY-KCEE-SL7G-11TX) SPZ61H
	*	Fan (order through Hydro-Gear)
74	04001-62	Bolt, Hex Head 3/8-16 x 3-1/4"

* Not available through Scag.

EXHAUST AND ELECTRICAL SYSTEM - SPZ

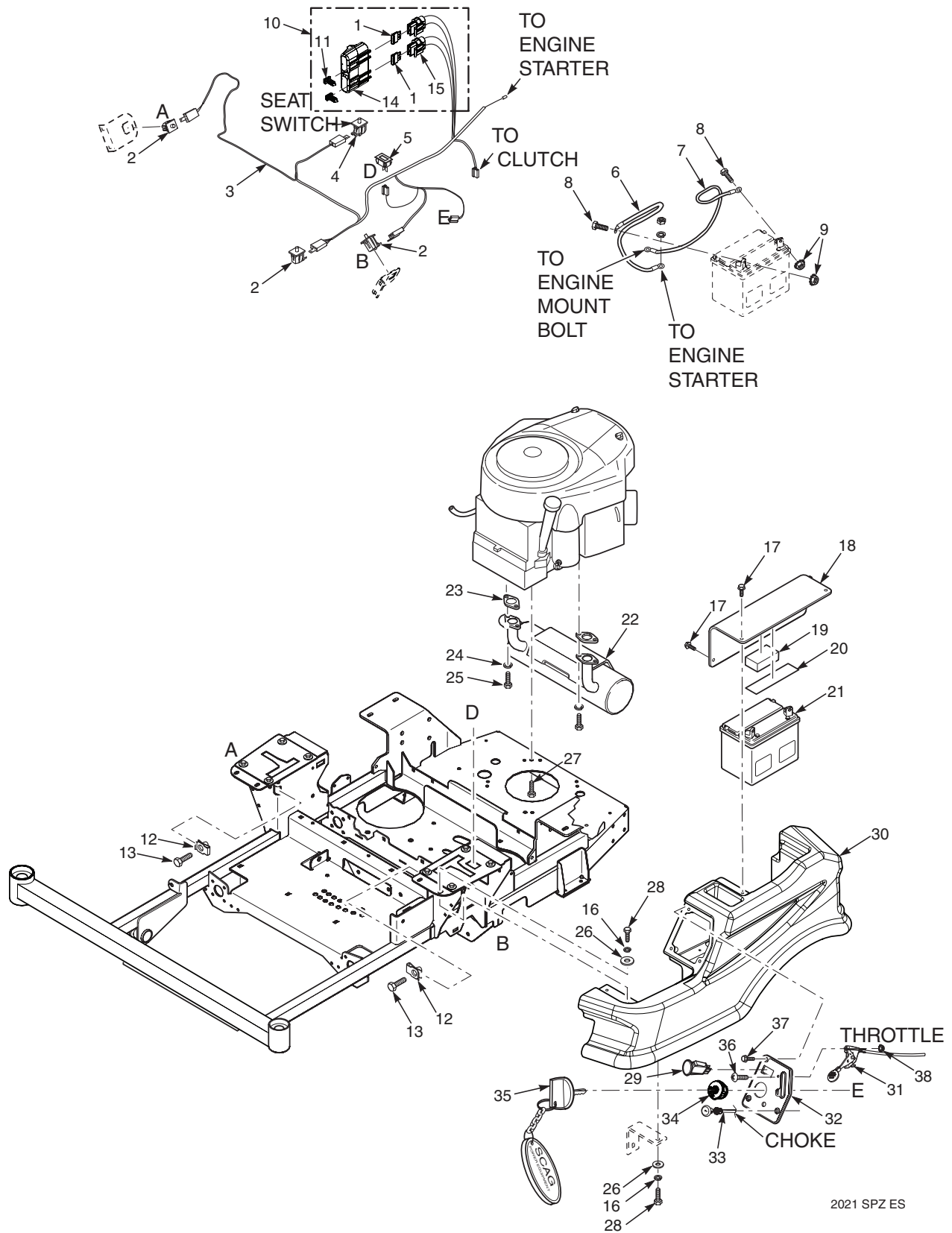

2021 SPZ ES

EXHAUST AND ELECTRICAL SYSTEM - SPZ

Ref. No.	Part No.	Description
1	48298	Fuse, 20 amp
2	483473	Switch
3	486123	Wire Harness, Main
	483529	Wire Harness Adapter, Kawasaki (not shown)
	486134	Wire Harness Adapter, Kohler (not shown)
4	483474	Switch, Seat
5	484565	Hourmeter
6	48029-13	Battery Cable, Red 25"
7	48029-11	Battery Cable, Black 27"
8	04001-44	Bolt, Hex Head 1/4-20 x 1/2"
9	04020-02	Nut, 1/4-20
10	483642	Double Fuse Assy. (incl. items 1, 14, 15, 46)
11	482588	Clip, Wire
12	04110-03	U-Nut, 3/8-16
13	04107-03	Bolt, Hex Head 3/8-16 x 1-1/4" Special Lock
14	483571	Cover, Sealed Double
15	483629	Fuse Holder
16	04030-03	Lockwasher, 5/16" Spring
17	04017-04	Bolt, Hex Head 1/4-20 x 1/2" Serr. Flange
18	463319	Battery Cover (incl. items 19 & 20)
19	485506	Pad, Battery Hold Down
20	483508	Rubber Pad
21	483665	Battery (not avail. through Scag)
22	484209	Muffler Kawasaki
	486141	Muffler, Kohler
23	**	Exhaust Gasket
24	**	Lockwasher
25	**	Bolt
26	04040-15	Flatwasher, 5/16-.375 x .875 x .083
27	04011-07	Bolt, Hex Head 3/8-16 x 1-1/4" - Kohler
	04001-32	Bolt, Hex Head 3/8-16 x 1-1/4" - Kawasaki
	04030-04	Lockwasher, 3/8" Spring - Kawasaki

Ref. No.	Part No.	Description
28	04001-08	Bolt, Hex Head 5/16-18 x 3/4"
29	485833	PTO Switch
30	463304	Console, LH - SPZ
31	483434	Throttle Cable
32	462322	Instrument Panel w/Decal
33	483435	Choke Cable - Kawasaki
	483646	Choke Cable - Kohler
34	483472	Ignition Switch
35	483609	Key w/Shroud
	462069	Key Assembly w/Fob
36	04003-43	Bolt, Carriage, 10-24 x .5
37	04013-01	Screw, Flanged, 5/16-18 x 1/2"
38	04021-26	Nut, Lock, 10-24

** Available through engine manufacturer only.

SPZ FUEL SYSTEM

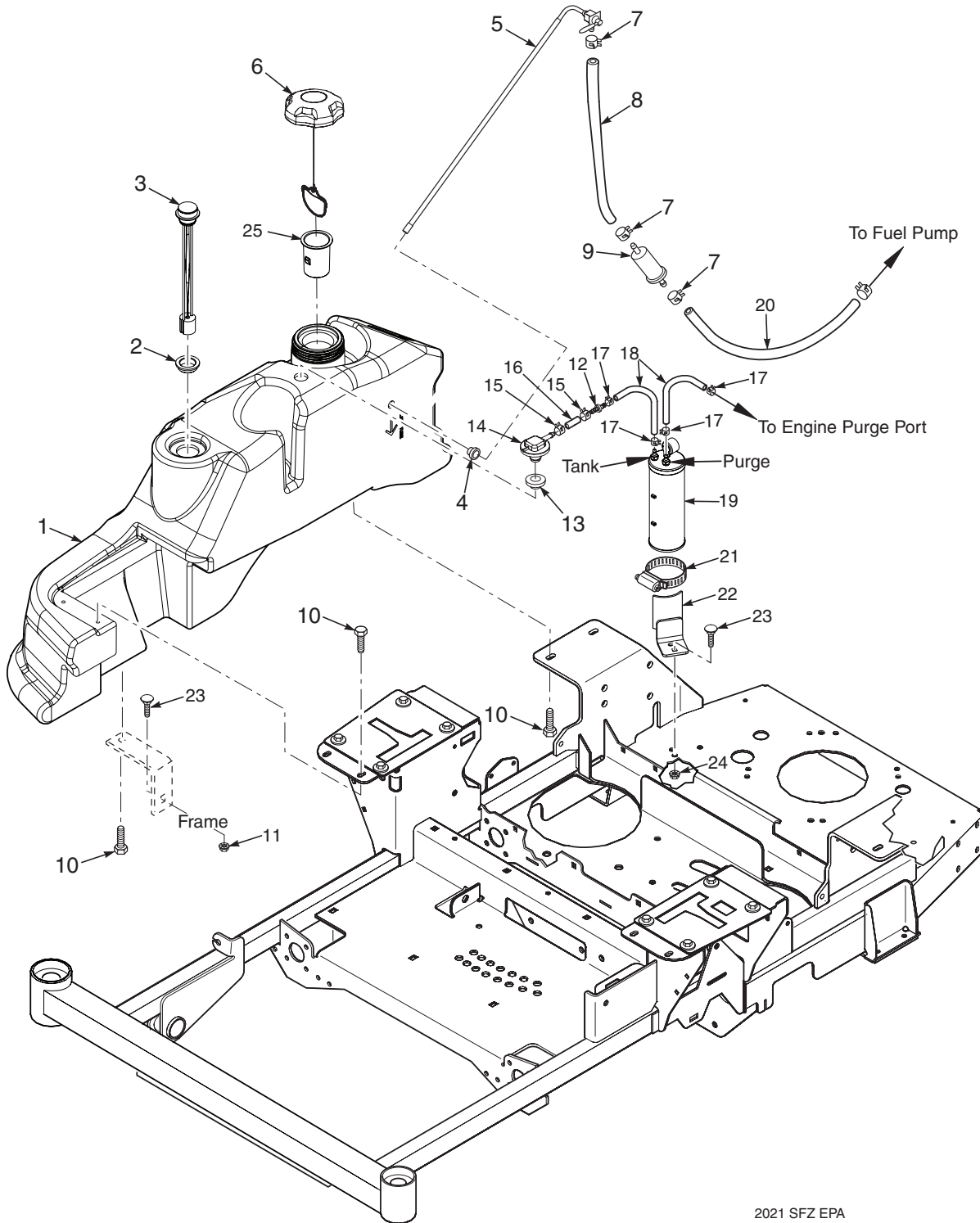

2021 SFZ EPA

SPZ FUEL SYSTEM

Ref. No.	Part No.	Description
1	463305	Fuel Tank Assembly - SPZ (Includes 2,3,4,5,13,14)
2	484242	Grommet, Fuel Gauge
3	484243	Fuel Gauge Assembly
4	482571	Bushing, .56 Dia. Viton
5	483555	Fuel Tube Assembly
6	484286	Fuel Cap, Tethered
	485921	Gasket, Fuel Cap
	484297	Fuel Cap w/Tethered - California Models Only (not shown)
7	48059-01	Clamp, Fuel Hose 1/4"
8	483617	Fuel Hose, 1/4" Non-Perm (order by inch)
9	*	Fuel Filter
10	04017-16	Bolt, Hex Head 5/16-18 x 3/4"
11	04117-01	Nut, Elastic Stop Flange, 5/16-18
12	484343-01	Mender, 1/4 x 3/16 w/0.02 Hole
13	484285	Grommet, Viton
14	484333	Remote Vent
15	48059-02	Clamp, Fuel Hose 7/32"
16	484347	Hose, 1/4" Vapor Recovery (order by inch)
17	48059-05	Clamp, Vapor Recovery Hose
18	484345	Hose, 3/16" (order by inch)
19	484342	Carbon Canister
20	*	Fuel Hose
21	48136-17	Clamp, Hose
22	452226	Bracket Weldment - SPZ52H
	452233	Bracket Weldment - SPZ61H
23	04003-12	Bolt, Carriage 5/16-18 x 3/4"
24	04019-03	Nut, Serrated Flange 5/16-18
25	484279-01	Tube, Fuel Tank Insert

* = Available through engine manufacturer only.

ZT-3100 HYDRAULIC AXLE ASSEMBLY - SPZ52

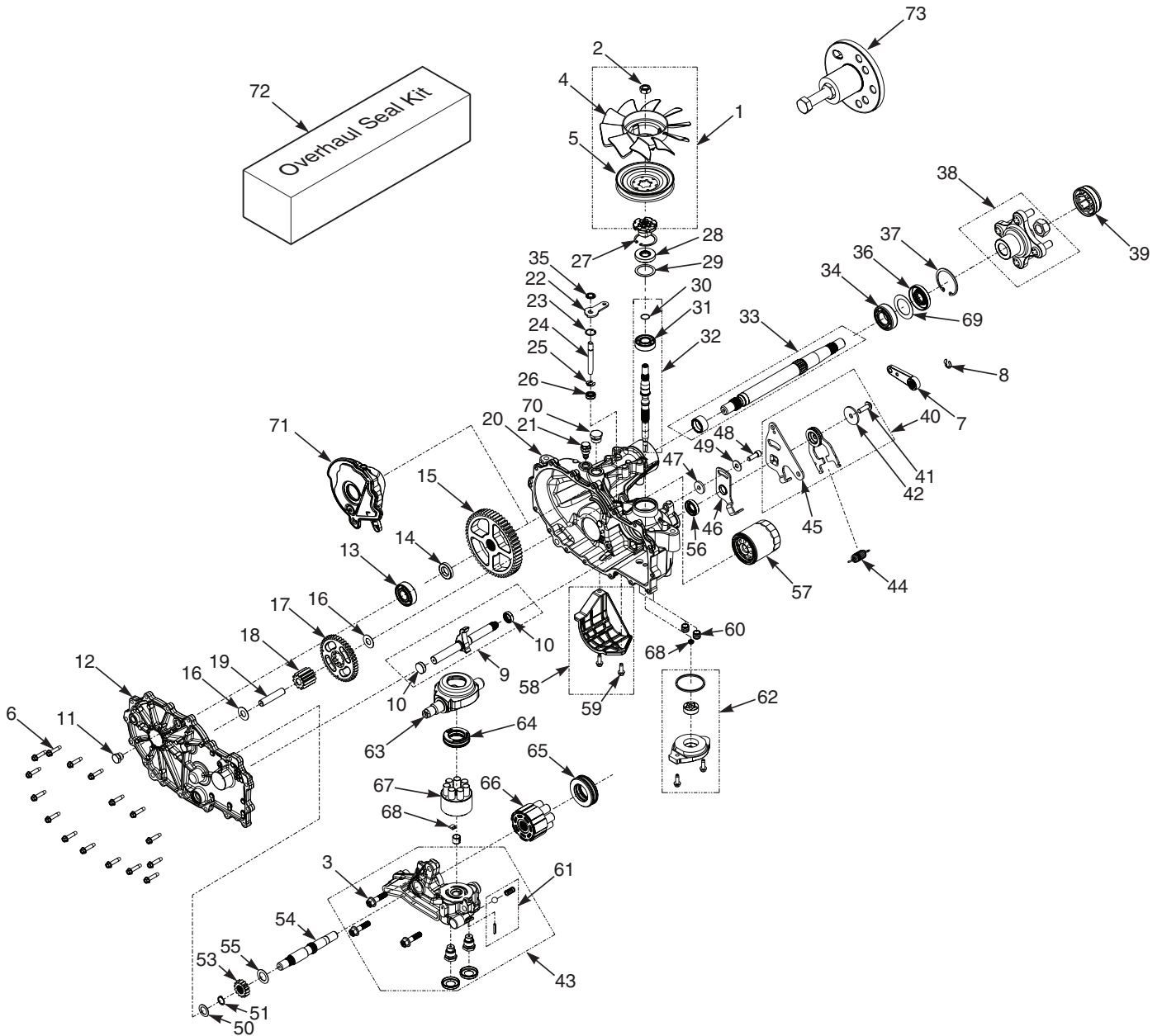

ZT-3100 HYDRAULIC AXLE ASSEMBLY - SPZ52

Ref. No.	Part No.	Description
1	HG72125	Kit, Fan & Pulley
2	HG51244	Nut, Hex Locking 1/2-20
3	HG52137	Bolt, Hex Head 3/8-16 x 1-1/2" Patch
4	HG53823	Fan, 7" Dai. (10 Blade)
5	HG52364	Pulley, Cupped 4-1/2" Dia.
	HG52366	Hub, Pulley
6	HG53246	Bolt, Hex Head 1/4-20 x 1-11/4"
7	HG53973	Handle, Actuating
8	HG53019	Ring, Retaining
9	HG73119	Kit, Outboard LH
	HG73118	Kit Outboard, RH
10	HG51804	O-Ring
11	HG54730	Plug, 9/16-18
12	HG73095	Kit, Side Cover RH
	HG73096	Kit, Side Cover LH
13	HG72749	Bearing, Ball .75 x 40 x 12
14	HG53336	Spacer, .75 x 1.0 x .257
15	HG52108	Gear, 54T
16	HG50132	Washer, .5 x 1.0 x .03
17	HG52110	Gear, 45T
18	HG52586	Gear, 11T
19	HG51083	Jackshaft Pin
20	HG73069	Kit, Housing RH
	HG73073	Kit, Housing LH
21	482800-0371	Fitting
22	HG51629	Arm, By-Pass
23	HG51627	Ring, Retaining .750 Internal
24	HG52136	Rod, By-Pass
25	HG51628	Ring, Retaining .375 External
26	HG55232	Seal, Lip .375 x .75 x .25
27	HG50329	Ring, Retaining 2.06 Internal
28	HG51161	Seal, Lip 17 x 40 x 7
29	HG50951	Washer, 1.23 x 1.56 x .04
30	HG2000022	Ring, Retaining Wire
31	HG50315	Bearing, Ball 17 x 40 x 12 Open
32	HG73047	Shaft, Input
33	HG71569	Shaft Kit, Axle
34	HG53656	Bearing, Ball 1.0 x 52 x 15 Open
35	HG51630	Ring, Retaining .375 External
36	HG53699	Seal, Lip 25 x 52 x 10 TC Gray

Ref. No.	Part No.	Description
37	HG50859	Ring, Retaining 2.06 Internal
38	HG71405	Hub Kit
39	HG53088	Axle Cap
40	HG71595	Kit, RTN Assembly (Does not include #44, 46, 47, 48, 49)
41	HG51812	Bolt, 5/16-24 x 1" Patch
42	HG51950	Washer, .343 x 1.5 x .062
43	HG73265	Kit, Center Section RH
	HG73266	Kit, Center Section LH
44	HG51605	Spring
45	HG52682	Arm, Control
46	HG51945	Arm, Neutral RH
	HG51946	Arm, Neutral LH
47	HG54315	Spacer, .320 x 1.005 x .179
48	HG51616	Bolt, 5/16-24 x 1" Patch
49	HG44130	Washer, .34 x .88 x .06
50	HG44371	Washer, .63 x 1.0 x .05
51	HG44145	Ring, Retaining
52	HG52641	Pawl, Brake
53	HG52341	Gear, 14T
54	HG52150	Shaft, Motor
55	HG51069	Washer, .72 x 1.16 x .04
56	HG51140	Seal, Lip 18 x 32 x 7
57	HG52114	Filter
58	HG71854	Filter Guard
59	HG50752	Bolt, 1/4-20 x 3/4"
60	HG54501	Tube, Charge Triple O ring
61	HG71436	Kit, Charge Relief
62	HG72274	Kit, Charge Pump
63	HG51048	Trunnion Swashplate
64	HG50551	Thrust Bearing
65	HG51462	Thrust Bearing
66	HG72882	Kit, Motor Cylinder Block
67	HG70723	Kit, Cylinder Block
68	HG72291	Kit, Gerotor Seal
69	HG71436	Washer, 1.355 x 2.035 x .021 Flat
70	HG54974	Plug, 3/4 - 16
71	HG55072	Expansion Tank LH, Internal
	HG55071	Expansion Tank RH, Internal
72	HG73107	Seal Kit (Includes 25,26,23.35,56,28,
73	HG72320	

ZT-3400 HYDRAULIC AXLE ASSEMBLY - SPZ61

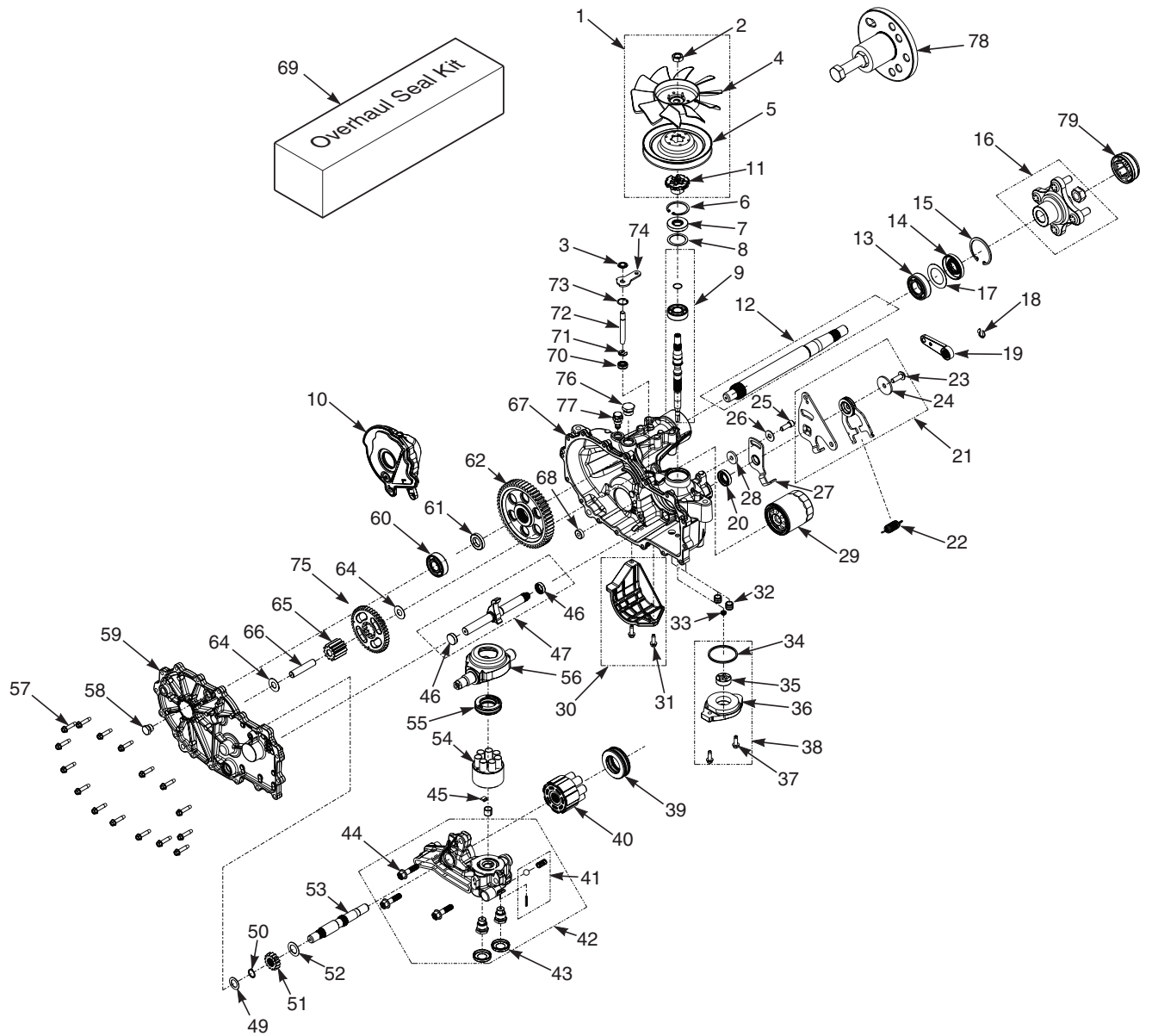

ZT-3400 HYDRAULIC AXLE ASSEMBLY - SPZ61

Ref. No.	Part No.	Description	Ref. No.	Part No.	Description
1	HG72658	Kit, Fan & Pulley	41	HG71436	Kit, Charge Relief
2	HG44133	Nut, Elastic Stop 1/2-20	42	HG71972	Kit, Center Section (Right Side)
3	HG51630	Ring, Retaining .375 External		HG71973	Kit, Center Section (Left Side)
4	HG52747	Fan, 7" (10 Blade)	43	HG52162	Seal, Plug 1.250 x .250
5	HG53435	Pulley"	44	HG52137	HFHCS, 3/8-16 X 1-1/2" Patch
6	HG50329	Ring, Retaining	45	HG51448	Plate, By-Pass
7	HG51161	Seal, Lip 17 x 40 x 7	46	HG51804	O-Ring, -111 x .103 x 424
8	HG50951	Washer, 1.23 x 1.56 x .04	47	HG73119	Kit Outboard RH Rot B / LH Rot A
9	HG71978	Kit, Input Shaft		HG73118	Kit Outboard RH Rot A/ LH Rot B
10	HG55071	Expansion Tank RH, Internal	48	HG52776	Pawl, Brake
	HG55072	Expansion Tank LH, Internal	49	HG44371	Washer, .63 x 1 x .05
11	HG2003014	Spring, Block	50	HG44145	Ring, Retaining .625
12	HG53528	Shaft, Axle	51	HG52341	Gear, 13T Steel
13	HG53656	Bearing, Ball 25.4 x 52 x 15	52	HG51069	Washer, .72 x 1.16 x .04
14	HG53699	Seal, Lip 1 x 2.049 x .375	53	HG52150	Shaft, Motor
15	HG50859	Ring, Retaining 2.06 Internal	54	HG71971	Assembly, Block 7 Piston
16	HG71405	Hub, 4-Bolt	55	HG53502	Bearing, Thrust
17	HG3514	Washer, 1.355 x 2.035 x .021 Flat	56	HG51048	Trunnion, Swashplate
18	HG53019	Clip, Retaining	57	HG53246	HFHCS, 1/4-20 x 1-1/8"
19	HG53973	Handle, Brake Actuating	58	HG54730	Plug, 9/16-18
20	HG51140	Seal, Lip 12 x 32 x 7	59	HG73255	Kit, Cover (Right Side)
21	HG71595	Kit, RTN Bi-Directional (Left Side)		HG73257	Kit, Cover (Left Side)
	HG71598	Kit, RTN Bi-Directional (Right Side)	60	HG72749	Bearing, Ball .75 x 40 x 12
22	HG52401	Spring, RTN	61	HG53336	Spacer, .750 x 1.320 x .257
23	HG51812	Bolt, Hex Head Cap Screw 5/16-24 x 1" Patch	62	HG54491	Gear, 54T
24	HG51950	Washer, .343 x 1.5 x .062	63	HG52110	Gear, 45T
25	HG51616	Bolt, Hex Head Cap Screw 5/16-24 x 1" Patch	64	HG50132	Washer, .5 X 1 X .03
26	HG44130	Washer, .34 x .88 x .06	65	HG52586	Gear, 11T Steel
27	HG51945	Arm, Neutral (Right Side)	66	HG51083	Jackshaft Pin
	HG51946	Arm, Neutral (Left Side)	67	HG73244	Kit, Housing Main (Right Side)
28	HG54315	Spacer, .320 x 1.005 x .179		HG73245	Kit, Housing Main (Left Side)
29	HG52114	Filter, Oil	68	HG51100	Magnet, Ring
30	HG73041	Guard, Filter (Right Side)	69	HG73239	Seal Kit
	HG71854	Guard, Filter (Left Side)	70	HG55232	Seal, Lip .375 x .75 x .25
31	HG53464	Screw, Hex Flange 1/4-20 x .625	71	HG51628	Ring, Retaining .375 External
32	HG52157	Tube, Connecting	72	HG52136	Rod, By-Pass
33	HG72291	Seal, Lip 8 x 12 x 3-VC	73	HG51627	Ring, Retaining .750 Internal
34	HG54501	O-Ring, -137 x .103 x 2.050	74	HG51629	Arm, By-Pass
35	HG50273	Gerotor Assembly (1.9 cc)	75	HG52110	Gear, 45T
36	HG53468	Cover, Charge Pump	76	HG54974	Plug, 3/4 - 16
37	HG53464	Screw, Hex Flange 1/4-20 x .625	77	HG55380	Fitting, 9/16 - 18, Breather
38	HG71977	Kit, Charge Pump	78	HG72320	Kit, Hub Puller
39	HG51462	Bearing, Thrust	79	HG53088	Axle Cap
40	HG72882	Assembly, Cylinder Block			

REPLACEMENT DECALS AND INFORMATION PLATES

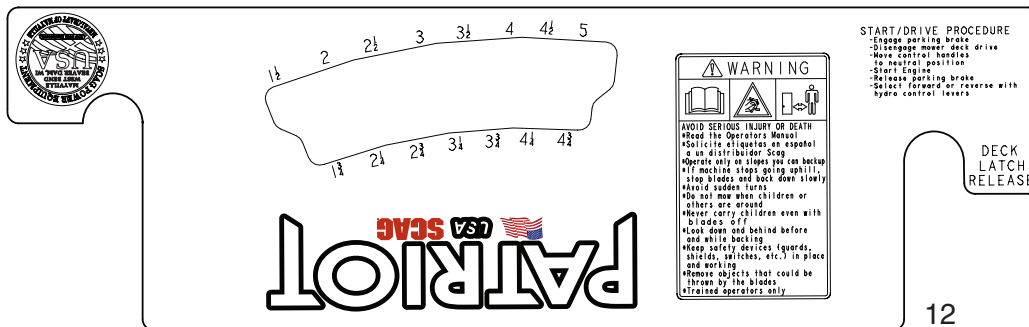
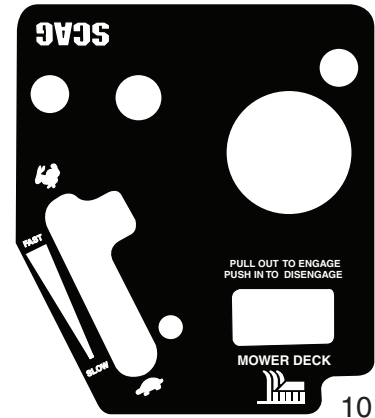
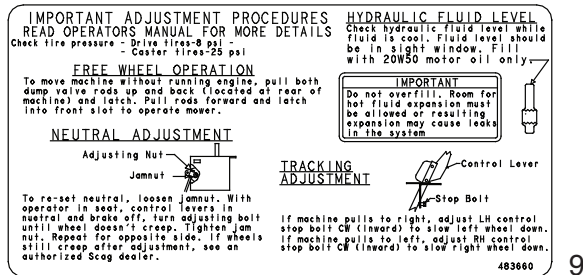
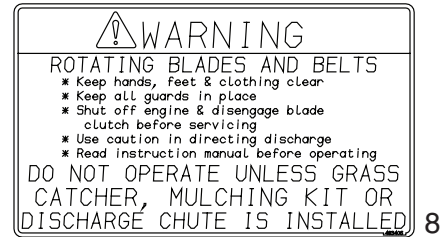
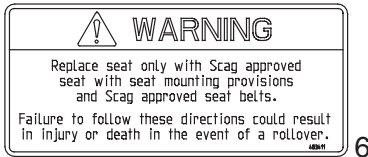

REPLACEMENT DECALS AND INFORMATION PLATES

Ref. No.	Part No.	Description
1	483402	Decal, Belt Cover
2	483405	Decal, Warning
3	486304	Decal, ROPS
4	483505	Decal, Spinning Blades
5	481568	Decal, Traction Control
6	483633	Decal, Seat Replacement
7	486795	Decal, 52H Commercial
	486796	Decal, 61H Commercial
8	483406	Decal, Knives
9	483660	Decal, Adjustment SPZ
10	486404	Decal, Instrument Panel
11	486831	Decal, Scag RH Fuel Tank
	486830	Decal, Scag LH Fuel Tank
12	486303	Decal, Cutting Height, (Scag Gold Logo)
13	484461	Decal, Brake
14	485708	Decal, SPZ Replacement Parts
15	485516	Decal, SPZ Belt Routing
*	483900	Decal, Warning Spark Arrestor (California only) - not shown
*	462155	Spanish Decal Kit - SPZ (not shown)
*	01411	DVD Video, Tips for Safe Operation of Your Scag Zero-Turn Mower (not shown)
16	486197	Decal, Scag - Fuel Tank
17	486300	Decal, Patriot, (Scag Gold Logo) - Fuel Tank
18	486301	Decal, Scag Patriot, (Scag Gold Logo) - Fuel Tank



13

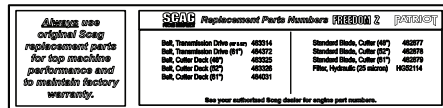

14

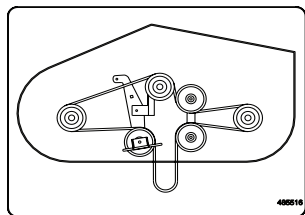

15



16



17



18

SPZ - ELECTRICAL SCHEMATIC

(shown with Key Off, PTO Off, Park Brake Applied, Control Handles in Neutral, Seat Switch Disengaged)

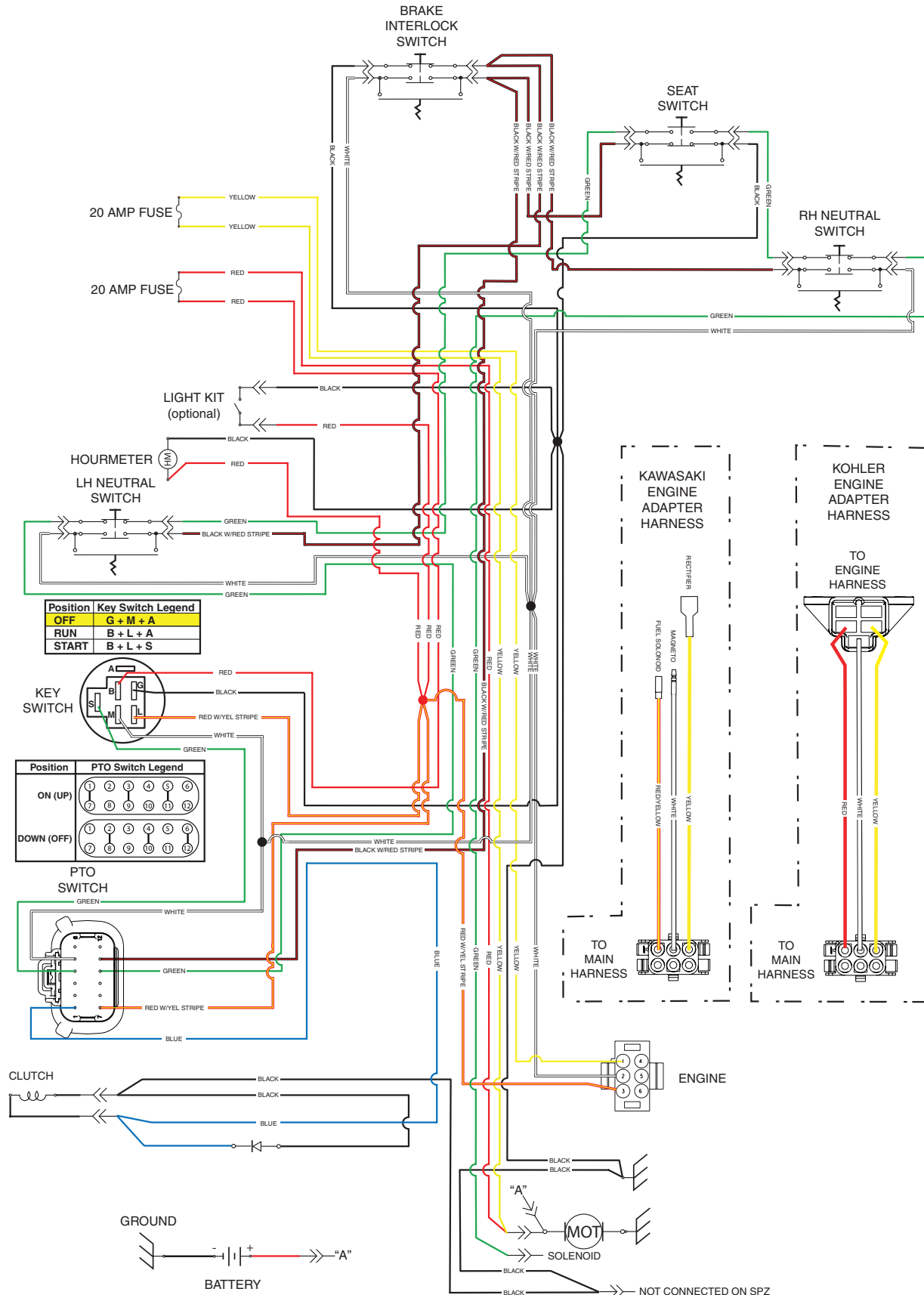

LIMITED WARRANTY - SPZ

Any part of the Scag commercial mower manufactured by Scag Power Equipment and found, in the reasonable judgment of Scag, to be defective in materials or workmanship, will be repaired or replaced by an Authorized Scag Service Dealer without charge for parts and labor during the periods specified below. This warranty is limited to the original purchaser provided the product was purchased from an Authorized Scag Power Equipment Dealer and is not transferable. Proof of purchase will be required by the dealer to substantiate any warranty claims. All warranty work must be performed by an Authorized Scag Service Dealer.

This warranty is limited to the following specified periods from the date of the original retail purchase for defects in materials or workmanship:

- Wear items including drive belts, blades, hydraulic hoses and tires are warranted for ninety (90) days.
- Batteries are covered for ninety (90) days.
- Frame and structural components including the oil reservoir are warranted for two (2) years (parts and labor) for commercial use or three (3) years / 500 hours (whichever comes first) (parts and labor) for non-commercial use.
- Cutter decks are warranted against cracking for a period of two (2) years. (parts and labor) for commercial use or three (3) years / 500 hours (whichever comes first) (First and second year of the warranty covers parts and labor. The third year covers parts or labor to repair) for non-commercial use. The repair or replacement of the cutter deck will be at the option of Scag Power Equipment. We reserve the right to request components for evaluation. This warranty does not cover any mower that has been subject to misuse, neglect, negligence, or accident, or that has been operated in any way contrary to the operating instructions as specified in the Operator's Manual.
- Engines and electric starters are covered by the engine manufacturer's warranty period.
- Major drive system components are warranted for two (2) years (parts and labor) for commercial use or three (3) year / 500 hour (whichever comes first) (Parts and labor) for non-commercial use by Scag Power Equipment. (commercial and non-commercial warranty excludes fittings, hoses, drive belts). The repair or replacement of the hydraulic axles will be at the option of Scag Power Equipment. This warranty does not cover any mower that has been subject to misuse, neglect, negligence, or accident, or that has been operated in any way contrary to the operating instructions as specified in the Operator's Manual.
- Electric clutches have a Limited Warranty for two (2) years (parts and labor) for commercial use or three (3) year / 500 hours (whichever comes first) (Parts and labor) for non-commercial use.
- Spindle assemblies have a Limited Warranty for two (2) year (parts and labor) for commercial use or three (3) years / 500 hours (whichever comes first) (First and second year of the warranty covers parts and labor. The third year covers parts only) for non-commercial use.
- Any Scag product used for rental purposes is covered by a 90 day warranty.

The Scag mower, including any defective part must be returned to an Authorized Scag Service Dealer within the warranty period. The expense of delivering the mower to the dealer for warranty work and the expense of returning it to the owner after repair will be paid for by the owner. Scag's responsibility is limited to making the required repairs and no claim of breach of warranty shall be cause for cancellation or rescission of the contract of sale of any Scag mower. "Non-Commercial" use is defined as a single property owner, where the single property is the residence of the owner of the mower. If the mower is cutting more than the owners single property, it is deemed commercial use and the "non-commercial" warranty does not apply. Scag Power Equipment reserves the right to deny and / or void the non-commercial warranty if it believes it to be in commercial use.

This warranty does not cover any mower that has been subject to misuse, neglect, negligence, or accident, or that has been operated in any way contrary to the operating instructions as specified in the Operator's Manual. The warranty does not apply to any damage to the mower that is the result of improper maintenance, or to any mower or parts that have not been assembled or installed as specified in the Operator's Manual and Assembly Manual. The warranty does not cover any mower that has been altered or modified, changing performance or durability. In addition, the warranty does not extend to repairs made necessary by normal wear, or by the use of parts or accessories which, in the reasonable judgment of Scag, are either incompatible with the Scag mower or adversely affect its operation, performance or durability.

Scag Power Equipment reserves the right to change or improve the design of any mower without assuming any obligation to modify any mower previously manufactured. All other implied warranties are limited in duration to the two (2) year warranty commercial use, three (3) years / 500 hour for non-commercial use or ninety (90) days for mowers used for rental purpose. Accordingly, any such implied warranties including merchantability, fitness for a particular purpose, or otherwise, are disclaimed in their entirety after the expiration of the appropriate two year, three year / 500 hour or ninety day warranty period. Scag's obligation under this warranty is strictly and exclusively limited to the repair or replacement of defective parts and Scag does not assume or authorize anyone to assume for them any other obligation. Some states do not allow limitations on how long an implied warranty lasts, so the above limitation may not apply to you.

Scag assumes no responsibility for incidental, consequential or other damages including, but not limited to, expense for gasoline, expense of delivering the mower to an Authorized Scag Service Dealer and expense of returning it to the owner, mechanic's travel time, telephone or telegram charges, rental of a like product during the time warranty repairs are being performed, travel, loss or damage to personal property, loss of revenue, loss of use of the mower, loss of time or inconvenience. Some states do not allow the exclusion or limitation of incidental or consequential damages, so the above limitation or exclusion may not apply to you. This warranty gives you specific legal rights, and you may also have other rights which vary from state to state.

