

SCAG[®]

POWER EQUIPMENT

OPERATOR'S MANUAL

TIGER CAT II



Models:

STCII-48V-22FX
STCII-48V-26MX
STCII-52V-25CV-EFI
STCII-52V-26FT-EFI
STCII-52V-27MX
STCII-52V-28BV-EFI
STCII-52V-29MX-EFI
STCII-61V-26FT-EFI
STCII-61V-27FX
STCII-61V-31MX-EFI
STCII-61V-32BV

Congratulations on owning a Scag mower! This manual contains the operating instructions and safety information for your Scag mower. Reading this manual can provide you with assistance in maintenance and adjustment procedures to keep your mower performing to maximum efficiency. The specific models that this book covers are listed on the inside cover. Before operating your machine, please read all the information enclosed.



WARNING

FAILURE TO FOLLOW SAFE OPERATING PRACTICES MAY RESULT IN SERIOUS INJURY OR DEATH.

- Read this manual completely as well as other manuals that came with your mower.
- DO NOT operate on steep slopes. To check a slope, attempt to back up it (with the cutter deck down). If the machine can back up the slope without the wheels slipping, reduce speed and use extreme caution.
- Under no circumstances should the machine be operated on slopes greater than 15 degrees. ALWAYS FOLLOW OSHA APPROVED OPERATION.
- Stay two cut widths away from slopes, drop offs, ditches, water and retaining walls.
- DO NOT mow on wet grass. Wet grass reduces traction and steering control.
- Keep all shields in place, especially the grass discharge chute.
- Before performing any maintenance or service, stop the machine and remove the spark plug wire and ignition key.
- If a mechanism becomes clogged, stop the engine before cleaning.
- Keep hands, feet and clothing away from power-driven parts.
- Keep others off the mower (only one person at a time)

REMEMBER - YOUR MOWER IS ONLY AS SAFE AS THE OPERATOR!

HAZARD CONTROL AND ACCIDENT PREVENTION ARE DEPENDENT UPON THE AWARENESS, CONCERN, PRUDENCE, AND PROPER TRAINING OF THE PERSONNEL INVOLVED IN THE OPERATION, TRANSPORT, MAINTENANCE, AND STORAGE OF THE EQUIPMENT.

This manual covers the operating instructions and illustrated parts list for:

STCII-48V-22FX	with a serial number of	S7400001 to S7499999
STCII-48V-26MX	with a serial number of	T3700001 to T3799999
STCII-52V-25CV-EFI	with a serial number of	S7500001 to A7599999
STCII-52V-26FT-EFI	with a serial number of	S7600001 to S7699999
STCII-52V-27MX	with a serial number of	T3800001 to T3899999
STCII-52V-28BV-EFI	with a serial number of	S7700001 to S7799999
STCII-52V-29MX-EFI	with a serial number of	T3900001 to T3999999
STCII-61V-26FT-EFI	with a serial number of	S7800001 to S7899999
STCII-61V-27FX	with a serial number of	S7900001 to S7999999
STCII-61V-31MX-EFI	with a serial number of	T4000001 to T4099999
STCII-61V-32BV	with a serial number of	S8000001 to S8099999

Always use the entire serial number listed on the serial number tag when referring to this product.

Table of Contents

NOTES.....	IV
SECTION 1 - GENERAL INFORMATION.....	1
1.1 INTRODUCTION.....	1
1.2 DIRECTION REFERENCE	1
1.3 SERVICING THE ENGINE AND DRIVE TRAIN COMPONENTS.....	1
1.4 SYMBOLS	2
SECTION 2 - SAFETY INFORMATION	3
2.1 INTRODUCTION.....	3
2.2 SIGNAL WORDS	3
2.3 BEFORE OPERATION CONSIDERATIONS.....	3
2.4 TESTING THE SAFETY INTERLOCK SYSTEM	4
2.5 OPERATION CONSIDERATIONS.....	5
2.6 ROLL-OVER PROTECTION SYSTEM.....	6
2.7 MAINTENANCE CONSIDERATIONS & STORAGE	9
2.8 USING A SPARK ARRESTOR.....	9
2.9 SPARK IGNITION SYSTEM	9
2.10 SAFETY AND INSTRUCTIONAL DECALS	10
SECTION 3 - SPECIFICATIONS	11
3.1 ENGINE	11
3.2 ELECTRICAL	11
3.3 MOWER.....	12
3.4 CUTTER DECK	12
3.5 HYDRAULIC SYSTEM	12
3.6 WEIGHTS AND DIMENSIONS.....	13
3.7 PRODUCTIVITY	13
SECTION 4 - OPERATING INSTRUCTIONS	14
4.1 TIGER EYE INSTRUMENT IDENTIFICATION	14
4.2 CONTROLS IDENTIFICATION	16
4.3 SAFETY INTERLOCK SYSTEM	17
4.4 TESTING THE SAFETY INTERLOCK SYSTEM	17
4.5 INITIAL RUN-IN PROCEDURES.....	18
4.6 STARTING THE ENGINE	18
4.7 GROUND TRAVEL AND STEERING	18
4.8 ENGAGING THE DECK DRIVE (CUTTER BLADES).....	19
4.9 HILLSIDE OPERATION.....	20
4.10 PARKING THE MOWER	20
4.11 AFTER OPERATION	20
4.12 REMOVING CLOGGED MATERIAL	20

4.13 MOVING MOWER WITH ENGINE STOPPED	21
4.14 RECOMMENDATIONS FOR MOWING	21
4.15 ADJUSTING CUTTING HEIGHT	22
4.16 TOWING (OPTIONAL HITCH ACCESSORY).....	22
SECTION 5 - TROUBLESHOOTING CUTTING CONDITIONS	23
SECTION 6 - ADJUSTMENTS	26
6.1 PARKING BRAKE ADJUSTMENT	26
6.2 TRAVEL ADJUSTMENTS	26
6.3 THROTTLE CONTROL AND CHOKE ADJUSTMENTS	28
6.4 BELT ADJUSTMENT	28
6.5 BELT ALIGNMENT.....	28
6.6 CUTTER DECK ADJUSTMENTS	28
6.7 CUSTOM-CUT BAFFLE ADJUSTMENT	30
6.8 ELECTRIC CLUTCH ADJUSTMENT.....	31
SECTION 7 - MAINTENANCE.....	33
7.1 MAINTENANCE CHART - RECOMMENDED SERVICE INTERVALS	33
7.2 LUBRICATION.....	34
7.3 HYDRAULIC SYSTEM	36
7.4 ENGINE OIL	37
7.5 ENGINE FUEL SYSTEM	37
7.6 ENGINE AIR CLEANER.....	38
7.7 BATTERY.....	39
7.8 DRIVE BELTS.....	39
7.9 CUTTER BLADES.....	40
7.10 TIRES.....	41
7.11 BODY, DECK, AND UPHOLSTERY	42

SECTION 8 - ILLUSTRATED PARTS LIST	43
8.1 SCAG APPROVED ATTACHMENTS AND ACCESSORIES.....	43
48V & 52V CUTTER DECKS	44
48V & 52V CUTTER DECKS	45
61V CUTTER DECK.....	46
61V CUTTER DECK.....	47
CUTTER DECK CONTROLS	48
CUTTER DECK CONTROLS	49
SHEET METAL COMPONENTS	50
SHEET METAL COMPONENTS	51
STCII FOLDABLE ROLL-OVER PROTECTION SYSTEM	52
STCII FOLDABLE ROLL-OVER PROTECTION SYSTEM	53
STCII SUSPENSION SEAT	54
STCII SUSPENSION SEAT	55
DRIVE SYSTEM COMPONENTS	56
DRIVE SYSTEM COMPONENTS	57
ENGINE & ATTACHING PARTS.....	58
ENGINE & ATTACHING PARTS.....	59
STEERING COMPONENTS.....	60
STEERING COMPONENTS.....	61
BRAKE COMPONENTS	62
BRAKE COMPONENTS	63
HYDRAULIC SYSTEM	64
HYDRAULIC SYSTEM	65
STCII FUEL SYSTEM.....	66
STCII FUEL SYSTEM.....	67
ELECTRICAL SYSTEM	68
ELECTRICAL SYSTEM	69
ELECTRICAL SYSTEM - KAWASAKI 26FT-EFI	70
ELECTRICAL SYSTEM - KAWASAKI 26FT-EFI	71
ELECTRICAL SYSTEM - KOHLER EFI / YAMAHA EFI.....	72
ELECTRICAL SYSTEM - KOHLER EFI / YAMAHA EFI.....	73
STCII HYDRAULIC PUMP ASSEMBLY	74
STCII HYDRAULIC PUMP ASSEMBLY	75
REPLACEMENT DECALS AND INFORMATION PLATES	76
REPLACEMENT DECALS AND INFORMATION PLATES	77
STCII - KAWASAKI FX / YAMAHA MX ELECTRICAL SCHEMATIC.....	78
STCII KAWASAKI FX ENGINE ADAPTER ELECTRICAL SCHEMATIC	79

NOTES

GENERAL INFORMATION

1.1 INTRODUCTION

Your mower was built to the highest standards in the industry. However, the prolonged life and maximum efficiency of your mower depends on you following the operating, maintenance and adjustment instructions in this manual.

If additional information or service is needed, contact your Scag Power Equipment Dealer.

We encourage you to contact your dealer for repairs. All Scag dealers are informed of the latest methods to service this equipment and provide prompt and efficient service in the field or at their service shop. They carry a full line of Scag service parts.

THE REPLACEMENT OF ANY PART ON THIS PRODUCT BY OTHER THAN THE MANUFACTURER'S AUTHORIZED REPLACEMENT PART MAY ADVERSELY AFFECT THE PERFORMANCE, DURABILITY OR SAFETY OF THIS PRODUCT.

USE OF OTHER THAN ORIGINAL SCAG REPLACEMENT PARTS WILL VOID THE WARRANTY.

When ordering parts, always give the model and serial number of your mower. The serial number plate is located where shown in Figure 1-1.

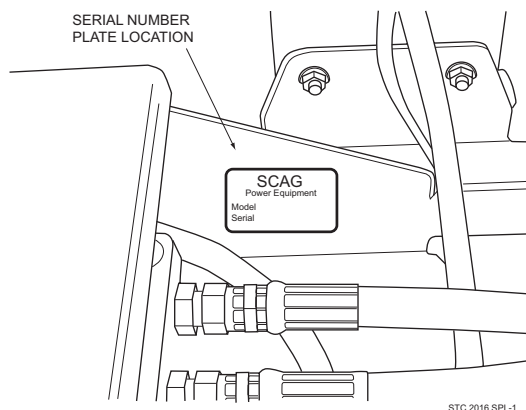

Figure 1-1. Mower Serial Number Plate Location

USE ONLY SCAG APPROVED ATTACHMENTS AND ACCESSORIES.

Attachments and accessories manufactured by companies other than Scag Power Equipment are not approved for use on this machine. See Section 8, Paragraph 8-1.



WARNING

For pictorial clarity, some illustrations and figures in this manual may show shields, guards or plates open or removed. Under no circumstances should your mower be operated without these devices in place.

All information is based upon product information available at the time of approval for printing. Scag Power Equipment reserves the right to make changes at any time without notice and without incurring any obligation.

















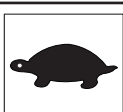

1.2 DIRECTION REFERENCE

The “Right” and “Left”, “Front” and “Rear” of the machine are referenced from the operator’s right and left when seated in the normal operating position and facing the forward travel direction.

1.3 SERVICING THE ENGINE AND DRIVE TRAIN COMPONENTS

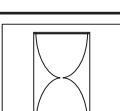
The details of servicing and repair of the engine, hydraulic pumps and gearboxes are not covered in this manual; only routine maintenance and general service instructions are provided. For service of these components during the limited warranty period, it is important to contact your Scag dealer or find a local authorized servicing agent of the component manufacturer. Any unauthorized work done on these components during the warranty period may void your warranty.

1.4 SYMBOLS

SYMBOL	DESCRIPTION	SYMBOL	DESCRIPTION
	Choke		Transmission
	Parking Brake		Spinning Blade
	On/Start		Spring Tension on Idler
	Off/Stop		Oil
	Falling Hazard		Thrown Object Hazard
	Fast		Slow
	Continuously Variable - Linear		Cutting Element - Basic Symbol
	Pinch Point		Cutting Element - Engage
	Hour meter/Elapsed Operating Hours		Cutting Element - Disengage
	Keep Bystanders Away		Read Operator's Manual

SAFETY INFORMATION

2.1 INTRODUCTION

Your mower is only as safe as the operator. Carelessness or operator error may result in serious bodily injury or death. Hazard control and accident prevention are dependent upon the awareness, concern, prudence, and proper training of the personnel involved in the operation, transport, maintenance and storage of the equipment. Make sure every operator is properly trained and thoroughly familiar with all of the controls before operating the mower. The owner/user can prevent and is responsible for accidents or injuries occurring to themselves, other people or property.

READ THIS OPERATOR'S MANUAL AND WATCH THE TIPS FOR SAFE OPERATION OF YOUR SCAG ZERO-TURN MOWER VIDEO BEFORE ATTEMPTING TO START YOUR MOWER.

A replacement manual is available from your authorized Scag Service Dealer or by contacting Scag Power Equipment, Service Department at P.O. Box 152, Mayville, WI 53050 or contact us via the Internet at www.scag.com. The manual for this machine can be downloaded by using the model and serial number or use the contact form to make your request. Please indicate the complete model and serial number of your Scag product when requesting replacement manuals.

2.2 SIGNAL WORDS



This symbol means **“Attention! Become Alert! Your Safety is Involved!”** The symbol is used with the following signal words to attract your attention to safety messages found on the decals on the machine and throughout this manual. The message that follows the symbol contains important information about safety. To avoid injury and possible death, carefully read the message! Be sure to fully understand the causes of possible injury or death.

SIGNAL WORD:

It is a distinctive word found on the safety decals on the machine and throughout this manual that alerts the viewer to the existence and relative degree of the hazard.

DANGER

The signal word “DANGER” denotes that an extremely hazardous situation exists on or near the machine that could result in high probability of death or irreparable injury if proper precautions are not taken.

WARNING

The signal word “WARNING” denotes that a hazard exists on or near the machine that can result in injury or death if proper precautions are not taken.

CAUTION

The signal word “CAUTION” is a reminder of safety practices on or near the machine that could result in personal injury if proper precautions are not taken.

Your safety and the safety of others depends significantly upon your knowledge and understanding of all correct operating practices and procedures of this machine.

2.3 BEFORE OPERATION CONSIDERATIONS

WARNING

Check all hydraulic connections for tightness. Inspect all hydraulic hoses and / or lines to insure they are in good condition before operating.

1. NEVER allow children to operate this riding mower. Do not allow adults to operate this machine without proper instructions.
2. Do not mow when children and/or others are present. Keep children out of the mowing area and in the watchful care of a responsible adult other than the operator. Be alert and turn machine off if a child enters the area.

3. DO NOT allow children to ride or play on the machine, it is not a toy.
4. Clear the area to be mowed of objects that could be picked up and thrown by the cutter blades.
5. DO NOT carry passengers.
6. DO NOT operate the machine under the influence of alcohol or drugs.
7. If the operator(s) or mechanic(s) cannot read English, it is the owner's responsibility to explain this material to them. A Spanish decal kit is available for this model. See your local Scag Dealer.
8. DO NOT wear loose fitting clothing. Loose clothing, jewelry or long hair could get tangled in moving parts. Do not operate the machine wearing shorts; always wear adequate protective clothing including long pants. Wearing safety glasses, safety shoes and a helmet is advisable and is required by some local ordinances and insurance regulations.

WARNING

Always wear hearing protection. Operating this machine over prolonged periods of time can cause loss of hearing.

9. Keep the machine and attachments in good operating condition. Keep all shields and safety devices in place. If a shield, safety device or decal is defective or damaged, repair or replace it before operating the machine.
10. Fuel is flammable; handle it with care. Fill the fuel tank outdoors. Never fill it indoors. Use a funnel or spout to prevent spillage. Clean up any spillage before starting the engine.
11. DO NOT add fuel to a running or hot engine. Allow the engine to cool for several minutes before adding fuel. Never fuel indoors or inside enclosed trailers.
12. Keep flammable objects (cigarettes, matches, etc.), open flames and sparks away from the fuel tank and fuel container. Use only approved containers.
13. See Section 7.5 ENGINE FUEL SYSTEM for fueling procedure.
14. Equipment must comply with the latest requirements per SAE J137 and/or ANSI/ASAE S279 when driven on public roads.

- NOTE -

If the mower is driven on public roads, it must comply with state and local ordinances as well as SAE J137 and/or ANSI/ASAE S279 requirements. Contact your local authorities for regulations and equipment requirements.

15. Do not operate without the side discharge chute installed and in the down position or with an optional grass catcher or mulch plate completely installed.
16. Check the blade mounting bolts at frequent intervals for proper tightness.
17. Make sure all hydraulic fluid connections are tight and all hydraulic hoses and lines are in good condition before starting the machine.

WARNING

This machine is equipped with an interlock system intended to protect the operator and others from injury. This is accomplished by preventing the engine from starting unless the deck drive is disengaged, the parking brake is on, the steering control levers are in the neutral position and the operator is in the seat. The system shuts off the engine if the operator leaves the seat with the deck drive engaged and/or the steering control levers are not in the neutral position and the parking brake is not engaged. Never operate equipment with the interlock system disconnected or malfunctioning.

18. Be sure the interlock switches are functioning correctly

2.4 TESTING THE SAFETY INTERLOCK SYSTEM

The safety interlock system should be tested each time before using the machine. If the safety interlock system does not operate as described below, contact your local Authorized Scag Power Equipment Dealer immediately to have the safety interlock system repaired.

1. Sit in the seat in the operating position, engage the parking brake, place the steering control levers in the neutral lock position, and engage the PTO switch to the ON (up) position. Try to start the engine; the engine should not start.

Section 2

2. Sit in the seat in the operating position, engage the parking brake, move either of the steering control handles out of the neutral lock position, move the PTO switch to the OFF (down) position. Try to start the engine; the engine should not start. Repeat for the other steering control lever.
3. Sit in the seat in the operating position, disengage the parking brake, place the steering control levers in the neutral lock position, move the PTO switch to the OFF (down) position. Try to start the engine; the engine should not start.
4. Sit in the seat in the operating position, engage the parking brake, place the steering control levers in the neutral lock position, move the PTO switch to the OFF (down) position, and start the engine. With the engine running, release the parking brake and rise slightly off of the seat. The engine should shut off.
5. Sit in the seat in the operating position, engage the parking brake, place the steering control levers in the neutral lock position, move the PTO switch to the OFF (down) position, and start the engine. With the engine running, engage the PTO switch to the ON (up) position, and rise slightly off of the seat. The engine should shut off.
6. Sit in the seat in the operating position, engage the parking brake, place the steering control levers in the neutral lock position, move the PTO switch to the OFF (down) position, and start the engine. With the engine running, move either steering control lever out of the neutral lock position. The engine should shut off. Repeat for the other steering control lever.
2. Reduce speed and exercise extreme caution on slopes and in sharp turns to prevent tipping or loss of control. Be especially cautious when changing directions on slopes.
3. Stay two cut widths away from slopes, drop offs, ditches, water and retaining walls.
4. To prevent tipping or loss of control, start and stop smoothly, avoid unnecessary turns and travel at reduced speed.
5. Immediately apply the parking brake if you lose steering control while operating. Inspect the machine and correct the problem before continuing to operate.
6. When using any attachment, never direct the discharge of material toward bystanders or allow anyone near the machine while in operation.
7. Before attempting to start the engine, with the operator in the seat, disengage power to the cutter deck, place the steering control levers in the neutral position and engage the parking brake.
8. If the mower discharge ever plugs, shut off the engine, remove the ignition key, and wait for all movement to stop before removing the obstruction.

2.5 OPERATION CONSIDERATIONS

1. Know the function of all controls and how to stop quickly.

WARNING

DO NOT operate on steep slopes. To check a slope, attempt to back up it (with the cutter deck down). If the machine can back up the slope without the wheels slipping, reduce speed and use extreme caution. Under no circumstances should the machine be operated on slopes greater than 15 degrees. See Figure 2-4, Page 8 to determine approximate slope of area to be mowed. ALWAYS FOLLOW OSHA APPROVED OPERATION.

WARNING

DO NOT use your hand to dislodge the clogged discharge chute. Use a stick or other device to remove clogged material after the engine has stopped running and the blades have stopped turning.

9. Be alert for holes, rocks, roots and other hidden hazards in the terrain. Keep away from any drop-offs. Beware of overhead obstructions (low limbs, etc.), underground obstacles (sprinklers, pipes, tree roots, etc.). Cautiously enter a new area. Be alert for hidden hazards.
10. Disengage power to cutter deck before backing up. Do not mow in reverse unless absolutely necessary and then only after observation of the entire area behind the mower. If you must mow in reverse, maintain a constant lookout to the rear of the machine and mow slowly.
11. DO NOT turn sharply. Use care when backing up.
12. Disengage power to cutter deck before crossing roads, walks or gravel drives.

13. Mow only in daylight or good artificial light.
14. NEVER raise the deck with the blades engaged.
15. Take all possible precautions when leaving the machine unattended, such as disengaging the mower, lowering the attachments, setting the parking brake, stopping the engine, and removing the key.
16. Disengage power to the attachments when transporting or when not in use.
17. The machine and attachments should be stopped and inspected for damage after striking a foreign object, and damage should be repaired before restarting and operating the machine.

CAUTION

Do not touch the engine or the muffler while the engine is running or immediately after stopping. These areas may be hot enough to cause a burn.

DANGER

DO NOT run the engine inside a building or a confined area without proper ventilation. Exhaust fumes are hazardous and contain carbon monoxide which can cause brain injury and death.

18. Keep hands and feet away from cutter blades and moving parts. Contact can injure.
19. Transport the mower using a heavy duty trailer or truck. Insure the trailer or truck has all of the necessary lighting and markings as required by laws, codes, and ordinances. Secure a trailer with a safety chain.
20. Be cautious when loading and unloading onto trailers or trucks. Use only a full width ramp. Ramp angle should be no more than 15 degrees. See Figure 2-4, Page 8 to determine approximate slope of the ramp. Back up the ramp and drive down forward.
21. When transporting the mower, make sure the park brake is engaged, the steering control levers are in the neutral position, the engine is off with the key removed, and the wheels have been blocked.

22. Tie the mower down securely using straps, chains, cable, or ropes. Both front and rear straps must be directed down and outward from machine.
23. Use care when approaching blind corners, shrubs, trees, or other objects that may obscure vision.
24. NEVER leave the machine running unattended.

2.6 ROLL-OVER PROTECTION SYSTEM

WARNING

Keep the roll bar in the raised and locked position and the seat belt securely fastened during operation. Failure to do so could cause serious injury or loss of life.

This mower has been designed for good traction and stability under normal mowing conditions. However, caution must be used when traveling on slopes, especially when the grass is wet. Do not mow on wet grass. Wet grass reduces traction and steering control.

Any or all parts of the Roll-Over Protection System MUST NOT be removed. Failure to adhere to this guideline could result in injury or death.

WARNING

There is no roll-over protection when the roll bar is in the down position.

Lower the roll bar only when absolutely necessary.

Raise the roll bar as soon as clearance permits.

DO NOT wear the seat belt when the roll bar is in the down position.

ALWAYS wear seat belt when roll bar is in the up position.

Operate the machine smoothly, no sudden turns, starts or stops.

Check the area carefully before mowing for proper overhead clearance (i.e. branches, doorways, etc.).

DO NOT contact any overhead object with the roll bar.

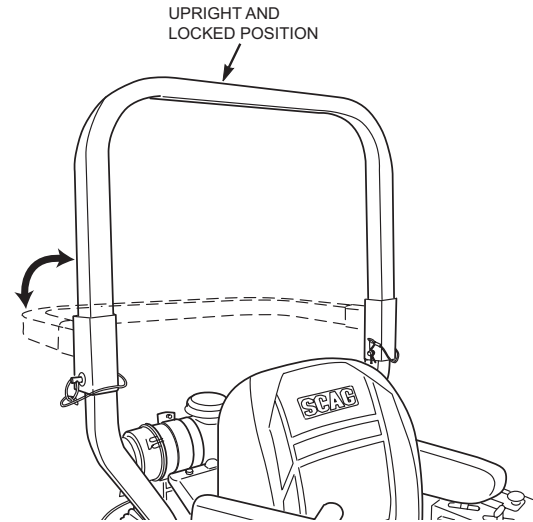

Figure 2-1. Foldable Roll-Over Protection System

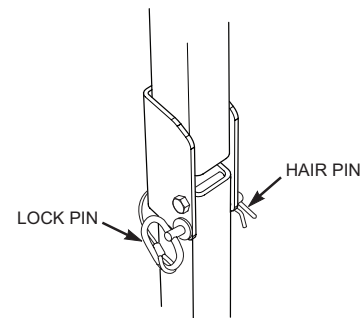

Figure 2-2. ROPS Hinge

Lower the roll bar only when absolutely necessary.

1. To lower the roll bar, remove the hairpin cotter pins and remove the two (2) lock pins. See Figure 2-2.
2. Lower the roll bar to the down position.
3. To raise the roll bar, lift the bar to the upright position.
4. Install the two (2) lock pins through the hole, secure with the two (2) hairpin cotter pins. See Figure 2-2.

The potential exposure of the seat belt to severe environmental conditions make it crucial to inspect the seat belt system regularly.

It is recommended that the seat belt be inspected on a daily basis for signs of damage. Any seat belt system that shows cuts, fraying, extreme or unusual wear, significant discoloration due to UV exposure, dirt or stiffness, abrasion to the seat belt webbing, or damage to the buckle, latch plate, hardware or any other obvious problem should be replaced immediately.

WARNING

Failure to properly inspect and maintain the seat belt can cause serious injury or loss of life.

1. Check the full length of the seat belt webbing for cuts, wear, fraying, dirt and stiffness. See Figure 2-3.
2. Check the seat belt webbing in areas exposed to ultra violet rays from the sun or extreme dust or dirt. If the original color of the webbing in these areas is extremely faded and/or is packed with dirt, the physical strength of this webbing may have deteriorated. If this condition exists, replace the seat belt system.
3. Check the buckle and latch for proper operation and determine if the latch plate is excessively worn, deformed, or if the buckle is damaged or cracked. See Figure 2-3.

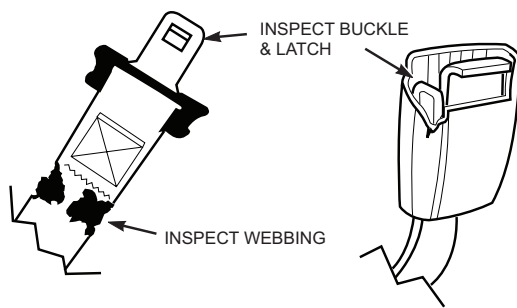

Figure 2-3. Seat Belt Inspection

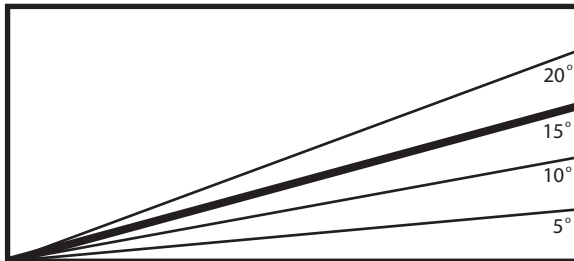

Figure 2-4. Slope Angle Graph

WARNING

Reduce speed when turning, operating on slopes, slick or wet surfaces. Allow extra distance to stop.

Stay off of slopes too steep for safe operation. To check a slope, attempt to back up it (with the cutter deck down). If the machine can not back up the slope without the wheels slipping, do not operate the machine on this slope. Under no circumstances should the machine be operated on slopes greater than 15 degrees. See Figure 2-4 to determine approximate slope.

DO NOT mow near drop-offs, ditches or embankments. The machine could suddenly roll over if a wheel goes over the edge or if the edge caves in.

Operate the machine smoothly, no sudden turns, starts or stops on a slope.

NEVER tow on slopes. The weight of the towed equipment may cause loss of traction and loss of control.

DO NOT permit untrained personnel to operate the machine.

Be cautious when loading and unloading onto trailers or trucks.

Use only a full width ramp.

Ramp angle should be no more than 15 Degrees. See Figure 2-4 to help determine approximate slope.

Back up the ramp and drive down forward.

Section 2

2.7 MAINTENANCE CONSIDERATIONS & STORAGE

1. Never make adjustments to the machine with the engine running unless specifically instructed to do so. If the engine is running, keep hands, feet, and clothing away from moving parts.
2. Disengage drives, lower implement, set parking brake, stop engine and remove key or disconnect spark plug wire to prevent accidental starting of the engine when servicing or adjusting the machine. Wait for all movement to stop before adjusting, cleaning or repairing.
3. Disconnect battery or remove spark plug wire before making any repairs. Disconnect the negative terminal first and the positive last. Reconnect the positive first and the negative last.
4. Keep all nuts, bolts and screws tight, to ensure the machine is in safe working condition. Check blade mounting bolts frequently to be sure they are tight.
5. Do not change the engine governor settings or overspeed the engine. See the engine operator's manual for information on engine settings.
6. To reduce fire hazard, keep the cutting units, drives, muffler and engine free of grass, leaves, excessive grease, oil and dirt.
7. Park the machine on level ground and engage the parking brake.
8. NEVER allow untrained personnel to service the machine.
9. Use care when checking blades. Use a Blade Buddy, wrap the blade(s) or wear gloves and USE CAUTION when servicing blades. Only replace blades. NEVER straighten or weld blades.
10. Keep all parts in good working condition. Replace all worn or damaged decals.
11. Use jack stands to support components when required.
12. Carefully release pressure from components with stored energy.

WARNING

Hydraulic fluid is under high pressure and can penetrate skin causing injury. If hydraulic fluid is injected into the skin, it must be surgically removed within a few hours by a doctor or gangrene may result.

Keep body and hands away from pinholes or nozzles that eject hydraulic fluid under high pressure. Use paper or cardboard and not hands to search for leaks.

Safely relieve all pressure from the hydraulic system by placing the control levers in the neutral lock position and shutting off the engine before performing any work on the hydraulic system.

If you need service on your hydraulic system, please see your authorized Scag dealer.

13. Let the engine cool before storing.
14. DO NOT store the machine near an open flame.
15. Shut off fuel while storing or transporting.
16. DO NOT store fuel near flames or drain indoors.
17. Charge batteries in an open, well ventilated area, away from spark and flames. Unplug charger before connecting or disconnecting from battery. Wear protective clothing and use insulated tools.

2.8 USING A SPARK ARRESTOR

The engine in this machine is not equipped with a spark arrestor muffler. It is in violation of California Public Resource Code Section 4442 to use or operate this engine on or near any forest covered, brush covered or grass covered land unless the exhaust system is equipped with a spark arrestor meeting any applicable local or state laws. Other states or federal areas may have similar laws. Check with your state or local authorities for regulations pertaining to these requirements.

2.9 SPARK IGNITION SYSTEM

This spark ignition system complies with Canadian ICES-002.

2.10 SAFETY AND INSTRUCTIONAL DECALS



483407



483402

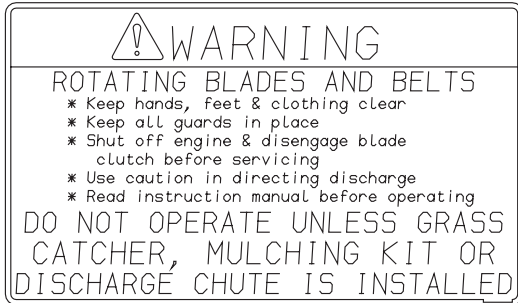

483406

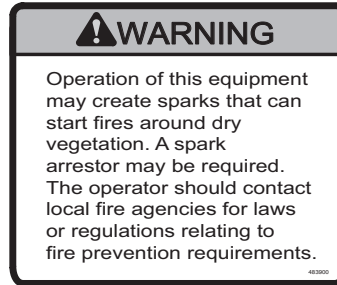
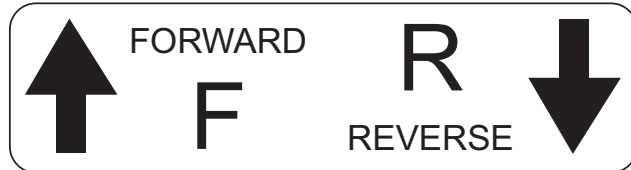

483900

(supplied with California models only)

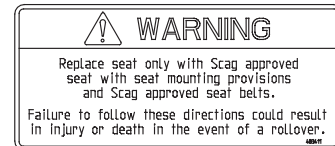

483633

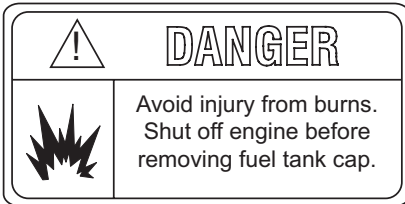

483397

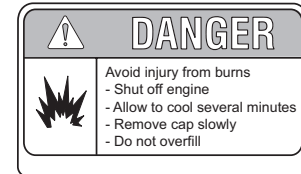

Molded in Fuel Tank

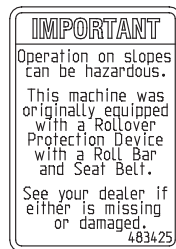

483425

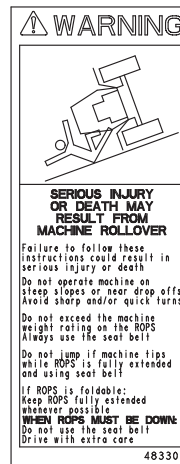

483300

SPECIFICATIONS

3.1 ENGINE

General Type	Heavy Duty Industrial/Commercial Gasoline
Brand	Kohler, Kawasaki, Briggs & Stratton Vanguard
Engine Model:	
Scag Model STCII-48V-22FX	Kawasaki FX691V
Scag Model STCII-48V-26MX	Yamaha MX800V
Scag Model STCII-52V-25CV-EFI	Kohler ECV740
Scag Model STCII-52V-26FT-EFI	Kawasaki FT730V
Scag Model STCII-52V-27MX	Yamaha MX825V
Scag Model STCII-52V-28BV-EFI	Briggs & Stratton Vanguard
Scag Model STCII-52V-29MX-EFI	Yamaha MX775V-EFI
Scag Model STCII-61V-26FT-EFI	Kawasaki FT730V
Scag Model STCII-61V-27FX	Kawasaki FX850V
Scag Model STCII-61V-31MX-EFI	Yamaha MX800V-EFI
Scag Model STCII-61V-32BV	Briggs & Stratton Vanguard
Displacement:	
Kawasaki 22FX, 26FT (FX691V, FT730V)	726cc
Kohler ECV740	747cc
Briggs & Stratton 28BV-EFI	810cc
Yamaha MX Series	824cc
Kawasaki 27FX	852cc
Briggs and Stratton 32BV	896cc
Type	4 Cycle Gasoline, Twin Cylinder, Vertical Shaft
Cylinders	2 with Cast Iron Sleeves
Governor	Mechanical Type with Variable Speed Control Set At 3600 RPM
Kawasaki FT730V	Integrated Electronic - 3600 RPM
Idle Speed:	
Kohler	1900 RPM
Briggs and Stratton	1750 RPM
Yamaha	1750 RPM
Kawasaki	1550 RPM
Fuel Pump	Integral Fuel Pump with In-Line Fuel Filter
Fuel	Non-Leaded Gasoline with a Minimum Octane Rating of 87
Oil Pump	Positive Displacement Gerotor™
Starter:	
Kawasaki FX / FT, Kohler, Yamaha, & Briggs and Stratton	Electric Starting with Solenoid Shift Starter
Belts	Kevlar cord. Self-adjusting, Self-tightening

3.2 ELECTRICAL

Battery	12 Volt
Charging System	Alternator
Charging Output:	
Kohler	12 Volt, 15 Amp
Kawasaki	12 Volt, 13 Amp
Briggs & Stratton	12 Volt, 20 Amp
Yamaha	12 Volt, 25 Amp
System Polarity	Negative Ground
Starter	12 Volt Electric Ring Gear Type, Key and Solenoid Operated
Interlock Switches	Seat, Neutral Control, Mower Engagement (PTO), Parking Brake
Instrument Panel	Tiger Eye Advanced Monitoring System, Key Switch, Throttle Lever, Manual Choke (Non-EFI), PTO Switch, Fuses and Check Engine Indicator (EFI)
Fuses	Two (2) 20 Amp

3.3 MOWER

Drive System	Hydraulic Drive with Two Variable Displacement Pumps and Two Cast-iron High-Torque Motors
Hydrostatic Pumps	Two Hydro-Gear™ 12 cc/rev. Pumps with Fans and Dump Valves for movement without running the engine
Drive Wheel Motors	Two Parker Cast-Iron High-Torque Motors
Steering/Travel Control	Twin Lever Fingertip Steering Control with Individual Control to Each Wheel with Gas Spring Dampers
Parking Brake	Foot Pedal Actuated Linkage to Brakes on Both Drive Wheel Axles
Wheels:	
(2) Front Caster (48"-52" Deck)	13 X 5-6 Four-Ply w/Tapered Roller Bearing Pivots
(2) Front Caster Wheel (61" Deck)	13 x 6.5-6 Four-Ply w/Tapered Roller Bearing Pivots
(2) Drive - (48"-52" Deck)	24 X 9.50 X 12 Four-Ply Pneumatic Tubeless, Radius Edge
(2) Drive - (61" Deck).....	24 x 12 x 12 Four-Ply Pneumatic Tubeless, Radius Edge
Tire Pressure:	
Front Caster.....	Flat Free
Drive	12 PSI
Fuel Tanks	Dual (5.3 Gal. RH, 5.7 Gal. LH) Seamless Roto-Low Perm. Tanks with Large Opening and Fuel Cap Seat
	Padded, Thick Cushion with Extra Spring Support
Travel Speed:	
Forward	0 up to 12 MPH
Reverse	0 up to 5 MPH
-NOTE- The machine will travel up to 12 mph for transport purposes. For best cutting performance the forward travel speed should be adjusted depending upon the cutting conditions.	

3.4 CUTTER DECK

Type	Floating, Adjustable, Anti-Scalping, Hybrid Design Combines Out-Front and Belly-Mount Designs
Construction	Tri-plate deck construction
	Top of deck consists of three steel plates totaling nearly 1/2" of steel, 7-gauge (3/16") deck skirt.
True Cutting Width:	
48V	48" (122.0 cm)
52V	52" (132.0 cm)
61V	61" (154.94 cm)
Cutting Height Adjustment.....	Foot-Operated Lever Adjustment from Operator's Seat, 1.00" to 5.5" in 1/4" increments
Cutter Blades.....	0.197 in. Thick, Milled Edge, Wear Resistant
Blade Engagement.....	Electric Blade Engagement Clutch with Control Panel Switch Connected to the Cutter Deck through a Belt.
Discharge Opening.....	Extra Wide Discharge Opening with Spring-Loaded Discharge Chute and Turbo Baffle
Discharge Chute.....	Black, Polypropylene (Plastic), Flexible
Spindles.....	Heavy-Duty 1-1/8" Top Dimension Spindle Shaft, Cast Housing, Taper Roller Bearing, Low Maintenance with Top Access Grease Fitting and Grease Overfill Relief Poppet
Spindle Pulleys	Split Steel with Easily Removed Taper Hubs
Cutter Deck Belts.....	B-section and Cogged Type with Kevlar Cord. Self-Adjusting, Self-Tightening
Electric Clutch Type	Ogura Heavy Duty PTO Clutch Brake

3.5 HYDRAULIC SYSTEM

Hydraulic Oil Filter	10 Micron Spin-on Element Type
Hydraulic Reservoir	Nylon; 4 Quart Capacity

Section 3

3.6 WEIGHTS AND DIMENSIONS

	48V	52V	61V
Length.....	81"	81.5"	85.5"
Tracking Width	47"	48.75"	51.5"
Overall Width w/chute down	60.5"	64.5"	73.5"
Overall Width w/chute up.....	49.75"	53.75"	62.75"
Overall Height w/ROPS (up on Folding Models)	67.25"	67.25"	67.25"
Overall Height w/ROPS down (Folding Models).....	46.75"	46.75"	46.75"
Operating Weight w/ROPS	1171#	1175-1180#	1257-1277#

3.7 PRODUCTIVITY

	48V	52V	61V
Cutting Width	48"	52"	61"
Acres Per Day.....	18.6	20.2	23.7

The preceding chart will aid you in determining how many acres your Scag mower will cut per day. The chart is an estimate based on 8 hours per day cutting time at 6 MPH with a 20% allowance for overlap and turns.

OPERATING INSTRUCTIONS

CAUTION

Do not attempt to operate this mower unless you have read this manual. Learn the location and purpose of all controls and instruments before you operate this mower.

Before operating the mower, familiarize yourself with all mower and engine controls. Knowing the location, function and operation of these controls is important for safe and efficient operation of the mower.

This machine is equipped with the Tiger Eye Advanced Monitoring System. With the key in the on position, before starting the engine, the lights for the Seat Indicator, PTO Indicator, Neutral Indicator and Park Brake Indicator should be illuminated. This indicates there is an operator in the seat, the PTO is off, steering levers are in neutral, and the parking brake is applied. When all the lights are illuminated, the key can be turned to the start position and the mower can be started. See Section 4.3 Safety Interlock System. If any of these indicator lights are not illuminated, the engine will be prevented from starting. If additional information or service is needed, contact your Scag Power Equipment Dealer.

4.1 TIGER EYE INSTRUMENT IDENTIFICATION

1. **Service Air Filter Indicator (Figure 4-1). Optional Accessory.** Indicates the condition of the engine air filter. Icon will display when it is time to change the air filter.
2. **Glow Plug Indicator (Figure 4-1). Used on Diesel Powered Units Only.** Indicator turns on when the key switch is turned to the PREHEAT position. Glow plugs must be preheated for 5 to 10 seconds before starting the engine.
3. **Oil Pressure Indicator (Figure 4-1). Used on Diesel Powered Units Only.** Indicates engine oil pressure. Reference the engine operator's manual for further information.
4. **Service Engine Indicator (Figure 4-1).** Indicates the maintenance reminder for the engine oil change. Has preset maintenance reminder and will start flashing scheduled maintenance 2 hours before preset time and continue flashing until 2 hours after. Automatically resets.
5. **Voltmeter Indicator (Figure 4-1).** Indicates the condition of the charging system. When the engine is running, in normal operating conditions, the bar graph should be in the 12 to 14 volt range.
6. **Seat Indicator (Figure 4-1).** Light will illuminate when the operator is in the seat engaging the seat switch.
7. **PTO Indicator (Figure 4-1).** Light will illuminate when the PTO (mower deck) switch is in the OFF position.
8. **Hourmeter Indicator (Figure 4-1).** Indicates the number of hours the engine has been operated. It only operates when the engine is running. Will start flashing with the Service Engine Indicator at scheduled maintenance 2 hours before preset time and continue flashing until 2 hours after. Automatically resets.
9. **Neutral Indicator (Figure 4-1).** Light will illuminate when the steering control levers are in the neutral lock position.
10. **Park Brake Indicator (Figure 4-1).** Light will illuminate when the park brake is in the engaged (ON) position.
11. **Water Temperature Indicator (Figure 4-1). Used on Liquid Cooled Models Only.** Indicates the operating temperature of the engine. If the engine temperature exceeds the maximum preset value, the indicator will flash and the Park Brake, PTO, Seat and Neutral indicator lights will flash in an alternating pattern.
12. **Fuse Holders (Figure 4-2).** Two 20-amp fuses protect the mower's electrical system. To replace fuses, pull fuse out of the socket and install a new fuse.

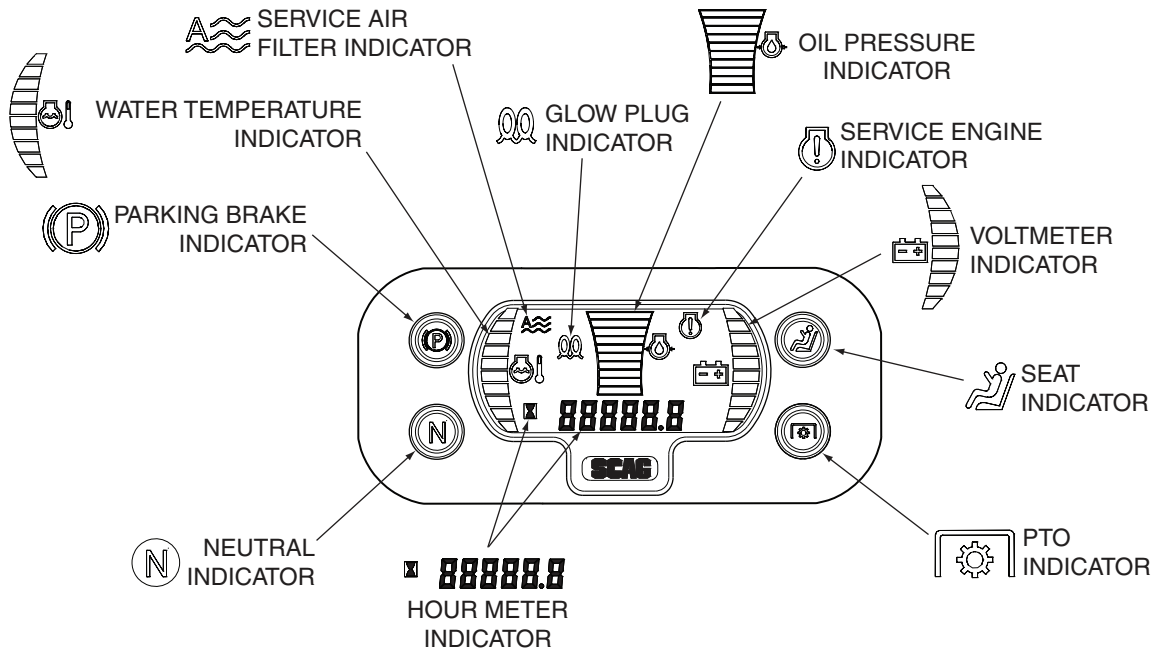

Figure 4-1. Tiger Eye Advanced Monitoring System

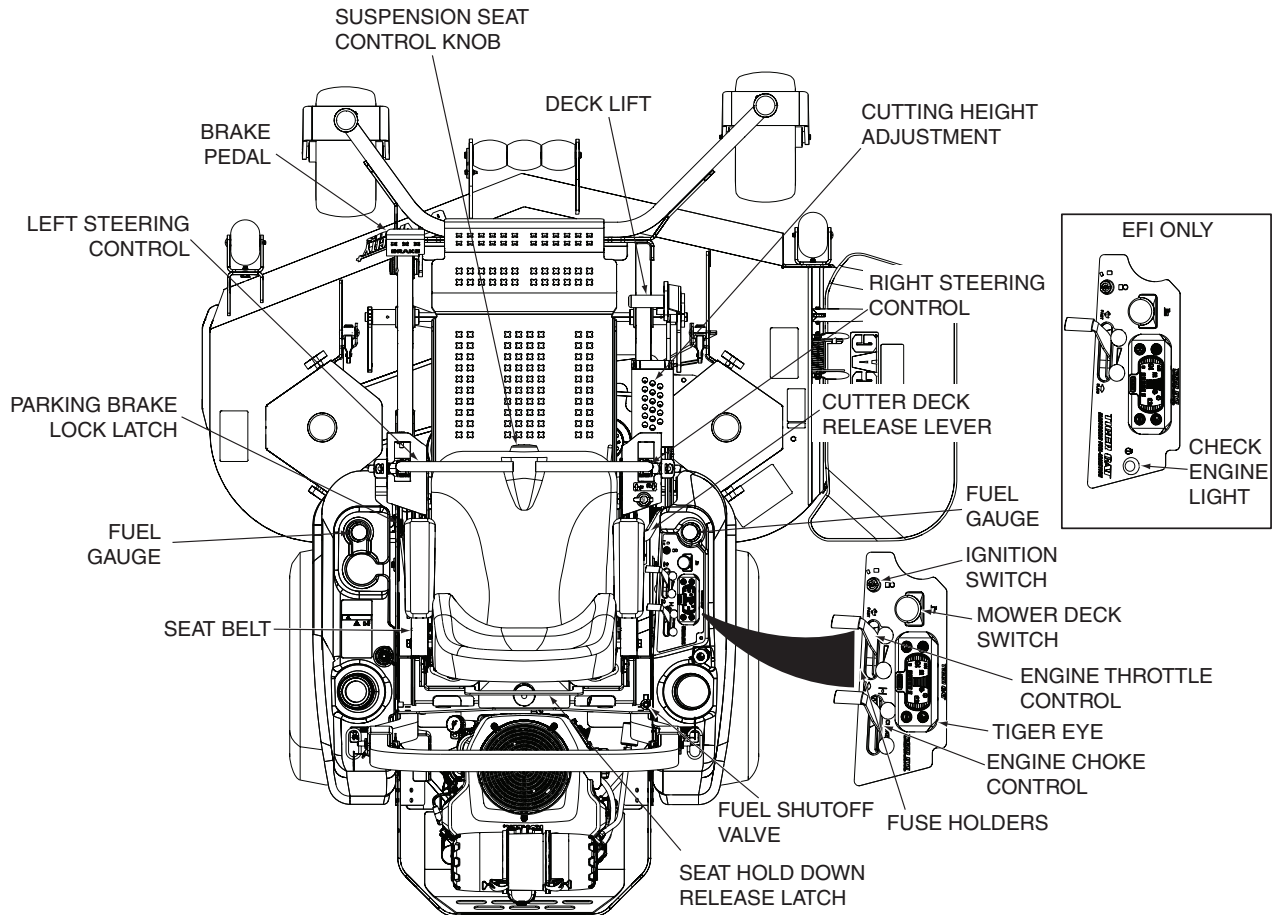

Figure 4-2. Controls and Instruments

4.2 CONTROLS IDENTIFICATION

1. **Ignition Switch (Figure 4-2).** The ignition switch is used to start the engine and has three positions; OFF, ON, and START.
2. **Mower Deck Switch (Figure 4-2).** Used to engage and disengage the mower drive system. Pulling up on the switch will engage the deck drive. Pushing down on the switch will disengage the deck drive.
3. **Engine Choke Control (Figure 4-2).** Used to start a cold engine.
4. **Engine Throttle Control (Figure 4-2).** Used to control the engine speed. Pushing the lever forward increases engine speed. Pulling the lever back decreases engine speed. Full back position is the IDLE position. Full forward is the cutting position.
5. **Left Steering Control (Figure 4-2).** Used to control the mower's left wheel when traveling forward or reverse.
6. **Right Steering Control (Figure 4-2).** Used to control the mower's right wheel when traveling forward or reverse.
7. **Brake Pedal (Figure 4-1).** Depressing the brake pedal applies the brake.
8. **Parking Brake Lock Latch (Figure 4-2).** Used to lock the parking brake in the engaged position. Fully depress the brake pedal and pull the parking brake lock latch back to lock the parking brake in the engaged position. See Figure 4-3. Fully depress the brake pedal forward to disengage the parking brake lock latch, then release the brake pedal to disengage the brake. See Figure 4-4.

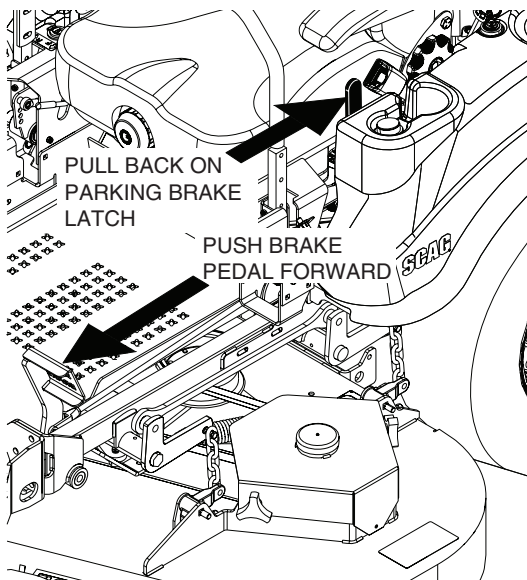

Figure 4-3. Engaging Parking Brake

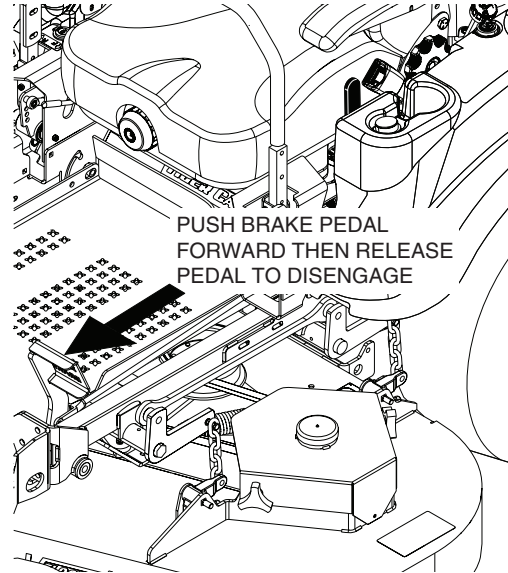

Figure 4-4. Releasing the Parking Brake

9. **Fuel Tank Gauge (Figure 4-2).** Indicates the amount of fuel in the fuel tank.
10. **Dump Valve Control Levers (Figure 4-5).** Located on the hydraulic pumps, used to “free-wheel” the mower. Rotating clockwise until they stop allows the unit to move under hydraulic power. The levers must be in this position and torqued to 10 lb-ft during operation of the mower. Rotating counter-clockwise allows the mower to be moved by hand (free-wheeling). See Figure 4-5.

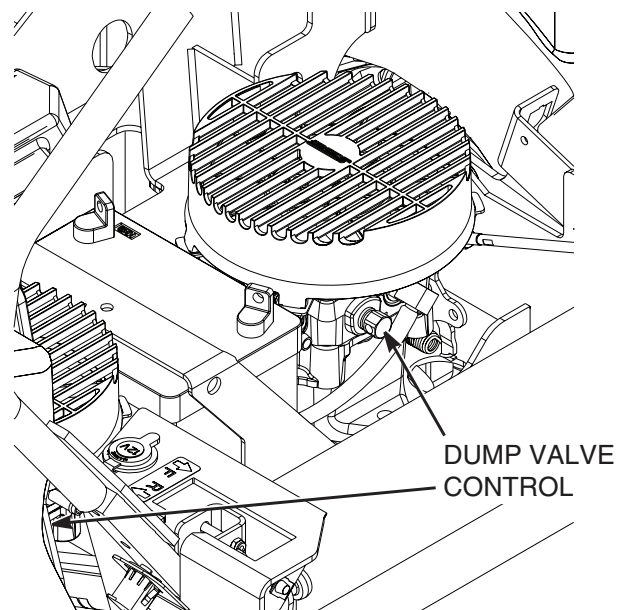

Figure 4-5. Dump Valve Control

11. **Deck Lift Foot Lever (Figure 4-2).** Used to raise and lower the cutter deck. Push full forward to lock in the transport position.

Section 4

12. **Cutting Height Adjustment (Figure 4-2).** Used to set the cutter deck at the desired cutting height.
13. **Deck Release Lever (Figure 4-2).** Used to lock the cutter deck in the transport position. Push the foot pedal forward and pull back on the release lever to release the cutter deck for normal mowing.
14. **Seat Suspension Control Knob (Figure 4-2).** Used to select the optimum suspension rate based on the operator.
15. **Seat Belt (Figure 4-2).** Used to secure the operator. Seat belt must be worn at all times when the ROPS is in the upright and locked position.
16. **Seat Hold Down Release Latch (Figure 4-2).** Located behind the seat. Used to secure the seat in the operator's position. Release the latch to gain access under the seat.
17. **Fuel Switching Valve (Figure 4-2).** Located on the right side of the machine. Used to shut off fuel supply to the engine and change fuel supply between the fuel tanks. Rotate the valve counter clockwise to supply fuel from the tank on the left side only. Rotate the valve clockwise to supply fuel from the tank on the right side only.

4.3 SAFETY INTERLOCK SYSTEM

The mower is equipped with a safety interlock system that prevents the engine from starting unless the deck drive is disengaged, the parking brake is engaged, the steering control levers are in the neutral position and the operator is in the seat. The interlock system shuts off the engine if the operator leaves the seat with the steering control levers not in the neutral position and/or the cutter blades engaged and the parking brake not engaged.

WARNING

Never operate the mower with the interlock system disconnected or malfunctioning. Do not disengage or bypass any switch; injury to yourself and others or property damage could result.

4.4 TESTING THE SAFETY INTERLOCK SYSTEM

The safety interlock system should be tested each time before using the machine. If the safety interlock system does not operate as described below, contact your local Authorized Scag Power Equipment Dealer immediately to have the safety interlock system repaired.

1. Sit in the seat in the operating position, engage the parking brake, place the steering control levers in the neutral lock position, and engage the PTO switch to the ON (up) position. Try to start the engine; the engine should not start.
2. Sit in the seat in the operating position, engage the parking brake, move either of the steering control handles out of the neutral lock position, move the PTO switch to the OFF (down) position. Try to start the engine; the engine should not start. Repeat for the other steering control lever.
3. Sit in the seat in the operating position, disengage the parking brake, place the steering control levers in the neutral lock position, move the PTO switch to the OFF (down) position. Try to start the engine; the engine should not start.
4. Sit in the seat in the operating position, engage the parking brake, place the steering control levers in the neutral lock position, move the PTO switch to the OFF (down) position, and start the engine. With the engine running, release the parking brake and rise slightly off of the seat. The engine should shut off.
5. Sit in the seat in the operating position, engage the parking brake, place the steering control levers in the neutral lock position, move the PTO switch to the OFF (down) position, and start the engine. With the engine running, engage the PTO switch to the ON (up) position, and rise slightly off of the seat. The engine should shut off.
6. Sit in the seat in the operating position, engage the parking brake, place the steering control levers in the neutral lock position, move the PTO switch to the OFF (down) position, and start the engine. With the engine running, move either steering control lever out of the neutral lock position. The engine should shut off. Repeat for the other steering control lever.

4.5 INITIAL RUN-IN PROCEDURES

FIRST DAY OF USE OR APPROXIMATELY 20 HOURS

1. Check all belts for proper alignment and wear at 2, 4 and 8 hours.
2. Change the engine oil and oil filter after the first 20 hours of operation. (See Section 7.4.)
3. Check hydraulic oil level in reservoir. (See Section 7.3.)
4. Check for loose hardware. Tighten as needed.
5. Check interlock system for proper operation. (See Section 4.4.)
6. Check tire pressure. Adjust pressure if necessary. (See Section 7.10.)

4.6 STARTING THE ENGINE

CAUTION

DO NOT USE STARTING FLUIDS. Use of starting fluids in the air intake system may be potentially explosive or cause a “runaway” engine condition that could result in engine damage and/or personal injury.

1. Be sure the fuel shutoff valve, located behind the operator's seat, is completely open. (See Section 7.5.)
2. Secure the ROPS in the upright and locked position.
3. Sit in the operator's seat, fasten seat belt and place the steering control levers in the neutral position.
4. Engage the parking brake.
5. Place the PTO switch in the disengaged position.
6. If the engine is cold, choke the engine as needed.
7. Move the engine throttle control to about half engine speed.
8. Turn the ignition key to the START position and release the key as soon as the engine starts. Do not hold the key in the START position for more than 15 seconds at a time. Allow at least 60 seconds between each cranking attempt to prevent overheating of the starter motor. Prolonged cranking can damage the starter motor and shorten battery life.

9. Allow engine to warm before operating the mower.

4.7 GROUND TRAVEL AND STEERING

- IMPORTANT -

If you are not familiar with the operation of a machine with lever steering and/or hydrostatic transmissions, the steering and ground speed operations should be learned and practiced in an open area, away from buildings, fences, or obstructions.

Learn the operation on flat ground before operating on slopes.

Start practicing with a slow engine speed and slow forward travel.

Learn to feather the steering controls to obtain a smooth operating action.

Practice operating the mower until you are comfortable with the controls before proceeding to mow.

FORWARD TRAVEL

To travel forward with the mower, disengage the parking brake, pull levers inward out of the neutral lock position and slowly push the steering control levers forward an equal distance. The further the steering control levers are pushed forward the greater the forward speed will be. To increase the speed, push the steering control levers further forward and to decrease the speed, pull the steering control levers back.

To stop the forward travel, pull the steering control levers back to the neutral position.

To steer the mower left while traveling forward, pull the left steering lever back. The further the lever is pulled back, the quicker the mower will turn left.

To steer the mower right while traveling forward, pull the right steering control lever back. The further the lever is pulled back, the quicker the mower will turn right.

- NOTE -

Smooth operation of the steering levers will produce smooth mower operation. While learning the operation of the steering controls, keep the travel speed low.

Section 4

- IMPORTANT -

Do not travel forward over a curb. The mower will hang up on the curb. Raise the deck and travel backwards over the curb at a 45 degree angle. (See Figure 4-2 items 11-13 for cutter deck raising description.)

REVERSE TRAVEL

CAUTION

Disengage power to the mower before backing up. Do not mow in reverse unless absolutely necessary and then only after observation of the entire area behind the mower.

CAUTION

Before backing up, observe the rear for persons and obstructions. Clear the area before backing up. Possible injury or property damage could occur.

To travel in reverse, pull levers inward out of the neutral lock position and pull both handles back. Keep the travel speed low while traveling in reverse.

- NOTE -

The mower may not travel straight in reverse. Slight adjustments may need to be made using the steering controls.

To steer left while traveling in reverse, allow the left steering control lever to move forward. The further the control is allowed to move forward, the quicker the mower will turn left.

To steer right while traveling in reverse, allow the right steering control lever to move forward. The further the control is allowed to move forward, the quicker the mower will turn right.

To stop the reverse travel, allow the steering control levers to return to the neutral position. If the mower is to be parked, place the handles in the neutral lock position and engage the parking brake.

4.8 ENGAGING THE DECK DRIVE (CUTTER BLADES)

1. Set the throttle at about 3/4 speed. Do not attempt to engage the deck drive at high speed as this shortens the electric clutch life — use only moderate engine speed when engaging the deck drive.
2. Engage the deck drive by pulling out on the yellow switch, located on the instrument panel, to the engage position. See Figure 4-6.

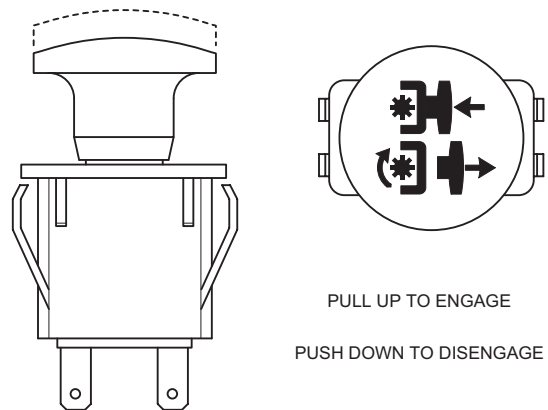

Figure 4-6. Cutter Engage Switch

- NOTE -

A squealing noise may be heard when engaging or disengaging the deck drive. It is caused by the electric clutch plates meshing as the mower comes up to speed. This is normal.

3. To disengage the deck drive, push the switch in to the disengage position.
4. Always operate the engine at full throttle to properly maintain cutting speed. If the engine starts to lug down, reduce the forward speed and allow the engine to operate at maximum RPM.

4.9 HILLSIDE OPERATION

WARNING

DO NOT operate on steep slopes. To check a slope, attempt to back up it (with the cutter deck down). If the machine can back up the slope without the wheels slipping, reduce speed and use extreme caution. Under no circumstances should the machine be operated on slopes greater than 15 degrees. See Figure 2-4, Page 8 to help determine approximate slope of area to be mowed. ALWAYS FOLLOW OSHA APPROVED OPERATION.

1. This mower has been designed for good traction and stability under normal mowing conditions. However, caution must be used when traveling on slopes, especially when the grass is wet. Wet grass reduces traction and steering control. The Roll-Over Protection System is standard equipment for this machine. See Section 2.6, page 6 of this manual for further details.
2. To prevent tipping or loss of control, do not start or stop suddenly, avoid unnecessary turns and travel at reduced speed. If tires lose traction, disengage blades and proceed slowly off the slope.
3. Avoid sudden starts when mowing uphill. Sudden starts may cause the machine to tip backwards.
4. Stay two cut widths away from slopes, drop offs, ditches, water and retaining walls.
5. Loss of traction may occur when traveling down hill. Weight transfers to the front of the machine and may cause the drive wheels to slip causing loss of braking or steering.
6. Keep tires properly inflated.

4.10 PARKING THE MOWER

1. Park the machine on a flat, level surface only. Do not park the machine on an incline.
2. Place the steering control levers in the neutral position.
3. Disengage the cutter blades.
4. Slow the engine to idle speed.
5. Engage the parking brake.
6. Turn the ignition key to the OFF position and remove the key.

4.11 AFTER OPERATION

1. Wash the entire mower after each use. Do not use high pressure spray or direct the spray onto electrical components.

- IMPORTANT -

Do not wash a hot or running engine. Cold water will damage the engine. Use compressed air to clean the engine if it is hot.

2. Keep the entire mower clean to inhibit serious heat damage to the engine or hydraulic oil circuit.
3. Check the drive belts for proper alignment and any signs of wear. Correct and adjust if necessary.

DANGER

To avoid injury from burns, allow the mower to cool before removing the fuel tank cap and refueling.

4. After the mower has cooled down, fill the fuel tank with fresh, clean fuel at the end of every day of operation. See Engine Owner's Manual for proper octane requirements.
5. Check the tire pressure. Adjust pressure if necessary.

4.12 REMOVING CLOGGED MATERIAL

DANGER

ROTATING BLADES

NEVER PUT YOUR HANDS INTO THE DISCHARGE CHUTE FOR ANY REASON!

Shut off the engine and remove the key and only then use a stick or similar object to remove material if clogging has occurred.

1. If the discharge chute becomes clogged, shut off the engine and remove the ignition key. Using a stick or similar item, dislodge the clogged material. Then resume normal mowing.

Section 4

4.13 MOVING MOWER WITH ENGINE STOPPED

To “free-wheel” or move the mower around without the engine running, rotate the dump valve counter-clockwise. See Figure 4-7. Disengage the parking brake and move the mower by hand. When the machine is in the desired position, engage the parking brake and rotate clockwise until they stop. The dump valves must be returned to the DRIVE position and torqued to 10ft/lbs to drive the mower.

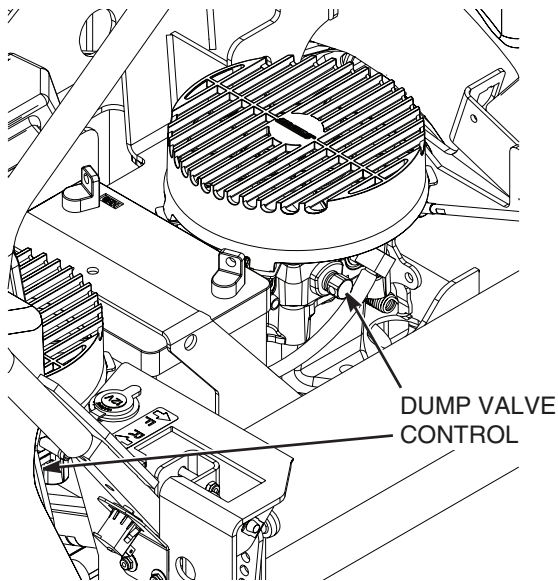

Figure 4-7. Dump Valve Control

4.14 RECOMMENDATIONS FOR MOWING

1. Do not mow with dull blades. A dull blade will tear grass, resulting in poor lawn appearance and reduced mowing power.
2. The discharge chute must not be removed and must be kept in the lowest position to deflect grass clippings and thrown objects downward. Direct the side discharge away from sidewalks or streets to minimize cleanup of clippings. When mowing close to obstacles, direct the discharge away from the obstacles to reduce the chance of property damage by thrown objects.
3. Cut grass when it is dry and not too tall. Do not cut grass too short (cut off 1/3 or less of existing grass for best appearance). Mow frequently.
4. Keep mower and discharge chute clean.
5. When mowing wet or tall grass, mow the grass twice. Raise the mower to the highest setting for the first pass and then make a second pass to the desired height.
6. Use a slow travel speed for trimming purposes.
7. Operate the engine at full throttle for best cutting. Mowing with a lower RPM causes the mower to tear the grass. The engine is designed to be operated at full speed.
8. Use the alternate stripe pattern for best lawn appearance. Vary the direction of the stripe each time the grass is mowed to avoid wear patterns in the grass.



WARNING

DO NOT operate without Discharge Chute, Mulching Kit, or entire Grass Catcher properly installed.

2. The discharge chute must not be removed and must be kept in the lowest position to deflect grass clippings and thrown objects downward. Direct the side discharge away from sidewalks or streets to minimize cleanup of clippings. When mowing close to obstacles, direct the discharge away from the obstacles to reduce the chance of property damage by thrown objects.

4.15 ADJUSTING CUTTING HEIGHT

The mower deck can be adjusted from a height of 1 inch to 5 inches at 1/4-inch intervals. To adjust the cutting height:

⚠ WARNING

DO NOT adjust the cutting height with the mower blades rotating. Disengage the power to the cutter blades and then adjust cutting height.

1. Disengage the power to the cutter blades.
2. Push the cutting height adjustment foot pedal all the way forward using your right foot until it locks in place. See Figure 4-8.

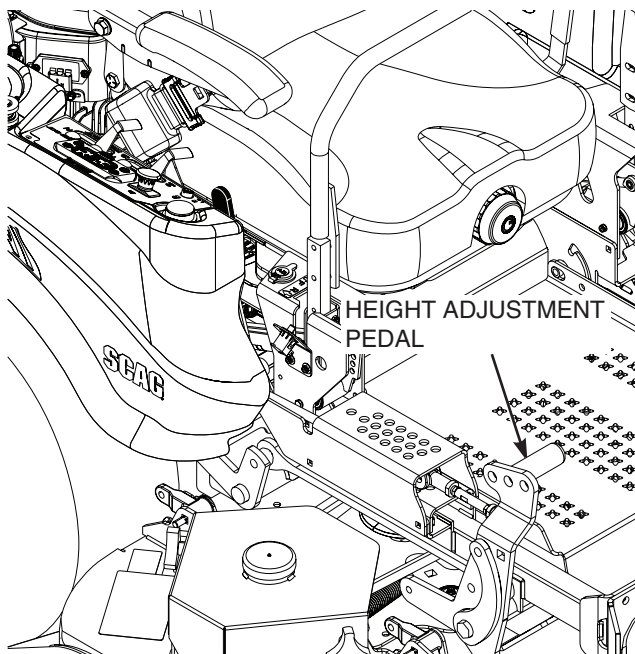

Figure 4-8. Adjusting Cutting Height

3. Insert the lanyard pin into the cutting height index at the desired cutting height. Push forward on the deck lift foot lever, hold in place and pull back on the deck release lever. See Figure 4-9. Slowly release the foot pedal. A deck height decal is located on the cutting height index as an aid in adjusting the deck to the desired height. See Figure 4-8.

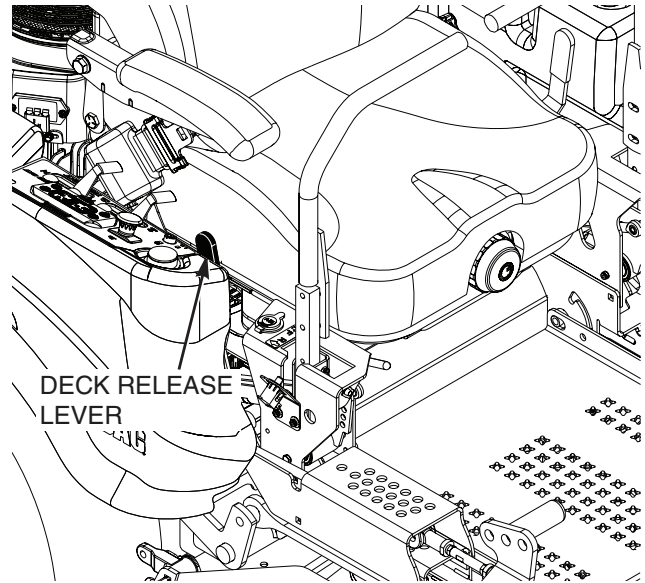
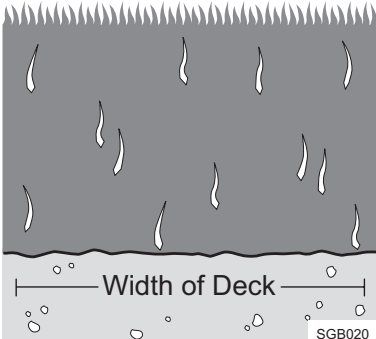
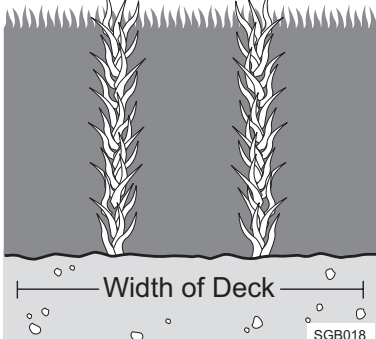
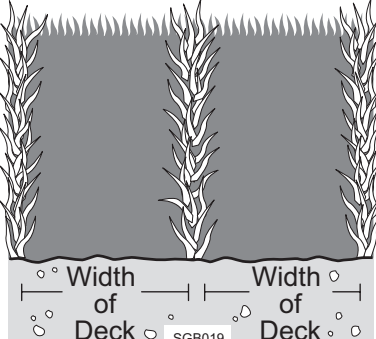

Figure 4-9. Deck Release Lever

4.16 TOWING (OPTIONAL HITCH ACCESSORY)

1. NEVER allow children or others in or on towed equipment.
2. Tow only with a machine that has a hitch designed for towing. Do not attach towed equipment except at the hitch point.
3. Follow manufacturer's recommendations for weight limit for towed equipment; 250/lbs. maximum towing weight.
4. NEVER tow on slopes. The weight of the towed equipment may cause loss of traction and loss of control.
5. Travel slowly and allow extra distance to stop.
6. Zero-turning with a trailer attached could cause damage to the trailer or mower.

TROUBLESHOOTING CUTTING CONDITIONS

CONDITION	CAUSE	CURE
<p>STRINGERS - OCCASIONAL BLADES OF UNCUT GRASS</p>  <p style="text-align: right; font-size: small;">SGB020</p>	Low engine RPM	Run engine at full RPM
	Ground speed too fast	Slow speed to adjust for conditions
	Wet grass	Cut grass after it has dried out
	Dull blades, incorrect sharpening	Sharpen blades
	Deck plugged, grass accumulation	Clean underside of deck
	Belts slipping	Adjust belt tension
<p>STREAKING - STRIPS OF UNCUT GRASS IN CUTTING PATH</p>  <p style="text-align: right; font-size: small;">SGB018</p>	Dull, worn blades	Sharpen blades
	Incorrect blade sharpening	Sharpen blades
	Low engine RPM	Run engine at full RPM
	Belt slipping	Adjust belt tension
	Deck plugged, grass accumulation	Clean underside of deck
	Ground speed too fast	Slow speed to adjust for conditions
	Wet grass	Cut grass after it has dried out
	Bent blades	Replace blades
<p>STREAKING - STRIPS OF UNCUT GRASS BETWEEN CUTTING PATHS</p>  <p style="text-align: right; font-size: small;">SGB019</p>	Not enough overlapping between rows	Increase the overlap of each pass

TROUBLESHOOTING CUTTING CONDITIONS (CONT'D)

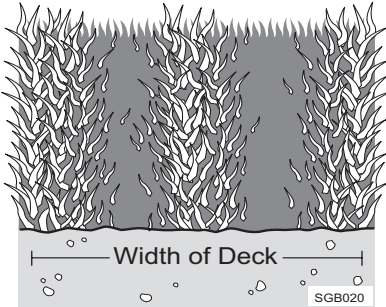
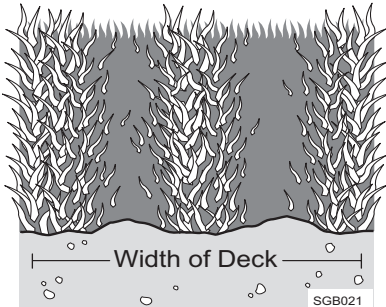
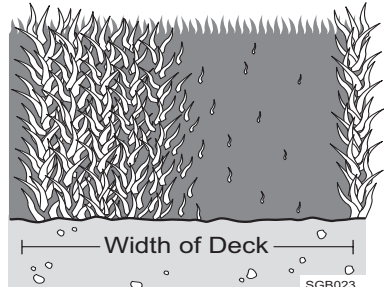
CONDITION	CAUSE	CURE
<p>UNEVEN CUT ON FLAT GROUND - WAVY HIGH-LOW APPEARANCE, SCALLOPED CUT, OR ROUGH CONTOUR</p>  <p>Width of Deck</p> <p>SGB020</p>	Lift worn from blade	Replace blade
	Blade upside down	Mount with cutting edge toward ground
	Deck plugged, grass accumulation	Clean underside of deck
	Too much blade angle (deck pitch)	Adjust pitch and level
	Deck mounted improperly	See your authorized SCAG dealer
	Bent spindle area	See your authorized SCAG dealer
	Dull blade	Sharpen blade
<p>UNEVEN CUT ON UNEVEN GROUND-WAVY APPEARANCE, HIGH-LOW SCALLOPED CUT, OR ROUGH CONTOUR</p>  <p>Width of Deck</p> <p>SGB021</p>	Uneven ground	May need to reduce ground speed, raise cutting height, and/or change direction of cut
<p>SLOPING RIDGE ACROSS WIDTH OF CUTTING PATH</p>  <p>Width of Deck</p> <p>SGB023</p>	Tire pressures not equal	Check and adjust tire pressure
	Wheels uneven	Check and adjust tire pressure
	Deck mounted incorrectly	See your authorized SCAG dealer
	Deck not level side-to-side	Check for level and correct

TROUBLESHOOTING CUTTING CONDITIONS (CONT'D)

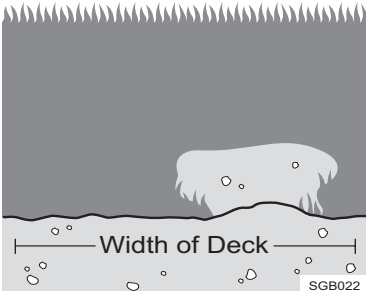
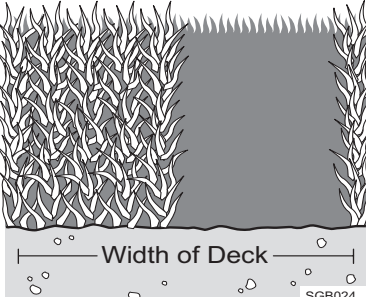
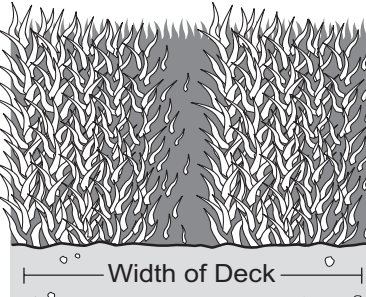
CONDITION	CAUSE	CURE
<p>SCALPING - BLADES HITTING DIRT OR CUTTING VERY CLOSE TO THE GROUND</p> 	Low tire pressures	Check and adjust pressures
	Ground speed too fast	Slow speed to adjust for conditions
	Cutting too low	May need to reduce ground speed, raise cutting height, change direction of cut, and/or change pitch and level
	Rough terrain	May need to reduce ground speed, raise cutting height, and/or change direction of cut
	Ground speed too fast	Slow speed to adjust for conditions
	Wet grass	Cut grass after it has dried out
<p>STEP CUT - RIDGE IN CENTER OF CUTTING PATH</p> 	Blades not mounted evenly	Adjust pitch and level
	Bent blade	Replace blade
	Internal spindle failure	See your authorized SCAG dealer
	Mounting of spindle incorrect	See your authorized SCAG dealer
<p>SLOPE CUT - SLOPING RIDGES ACROSS WIDTH OF CUTTING PATH</p> 	Bent spindle mounting area	See your authorized SCAG dealer
	Internal spindle failure	See your authorized SCAG dealer
	Bent deck housing	See your authorized SCAG dealer

ADJUSTMENTS

6.1 PARKING BRAKE ADJUSTMENT

WARNING

Do not operate the mower if the parking brake is not operable. Possible severe injury could result.

The parking brake linkage should be adjusted whenever the parking brake lock latch is placed in the “ENGAGE” position and the parking brake will not prevent the mower from moving. If the following procedures do not allow you to engage the parking brake properly, contact your Scag dealer for further brake adjustments.

1. Park the machine on a flat surface and block the caster wheels to prevent the machine from moving. Remove the ignition key.
2. Engage the parking brake. Fully depress the brake pedal and pull the parking brake lock latch back to lock the parking brake. See Figure 6-1.
3. Loosen the jam nut at the front of the brake linkage. See Figure 6-2.
4. With the parking brake in the locked position, turn the adjustment nut until the brake spring has an overall length of 2". See Figure 6-2.
5. Repeat steps 3 and 4 on the other side of the machine.
6. Test the parking brake.

- NOTE -

If this procedure does not achieve proper brake adjustment, please contact your authorized Scag dealer.

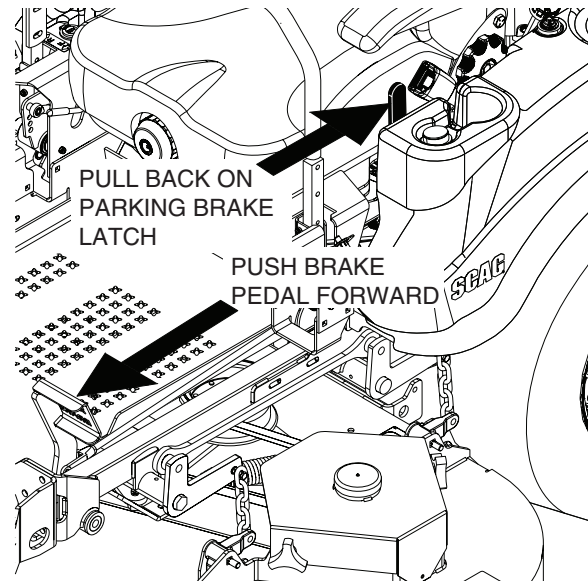

Figure 6-1. Brake Adjustment

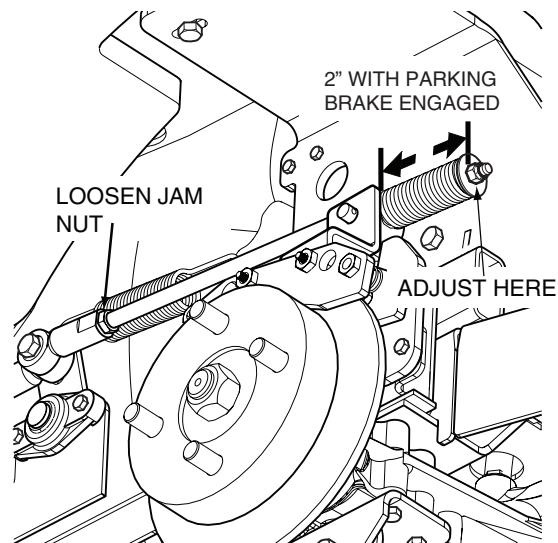

Figure 6-2. Brake Rod Adjustment

6.2 TRAVEL ADJUSTMENTS

Neutral or tracking adjustments will need to be made if:

- A. The steering control levers are in the neutral position and the machine creeps forward or backward. (Neutral Adjustment, See Page 26).
- B. The steering control levers are in the full forward position and the mower pulls to one side or the other when traveling in a forward direction. (Tracking Adjustment, See Page 26).

Section 6

NEUTRAL ADJUSTMENT

1. Be sure the dump valve levers are in the run position and the steering control levers are in the neutral lock position.
2. With an operator in the seat, start the engine and disengage the parking brake.
3. Run the engine at full operating speed and check if the machine creeps forward or backwards.
4. Adjust the RH wheel by loosening the jam nuts on the steering control rod and turning the rod until the drive wheel turns in the forward direction. Turn the rod back until the drive wheel stops moving. Turn the rod an additional 1/2 turn. See Figure 6-3.

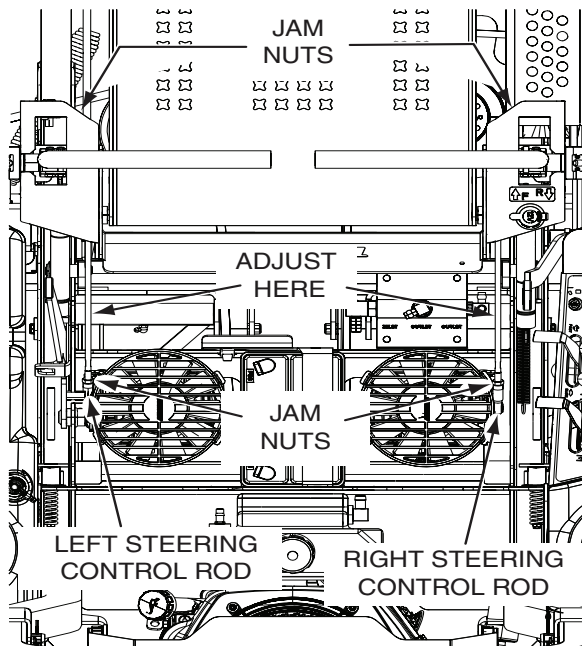

Figure 6-3. Steering Control Rod Adjustment

5. Tighten the jam nuts and repeat for the LH wheel. See Figure 6-3.
6. Actuate the steering control levers forward and reverse several times and return them to the neutral position.
7. Check that the drive wheels remained in neutral and readjust if necessary.
8. Check that the steering control levers hit the stop before the pumps reach full stroke. Adjust as needed.

TRACKING ADJUSTMENT

CAUTION

Stop the engine and remove the key from the ignition before making any adjustments. Wait for all moving parts to come to a complete stop before beginning work.

CAUTION

The engine and drive unit can get hot during operation causing burn injuries. Allow engine and drive components to cool before making any adjustments.

- NOTE -

Before proceeding with this adjustment, be sure that the caster wheels turn plus pivot freely and that the tire pressure in the drive wheels is correct. If the tire pressure is not correct, the machine will pull to the side with the lower pressure.

1. If at full speed the mower pulls right, it is an indication that the left wheel is turning faster than the right wheel. To adjust this condition, proceed as follows:
 - A. Stop the machine and place the steering control levers in the neutral position. Turn the tracking adjustment bolt for the LH pump inward (clockwise). This will cause the control rod to stroke the LH pump less, slowing down the LH wheel. See Figure 6-4.
2. If at full speed the mower pulls left, it is an indication that the right wheel is turning faster than the left wheel. To adjust this condition, proceed as follows:
 - A. Stop the machine and place the steering control levers in the neutral position. Turn the tracking adjustment bolt for the RH pump inward (clockwise). This will cause the control rod to stroke the RH pump less, slowing down the RH wheel. See Figure 6-4.

- NOTE -

If after making the adjustment as outlined in step 2A, the machine creeps forward or backward, perform the neutral adjustment. See Neutral Adjustment on page 26.

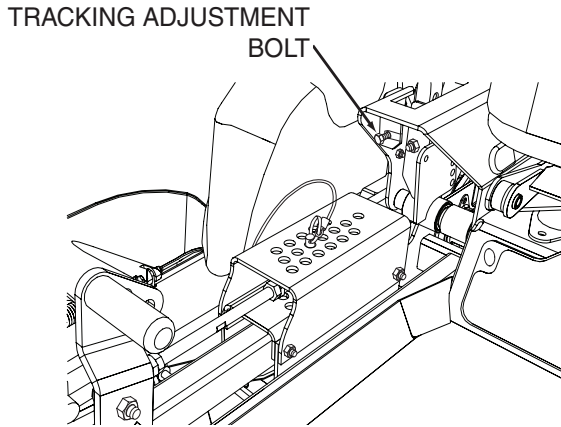

Figure 6-4. Tracking Adjustment

6.3 THROTTLE CONTROL AND CHOKE ADJUSTMENTS

These adjustments must be performed by your Scag dealer to ensure proper and efficient running of the engine. Should either need adjustment, contact your authorized Scag service center.

6.4 BELT ADJUSTMENT

⚠ WARNING

Before removing any guards, shut the engine off and remove the ignition key.

All drive belts are spring loaded and self-tensioning, however after the first 2, 4, 8 and 10 hours of operation, the belts should be checked for proper alignment and wear. Thereafter, check the belts after every 40 hours of operation or weekly, whichever occurs first.

⚠ WARNING

If the pump drive belt fails, steering control will be lost which could result in serious injury or death. Replace the pump drive belt as needed or every 400 hours / 2 years, whichever occurs first.

6.5 BELT ALIGNMENT

Belt alignment is important for proper performance of your Scag mower. If you experience frequent belt wear or breakage, see your authorized Scag service center for belt adjustment.

6.6 CUTTER DECK ADJUSTMENTS

Cutter deck level, pitch and height are set at the factory. However, if these adjustments should ever need to be made, the following procedures will aid in obtaining the proper cutter deck adjustment.

- NOTE -

Before proceeding with the cutter deck adjustments, be sure that all tires are properly inflated.

CUTTER DECK LEVEL

The cutter deck should be level from side-to-side for proper cutting performance. To check for level, be sure that the mower is on a flat, level surface, the tires are properly inflated and the cutter deck is set at the most common cutting height that you will use. On the RH side of the machine, check the distance from the top of the cutter deck to the floor. Next check the distance from the top of the cutter deck to the floor on the LH side of the machine. Both measurements should be the same. If the two measurements are different, the cutter deck level must be adjusted as follows:

1. If the cutter deck is lower on one side, loosen the elastic stop nuts securing the deck level links on the front and rear of the lower side. See Figure 6-5.

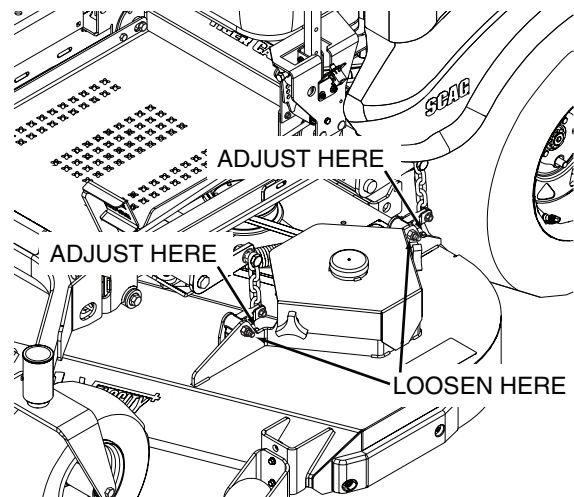

Figure 6-5. Cutter Deck Level Adjustment

Section 6

- Turn the adjustment bolts on the front and rear deck level links clockwise until the cutter deck is level between both sides. See Figure 6-5.
- Tighten the two (2) elastic stop nuts to secure the cutter deck in the proper position.

CUTTER DECK PITCH

The pitch of the cutter deck should be equal between the front and rear of the cutter deck for proper cutting performance. To check for proper deck pitch, be sure that the mower is on a flat, level surface and the tires are properly inflated.

Check the distance from the top of the cutter deck to the floor at the rear RH side of the cutter deck directly behind the cutter deck hanging chains. Next check the distance from the top of the cutter deck to the floor at the front RH side of the cutter deck directly in front of the cutter deck hanging chains. The measurement at the front of the cutter deck should be the same as the rear of the deck. Make these measurements at the LH side of the cutter deck also. If the measurement at the front of the deck is not the same, the cutter deck pitch must be adjusted as follows:

- Loosen the elastic stop nuts securing the deck level links on the front of the cutter deck on both sides. See Figure 6-6 and 6-7.

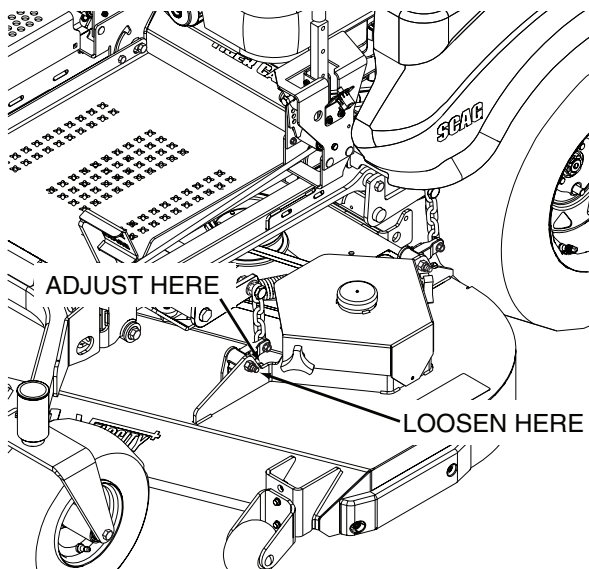

Figure 6-6. Cutter Deck Pitch Adjustment

- Turn the adjustment bolts on both sides either clockwise to raise or counter-clockwise to lower the front of the cutter deck until the measurements are equal. Tighten the elastic stop nuts.

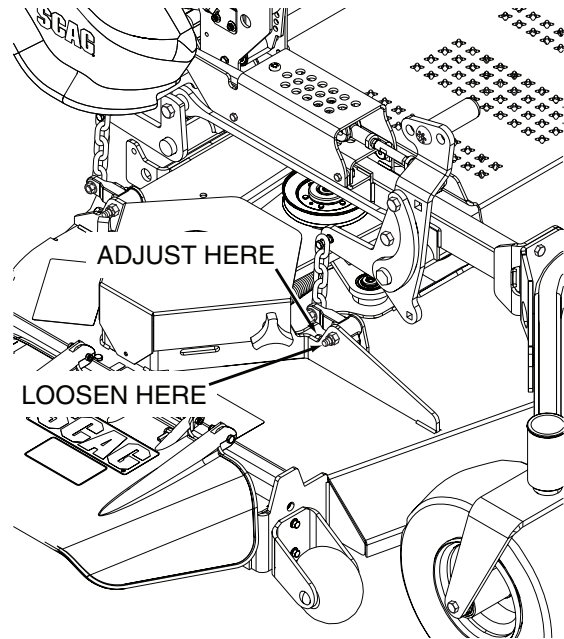

Figure 6-7. Cutter Deck Pitch Adjustment

- NOTE -

To prevent the cutter deck from teetering, all four (4) cutter deck hanging chains must have tension on them. If all four chains do not have tension on them and the deck teeters, you must readjust the cutter deck as outlined in the procedures above. All measurements should be taken from the top edge of the deck as the deck has an uneven bottom edge.

CUTTER DECK HEIGHT

The cutter deck height adjustment is made to ensure that the cutter deck is cutting at the height indicated on the cutting height index gauge. To check for proper deck height, be sure that the mower is on a flat, level surface and the tires are properly inflated.

- Check the cutter deck cutting height by placing the lanyard pin in the 4-1/2" position on the cutting height index. Release the deck from the transport position and allow the deck to move to the 4-1/2" cutting height position.
- Check the measurement from the floor to the cutter blade tip. If the measurement is not at 4-1/2", an adjustment can be made using the deck height control rod.
- Loosen the jam nuts on both ends of the deck height control rod. See Figure 6-8.

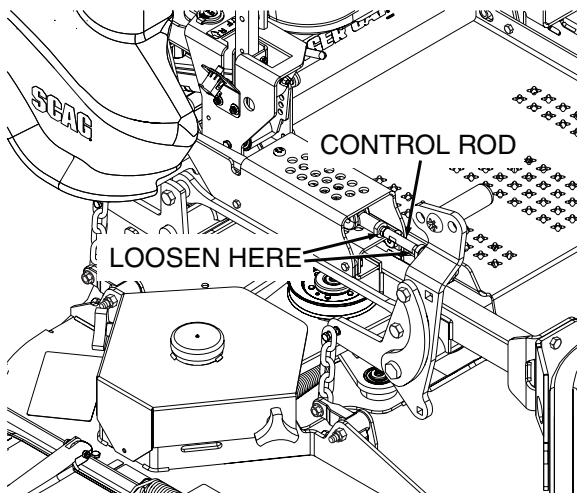

Figure 6-8. Cutter Deck Height Adjustment

4. Turn the control rod (See Figure 6-8) until the measurement from the floor to the cutter blade tip is at 4-1/2". Tighten the jam nuts on the control rod.

- NOTE -

If an adjustment had to be made, be sure that the cutter deck can easily be locked into the transport position.

6.7 CUSTOM-CUT BAFFLE ADJUSTMENT

The Custom-Cut Baffle is designed to deliver optimum airflow and superior cutting performance in any type of grass. The Custom-Cut Baffle can be raised or lowered to precisely tailor the deck's performance for the type of grass being cut. The baffle can be set in seven (7) different positions for optimum performance.

- A. 3-1/2" or 3-3/4" Position - (See Figure 6-9). For very tall, wiry or tough-to-cut grass.
- B. 4" (factory setting), 4-1/4" or 4-1/2" Position - (See Figure 6-9). For general purpose cutting. This gives the best mix of cutting performance in all types of grass.
- C. 4-3/4" or 5-1/4" Position - (See Figure 6-9). Placing the baffle in either the 4-3/4" or 5-1/4" setting will enhance fall cutting (leaf pickup) and reduce cutter deck "blowout".

To adjust the Custom-Cut Baffle height:

1. Place the cutter deck in the transport position.
2. Remove the hardware securing the Custom-Cut Baffle to the cutter deck.

- NOTE -

Hardware location used in the illustrations are for reference only. Location of hardware may vary depending on cutter deck size.

3. Move the Custom-Cut Baffle to desired position. See Figure 6-9.
4. Reinstall the mounting hardware. Torque hardware to 39 ft-lbs.

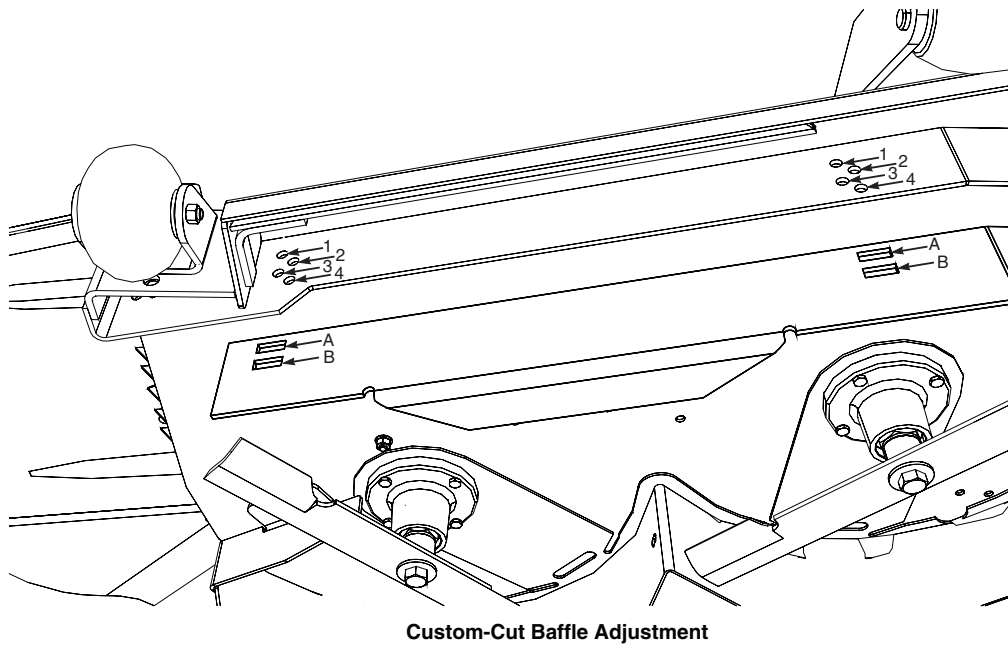

Custom-Cut Baffle Adjustment

Mounting Slot Selected	Mounting Hardware Location			
	Hole 1	Hole 2	Hole 3	Hole 4
Slot "A"				
Height (inches)	3-3/4"	4-1/4"	4-3/4"	5-1/4"
Slot "B"				
Height (inches)		3-1/2"	4"	4-1/2"

Figure 6-9. 7-Position Custom-Cut Baffle Adjustment

6.8 ELECTRIC CLUTCH ADJUSTMENT

The electric clutch serves two functions in the operation of the mower. In addition to starting and stopping the power flow to the cutter blades, the clutch also acts as a brake to assist in stopping blade rotation when the PTO is switched off or the operator presence circuit is interrupted.

When the clutch is disengaged, the air gap between the armature and rotor must be adjusted to fifteen thousandths of an inch, 0.015, for proper operation. The airgap adjustment is made at three bolts on the clutch. There are three inspection windows, one next to each adjusting bolt. See Figure 6-10.

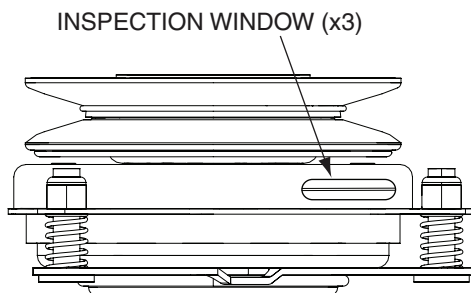

Figure 6-10. Clutch Air Gap Adjustment

1. Locate the inspection windows on the clutch.
2. Place a 0.015 feeler gauge in the slot between the rotor and the armature. See Figure 6-11.

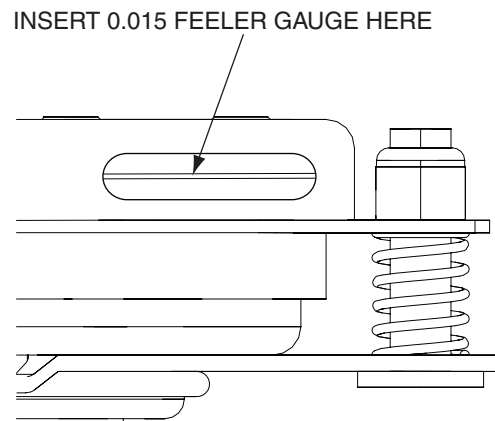

Figure 6-11. Clutch Air Gap Adjustment

3. Tighten or loosen the adjusting bolt as needed to achieve the 0.015 inch airgap. See Figure 6-12. Perform this operation at all three inspection windows.

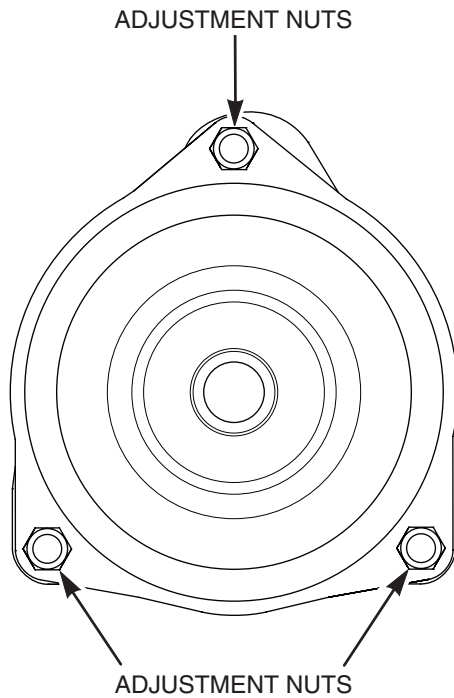

Figure 6-12. Clutch Air Gap Adjustment

This adjustment should be done every 500 hours of operation or annually, whichever comes first. In cases where the machine is heavily used, airgap settings should be checked more often.

If the air gap is too narrow, the clutch armature may drag when disengaged, resulting in premature failure.

If the air gap is too wide, the clutch may be slow to engage as the magnet must pull the armature in from a greater distance.

MAINTENANCE

7.1 MAINTENANCE CHART - RECOMMENDED SERVICE INTERVALS

BREAK-IN (FIRST 10)	HOURS						PROCEDURE	COMMENTS
	8	20	40	100	200	500		
X							Check all hardware for tightness	
X							Check hydraulic oil level	See paragraph 7.3
X							Check all belts for proper alignment	See paragraph 7.8
	X						Check hydraulic fittings and hoses for leaks	Use extreme caution when checking the hydraulic hoses. See paragraph 2.6
	X						Check engine oil level	See paragraph 7.4
	X						*Clean mower	See paragraph 7.13
	X						Check condition of blades	See paragraph 7.9
	X						Apply grease to fittings	See paragraph 7.2
	X						Check tire pressure	See paragraph 7.10
	X						Inspect seat belt for wear or damage	See paragraph 2.5
	X						Check the operator interlock system	See paragraph 4.2
		X					Change engine oil and filter	See paragraph 7.4
			X				Check battery electrolyte level clean battery posts and cables	See paragraph 7.7
			X				Check belts for proper alignment	See paragraph 7.8
			X				Inspect pump drive belt. Replace every 400 hours or 2 years, whichever comes first	See paragraph 6.4 & 7.8
			X				Check condition of fuel lines	
				X			Apply grease to fittings	See paragraph 7.2
				X			Change engine oil	See paragraph 7.4
				X			*Clean air cleaner element	See paragraph 7.6

* Perform these maintenance procedures more frequently under extreme dusty or dirty conditions

MAINTENANCE CHART - RECOMMENDED SERVICE INTERVALS (CONT'D)

BREAK-IN (FIRST 10)	HOURS					PROCEDURE	COMMENTS
	8	40	100	200	500		
				X		Apply grease to fittings	See paragraph 7.2
				X		Check hardware for tightness	
				X		Change engine oil filter	See paragraph 7.4
				X		Check hydraulic oil level	See paragraph 7.3
					X	Replace engine fuel filter	See paragraph 7.5
					X	Drain hydraulic system and replace hydraulic oil	Use SAE 20W50 Motor Oil. See paragraph 7.3
					X	Replace hydraulic oil filter	See paragraph 7.3
					X	Adjust electric PTO clutch	See paragraph 6.8

7.2 LUBRICATION

GREASE FITTING LUBRICATION CHART (SEE FIGURE 7-1)

LOCATION	LUBRICATION INTERVAL	LUBRICANT	NO. OF PLACES
1 Caster Wheel Pivot *	500 Hours/Yearly	Chassis Grease	2
2 Caster Wheel Bearings	100 Hours/Monthly	Chassis Grease	2
3 Cutter Deck Bellcranks	100 Hours/Bi-Weekly	Chassis Grease	4
4 Cutter Deck Pusharms	100 Hours/Bi-Weekly	Chassis Grease	2
5 Cutter Deck Spindle	40 Hours/Weekly	Spindle Grease	3

+ Compatible Greases: Scag Premium Chassis Grease p/n 486257
Scag Premium Spindle Grease p/n 486258

* **PROCEDURE:** Remove grease cap, part number 484195. Remove plug, part number 482028-01, and install grease zerk. Apply grease to the fitting until new grease appears at the top of the caster extension. Remove the grease zerk and reinstall the plug. Reinstall the grease cap. Special tool, part number 47007, is recommended for use in the installation of the grease cap.

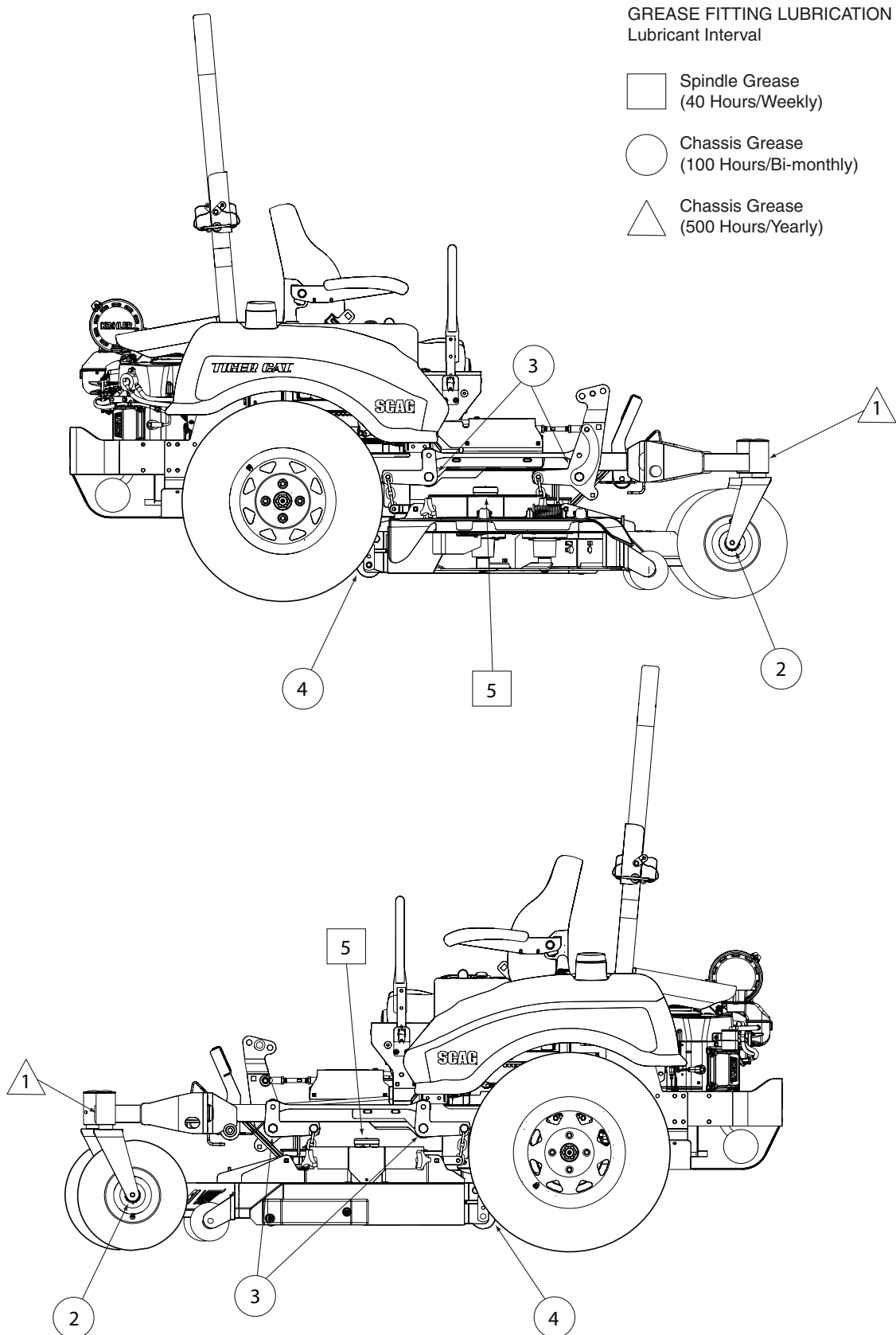

Figure 7-1. Lubrication Fitting Points

7.3 HYDRAULIC SYSTEM

A. CHECKING HYDRAULIC OIL LEVEL

The hydraulic oil level should be checked after the first 10 hours of operation. Thereafter, check the oil after every 200 hours of machine operation or monthly, whichever occurs first.

- IMPORTANT -

If the oil level is consistently low, check for leaks and correct immediately.

1. Tilt the seat forward to access the hydraulic oil reservoir. Wipe dirt and contaminants from around the reservoir cap. Remove the cap from the hydraulic oil reservoir.
2. Visually check the level of hydraulic oil. Hydraulic oil must be at least 2" inches from top of the filler neck. If the level cannot be determined visually, use a clean tape measure to check the level. If the fluid is low, add 20W50 motor oil (Scag p/n 486255 - 1 Quart or p/n 486254 - 1 Gallon). DO NOT overfill; (overfilling the oil reservoir may cause oil seepage around the cap area).
3. Clean the fill cap and install it onto the reservoir.

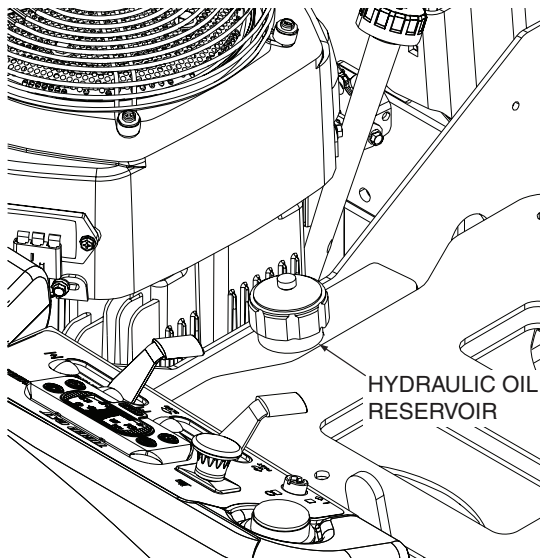

Figure 7-2. Hydraulic Oil Reservoir

B. CHANGING HYDRAULIC OIL

The hydraulic oil should be changed after every 500 hours or annually, whichever occurs first. The oil should also be changed if the color of the fluid has become black or milky. A black color and/or a rancid odor usually indicates possible overheating of the oil, and a milky color usually indicates water in the hydraulic oil.

- IMPORTANT -

The hydraulic oil should be changed if you notice the presence of water or a rancid odor to the hydraulic oil.

1. Park the mower on a level surface and stop the engine.
2. Place a suitable container under the hydraulic oil filter. Tilt the seat forward. Remove the fill cap from the reservoir and the drain plug from the bottom of the drain tee fitting on the front side of the filter base. See Figure 7-3. Allow the fluid to drain into the container and properly discard it.

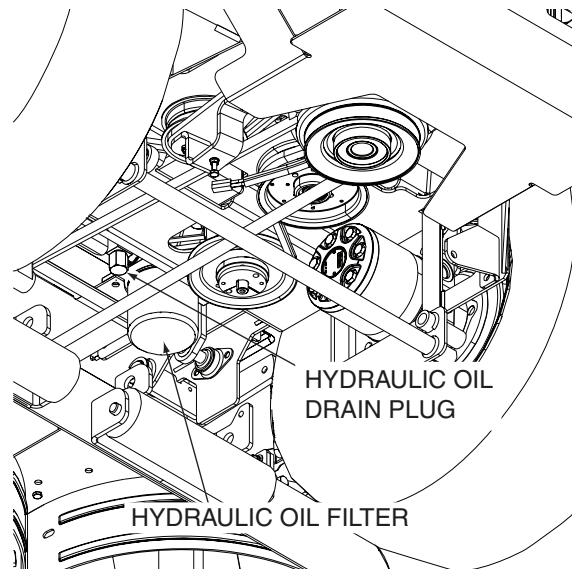

Figure 7-3. Hydraulic Oil Filter and Drain Plug

3. Re-install the drain plug into the tee fitting and be sure it is tight.

- NOTE -

Before refilling the hydraulic oil reservoir the hydraulic oil filter should be changed as outlined in Procedure C "Changing Hydraulic Oil Filter Element" on page 36.

Section 7

- Fill the reservoir to 2" inches from the top of the filler neck with 20W50 motor oil (Scag p/n 486255 - 1 Quart or p/n 486254 - 1 Gallon).
- Replace the reservoir fill cap. Start the engine and drive forward and backward for two minutes. Check the oil level in the reservoir. If necessary, add oil to the reservoir.

C. CHANGING HYDRAULIC OIL FILTER ELEMENT

The hydraulic oil filter should be changed after every 500 hours of operation or annually, whichever occurs first.

- Remove the oil filter element and properly discard it. See Figure 7-3. Fill the new filter with clean oil and install the filter. Hand tighten only.
- Run the engine at idle speed with the speed control lever in neutral for five minutes.
- Check the oil level in the hydraulic tank. It must be 2" inches from the top of the filler neck. If necessary, add SAE 20W50 motor oil (Scag p/n 486255 - 1 Quart or p/n 486254 - 1 Gallon).

7.4 ENGINE OIL

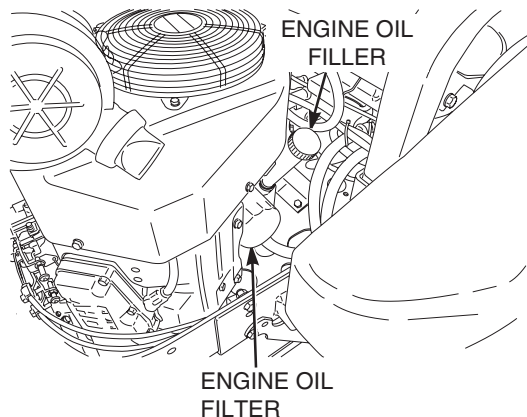

Figure 7-4. Kohler / Kawasaki Engine Oil Fill/Dipstick, and Filter Locations

A. CHECKING ENGINE CRANKCASE OIL LEVEL

The engine oil level should be checked after every 8 hours of operation or daily as instructed in the Engine Operator's Manual furnished with this mower.

B. CHANGING ENGINE CRANKCASE OIL

After the first 20 hours of operation, change the engine crankcase oil and replace the oil filter. Thereafter, change the engine crankcase oil after every 100 hours of operation or bi-weekly, whichever occurs first. Refer to the Engine Operator's Manual furnished with this mower for instructions.

C. CHANGING ENGINE OIL FILTER

After the first 20 hours of operation, replace the engine oil filter. Thereafter, replace the oil filter after every 200 hours of operation or every month, whichever occurs first. Refer to Engine Operator's Manual for instructions. See Figure 7-4

7.5 ENGINE FUEL SYSTEM

DANGER

To avoid injury from burns, allow the mower to cool before removing the fuel tank cap and refueling.

A. FILLING THE FUEL TANK

Fill to the bottom of the filler neck insert (approximately 5.3 gallons RH Fuel Tank and 5.7 Gallons LH Fuel Tank) at the beginning of each operating day. See Figure 7-5. Do not overfill. Use clean, fresh unleaded gasoline with a minimum octane rating of 87 and a maximum of 10% Ethanol.

DO NOT use E85 Fuel. Using E85 Fuel will cause severe damage to the engine.

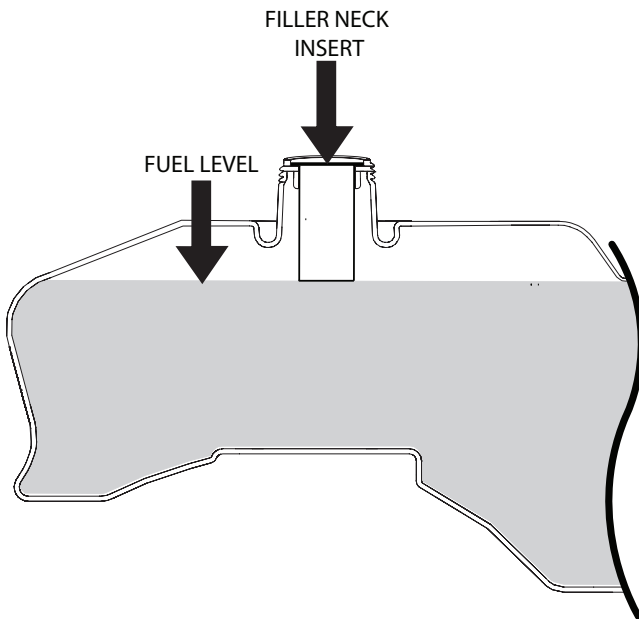

Figure 7-5. C.A.R.B. / EPA Phase 3 Fuel Level

To avoid personal injury or property damage, use extreme care in handling gasoline. Gasoline is extremely flammable and the vapors are explosive.

1. Extinguish all cigarettes, cigars, pipes and other sources of ignition.
2. Use only an approved gasoline container.
3. Never remove the gas cap or add fuel with the engine running. Allow the engine to completely cool before fueling.
4. Never fuel the machine indoors or in an enclosed trailer.
5. Never store the machine or fuel container where there is an open flame, spark or pilot light such as on a water heater or other appliances.
6. Never fill containers inside a vehicle or on a truck or trailer bed with a plastic liner. Always place containers on the ground away from your vehicle before filling.
7. Remove the machine from the truck or trailer and fuel on the ground. If this is not possible, then refuel the machine with a portable container, rather than from a gasoline dispenser nozzle.
8. Keep the nozzle in contact with the rim of fuel tank or container opening at all times until fueling is complete. Do not use a nozzle lock-open device.
9. If fuel is spilled on clothing, change clothing immediately and wash affected skin.

10. Replace gas cap and tighten until it ratchets.

B. REPLACING IN-LINE FUEL FILTER ELEMENTS

The engine fuel filter should be replaced after every 500 hours of operation or annually, whichever occurs first.

1. Close the shut-off valve.
2. Remove and replace the engine fuel filter. Open the fuel shut-off valve.

7.6 ENGINE AIR CLEANER

A. CLEANING AND/OR REPLACING AIR CLEANER ELEMENT

For any air cleaner, the operating environment dictates the air cleaner service periods. Inspect and clean the air cleaner element after every 100 hours of operation or bi-weekly, whichever occurs first and replace the element if required.

- NOTE -

In extremely dusty conditions it may be necessary to check the element once or twice daily to prevent engine damage.

1. Release the two latches securing the air cleaner cover to the air cleaner assembly and remove the cover. Set aside.
2. Remove the air cleaner and inspect.
3. Clean or replace the air cleaner and foam pre-cleaner as recommended by the engine manufacturer.
4. Replace the air cleaner cover and be sure to snap the two latches closed.

Section 7

7.7 BATTERY

WARNING

Lead-acid batteries produce flammable and explosive gases. To avoid personal injury when checking, testing or charging batteries, **DO NOT** use smoking materials near batteries. Keep arcs, sparks and flames away from batteries. Provide proper ventilation and wear safety glasses.

WARNING

Battery posts, terminals, and related accessories contain lead and lead compounds, chemicals known to cause cancer and reproductive harm. Wash hands after handling.

WARNING

Electric storage battery fluid contains sulfuric acid which is **POISON** and can cause **SEVERE CHEMICAL BURNS**. Avoid contact of fluid with eyes, skin, or clothing. Use proper protective gear when handling batteries. **DO NOT** tip any battery beyond 45° angle in any direction. If fluid contact does occur, follow first aid suggestions below.

BATTERY ELECTROLYTE FIRST AID

External Contact — Flush with water.

Eyes — Flush with water for at least 15 minutes and get medical attention immediately.

Internal — Drink large quantities of water. Follow with Milk Of Magnesia, beaten egg, or vegetable oil. Get medical attention immediately. In case of internal contact, **DO NOT** give fluids that would induce vomiting.

A. CHARGING THE BATTERY

Refer to the battery charger's manual for specific instructions.

Under normal conditions the engine's alternator will have no problem keeping a charge on the battery. If the battery has been completely discharged for a long period of time, the alternator may not be able to recharge the battery, and a battery charger will be required.

DO NOT charge a frozen battery. It may explode and cause injury. Let the battery warm before attaching a charger.

Whenever possible, remove the battery from the mower before charging and make sure the electrolyte covers the plates in all cells.

WARNING

BATTERIES PRODUCE EXPLOSIVE GASES. Charge the battery in a well ventilated space so gases produced while charging can dissipate.

Charging rates between 3 and 50 amperes are satisfactory if excessive gassing or spewing of electrolyte does not occur or the battery does not feel excessively hot (over 125°F). If spewing or gassing occurs or the temperature exceeds 125°F, the charging rate must be reduced or temporarily stopped to permit cooling.

B. JUMP STARTING

1. The booster battery must be a 12 volt type. If a vehicle is used for jump starting, it must have a negative ground system.
2. When connecting the jumper cables, connect the positive cable to the positive battery post, then connect the negative cable to the negative battery post.

7.8 DRIVE BELTS

All drive belts are spring-loaded and self-tensioning, however after the first 2, 4, 8 and 10 hours of operation, the belts should be checked for proper alignment and wear. Thereafter, check the belts after every 40 hours of operation or weekly, whichever occurs first.

- NOTE -

If you experience frequent belt wear or breakage, see your authorized Scag service center for belt adjustment.

WARNING

If the pump drive belt fails, steering control will be lost which could result in serious injury or death. Replace the pump drive belt as needed or every 400 hours / 2 years, whichever occurs first.

7.9 CUTTER BLADES

A. BLADE INSPECTION

1. Remove the ignition key before servicing the blades.
2. Raise the mower deck to the highest position. Place the lanyard pin in the highest cutting height position to prevent the cutter deck from falling.

WARNING

Always wear proper hand and eye protection when working with cutter blades.

3. Check the cutter blades for wear. If any part of the cutter blade is worn to 1/2 its original thickness, replace the cutter blade.

WARNING

Do not attempt to straighten a bent blade, and never weld a broken or cracked blade. Always replace it with a new blade to assure safety.

4. Check the cutter blades for gouges. If there are gouges on the top or bottom surfaces of the cutter blade, replace the cutter blade.
5. If a blade cutting edge is dull or nicked, it should be sharpened. Remove the blades for sharpening. See "Blade Replacement."

- NOTE -

Keep the blades sharp. Cutting with dull blades not only yields a poor mowing job, but slows the cutting speed of the mower and causes extra wear on the engine and the blade drive by pulling hard.

B. BLADE SHARPENING

- NOTE -

If possible, use a file to sharpen the blade. Using a wheel grinder may burn the blade.

- NOTE -

DO NOT sharpen the blades beyond 1/3 of the width of the blade. See Figure 7-6.

1. Sharpen the cutting edge at the same bevel as the original. See Figure 7-6. Sharpen only the top of the cutting edge to maintain sharpness.

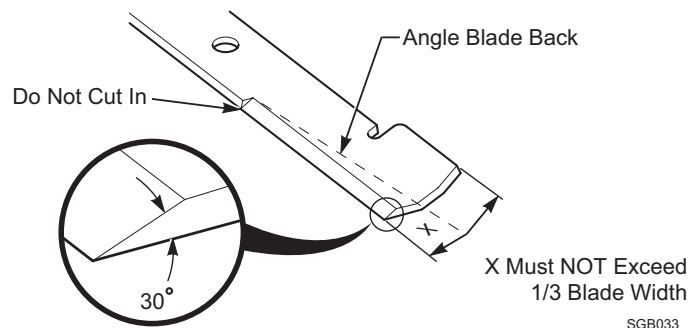

Figure 7-6. Blade Sharpening

2. Check the balance of the blade. If the blades are out of balance, vibration and premature wear can occur. The cutter blades should be balanced to 1-1/2 oz-in. See your authorized Scag dealer for blade balancing or special tools, if you choose to balance your own blades.

C. BLADE REPLACEMENT

WARNING

Always wear proper hand and eye protection when working with cutter blades.

1. Remove the ignition key before replacing the blades.

Section 7

2. Raise the mower deck to the highest position. Place the lanyard pin in the highest cutting height position to prevent the cutter deck from falling.
3. Secure the cutter blades to prevent them from rotating, (use the optional Blade Buddy tool P/N 9212, to assist in securing the cutter blades), remove the nut from the blade attaching bolt. Remove the cutter blade, bolt and spacer from the spindle shaft. See Figure 7-7.

- NOTE -

The front of the machine will have to be raised slightly to remove the blade bolt from the cutter spindle.

CAUTION

Inspect the cutter blade spacer(s) and washer for wear and/or cupping. Replace the worn parts. Worn spacer(s) and/or washer will not allow proper tightening of the cutter blade and can lead to cutter blade failure, personal injury or property damage.

4. To install the new cutter blade, put the flat washer onto the blade bolt and slide the bolt into the hole in the cutter blade.

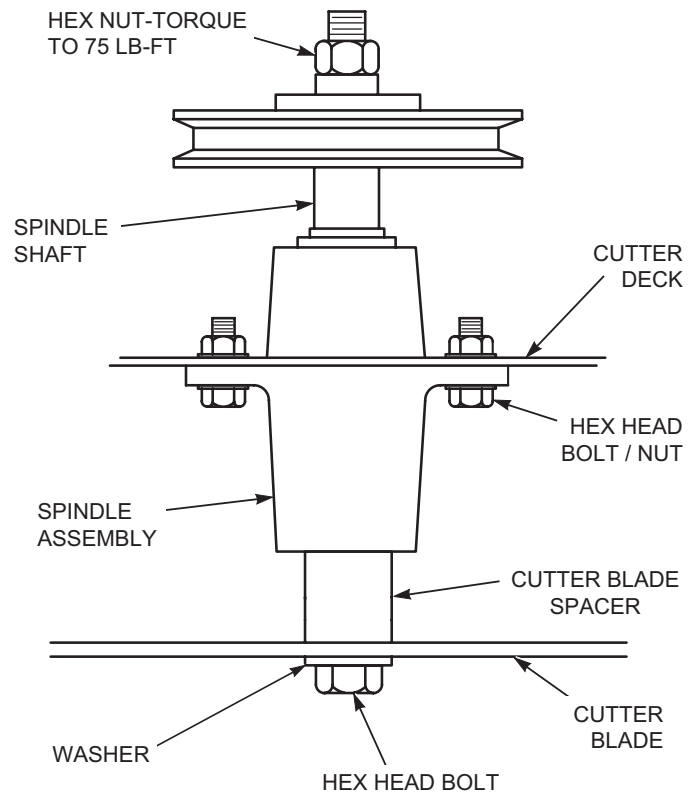

Figure 7-7. Blade Replacement

- NOTE -

Be sure that the blade is installed with the lift wing toward the top.

5. Install the spacer onto the blade bolt and insert the bolt into the cutter spindle shaft.
6. Install the hex nut to the blade bolt at the top of the cutter spindle. Secure the blades from rotating and torque to 75 ft/lbs. See Figure 7-7.

7.10 TIRES

Check the tire pressures after every 8 hours of operation or daily.

Caster Wheels	Flat Free
Drive Wheels	12 PSI

7.11 BODY, DECK, AND UPHOLSTERY **CAUTION**

Do not wash any portion of the equipment while it is hot. Do not wash the engine; use compressed air.

1. After each use, wash the mower and cutter deck. Use cold water and automotive cleaners. Do not use pressure cleaners.
2. Do not spray electrical components.
3. Use a mild soap solution or a vinyl/rubber cleaner to clean the seat.
4. Repair damaged metal surfaces using Scag touch-up paint available from your authorized Scag dealer. Wax the mower for maximum paint protection.

ILLUSTRATED PARTS LIST

8.1 SCAG APPROVED ATTACHMENTS AND ACCESSORIES.

Attachments and accessories manufactured by companies other than Scag Power Equipment are not approved for use on this machine.

Scag approved attachments and accessories:

- GC-3B - 901S (Requires a 901E, 48V/52V Install Kit) or (901F, 61V STCII Install Kit)
- GC-CS - 901T (Requires a 901E, 48V/52V Install Kit) or (901F, 61V STCII Install Kit)
- Mulch Plate - 9286 (48V), 9287 (52V), 9288 (61V)
- Hurricane Mulch - 9283 (48V), 9284 (52V), 9285 (61V)
- STCII Hitch - 922C
- STCII LED Lights - 923W
- OCDC - 922Z (48V), 923A (52V), 923B (61V)
- Tiger Striper - 923G (Requires a 923H Install Kit)
- Blade Buddy - 9212
- Quick-Fit Controls - 9289
- Air Filter Indicator (922U) - Available for Kawasaki 22FX, Briggs & Stratton 32BV
- 12" Chrome Wheel Covers - 920J (set of 2)

Scag Premium Lubricants:

- Chassis Grease (p/n 486257)
- Spindle Grease (p/n 486258)
- 20W50 Oil - Gallon (p/n 486254)
- 20W50 Oil - Quart (p/n 486255)

48V & 52V CUTTER DECKS

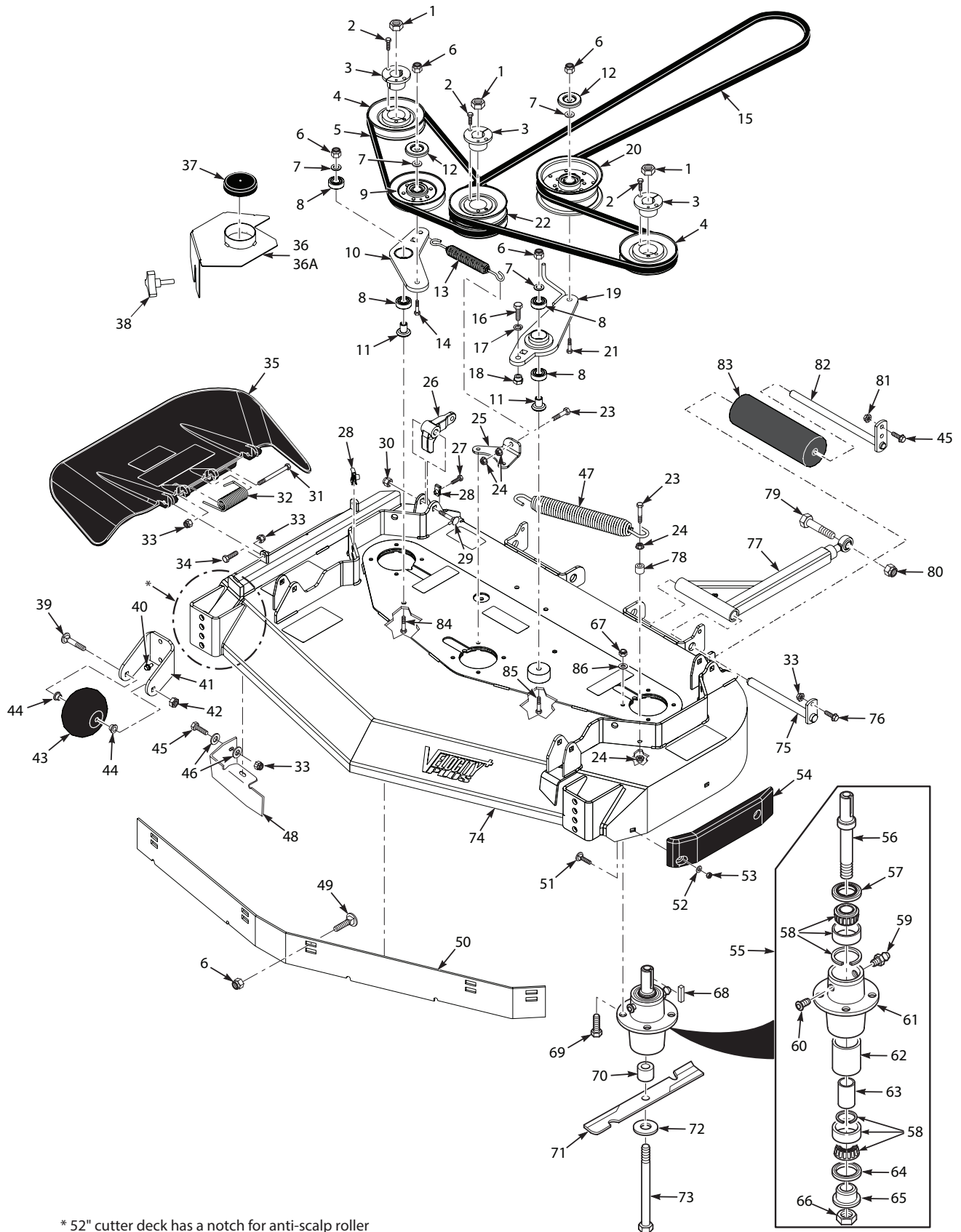

* 52" cutter deck has a notch for anti-scalp roller

Section 8

48V & 52V CUTTER DECKS

Ref. No.	Part No.	Description	48	52	Ref. No.	Part No.	Description	48	52
1	04020-09	Nut, 5/8-11 UNC	X	X	42	04021-05	Locknut, 3/8-16 Center Lock	X	X
2	04001-172	Bolt, Hex Head 1/4-20 x 1" Grade 8	X	X	43	481632	Anti-Scalp Wheel (INCL. #44)	X	X
3	48926	Hub, Tapered 1-1/8" Bore	X	X	44	48100-15	Bushing, .376 ID Oilite	X	X
4	483282	Pulley 4.75"	X		45	04001-09	Bolt, Hex Head 5/16-18 x 1"	X	X
	483284	Pulley 5.35"		X	46	04040-15	Flatwasher, 5/16"	X	X
5	483239	Belt, RH Cutter Deck	X		47	483246	Spring, Idler LH	X	X
	483240	Belt, RH Cutter Deck		X	48	424677	Turbo Baffle, Bolt On	X	X
6	04021-09	Nut, Elastic Stop 3/8-16	X	X		*425619	Turbo Baffle, 48V	X	
7	04043-04	Flatwasher, 3/8"	X	X		*424211	Turbo Baffle, 52V		X
8	48224	Bearing	X	X	49	04003-23	Bolt, Carriage 3/8-16 x 1"	X	X
9	48181	Pulley, Idler 5" Dia.	X	X	50	424839	Baffle Custom-Cut, 48V (7-Position)	X	
10	461946	Idler Arm (Incl. #8)	X	X		424840	Baffle Custom-Cut, 52V (7-Position)		X
11	43689	Idler Pivot	X	X	51	04003-12	Bolt, Carriage 5/16-18 x 3/4"	X	X
12	424367	Dust Shield	X	X	52	04040-04	Flatwasher, 5/16"	X	X
13	483247	Spring, Idler RH	X	X	53	04021-04	Nut, Center Lock 5/16-18	X	X
14	04001-45	Bolt, Hex Head 3/8-16 x 2"	X	X	54	483176	Wear Pad	X	X
15	486283	Belt, Cutter Deck Drive (48V)	X		55	461663	Spindle Assembly With Hardware	X	X
	486284	Belt, Cutter Deck Drive (52V)		X	56	43589	Shaft, Spindle	X	X
16	04001-27	Bolt, Hex Head 7/16-14 x 1"	X	X	57	481024	Seal Upper	X	X
17	04030-05	Lockwasher 7/16"	X	X	58	481022	Bearing Assembly	X	X
18	43686	Boss, Spring Anchor	X	X	59	48114-04	Grease Fitting	X	X
19	462503	Idler Arm (Includes 8)	X	X	60	48677	Valve, Grease Relief	X	X
20	483210	Pulley, Idler 5" Dia.	X	X	61	43644	Housing, Spindle	X	X
21	04001-54	Bolt, Hex Head 3/8-16 x 3"	X	X	62	43312	Spacer, Outside	X	X
22	483283	Pulley, Double Groove	X		63	43296	Spacer, Inside	X	X
	483285	Pulley, Double Groove		X	64	481025	Seal, Lower	X	X
23	04001-136	Bolt, Hex Head 3/8-16 x 1-1/2" Gr. 8	X	X	65	43297	Bushing, Bottom	X	X
24	04019-04	Nut, 3/8-16 Serrated Flange	X	X	66	481035	Nut, Special 1-1/16 - 18	X	X
25	424376	Bracket, Spring Anchor RH (48V)	X		67	04021-22	Nut, Elastic Stop 5/16-18 Grade 8	X	X
	424377	Bracket, Spring Anchor RH (52V)		X	68	04063-08	Key, 1/4 x 1/4 x 2"	X	X
26	485528	Lever, Deck Level	X	X	69	04001-176	Bolt, Hex Head 5/16-18 x 1-3/4" Gr. 8	X	X
27	04107-04	Bolt, Hex Head 3/8-16 x 2" Spec	X	X	70	43590	Spacer, Spindle	X	X
28	04110-03	U-Nut, 3/8-16	X	X	71	482877	Cutter Blade 16.5"	X	
29	04003-42	Bolt, Carriage 7/16-14 x 2-1/4"	X	X		482878	Cutter Blade 18"		X
30	04021-11	Nut, Elastic Stop 7/16-14	X	X	72	04043-06	Flatwasher, 5/8" Hardened	X	X
31	04001-154	Bolt, Hex Head 5/16-18 x 4-3/4"	X	X	73	04001-41	Bolt, Hex Head 5/8-11 x 9-1/2"	X	X
32	483378	Spring, Discharge Chute	X	X	74	462867	Cutter Deck Velocity Plus	X	
33	04021-10	Nut, Elastic Stop 5/16-18	X	X		462868	Cutter Deck Velocity Plus		X
34	04001-12	Bolt, Hex Head 5/16-18 x 1-3/4"	X	X	75	451240	Push Arm Shaft	X	X
35	461844	Discharge Chute Assy.	X		76	04001-09	Bolt, Hex Head 5/16-18 x 1"	X	X
	*462473	CA Discharge Chute, 48V	X		77	461516	Push Arm Assembly	X	X
	461845	Discharge Chute Assy.		X	78	43063	Spacer	X	X
	462475	CA Discharge Chute, 52V		X	79	04001-79	Bolt, Hex Head 5/8-11 x 4-1/2"	X	X
36	462480	Belt Cover Weldment RH (incl. #37)	X		80	04021-13	Nut, Elastic Stop 5/8-11	X	X
	462822	Belt Cover Weldment LH (incl. #37)	X		81	04117-01	Locknut, 5/16-18 Flange Hex Head	X	X
36A	462825	Belt Cover Weldment RH (incl. #37)		X	82	45944	Shaft, Roller	X	X
	462824	Belt Cover Weldment LH (incl. #37)		X	83	48038	Roller, Rear	X	X
37	484368	Cap, Spindle	X	X	84	04001-46	Bolt, Hex Head 3/8-16 x 2-1/4"	X	X
38	481625-01	Wing Nut, 3/8-16	X	X	85	04001-62	Bolt, Hex Head 3/8-16 x 3-1/4"	X	X
39	04003-26	Bolt, Carriage 3/8-16 x 4"	X	X	86	04030-03	Lockwasher 5/16"	X	X
40	04017-27	Bolt, Serrated Flange 3/8-16 x 1"	X	X					
41	422478	Bracket, Anti-Scalp Wheel	X	X					

* = California Models Only (not shown)

61V CUTTER DECK

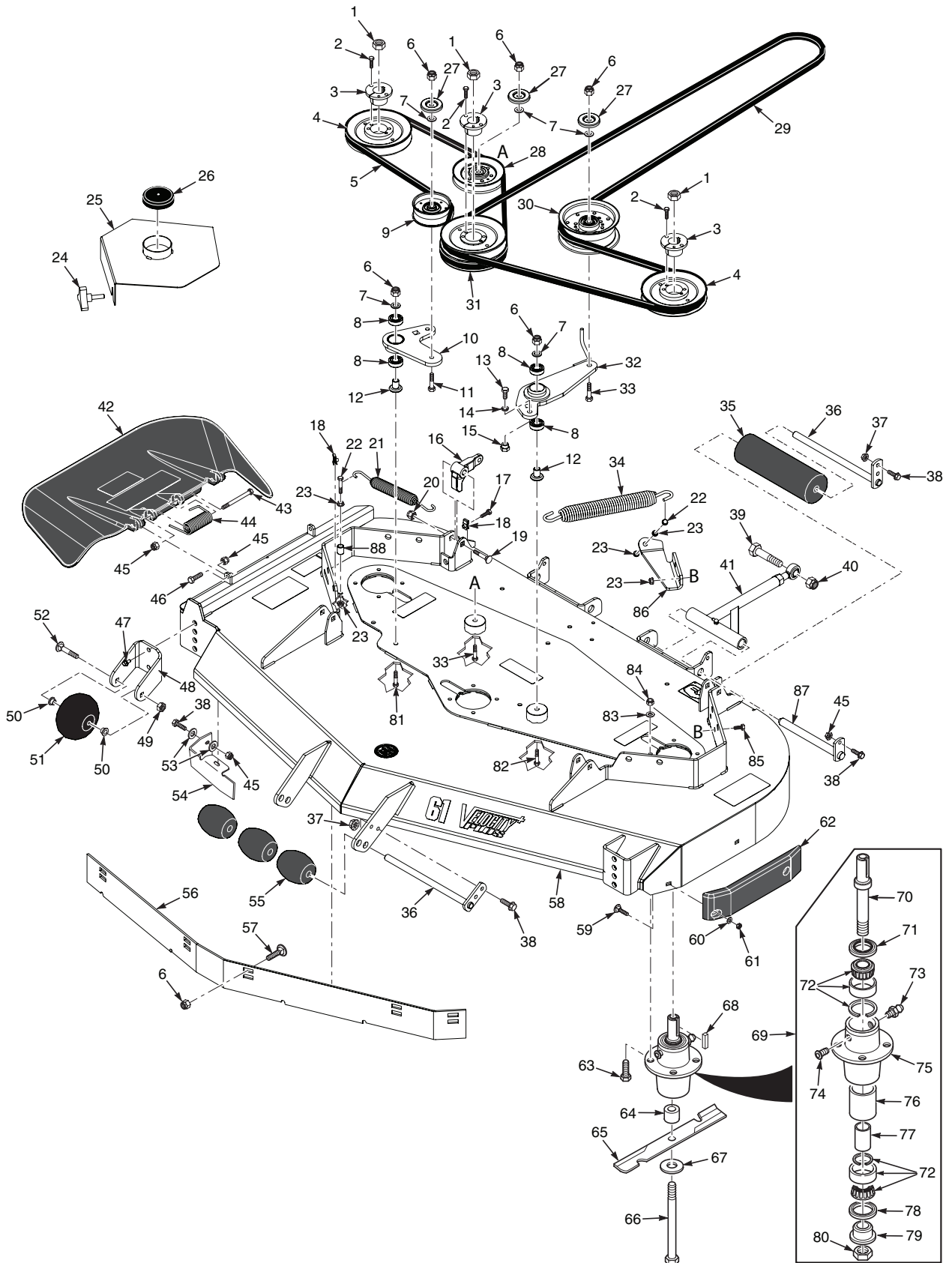

61V CUTTER DECK

Ref. No.	Part No.	Description
1	04020-09	Nut, 5/8-11 UNC
2	04001-172	Bolt, Hex Head 1/4-20 x 1" Grade 8
3	48926	Hub, Tapered 1-1/8" Bore
4	483286	Pulley, Tapered Bore 6.33" Dia.
5	483157	Belt, Deck Drive RH
6	04021-09	Nut, Elastic Stop 3/8-16
7	04043-04	Flatwasher, 3/8" - .938 x .391 x .105"
8	48224	Bearing
9	486045	Idler Pulley, 3-1/2" Dia.
10	462888	Idler Arm (Incl. #8)
11	04001-31	Bolt, Hex Head 3/8-16 x 2-1/2"
12	43689	Pivot, Idler Arm
13	04001-27	Bolt, Hex Head 7/16-14 x 1"
14	04030-05	Lockwasher 7/16"
15	43686	Boss, Spring Anchor
16	485528	Lever, Deck Level
17	04107-04	Bolt, Hex Head 3/8-16 x 2" Spec
18	04110-03	U-Nut, 3/8-16
19	04003-42	Bolt, Carriage 7/16-14 x 2-1/4"
20	04021-11	Nut, Elastic Stop 7/16-14
21	483703	Spring, RH Deck Drive
22	04001-136	Bolt, Hex Head 3/8-16 x 1-1/2" Gr.8
23	04019-04	Nut, Serrated Flange 3/8-16
24	481625-01	Wing Nut, 3/8-16
25	463229	Belt Cover Weldment (incl. #26)
26	484368	Cap, Spindle
27	424367	Dust Shield
28	48181	Idler Pulley, 5" Dia.
29	485845	Belt, Deck Drive 61V
30	483210	Idler Pulley, 5" Dia.
31	483287	Pulley, Double Groove 6.33" Dia.
32	462269	Idler Arm (Incl. #8)
33	04001-54	Bolt, Hex Head 3/8-16 x 3"
34	483246	Spring, LH Deck Drive
35	48038	Roller, Rear
36	45944	Shaft, Roller
37	04117-01	Locknut, 5/16-18 Flange Hex Head
38	04001-09	Bolt, Hex Head 5/16-18 x 1"
39	04001-79	Bolt, Hex Head 5/8-11 x 4-1/2"
40	04021-13	Nut, Elastic Stop 5/8-11
41	461516	Push Arm Assembly
42	461846	Discharge Chute Assy.
	*462477	CA Discharge Chute Assy.
43	04001-154	Bolt, Hex Head 5/16-18 x 4-3/4"

Ref. No.	Part No.	Description
44	483378	Spring, Discharge Chute
45	04021-10	Nut, Elastic Stop 5/16-18
46	04001-12	Hex Head 5/16-18 x 1-3/4"
47	04017-27	Bolt, Serrated Flange 3/8-16 x 1"
48	422478	Bracket, Anti-Scalp Wheel
49	04021-05	Locknut, 3/8-16 Center Lock
50	48100-15	Bushing, .376 ID Oilite
51	481632	Anti-Scalp Wheel
52	04003-26	Bolt, Carriage 3/8-16 x 4"
53	04040-15	Flatwasher 5/16"
54	424209	Turbo Baffle, Bolt On
	*425625	Turbo Baffle 61V
55	482295	Wheel, Anti Scalp
56	424841	Baffle Custom-Cut, 61V (7-Position)
57	04003-23	Bolt, Carriage 3/8-16 x 1"
58	462869	Cutter Deck Velocity Plus
59	04003-12	Bolt, Carr. 5/16-18 x 3/4"
60	04040-04	Flatwasher, 5/16-.344 x .688 x .065"
61	04021-04	Nut, Center Lock 5/16"
62	483176	Wear Pad
63	04001-176	Bolt, Hex Head 5/16-18 x 1-3/4" Grade 8
64	43590	Spacer, Spindle
65	482879	Cutter Blade 21"
66	04001-41	Bolt, Hex Head 5/8-11 x 9-1/2"
67	04043-06	Flatwasher, 5/8" Hardened
68	04063-08	Key, 1/4 x 1/4 x 2"
69	461663	Spindle Assembly With Hardware
70	43589	Shaft, Spindle
71	481024	Seal Upper
72	481022	Bearing Assembly
73	48114-04	Grease Fitting
74	48677	Valve, Grease Relief
75	43644	Housing, Spindle
76	43312	Spacer, Outside
77	43296	Spacer, Inside
78	481025	Seal, Lower
79	43297	Seal, Lower
80	481035	Nut, Special 1-1/16 - 18
81	04001-46	Bolt, Hex Head 3/8-16 x 2-1/4"
82	04001-62	Bolt, Hex Head 3/8-16 x 3-1/4"
83	04030-03	Lockwasher 5/16"
84	04021-22	Nut, Elastic Stop 5/16-18 Grade 8
85	04001-19	Bolt, Hex Head 3/8-16 x 1"
86	427023	Bracket, Spring Anchor
87	451240	Push Arm Shaft
88	43063	Spacer

* = California Models Only (not shown)

CUTTER DECK CONTROLS

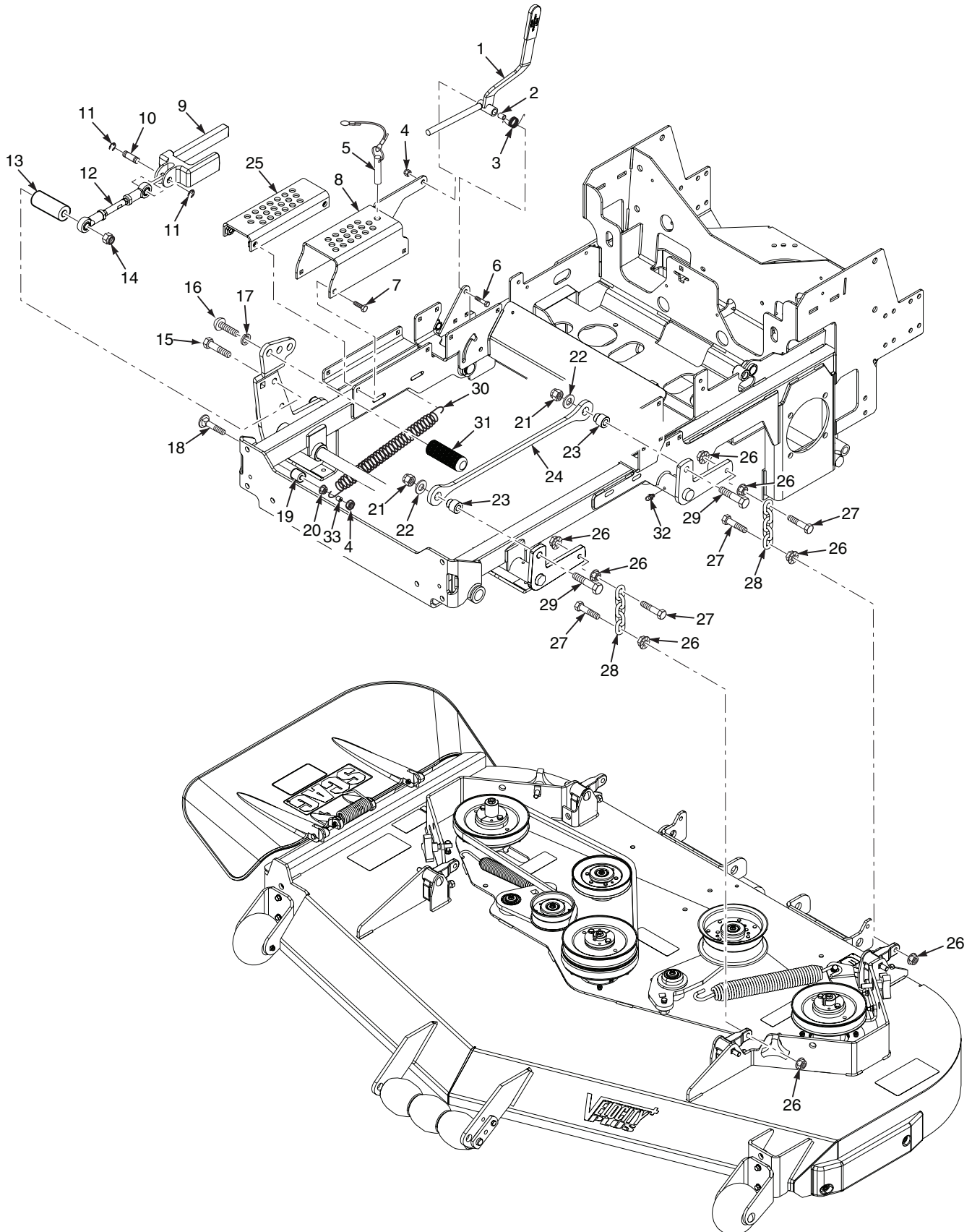

CUTTER DECK CONTROLS

Ref. No.	Part No.	Description
1	462839	Deck Latch Assembly (Includes Grip)
	485592	Grip, Deck Latch
2	43874	Spacer, Deck Latch
3	485704	Spring, Torsion - Lever Return
4	04021-05	Nut, Center Lock 3/8-16
5	483345	Pin Assembly, w/Lanyard
6	04001-31	Bolt, Hex Head 3/8-16 x 2-1/2"
7	04006-02	Bolt, Hex Wshr Head 5/16-18 x 1-1/4"
8	425737	Adjustment Bracket, Cutting Height
9	462872	Slide, Height Adjust (INCL. 10,11,12)
10	43487	Pin, Deck Lift
11	04050-18	Retaining Ring, 1/2" Ext.
12	482534	Linkage Assembly, Deck Lift
13	43873	Spacer, Deck Lift Pedal
14	04021-07	Nut, Elastic Stop 1/2-13
15	04001-87	Bolt, Hex Head 1/2-13 x 4"
16	04108-04	Capscrew, 5/8-11 x 1-1/2"
17	04030-07	Lockwasher, 5/8" Spring
18	04003-21	Bolt, Carriage 3/8-16 x 2-1/2"
19	43572	Spacer
20	04019-04	Nut, Serrated Flange 3/8-16
21	04021-07	Nut, Elastic Stop 1/2-13
22	04040-13	Flatwasher, 1/2-.562 x 1.375 x .109
23	431018	Pivot, Deck Link
24	428513	Link, Decklift (black)
25	452408	Adjustment Bracket, Lower Cut Height
26	04019-04	Nut, Serrated Flange 3/8-16
27	04001-20	Bolt, Hex Head 3/8-16 x 1-1/2"
28	482628	Chain
29	04001-153	Bolt, Hex Head 1/2-13 x 2-1/4"
30	483177	Spring, Decklift
31	424504	Foot Pedal, Height Adjustment
32	48114-04	Grease Fitting
33	43212	Spacer, Deck Assist
*	04059-01	Deck Height Stop

* = Item Not Shown

SHEET METAL COMPONENTS

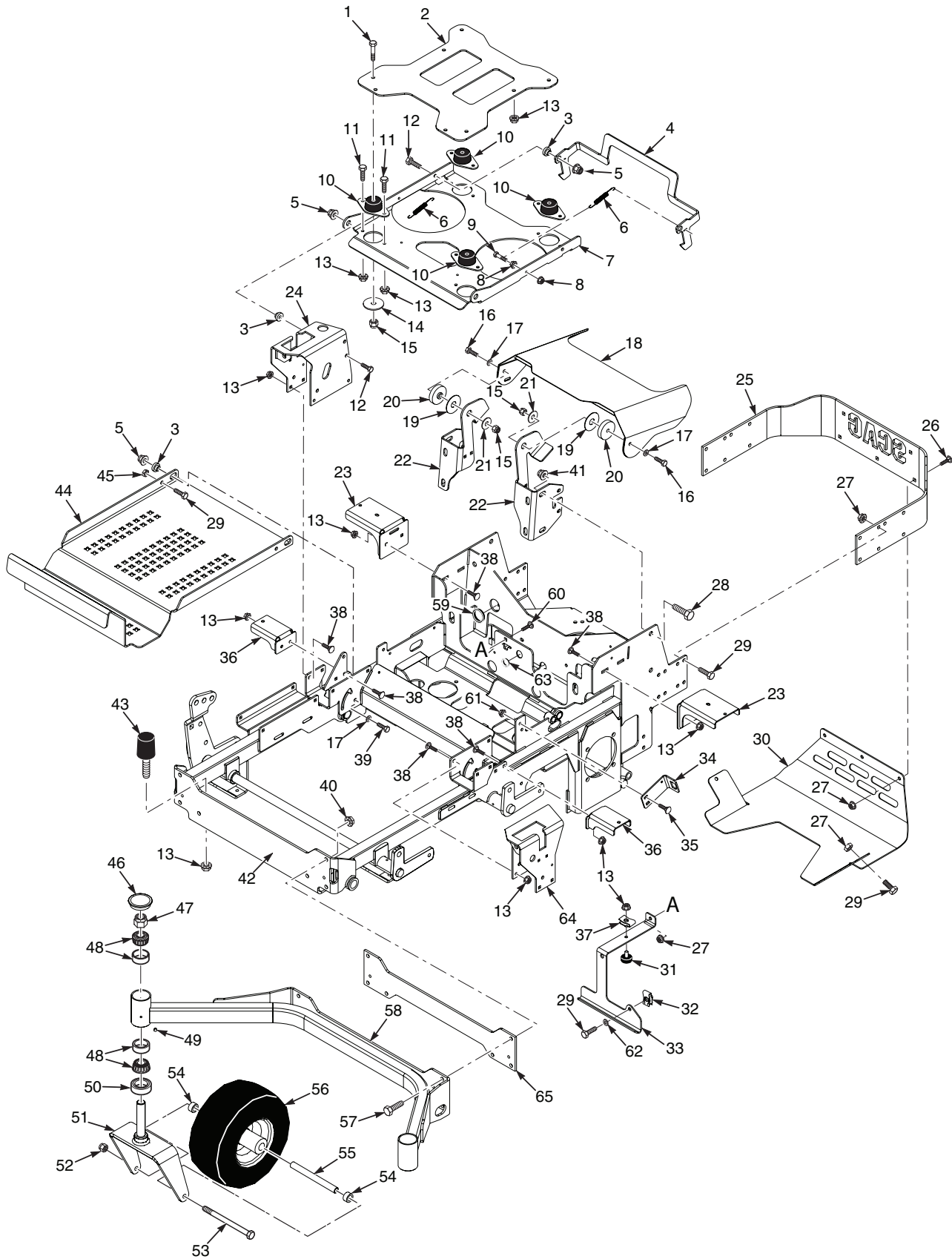

SHEET METAL COMPONENTS

Ref. No.	Part No.	Description
1	04001-46	Bolt, Hex Head 3/8-16 x 2-1/4"
2	462863	Seat Plate w/decal
3	43086	Bushing
4	426949	Seat Latch
5	04117-02	Nut, Elastic Flange 3/8-16
6	484498	Spring, Seat Latch
7	463106	Plate, Seat Mounting w/decals
8	04019-02	Nut, Serrated Flange 1/4-20
9	04001-59	Bolt, Hex Head 1/4-20 x 1-1/4"
10	484148	Isolator, Seat
11	04001-08	Bolt, Hex Head 5/16-18 x 3/4"
12	04001-32	Bolt, Hex Head 3/8-16 x 1-1/4"
13	04019-03	Nut, Hex Serr. Flng 5/16-18
14	04041-38	Flatwasher, 3/8-.406 x 2.25 x .1875
15	04021-09	Nut, Elastic Stop 3/8-16
16	04001-21	Bolt, Hex Head 3/8-16 x 1-3/4"
17	04041-07	Flatwasher, 3/8-.391 x .938 x .105
18	462838	Hood Assembly
19	483471	Disk, Anti-Friction
20	43740	Spacer, Hood
21	04041-11	Flatwasher, 3/8-.406 x 1.50 x 7 Ga.
22	427029	ROPS Mount, RH
	427178	ROPS Mount, RH, 32BV
	427028	ROPS Mount, LH
	427177	ROPS Mount, LH, 32BV
23	427063	Mounting Bracket, Fuel Tank Rear
24	463326	Control Plate w/decal, RH (black)
25	425725	Bumper, Rear
26	04003-23	Bolt, Carriage 3/8-16 x 1"
27	04019-04	Nut, 3/8-16 Serr. Flange
28	04001-70	Bolt, Hex Head 1/2-13 x 1-1/4"
29	04001-19	Bolt, Hex Head 3/8-16 x 1"
30	427032	Plate, Skid
31	481284	Bumper, Rubber

Ref. No.	Part No.	Description
32	04110-03	U-Nut, 3/8-16
33	427334	Battery Hold Down
34	425905	Mounting Bracket, Neutral Switch
35	04003-02	Bolt, Carriage 1/4-20 x 3/4"
36	425862	Mounting Bracket, Fuel Tank Front
37	48030-18	Clamp, Cable 1" Double
38	04003-12	Bolt, Carriage 5/16-18 x 3/4"
39	04001-20	Bolt, Hex Head 3/8-16 x 1-1/2"
40	04117-05	Nut, 7/16-14 Flange Elastic Stop
41	04117-04	Nut, 1/2-13 Flange Elastic Stop
42	462921	Main Frame Assembly w/decals (INCL. 24)
43	485663	Rubber Isolator
44	426931	Footplate
45	04020-12	Nut, Jam 3/8-16
46	484195	Cap, Grease
47	04021-20	Nut, Elastic Stop 1.0"-14
48	48668	Bearing Set
49	482028-01	Plug, 1/4-28
50	481025	Seal, 2.0" OD x 1.625" ID
51	453007	Yoke, Front Caster Wheel (black)
52	04021-07	Nut, Hex Elastic Stop 1/2-13
53	04001-167	Bolt, Hex Head 1/2-13 x 9-1/2"
54	43584	Spacer, Caster Wheel
55	43583	Sleeve
56	9278	Caster Wheel Assembly
57	04001-28	Bolt, Hex Head 7/16-14 x 1-1/4"
	04001-58	Bolt, Hex Head 7/16-14 x 1-1/2"
58	452284	Caster Support Weldment (48"/52")
	452727	Caster Support Weldment (61")
59	484617	Bushing, Thick Panel Snap
60	04003-31	Bolt, Carriage, 3/8-16 x 3/4"
61	04021-08	Nut, Lock, 1/4-20
62	04030-04	Washer, Lock 3/8 Spring
63	486019	Bushing, Thick Panel Snap - 1"
64	463325	Control Plate w/decal, LH (black)
65	428824	Weight, Caster - Yamaha Models Only

STCII FOLDABLE ROLL-OVER PROTECTION SYSTEM

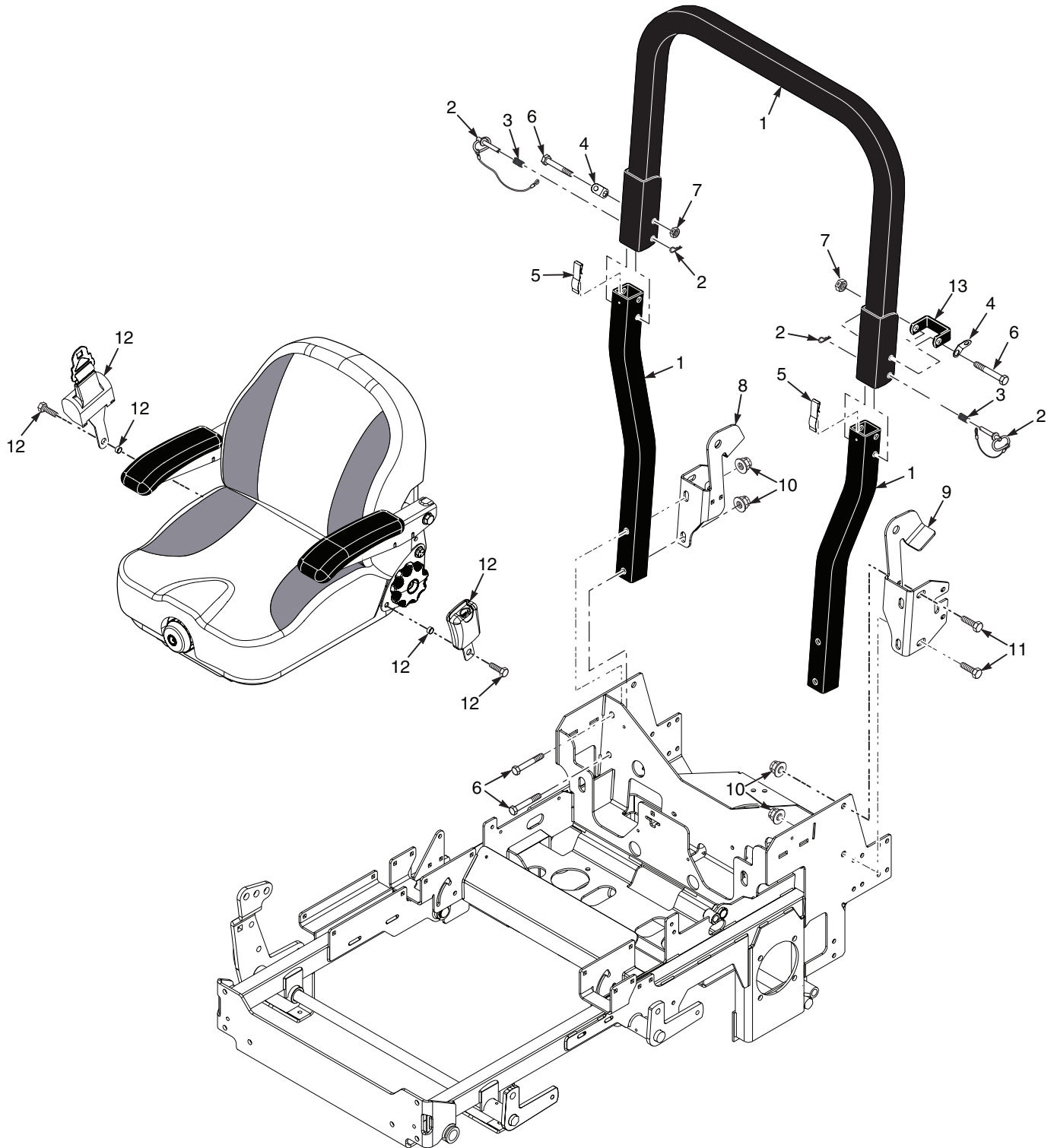

STCII FOLDABLE ROLL-OVER PROTECTION SYSTEM

Ref. No.	Part No.	Description
1	462414	ROPS Assembly, Foldable Without Stop
	462935	ROPS Assembly, Foldable With Stop
2	484168	Pin Assembly (incl. #3)
3	484170	Spring, ROPS
4	484169	Clip, ROPS
5	484167	Spring, ROPS Anti-Rattle
6	04001-90	Bolt, Hex Head 1/2-13 x 3-1/4"
7	04021-19	Nut, Center Lock 1/2-13
8	427029	ROPS Mount, RH, 22FX / 26FT-EFI / 25CV-EFI
	428575	ROPS Mount, RH, 27FX / 28BV-EFI / 32BV
9	427028	ROPS Mount, LH, 22FX / 26FT-EFI / 25CV-EFI
	428574	ROPS Mount, LH, 27FX / 28BV-EFI / 32BV
10	04117-04	Nut, 1/2-13 Flange Elastic Stop
11	04001-70	Bolt, Hex Head 1/2-13 x 1-1/4"
12	484717	Seat Belt Kit (Suspension Seat)
	484527	Seat Belt Kit (Soft Ride Seat)
13	427355	Stop, ROPS, 26FT / 32BV

STCII SUSPENSION SEAT

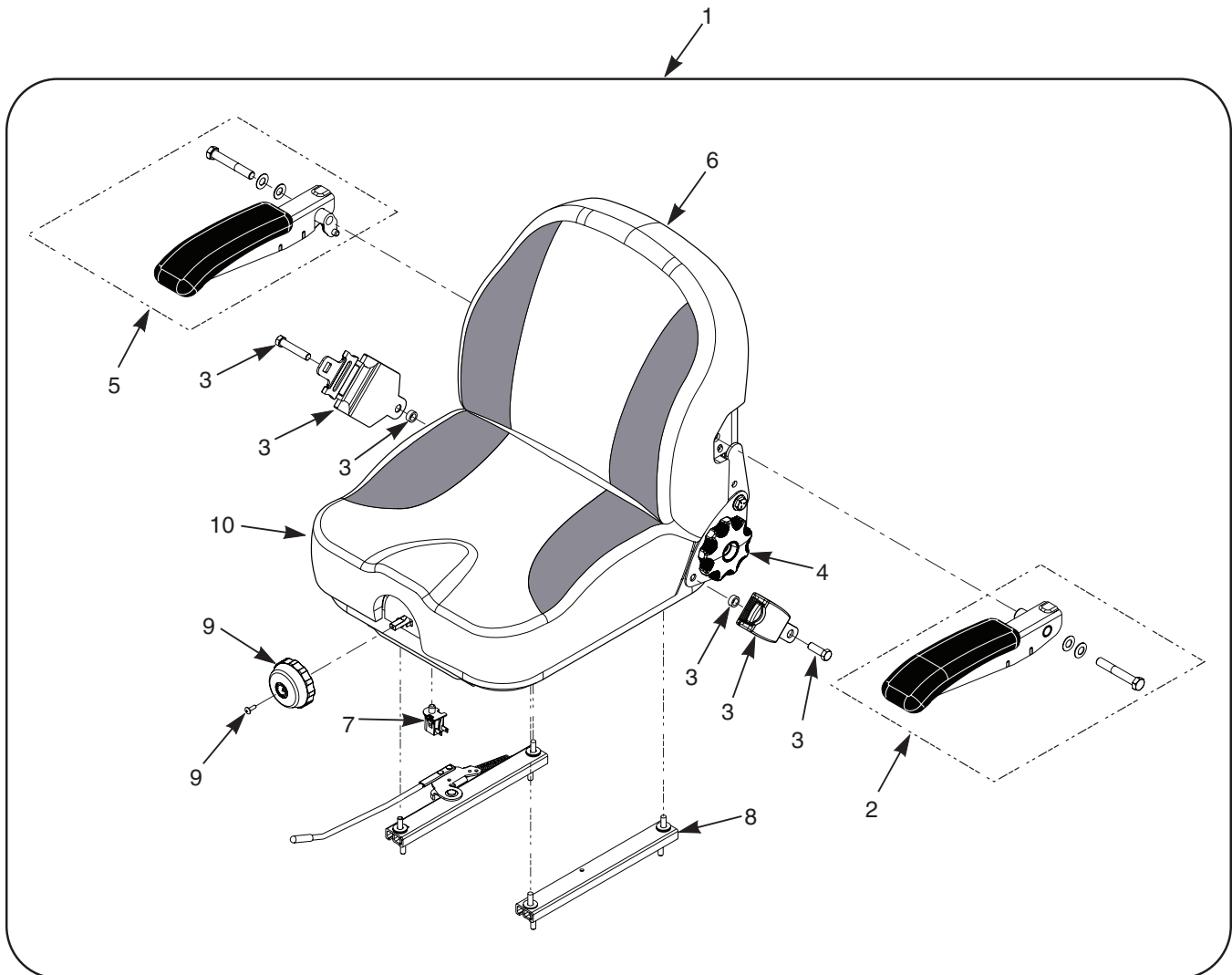

STCII SUSPENSION SEAT

Ref. No.	Part No.	Description
1	486591	Suspension Seat Assembly w/seat belt
2	484709	Armrest Kit, LH
3	484717	Seat Belt Kit
4	485652	Recliner Knob Kit
5	484710	Armrest Kit, RH
6	486596	Cover, Back Cushion
7	481638	Seat Switch
8	485594	Track Kit, (Includes Handle Kit p/n 485717)
9	484714	Suspension Knob Kit
10	486597	Cover, Seat Cushion
*	484719	Bellows (Track Cover)

* = Item Not Shown

DRIVE SYSTEM COMPONENTS

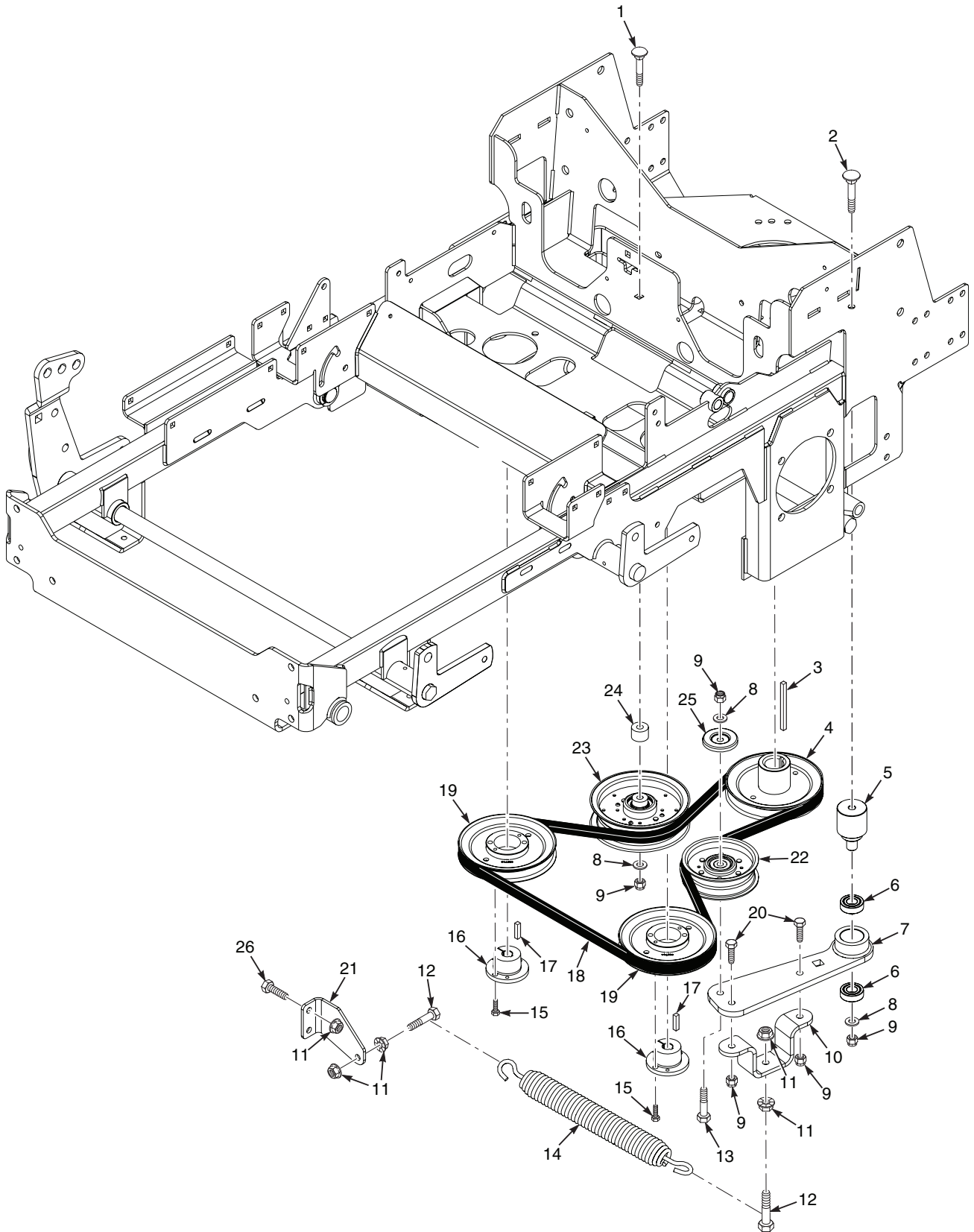

DRIVE SYSTEM COMPONENTS

Ref. No.	Part No.	Description
1	04003-47	Bolt, Carriage 3/8-16 x 3-1/4"
2	04003-26	Bolt, Carriage 3/8-16 x 4"
3	04063-28	Key, 1/4 x 1/4 x 3-1/2"
4	485589	Pulley, 5.75" Dia. - 1.125 Bore
5	431025	Pivot, Idler Arm
6	48224	Bearing
7	462860	Idler Arm Assembly (incl. #6)
8	04043-04	Flatwasher, 3/8-.391 x .938 x .105 HD
9	04021-09	Nut, Elastic Stop 3/8-16
10	425386	Mounting Bracket, Idler
11	04019-04	Nut, Serrated Flange 3/8-16
12	04001-136	Bolt, Hex Head 3/8-16 x 1-1/2" Grade 8
13	04001-46	Bolt, Hex Head 3/8-16 x 2-1/4"
14	484202	Spring, Pump Drive
15	04001-172	Bolt, Hex Head 1/4-20 x 1"
16	482085	Hub, Tapered, 15mm Bore
17	04063-14	Key, 5 x 5 x 25mm
18	485649	Belt, Pump Drive
19	482744	Pulley, 5.75" OD Taper Bore
20	04001-32	Bolt, Hex Head 3/8-16 x 1-1/4"
21	427016	Bracket, Spring Anchor
22	484128	Pulley, 4" Dia. Idler
23	483215	Pulley, 5" Dia. Idler
24	43286	Spacer
25	424367	Dust Shield
26	04003-23	Bolt, Carriage 3/8-16 x 1"

ENGINE & ATTACHING PARTS

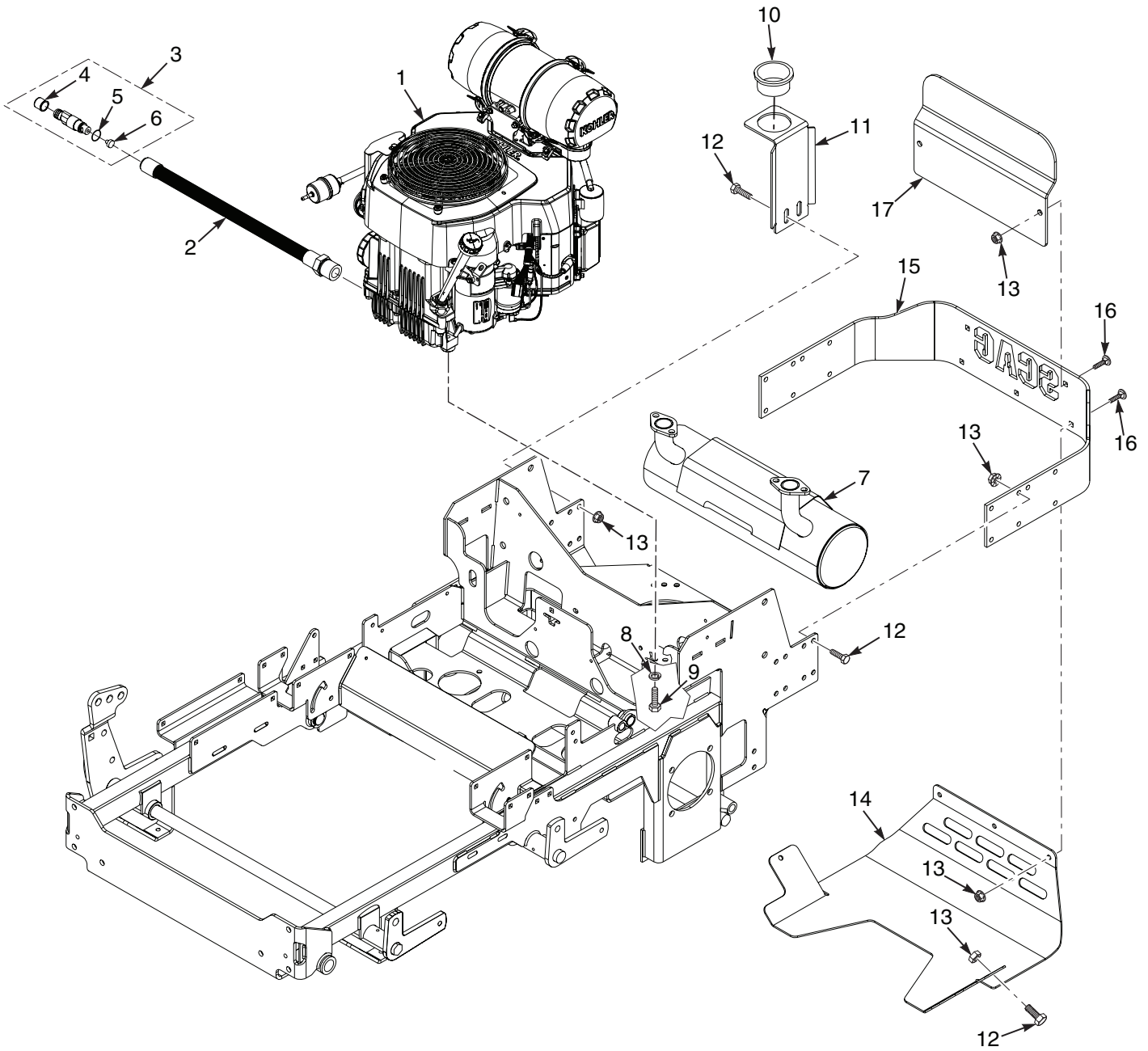

ENGINE & ATTACHING PARTS

Ref. No.	Part No.	Description
1	*485020	Engine, Kawasaki 22FX
	*485021	Engine, Kawasaki 23FX
	*487059	Engine, Yamaha MX800V
	*487243	Engine, Kawasaki 24FT
	*486149	Engine, Kawasaki 26FT-EFI
	*487060	Engine, Yamaha MX825V
	*485032	Engine, Kawasaki 27FX
	*485728	Engine, Kohler 25CV-EFI
	*485978	Engine, Briggs and Stratton 28BV-EFI
	*487061	Engine, Yamaha MX775-EFI
	*487062	Engine, Yamaha MX800V-EFI
2	*486585	Engine, Briggs and Stratton 32BV
	484706	Hose, Oil Drain - Kohler CV-EFI (incl. #3, 4, 5, 6)
	484599	Hose, Oil Drain - Briggs and Stratton 32BV (incl. #3, 4, 5, 6)
	484581	Hose, Oil Drain - Kawasaki FX, 24FT & FT-EFI (incl. #3, 4, 5, 6)
3	487107	Hose, Oil Drain - Yamaha MX & MX-EFI (incl. #3, 4, 5, 6)
	484583	Valve Assembly, Oil Drain
4	484585	Cap
5	48603-12	O-Ring
6	484586	Seal
7	485705	Muffler, Kawasaki 22 & 23FX, 24FT & FT-EFI
	486949	Muffler, Kawasaki 27FX
	484650	Muffler, Kohler 25CV-EFI
	486941	Muffler, Briggs and Stratton 28BV-EFI
	486579	Muffler, Briggs and Stratton 32BV
	*	Muffler, Yamaha
8	*	Muffler, Yamaha-EFI
	04030-04	Lockwasher, 3/8" Spring, Kawasaki FX / FT & FT-EFI / B&S 32BV / Yamaha MX
9	04001-32	Bolt, Hex Head 3/8-16 x 1-1/4", Kawasaki FX / FT & FT-EFI / Yamaha MX
	04011-07	Bolt, Hex Head 3/8-16 x 1-1/4" Self Tap, Kohler CV-EFI / B&S 28BV-EFI
	04001-20	Bolt, Hex Head 3/8-16 x 1-1/2" B&S 32BV
	04134-03	Nut, Top Lock w/ Flange, 3/8-16
10	484617	Bushing, Thick Panel Snap
11	426040	Bracket, Oil Drain Hose
12	04001-19	Bolt, Hex Head 3/8-16 x 1"
13	04019-04	Nut, Serrated Flange 3/8-16
14	427032	Plate, Skid
15	425725	Bumper, Rear
16	04003-23	Bolt, Carriage 3/8-16 x 1"
17	425926	Guard, Engine
**	04002-06	Bolt, Hex Head M8 - 1.25 x 16 (Engine Ground) FX / FT-EFI
**	04031-03	Lockwasher, 5/16 Ext Tooth (Engine Ground) FX / FT-EFI
**	04017-05	Bolt, Hex Head Serrated Flange 1/4-20 (Engine Ground) 25CV-EFI
**	04019-02	Nut, Serrated Flange 1/4-20 (Engine Ground) 25CV-EFI
**	04011-14	Screw, 1/4-20 x 3/4" Taptite (Engine Ground) B&S 28BV-EFI
**	04031-03	Lockwasher, 5/16 Ext Tooth (Engine Ground) B&S 28BV-EFI & 32BV
**	04001-08	Bolt, Hex Head 5/16-18 x 3/4" (Engine Ground) Yamaha MX
**	04031-03	Lockwasher, 5/16 Ext Tooth (Engine Ground) Yamaha MX

* = Not available through Scag.

** = Not Shown

STEERING COMPONENTS

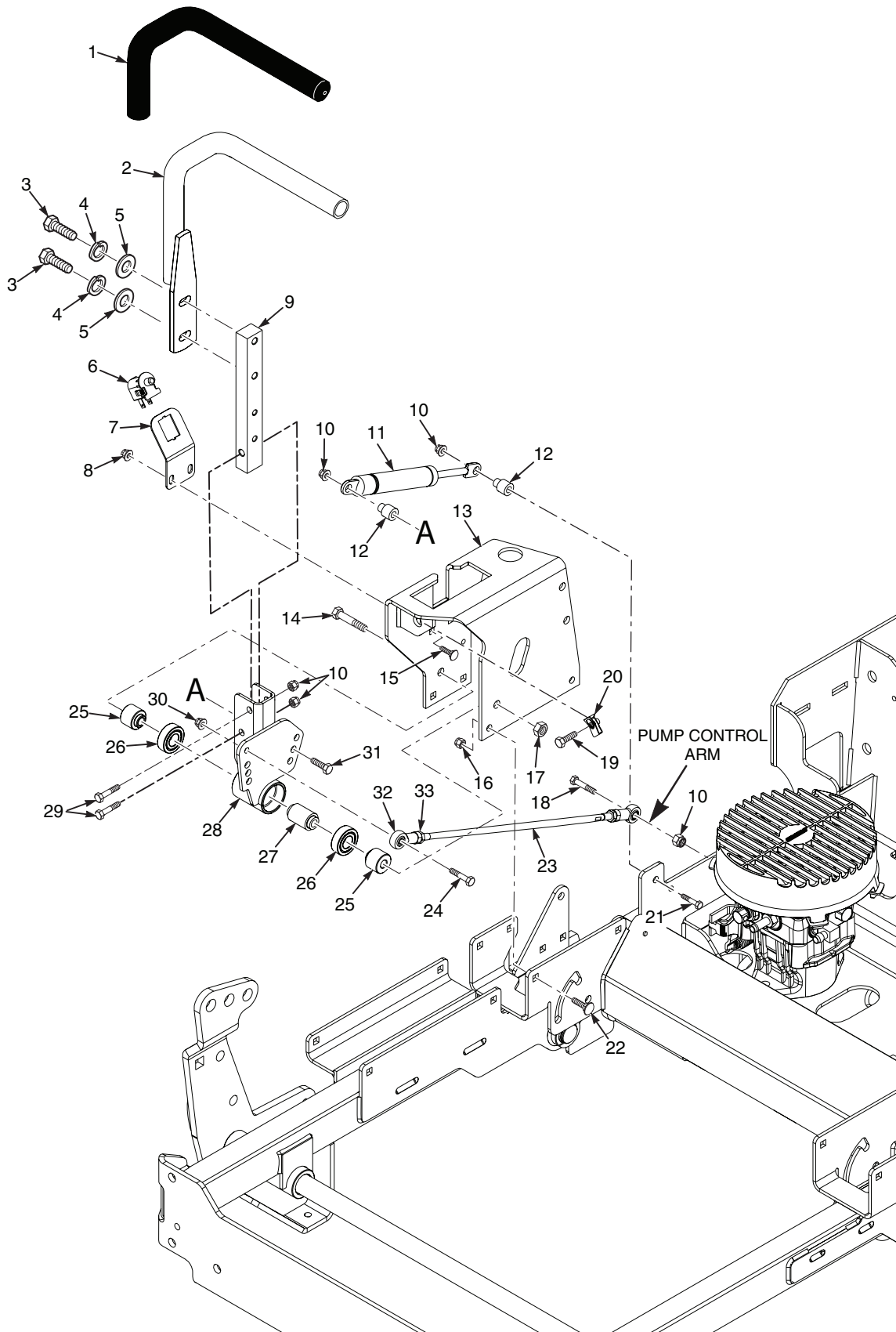

STEERING COMPONENTS

Ref. No.	Part No.	Description
1	484376	Grip, Control Handle
2	462401	Handle Bar w/Grip
3	04001-32	Bolt, Hex Head 3/8-16 x 1-1/4"
4	04030-04	Lockwasher, 3/8" Spring
5	04041-07	Flatwasher, 3/8-.391 x .938 x .105
6	481638	Switch, N/O
7	425905	Bracket, Operator Presence Switch
8	04117-03	Nut, Flanged Elastic Stop 1/4-20
9	422372	Bar, Control Lever
10	04021-10	Nut, Elastic Stop 5/16-18
11	484151	Gas Damper
12	43602	Spacer, Pump Dampener
13	463325	Control Plate w/decal, LH
	463326	Control Plate w/decal, RH
14	04001-152	Bolt, Hex Head 3/8-16 x 4-1/4"
15	04003-02	Bolt, Carriage 1/4-20 x 3/4"
16	04019-03	Nut, Serrated Flange 5/16-18
17	04021-05	Nut, Center Lock 3/8-16
18	04001-09	Bolt, Hex Head 5/16-18 x 1"
19	04107-03	Bolt, Hex Head 3/8-16 x 1-1/4" with Thread Lock Patch
20	04110-03	U-Nut, 3/8-16
21	04001-11	Bolt, Hex Head 5/16-18 x 1-1/2", RH
	04001-12	Bolt, Hex Head 5/16-18 x 1-3/4", LH
22	04003-12	Bolt, Carriage 5/16-18 x 3/4"
23	485583	Linkage Assy, Steering (INCL. 32,33)
	484073	Rod End, 5/16-24 LH
	04020-31	Nut, 5/16-24 UNF Jam
24	04001-04	Bolt, Hex Head 1/4-20 x 1-1/2"
25	43607	Spacer, Controls
26	48224	Bearing
27	43600	Spacer, Bearing
28	453204	Pivot Weldment, Control Arm RH
	453203	Pivot Weldment, Control Arm LH
29	04001-12	Bolt, Hex Head 5/16-18 x 1-3/4"
30	04021-08	Nut, Elastic Stop 1/4-20
31	04001-11	Bolt, Hex Head 5/16-18 x 1-1/2"
32	485584	Rod End, 5/16-24 RH
33	04020-30	Nut, 5/16-24 UNF LH Jam

BRAKE COMPONENTS

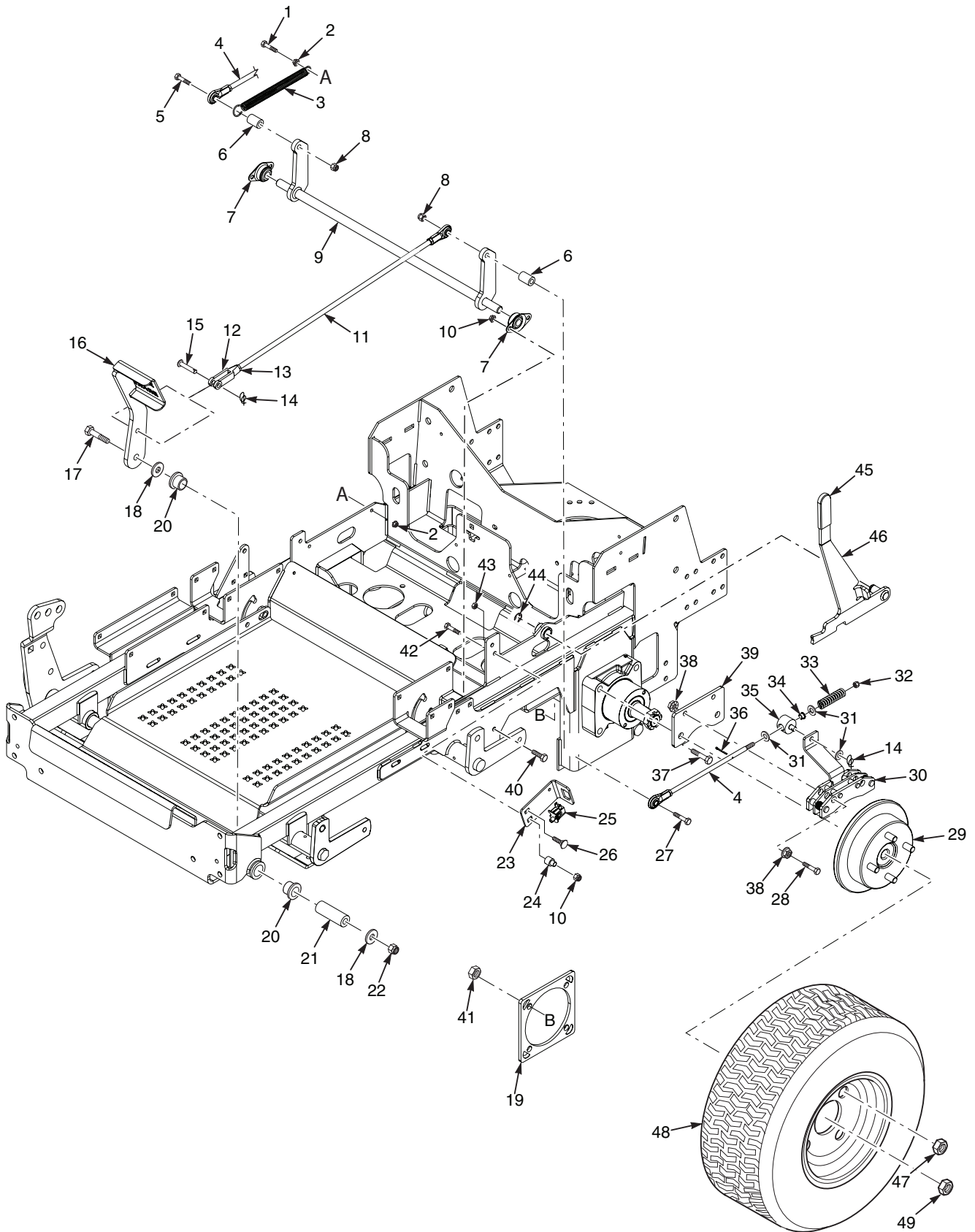

BRAKE COMPONENTS

Ref. No.	Part No.	Description
1	04001-59	Bolt, Hex Head 1/4-20 x 1-1/4"
2	04019-02	Nut, Serrated Flange 1/4-20
3	485831	Spring, Brake Return
4	462465	Brake Link Assembly (incl. #31, 32, 33, 34, 35, 36)
5	04001-54	Bolt, Hex Head 3/8-16 x 3"
6	43805	Spacer
7	48796	Bearing, Self Align - 5/8" I.D.
8	04117-02	Nut, Flanged Elastic Stop 3/8-16
9	452342	Brake Bellcrank Weldment
10	04021-10	Nut, Elastic Stop 5/16-18
11	485740	Brake Rod Assembly (INCL. #12,13)
	48544	Rod End, 3/8-24 LH
	04020-26	Nut, 3/8-24 UNF LH Jam
12	48343-04	Clevis
13	04020-25	Nut, 3/8-24 UNF Jam
14	04069-01	Pin, Rue Cotter - 3/8" Dia.
15	04064-02	Clevis Pin, 3/8 x 1.06"
16	452327	Brake Pedal Weldment
17	04001-194	Bolt, Hex Head 1/2-13 x 4-1/4"
18	04040-13	Flatwasher, 1/2-.562 x 1.375 x .109
19	423279	Plate, Motor Backing
20	483453-03	Bearing
21	43872	Sleeve, Brake Pivot
22	04021-07	Nut, Elastic Stop 1/2-13
23	426992	Switch Mounting Bracket, Brake
24	43602	Spacer
25	481638	Switch
26	04003-02	Bolt, Carriage 1/4-20 x 3/4"
27	04001-54	Bolt, Hex Head 3/8-16 x 3"

Ref. No.	Part No.	Description
28	04001-87	Bolt, 1/2-13 x 4"
29	462808	Brake Hub
30	485595	Brake Caliper
31	04040-05	Flatwasher, 3/8-.406 x .812 x .065
32	04021-18	Nut, Elastic Stop 3/8-24
33	484535	Spring, Brake
34	483453-23	Bearing
35	462452	Swivel Assembly, Brake
36	04061-02	Cotter Pin, 3/32 x 3/4"
37	04001-190	Bolt, Hex Head 1/2-13 x 2-3/4"
38	04019-06	Nut, 1/2-13 Serrated Flange
39	428482	Mounting Bracket, Brake
40	04001-08	Bolt, Hex Head 5/16-18 x 3/4"
41	04021-19	Nut, Center Lock 1/2-13
42	04001-12	Bolt, Hex Head 5/16-18 x 1-3/4"
43	04021-08	Nut, Elastic Stop 1/4-20
44	04050-01	Retaining Ring, .625 Ext "E"
45	482102	Grip, Brake Lever
46	462820	Lever w/Grip, Parking Brake
47	04028-02	Wheel Nut, 1/2-20
48	485586	Wheel Assy 24 x 9.5-12 (48" Deck)
	485587	Rim (48" Deck)
	484105	Wheel Assy 24 x 9.5-12 (52" Deck))
	481659	Rim (52" Deck)
	484104	Tire 24 x 9.5-12 (48" & 52" Deck)
	481850	Wheel Assy 24 x 12-12 (61" Deck)
	481851	Rim (61" Deck)
	481852	Tire 24 x 12-12 (61" Deck)
49	48680	Nut, Castle 1"- 20 UNEF
*	04061-06	Pin, Cotter 9/64 x 1-1/2", Wheel Hub

* = Not Shown

HYDRAULIC SYSTEM

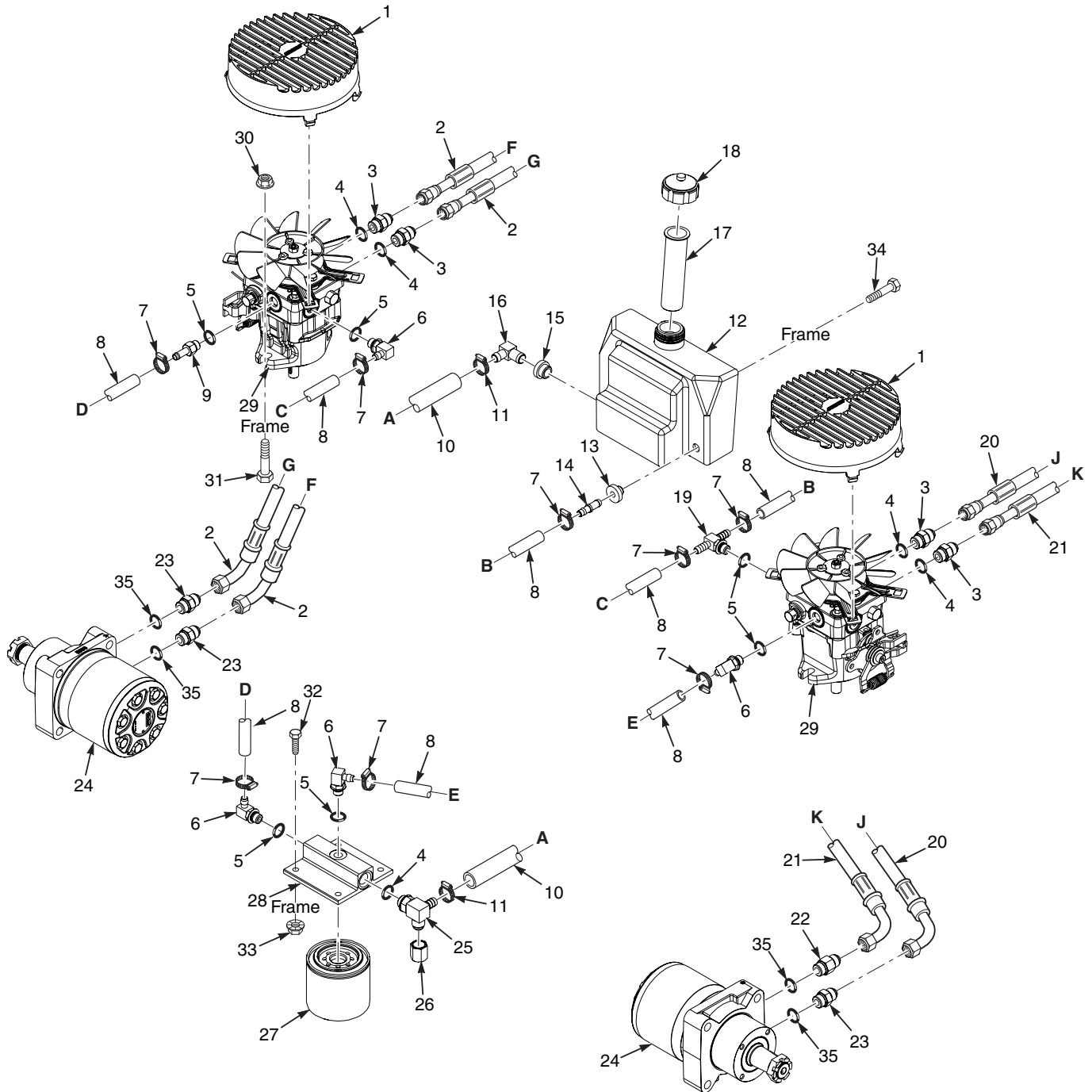

HYDRAULIC SYSTEM

Ref. No.	Part No.	Description
1	485564	Fan Cover, Pump
2	484452	Hose Assembly
3	48572-04	Fitting, 1/2" JIC x 1/2" O-Ring
4	48603-02	O-Ring, 3/4"
5	48603-06	O-Ring, 7/16"
6	482266-01	Elbow, 90 Degree 9/16" O-Ring x 3/8" Hose
7	48136-13	Hose Clamp, .69" Dia.
8	48811	Hose, 3/8" Pushlock (order by inch)
9	482800-02	Fitting, 9/16" O-Ring x 3/8" Hose
10	48351	Hose, 1/2" Pushlock (order by inch)
11	48136-05	Hose Clamp, .87" Dia.
12	462801	Hydraulic Tank Assy (incl. #13, 14, 15, 16, 17, 18)
13	482571	Bushing
14	485590	Fitting, Straight
15	482573	Bushing
16	482574	Fitting
17	481507	Insert, Filler Neck
18	481164	Cap, Hydraulic Tank
19	482277	Tee Fitting, O-Ring to Barb
20	485603	Hose Assembly
21	485602	Hose Assembly
22	48572-10	Fitting, 1/2" JIC x 5/8" O-Ring (LH Wheel Motor - Upper Port Only)
23	48572-02	Fitting, 1/2" JIC x 5/8" O-Ring
24	482639	Wheel Motor, Parker
25	482483	Tee, 3/4" O-Ring x JIC x 1/2" Hose
26	48571-02	Cap
27	48462-01	Oil Filter
28	482417	Oil Filter Base
29	485573	Pump, LH (PK-3KCC-GA1F-XXXX)
	485574	Pump, RH (PK-3HCC-GA1F-XXXX)
30	04117-02	Nut, Flange Elastic Stop 3/8-16
31	04001-20	Bolt, Hex Head, 3/8-16 x 1-1/2"
32	04001-08	Bolt, Hex Head, 3/8-16 x 3/4"
33	04019-03	Nut, Serrated Flange 5/16-18
34	04017-15	Bolt, Hex Head, Serrated Flange 5/16-18 x 1/2"
35	48603-04	O-Ring, 5/8"

STCII FUEL SYSTEM

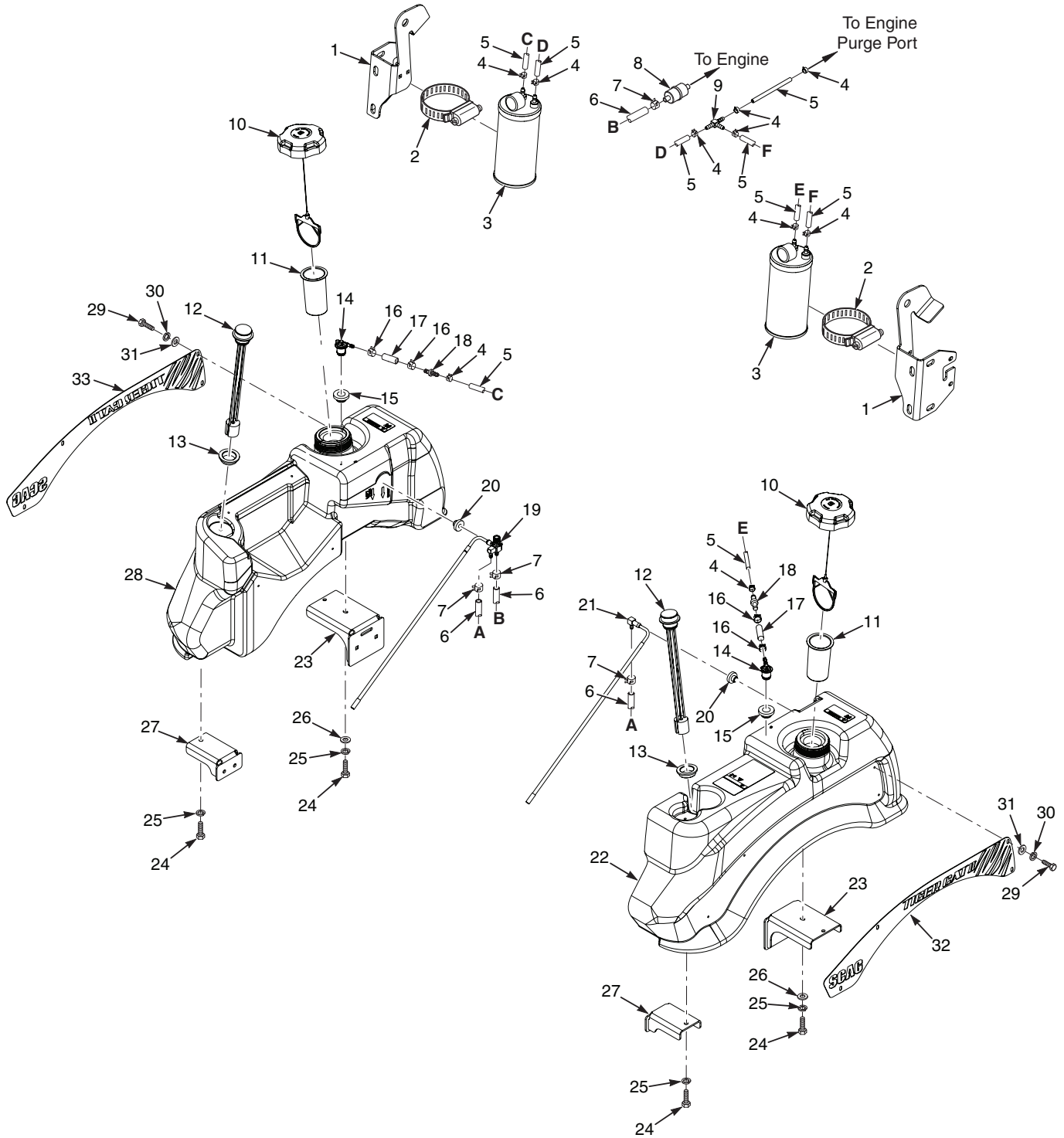

STCII FUEL SYSTEM

Ref. No.	Part No.	Description
1	427028	ROPS Mount, LH, 22FX / 26FT-EFI / 25CV-EFI
	428574	ROPS Mount, LH, 27FX / 28BV-EFI / 32BV
	427029	ROPS Mount, RH, 22FX / 26FT-EFI / 25CV-EFI
	428575	ROPS Mount, RH, 27FX / 28BV-EFI / 32BV
2	48136-17	Clamp
3	484287	Carbon Canister, 400cc
	484366	Dust Filter, Carbon Canister
4	48059-05	Clamp, Vapor Recovery Hose
5	484345	Hose, 3/16" (order by inch)
6	483617	Hose, Non-Perm Fuel 1/4" I.D.
7	48059-01	Clamp, Fuel Hose 1/4" I.D.
8	**	Fuel Filter
9	48935-02	Tee, 3/16 x 3/16 x 3/16 Union, Hose Barb
10	484286	Fuel Cap, Tethered
	484297	Fuel Cap, Tethered (California Only)
11	484279-01	Tube, Fuel Tank Insert - 4"
12	484323	Fuel Gauge Assembly (incl. #13)
13	484242	Seal, Fuel Gauge
14	484333	Remote Vent
15	484285	Grommet, Viton
16	48059-02	Clamp, Fuel Hose 7/32
17	484347	Hose, Vapor Recovery (order by inch)
18	484343-01	Mender, 1/4 x 3/16
19	485637	Fuel Tube Assembly, Includes Valve
20	482571	Bushing, .56 Viton
21	484552	Fuel Tube Assembly, LH
22	463297	Fuel Tank Assembly, LH (incl. # 12, 14, 15, 20, 21, 29, 30, 31, 32)
23	427063	Mounting Bracket, Fuel Tank Rear
24	04001-08	Bolt, Hex Head 5/16-18 x 3/4"
25	04030-03	Lockwasher, 5/16" Spring
26	04040-15	Flatwasher, 5/16-.375 x .875 x .083
27	425862	Mounting Bracket, Fuel Tank Front
28	463299	Fuel Tank Assembly, RH (incl. #12, 14, 15, 19, 20, 29, 30, 31, 33)
29	04001-44	Bolt, Hex Head 1/4-20 x 1/2"
30	04030-02	Lockwasher, 1/4" Spring
31	04041-22	Flatwasher, 1/4-.256 x .490 x .0598
32	428700	Logo, Scag Tiger Cat II (RH)
33	428699	Logo, Scag Tiger Cat II (LH)

** = Available through engine manufacturer only.

ELECTRICAL SYSTEM

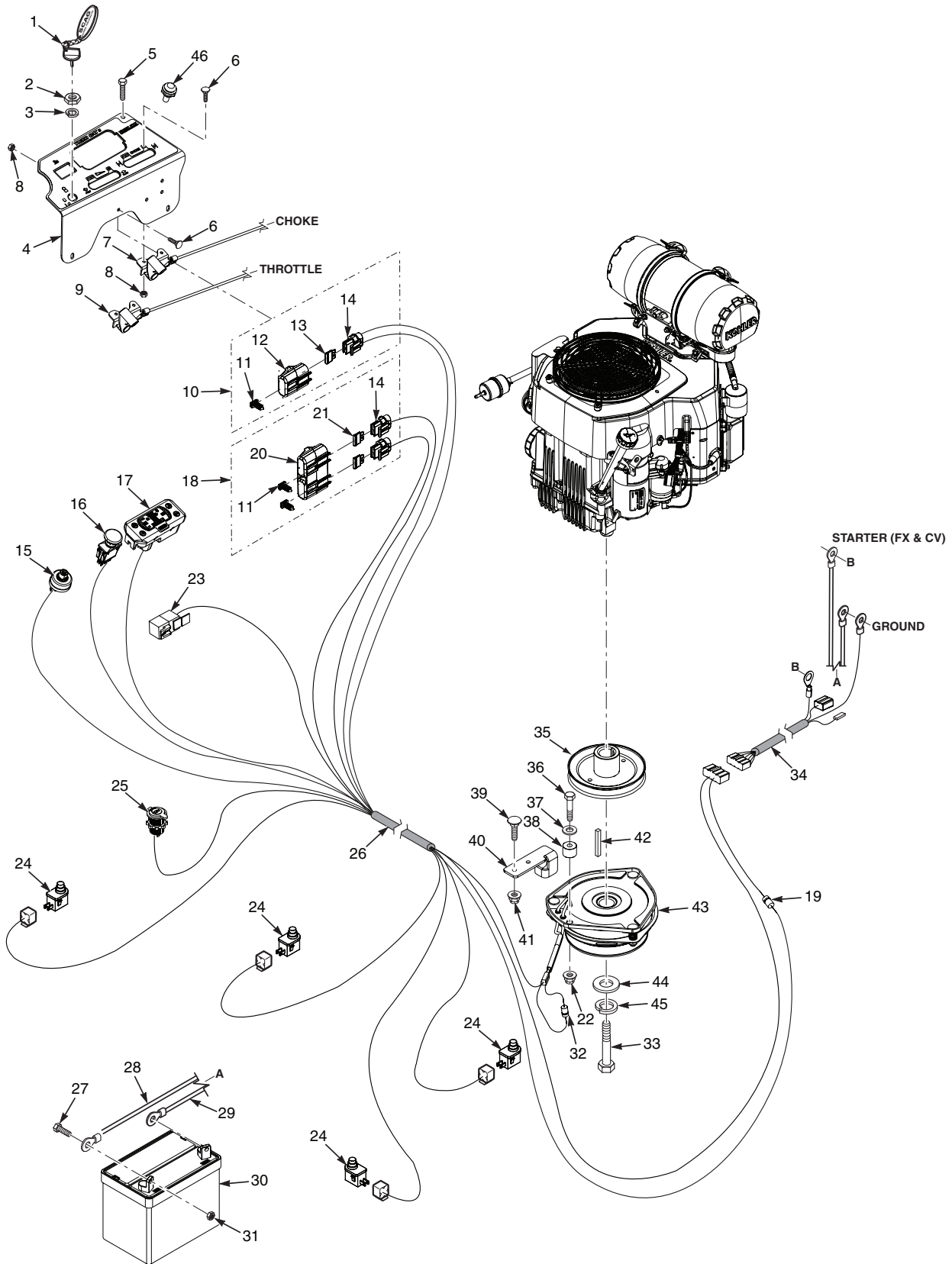

ELECTRICAL SYSTEM

Ref. No.	Part No.	Description
1	462069	Key, Ignition
2	48017-04	Nut, Hex 5/8-32
3	48017-03	Lockwasher, 5/8" Internal
4	462862	Instrument Panel w/Decal
5	04017-04	Bolt, Hex Head Serrated Flange 1/4-20 x 1/2"
6	04003-43	Bolt, Carriage #10-24 x 1/2"
7	485628	Choke Control Cable (Kawasaki FX, Yamaha MX)
8	04021-26	Locknut, #10-24
9	485628	Throttle Control Cable
	486589	Throttle Control Cable (32BV & 28BV-EFI)
10	485739	Single Fuse Assy. (incl. #11, 12, 14)
11	482588	Clip, Wire
12	483643	Cover, Sealed Single
13	485674	Fuse, 5 Amp
14	483629	Fuse Holder
15	48798	Switch, Starter
16	485833	Switch, PTO
17	484721	Cluster Gauge
18	483642	Double Fuse Assy. (incl. #11, 14, 20, 21)
19	482253	Diode
20	483571	Cover, Sealed Double
21	48298	Fuse, 20 Amp
22	04021-10	Nut, Elastic Stop 5/16-18
23	483013	Relay
24	481638	Switch
25	485568	Power Plug
26	486013	Wire Harness - FX / Yamaha MX
	486125	Wire Harness - 28BV-EFI & 32BV
27	04001-44	Bolt, Hex Head 1/4-20 x 1/2"
28	48029-28	Battery Cable, 25" Red
29	48029-11	Battery Cable, 27" Black
30	*	Battery, 350 CCA
31	04020-02	Nut, 1/4-20 UNC
32	483958	Diode, 600V - 6A
33	04102-03	Bolt, Hex Head 7/16-20 x 2-1/4" w/Patch, B&S 28BV-EFI & 32BV
	04102-05	Bolt, Hex Head 7/16-20 x 2-3/4" w/Patch, Kawasaki FX / Yamaha MX
34	485678	Wire Harness Adapter, Kawasaki FX
	486946	Wire Harness Adapter 28BV-EFI
	487063	Wire Harness Adapter Yamaha MX
	486139	Wire Harness Adapter 32BV
35	485589	Pulley, 5.75" Dia. - 1.125 Bore
36	04001-17	Bolt, Hex Head 5/16-18 x 2"
37	04040-15	Flatwasher, 5/16-.375 x .875 x .083
38	431041	Bushing, UHMW
39	04003-12	Bolt, Carriage 5/16-18 x 3/4"
40	427330	Anti-Rotation Bracket
41	04117-01	Nut, Flange Elastic Stop 5/16-18
42	04063-28	Key, 1/4 x 1/4 x 3-1/2"
43	462339	Clutch, GT3.5 - 1.125 Bore
44	04041-28	Flatwasher, 7/16-.469 x 1.75 x .25
45	04030-05	Lockwasher, 7/16" Spring
46	481182	Indicator Light
**	48126	Rubber Boot, Battery Cable

* = Not available through Scag.

** = Not Shown

ELECTRICAL SYSTEM - KAWASAKI 26FT-EFI

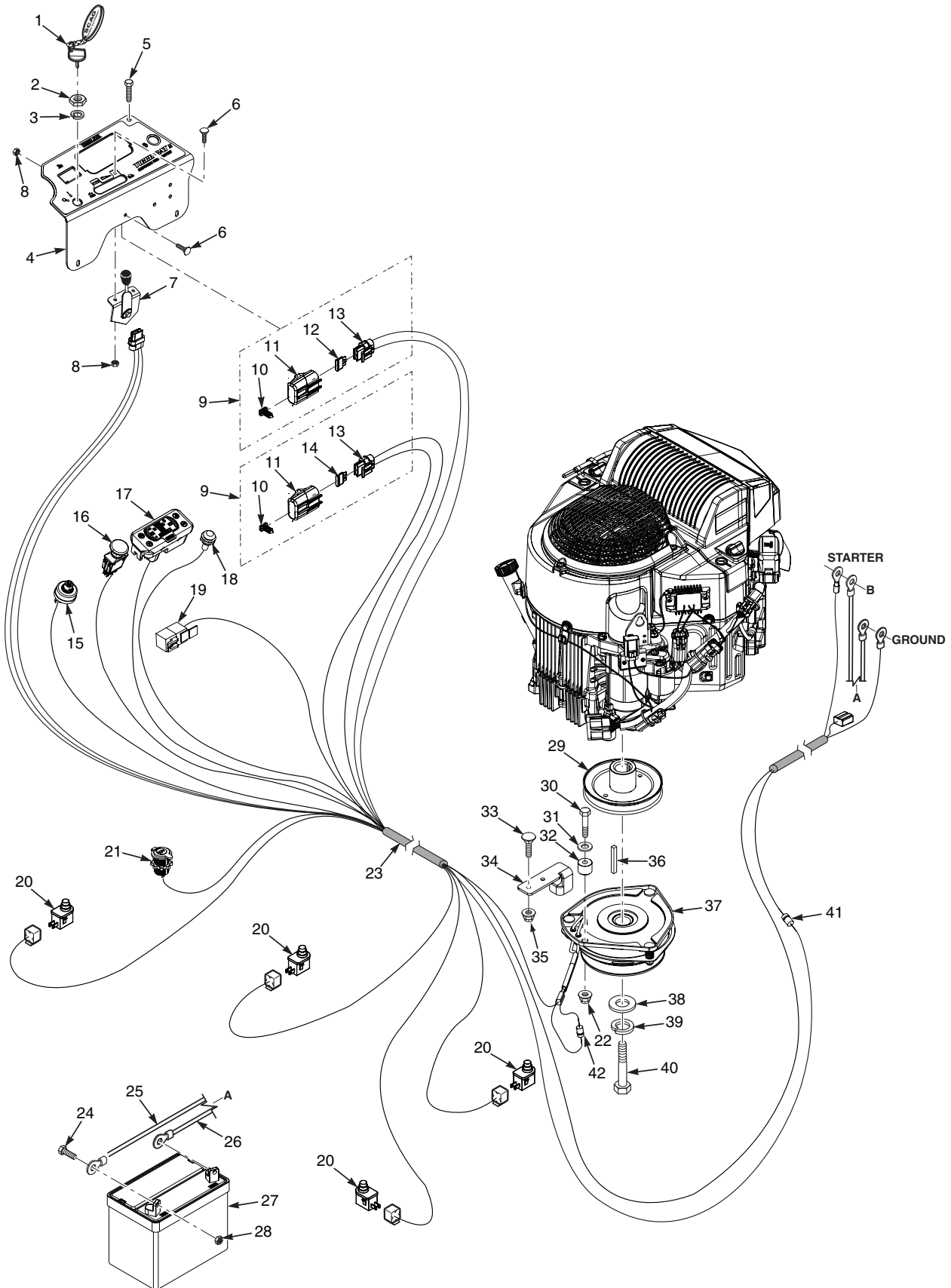

Section 8

ELECTRICAL SYSTEM - KAWASAKI 26FT-EFI

Ref. No.	Part No.	Description
1	462069	Key, Ignition
2	48017-04	Nut, Hex 5/8-32
3	48017-03	Lockwasher, 5/8" Internal
4	463050	Instrument Panel w/Decal
5	04017-04	Bolt, Hex Head Serrated Flange 1/4-20 x 1/2"
6	04003-43	Bolt, Carriage #10-24 x 1/2"
7	485464	Control, E-Gov Throttle
	483533	Knob, Throttle Control
8	04021-26	Locknut, #10-24
9	485739	Single Fuse Assy. (incl. #10, 11, 13)
10	482588	Clip, Wire
11	483643	Cover, Sealed Single
12	485674	Fuse, 5 Amp
13	483629	Fuse Holder
14	48298	Fuse, 20 Amp
15	48798	Switch, Starter
16	485833	Switch, PTO
17	484721	Cluster Gauge
18	481182	Indicator Light
19	483013	Relay
20	481638	Switch
21	485568	Power Plug
22	04021-10	Nut, Elastic Stop 5/16-18
23	486124	Wire Harness, STCII-26FT-EFI
24	04001-44	Bolt, Hex Head 1/4-20 x 1/2"
25	48029-28	Battery Cable, 25" Red
26	48029-11	Battery Cable, 27" Black
27	*	Battery, 350 CCA
28	04020-02	Nut, 1/4-20 UNC
29	485589	Pulley, 5.75" Dia. - 1.125 Bore
30	04001-17	Bolt, Hex Head 5/16-18 x 2"
31	04040-15	Flatwasher, 5/16-.375 x .875 x .083
32	431041	Bushing, UHMW
33	04003-12	Bolt, Carriage 5/16-18 x 3/4"
34	427330	Anti-Rotation Bracket
35	04117-01	Nut, Flange Elastic Stop 5/16-18
36	04063-28	Key, 1/4 x 1/4 x 3-1/2"
37	462339	Clutch, GT3.5 - 1.125 Bore
38	04041-28	Flatwasher, 7/16-.469 x 1.75 x .25
39	04030-05	Lockwasher, 7/16" Spring
40	04102-05	Bolt, Hex Head 7/16-20 x 2-3/4" w/Patch
41	482253	Diode
42	483958	Diode, 600V - 6A
**	48126	Rubber Boot, Battery Cable

* = Not available through Scag.

** = Not Shown

ELECTRICAL SYSTEM - KOHLER EFI / YAMAHA EFI

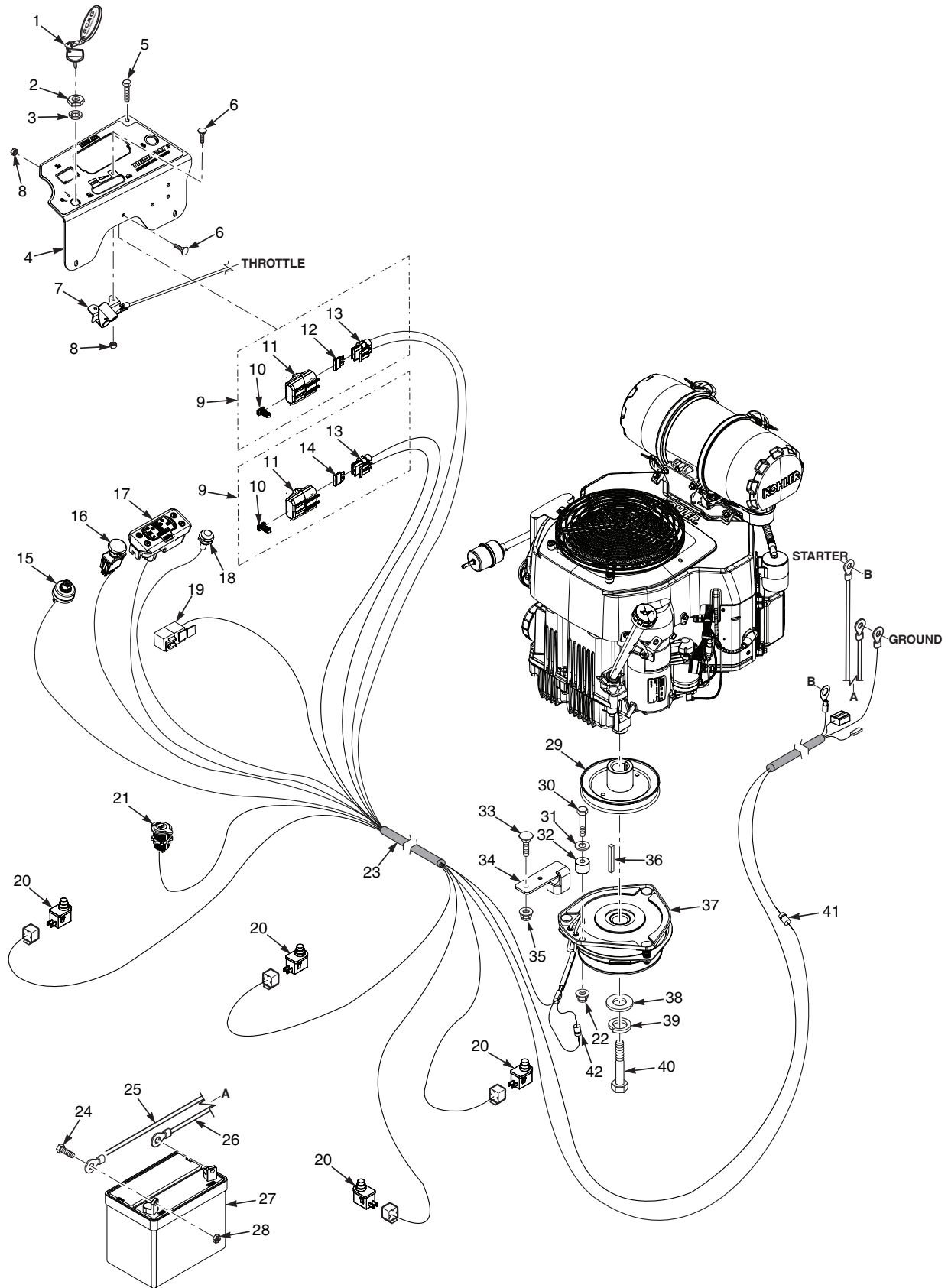

Section 8

ELECTRICAL SYSTEM - KOHLER EFI / YAMAHA EFI

Ref. No.	Part No.	Description
1	462069	Key, Ignition
2	48017-04	Nut, Hex 5/8-32
3	48017-03	Lockwasher, 5/8" Internal
4	462862	Instrument Panel w/Decal
5	04017-04	Bolt, Hex Head Serrated Flange 1/4-20 x 1/2"
6	04003-43	Bolt, Carriage #10-24 x 1/2"
7	485628	Throttle Control Cable
8	04021-26	Locknut, #10-24
9	485739	Single Fuse Assy. (incl. #10, 11, 13)
10	482588	Clip, Wire
11	483643	Cover, Sealed Single
12	485674	Fuse, 5 Amp
13	483629	Fuse Holder
14	48298	Fuse, 20 Amp
15	48798	Switch, Starter
16	485833	Switch, PTO
17	484721	Cluster Gauge
18	481182	Indicator Light
19	483013	Relay
20	481638	Switch
21	485568	Power Plug
22	04021-10	Nut, Elastic Stop 5/16-18
23	486125	Wire Harness, STCII-CV-EFI / YAMAHA-EFI
24	04001-44	Bolt, Hex Head 1/4-20 x 1/2"
25	48029-28	Battery Cable, 25" Red
26	48029-11	Battery Cable, 27" Black
27	*	Battery, 350 CCA
28	04020-02	Nut, 1/4-20 UNC
29	485589	Pulley, 5.75" Dia. - 1.125 Bore
30	04001-17	Bolt, Hex Head 5/16-18 x 2"
31	04040-15	Flatwasher, 5/16-.375 x .875 x .083
32	431041	Bushing, UHMW
33	04003-12	Bolt, Carriage 5/16-18 x 3/4"
34	427330	Anti-Rotation Bracket
35	04117-01	Nut, Flange Elastic Stop 5/16-18
36	04063-28	Key, 1/4 x 1/4 x 3-1/2"
37	462339	Clutch, GT3.5 - 1.125 Bore
38	04041-28	Flatwasher, 7/16-.469 x 1.75 x .25
39	04030-05	Lockwasher, 7/16" Spring
40	04102-03	Bolt, Hex Head 7/16-20 x 2-1/4" w/Patch
	04103-05	Bolt, Hex Head 7/16-20 x 2-3/4" w/Patch - Yamaha EFI
41	482253	Diode
42	483958	Diode, 600V - 6A
**	48126	Rubber Boot, Battery Cable

* = Not available through Scag.

** = Not Shown

STCII HYDRAULIC PUMP ASSEMBLY

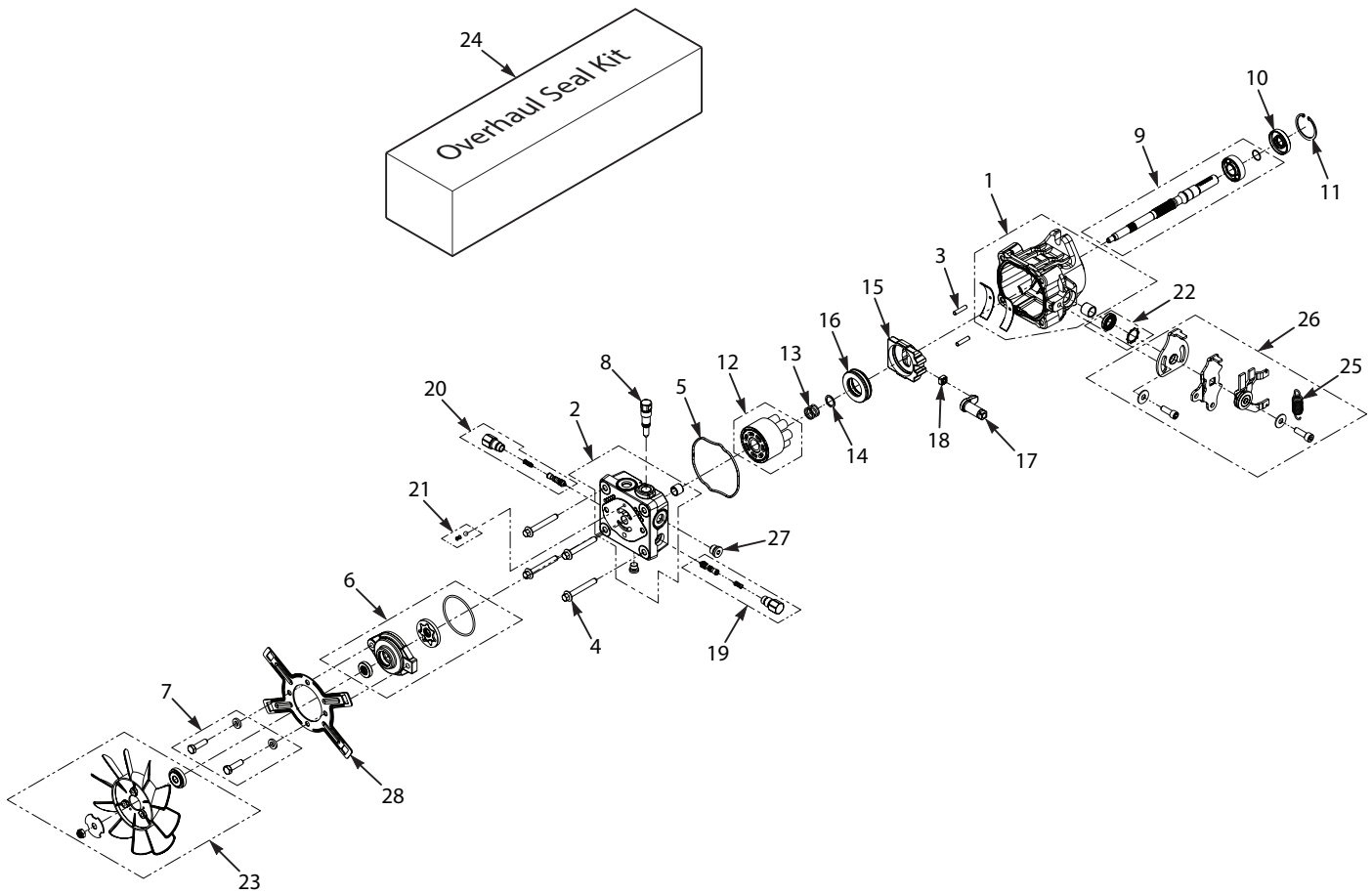

STCII HYDRAULIC PUMP ASSEMBLY

Ref. No.	Part No.	Description
1	HG 71717	Housing Kit
2	HG 72011	End Cap Kit
3	HG 50641	Straight Headless Pin
4	HG 50969	Hex Flange Bolt, M8-1.25 x 60mm
5	HG 54022	Housing O-Ring
6	HG 71247	Charge Pump Kit
7	HG 72254	Charge Pump Bolt Kit
8	HG 2513030	Bypass Valve Kit
9	HG 70620	Pumpshaft Kit
10	HG 51161	Lip Seal
11	HG 50329	Retaining Ring (Internal)
12	HG 71971	Cylinder Block Kit
13	HG 2003014	Block Spring
14	HG 2003017	Flat Washer
15	HG 2003087	Swash Plate
16	HG 53502	Thrust Bearing
17	HG 52866	Trunnion Arm
18	HG 2000015	Slot Guide
19	HG 70743	Shock Valve Kit (.031" Orifice)
20	HG 70743	Shock Valve Kit (.031" Orifice)
21	HG 70402	Charge Relief Kit
22	HG 2513043	Trunnion Seal with Retainer
23	HG 70811	Fan/Hub Kit
24	HG 70525	Overhaul Seal Kit
25	HG 52401	Spring, Extension
26	HG 71716	RTN Kit (Std Scissor, Std Spring)
27	HG 9005110-5600	Straight Thread Plug
28	HG 52355	Bracket

REPLACEMENT DECALS AND INFORMATION PLATES

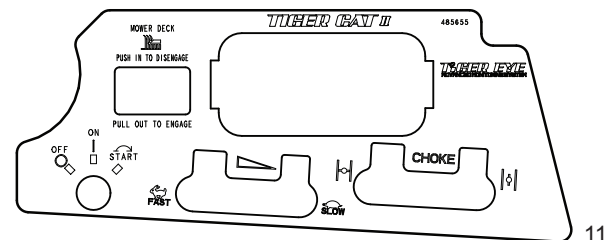
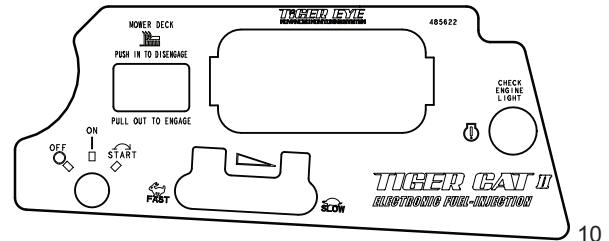
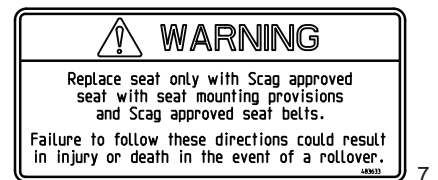
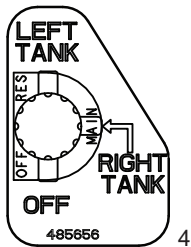
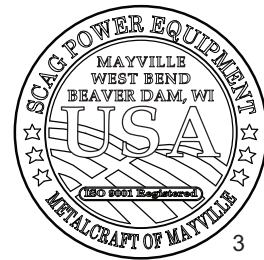

REPLACEMENT DECALS AND INFORMATION PLATES

Ref. No.	Part No.	Description
1	483407	Decal, Danger-Spinning Blades
2	483406	Decal, Warning-Rotating Blades
3	485403	Decal, Metalcraft - USA
4	485656	Decal, Fuel Valve Position
5	482100	Decal, Traction Control
6	483425	Decal, ROPS
7	483633	Decal, Seat Replacement
8	483402	Decal, Belt Cover
9	484453	Decal, Heavy Duty Commercial
10	485622	Decal, Instrument Panel - Kohler EFI
	485932	Decal, Instrument Panel - Kawasaki EFI
11	485655	Decal, Instrument Panel
12	484134	Decal, Deck Height - LH
13	484135	Decal, Deck Height - RH
14	485629	Decal, Tiger Cat II
15	483199	Decal, 48V
	483200	Decal, 52V
	483201	Decal, 61V
16	485654	Decal, Seat Support
17	485521	Decal, Belt Routing (48V & 52V)
	485522	Decal, Belt Routing (61V)
18	486285	Decal, STCII Replacement Parts
19	485551	Decal, Start/Drive
20	483405	Decal, Warning
21	486203	Decal, Scag
22	486202	Decal, Scag Tiger Cat II
**	462893	Spanish Decal Kit, (not shown)
**	01411	DVD Video, Tips for Safe Operation of Your Scag Zero-Turn Mower

IMPORTANT ADJUSTMENT PROCEDURES
 READ OPERATOR'S MANUAL FOR MORE DETAILS
 Check tire pressure - (Drive tires-12 psi)
 - (Caster tires-25 psi)

NEUTRAL ADJUSTMENT
 Loosen jam nuts
 Rotate turnbuckle
 With an operator in the seat, engine running, control lever in neutral and the parking brake disengaged - adjust control linkage. Loosen jam nuts. If wheel rotates forward, adjust turnbuckle CW. If wheel rotates rearward, adjust turnbuckle CCW. Adjust until drive wheel stops turning. Tighten jam nuts. Repeat procedure until proper Neutral Adjustment is obtained.

TRACKING ADJUSTMENT
 If the machine pulls to the right, adjust LH control linkage CW to slow left wheel. If the machine pulls to the left adjust RH control linkage CW to slow right wheel. Readjust neutral if necessary.

FREE WHEEL OPERATION
 To move machine without running the engine, rotate both dump valves located at the LH side of the jumps CW 1/2 turn to "freewheel" positions. Return dump valves to original position to operate the mower. Tighten to 7-10 ft-lbs.

HYDRAULIC FLUID LEVEL
 Check hydraulic fluid level while fluid is cool. Fluid level should be 2" below top of filler neck. Fill with SAE 20W50 motor oil only.

IMPORTANT
 Do not overfill. Room for hot fluid expansion must be allowed or resulting expansion may cause leaks in the system.

485654

16

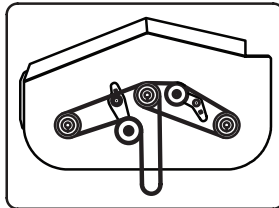

17

WARNING

DO NOT OPERATE WITHOUT DISCHARGE CHUTE, MULCHING KIT, OR ENTIRE GRASS CATCHER INSTALLED

483405

20

Replacement Parts Numbers TIGER CAT II

Always use original Scag replacement parts for top machine performance and to maintain factory warranty.

Blk, Pump Drive HP 4 821	486448	Standard Deck, Cutter HP1	482877
Blk, Pump Drive HP1	486448	Standard Deck, Cutter S21	482878
Blk, Cutter Deck-LH HP1	486334	Standard Deck, Cutter HP1	482878
Blk, Cutter Deck-RH HP1	482230	Spindle Dresser: MidRange 20" 222	
Blk, Cutter Deck-LH S21	486336	Excess Blade Frame HP	
Blk, Cutter Deck-RH S21	482240	Excess Blade Drive S22	
Blk, Cutter Deck-LH HP1	486336	Filter, Hydraulic 60 micron	48482-01
Blk, Cutter Deck-RH HP1	483857		

See your authorized Scag dealer for engine part numbers.

18

START/DRIVE PROCEDURE

- Engage parking brake
- Disengage mower deck drive
- Move control handles to neutral lock position
- Start engine
- Release parking brake
- Select forward or reverse with hydro control handles

WARNING

AVOID SERIOUS INJURY OR DEATH

- Read the Operator's Manual
- Solicite etiquetas en español a un distribuidor Scag
- Operate only on slopes you can back up and never on slopes greater than 15 degrees
- If machine stops going uphill, stop blades and back down slowly
- Avoid sudden turns
- Do not mow when children or others are around
- Never carry children even with blades off
- Look down and behind before and while backing
- Keep safety devices (guards, shields, switches, etc.) in place and working
- Remove objects that could be thrown by the blades
- Trained operators only

485551

19



21



22

STCII - KAWASAKI FX / YAMAHA MX ELECTRICAL SCHEMATIC

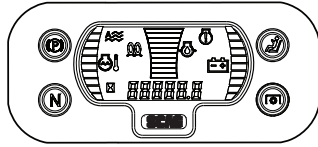

Position	Key Switch Legend
OFF	G + M + A
RUN	B + L + A
START	B + L + S

Position	PTO Switch Legend												
ON (UP)	<table border="1"> <tr><td>1</td><td>2</td><td>3</td><td>4</td><td>5</td><td>6</td></tr> <tr><td>7</td><td>8</td><td>9</td><td>10</td><td>11</td><td>12</td></tr> </table>	1	2	3	4	5	6	7	8	9	10	11	12
1	2	3	4	5	6								
7	8	9	10	11	12								
DOWN (OFF)	<table border="1"> <tr><td>1</td><td>2</td><td>3</td><td>4</td><td>5</td><td>6</td></tr> <tr><td>7</td><td>8</td><td>9</td><td>10</td><td>11</td><td>12</td></tr> </table>	1	2	3	4	5	6	7	8	9	10	11	12
1	2	3	4	5	6								
7	8	9	10	11	12								

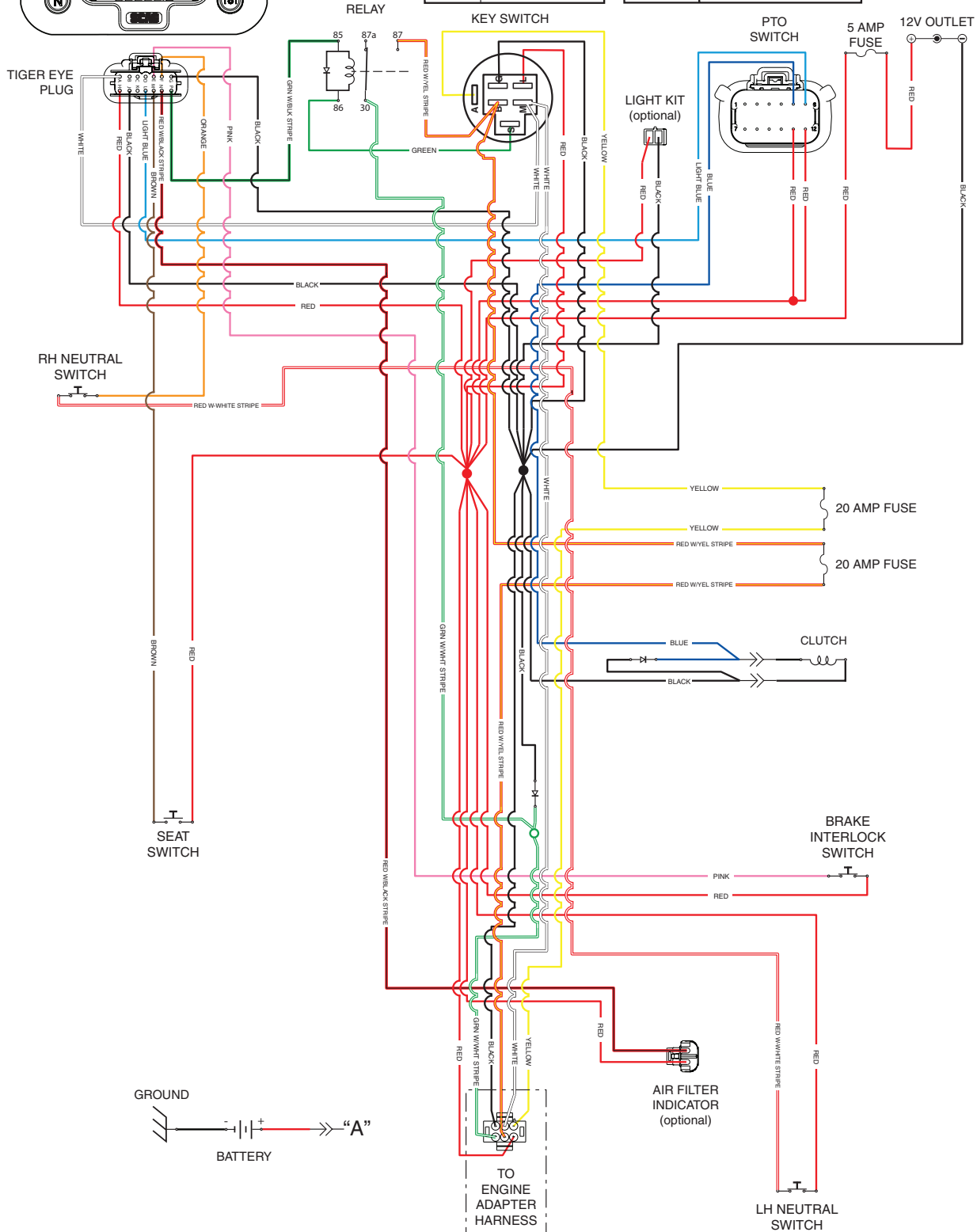

STCII KAWASAKI FX ENGINE ADAPTER ELECTRICAL SCHEMATIC P/N 485678

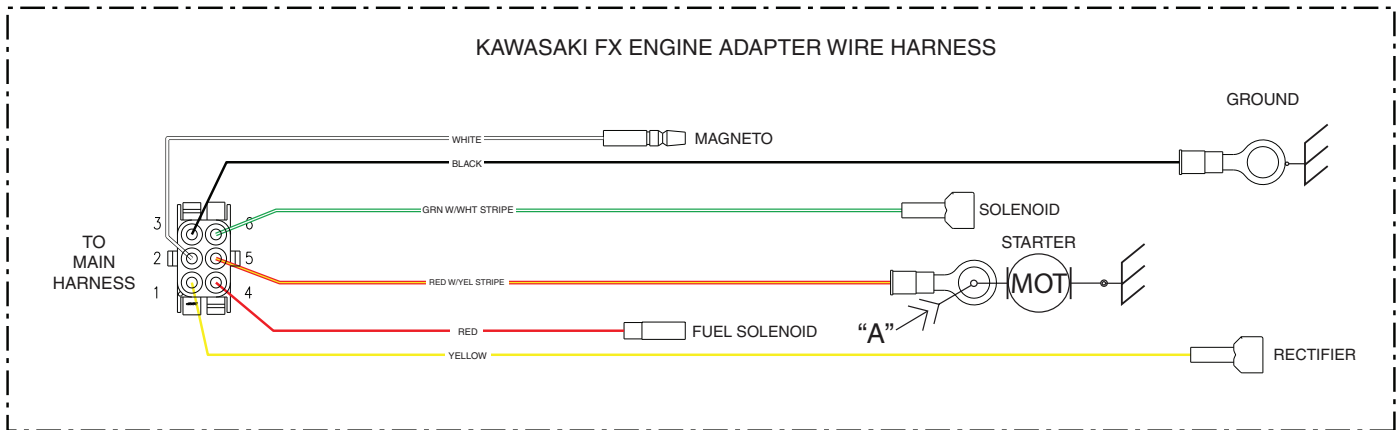

STCII YAMAHA MX ENGINE ADAPTER ELECTRICAL SCHEMATIC P/N 487063

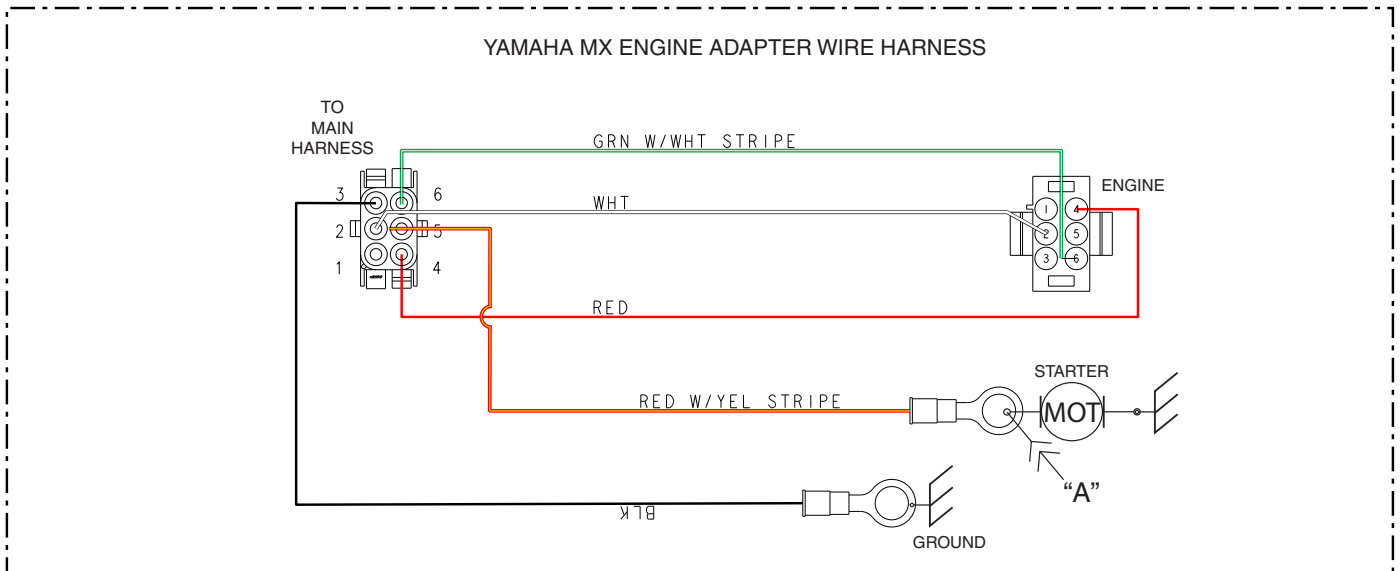

STCII - KOHLER 25CV-EFI ELECTRICAL SCHEMATIC
STCII - BRIGGS & STRATTON 28BV-EFI / 32BV ELECTRICAL SCHEMATIC
STCII - YAMAHA MX-EFI

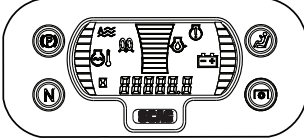
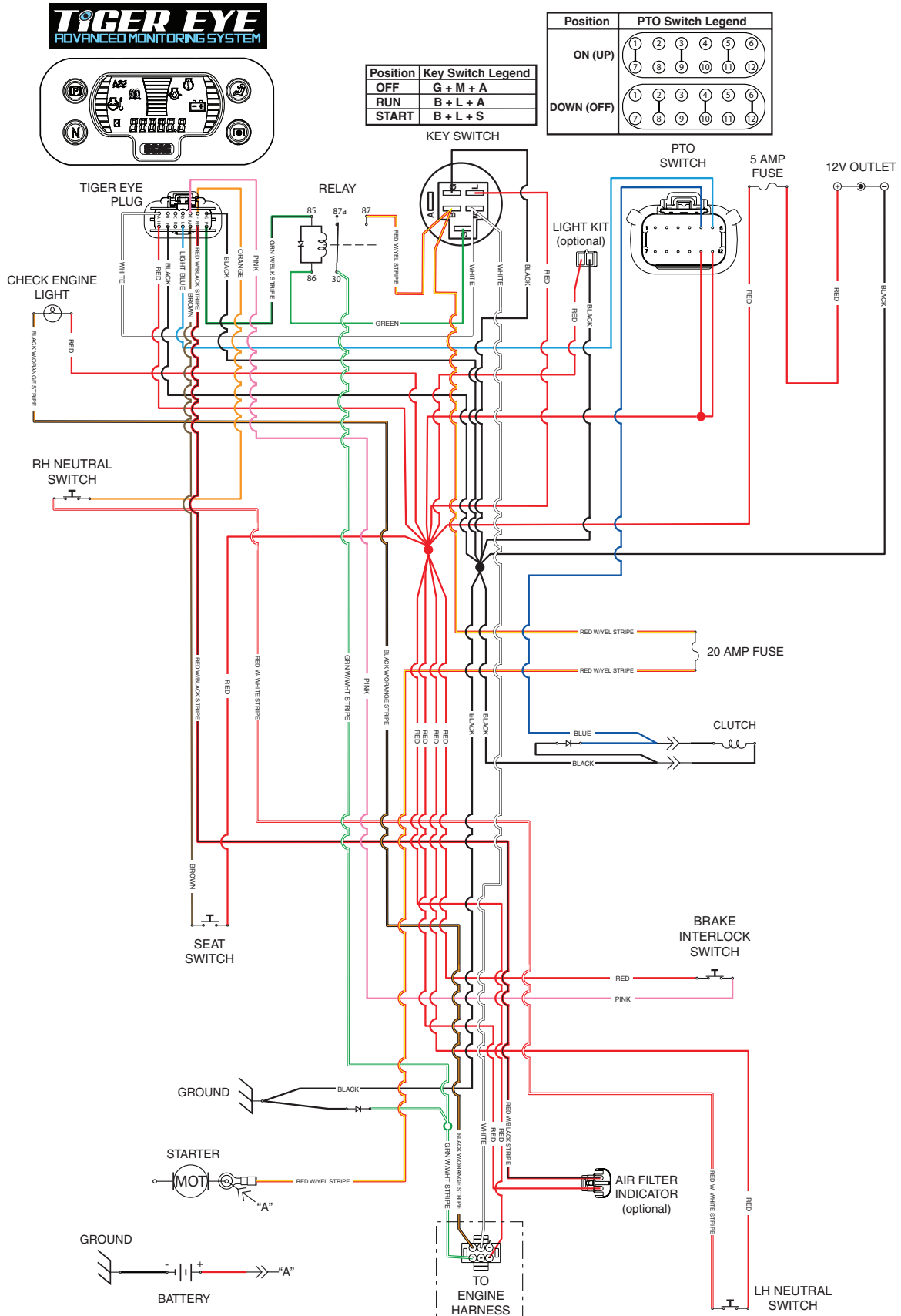

Position	Key Switch Legend
OFF	G + M + A
RUN	B + L + A
START	B + L + S

Position	PTO Switch Legend
ON (UP)	(1) (2) (3) (4) (5) (6)
	(7) (8) (9) (10) (11) (12)
DOWN (OFF)	(1) (2) (3) (4) (5) (6)
	(7) (8) (9) (10) (11) (12)

STCII BRIGGS & STRATTON 28BV-EFI ENGINE ADAPTER ELECTRICAL SCHEMATIC P/N 486946

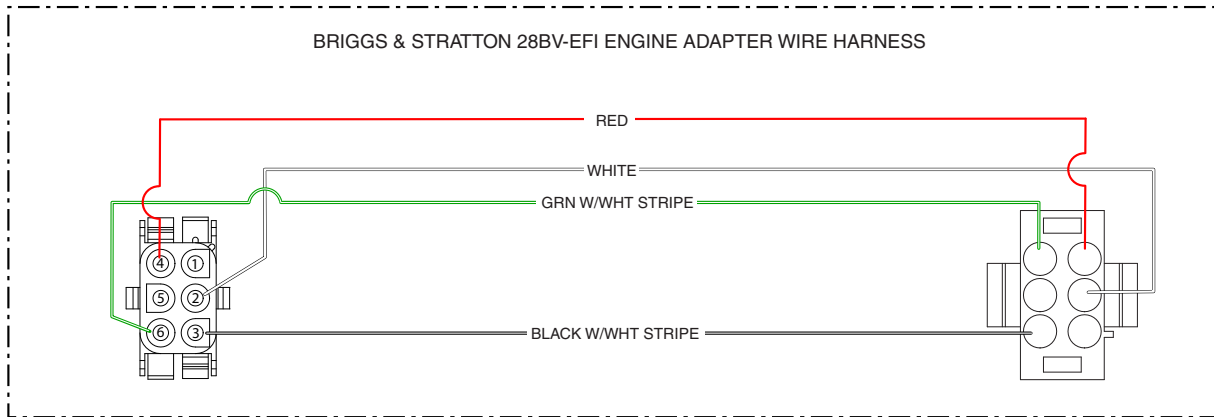

STCII BRIGGS & STRATTON 32BV ENGINE ADAPTER ELECTRICAL SCHEMATIC P/N 486139

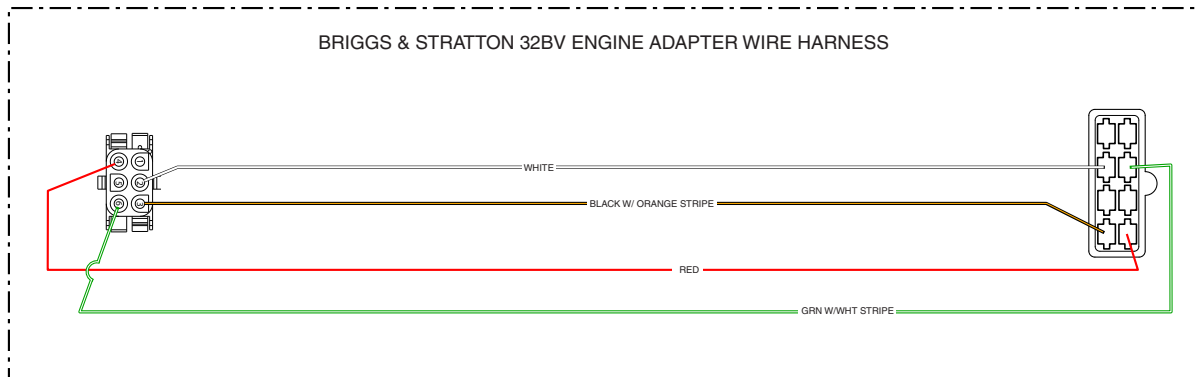

LIMITED WARRANTY - COMMERCIAL EQUIPMENT

Any part of the Scag commercial mower manufactured by Scag Power Equipment and found, in the reasonable judgment of Scag, to be defective in materials or workmanship, will be repaired or replaced by an Authorized Scag Service Dealer without charge for parts and labor during the periods specified below. This warranty is limited to the original purchaser provided the product was purchased from an Authorized Scag Power Equipment Dealer and is not transferable. Proof of purchase will be required by the dealer to substantiate any warranty claims. All warranty work must be performed by an Authorized Scag Service Dealer.

This warranty is limited to the following specified periods from the date of the original retail purchase for defects in materials or workmanship:

- Wear items including drive belts, blades, hydraulic hoses and tires are warranted for ninety (90) days.
- Batteries are covered for ninety (90) days.
- Frame and structural components including oil reservoir and oil coolers are warranted for two (2) years (parts and labor) for commercial use or three (3) years / 500 hours (whichever comes first) (parts and labor) for non-commercial use.
- Cutter decks are warranted against cracking for a period of three (3) years. (parts and labor 1st and 2nd year; parts only 3rd year.) The repair or replacement of the cutter deck will be at the option of Scag Power Equipment. We reserve the right to request components for evaluation. This warranty does not cover any mower that has been subject to misuse, neglect, negligence, or accident, or that has been operated in any way contrary to the operating instructions as specified in the Operator's Manual.
- Engines and electric starters are covered by the engine manufacturer's warranty period.
- Major drive system components are warranted for two (2) years (parts and labor) for commercial use or three (3) year / 500 hour (whichever comes first) (parts and labor) for non-commercial use by Scag Power Equipment. (commercial and non-commercial warranty excludes fittings, hoses, drive belts). The repair or replacement of the hydraulic pump or hydraulic motor will be at the option of Scag Power Equipment. This warranty does not cover any mower that has been subject to misuse, neglect, negligence, or accident, or that has been operated in any way contrary to the operating instructions as specified in the Operator's Manual.
- Electric clutches have a Limited Warranty for two (2) years (parts and labor) for commercial use or three (3) year / 500 hours (whichever comes first) (parts and labor) for non-commercial use.
- Spindle assemblies have a Limited Warranty for three years (parts and labor 1st year and 2nd; parts only 3rd year).
- Any Scag product used for rental purposes is covered by a 90 day warranty.

The Scag mower, including any defective part must be returned to an Authorized Scag Service Dealer within the warranty period. The expense of delivering the mower to the dealer for warranty work and the expense of returning it to the owner after repair will be paid for by the owner. Scag's responsibility is limited to making the required repairs and no claim of breach of warranty shall be cause for cancellation or rescission of the contract of sale of any Scag mower. "Non-Commercial" use is defined as a single property owner, where the single property is the residence of the owner of the mower. If the mower is cutting more than the owners single property, it is deemed commercial use and the "non-commercial" warranty does not apply. Scag Power Equipment reserves the right to deny and / or void the non-commercial warranty if it believes it to be in commercial use.

This warranty does not cover any mower that has been subject to misuse, neglect, negligence, or accident, or that has been operated in any way contrary to the operating instructions as specified in the Operator's Manual. The warranty does not apply to any damage to the mower that is the result of improper maintenance, or to any mower or parts that have not been assembled or installed as specified in the Operator's Manual and Assembly Manual. The warranty does not cover any mower that has been altered or modified, changing performance or durability. In addition, the warranty does not extend to repairs made necessary by normal wear, or by the use of parts or accessories which, in the reasonable judgment of Scag, are either incompatible with the Scag mower or adversely affect its operation, performance or durability.

Scag Power Equipment reserves the right to change or improve the design of any mower without assuming any obligation to modify any mower previously manufactured. All other implied warranties are limited in duration to the two (2) year for commercial use, three (3) years / 500 hour for non-commercial use or ninety (90) days for mowers used for rental purpose. Accordingly, any such implied warranties including merchantability, fitness for a particular purpose, or otherwise, are disclaimed in their entirety after the expiration of the appropriate two year, three year / 500 hour or ninety day warranty period. Scag's obligation under this warranty is strictly and exclusively limited to the repair or replacement of defective parts and Scag does not assume or authorize anyone to assume for them any other obligation. Some states do not allow limitations on how long an implied warranty lasts, so the above limitation may not apply to you.

Scag assumes no responsibility for incidental, consequential or other damages including, but not limited to, expense for gasoline, expense of delivering the mower to an Authorized Scag Service Dealer and expense of returning it to the owner, mechanic's travel time, telephone or telegram charges, rental of a like product during the time warranty repairs are being performed, travel, loss or damage to personal property, loss of revenue, loss of use of the mower, loss of time or inconvenience. Some states do not allow the exclusion or limitation of incidental or consequential damages, so the above limitation or exclusion may not apply to you. This warranty gives you specific legal rights, and you may also have other rights which vary from state to state.

