

SCAG[®]

POWER EQUIPMENT

OPERATOR'S MANUAL

TRUCK LOADER Industrial Tow Behind

**Model: TLB25-35BV
TLB25-37CH**



Congratulations on owning a Scag truck loader! This manual contains the operating instructions and safety information for your Scag truck loader. Reading this manual can provide you with assistance in maintenance and adjustment procedures to keep your truck loader performing to maximum efficiency. The specific models that this book covers are listed on the inside cover. Before operating your truck loader, please read all the information enclosed.



WARNING

FAILURE TO FOLLOW SAFE OPERATING PRACTICES MAY RESULT IN SERIOUS INJURY OR DEATH.

- Read this manual completely as well as other manuals that came with your truck loader.
- ALWAYS FOLLOW OSHA APPROVED OPERATION.
- Become familiar with the safe operation of the equipment, operator controls and safety signs.
- Check operation of brake, tail, marker and license plate lights frequently. Replace as required.
- Make sure the operator of the tow vehicle has the operator of the truck loader in full view at all times. Also, when operating the unit, instruct the operator to stay to the side of the machine, never in front or behind.
- Keep all shields and guards securely in place.
- Be sure all safety features are attached, adjusted and functioning properly.
- Before performing any maintenance or service, stop the machine and remove the spark plug wire.
- If a mechanism becomes clogged, stop the engine and wait for all moving parts to stop before cleaning.
- Keep hands, feet and clothing away from power-driven parts.

REMEMBER - YOUR TRUCK LOADER IS ONLY AS SAFE AS THE OPERATOR!

HAZARD CONTROL AND ACCIDENT PREVENTION ARE DEPENDENT UPON THE AWARENESS, CONCERN, PRUDENCE, AND PROPER TRAINING OF THE PERSONNEL INVOLVED IN THE OPERATION, TRANSPORT, MAINTENANCE, AND STORAGE OF THE EQUIPMENT.

This manual covers the operating instructions and illustrated parts list for:

TLB25-35BV

with a serial number of

T2200001 to T2299999

TLB25-37CH

with a serial number of

T2300001 to T2399999

Always use the entire serial number listed on the serial number tag when referring to this product.

Table of Contents

SECTION 1 - GENERAL INFORMATION	1
1.1 INTRODUCTION.....	1
1.2 DIRECTION REFERENCE	1
1.3 SERVICING THE ENGINE AND DRIVE TRAIN COMPONENTS.....	1
1.4 SYMBOLS	2
SECTION 2 - SAFETY INFORMATION	3
2.1 INTRODUCTION.....	3
2.2 SIGNAL WORDS	3
2.3 BEFORE OPERATION CONSIDERATIONS.....	3
2.4 OPERATION CONSIDERATIONS.....	5
2.5 MAINTENANCE CONSIDERATIONS & STORAGE	6
2.6 USING A SPARK ARRESTOR.....	6
2.7 SPARK IGNITION SYSTEM	6
2.8 SAFETY AND INSTRUCTIONAL DECALS	7
SECTION 3 - SPECIFICATIONS	8
3.1 ENGINE	8
3.2 IMPELLER	8
3.3 WEIGHTS AND DIMENSIONS.....	8
SECTION 4 - OPERATING INSTRUCTIONS	10
4.1 CONTROLS AND INSTRUMENT IDENTIFICATION	10
4.2 INITIAL RUN-IN PROCEDURES.....	11
4.3 CONNECTING TO TOW VEHICLE	11
4.4 STARTING THE ENGINE	12
4.5 OPERATION	12
4.6 HILLSIDE OPERATION.....	13
4.7 UNCOUPLING THE UNIT FROM THE TOW VEHICLE	13
4.8 AFTER OPERATION	14
4.9 REMOVING CLOGGED MATERIAL	15
SECTION 5 - MAINTENANCE	16
5.1 MAINTENANCE CHART - RECOMMENDED SERVICE INTERVALS	16
5.2 ENGINE OIL	17
5.3 ENGINE FUEL SYSTEM	17
5.4 ENGINE AIR CLEANER.....	17
5.5 IMPELLER DRIVE BELT ADJUSTMENT	18
5.6 IMPELLER SHAFT BEARINGS.....	19
5.7 WHEELS & TIRES	19
5.8 TRAILER LIGHTS.....	19

SECTION 6 - ILLUSTRATED PARTS LIST	20
6.1 SCAG APPROVED ATTACHMENTS AND ACCESSORIES.....	20
INTAKE AND DISCHARGE ASSEMBLY	22
IMPELLER HOUSING ASSEMBLY.....	24
IMPELLER DRIVE ASSEMBLY	26
TRAILER ASSEMBLY	28
FUEL AND ELECTRICAL SYSTEM	30
TLB25 - TRUCK LOADER DECALS.....	32
TLB25 - TRAILER LIGHT WIRING DIAGRAM.....	33
LIMITED WARRANTY - TRUCK LOADERS.....	34

GENERAL INFORMATION

1.1 INTRODUCTION

Your Scag product was built to the highest standards in the industry. However, the prolonged life and maximum efficiency of your truck loader depends on you following the operating, maintenance and adjustment instructions in this manual.

If additional information or service is needed, contact your Scag Power Equipment Dealer.

We encourage you to contact your dealer for repairs. All Scag dealers are informed of the latest methods to service this equipment and provide prompt and efficient service in the field or at their service shop. They carry a full line of Scag service parts.

- IMPORTANT -

The replacement of any part on this product by other than the manufacturer's authorized replacement part may adversely affect the performance, durability or safety of this product.

Use of other than original Scag replacement parts will void the warranty.

When ordering parts, always give the model and serial number of your product. The serial number plate is located on the frame next to the engine.

USE ONLY SCAG APPROVED ATTACHMENTS AND ACCESSORIES.

Attachments and accessories manufactured by companies other than Scag Power Equipment are not approved for use on this machine. See Section 6-1.

WARNING

For pictorial clarity, some illustrations and figures in this manual may show shields, guards or plates open or removed. Under no circumstances should this product be operated without these devices in place.

All information is based upon product information available at the time of approval for printing. Scag Power Equipment reserves the right to make changes at any time without notice and without incurring any obligation.











1.2 DIRECTION REFERENCE

The "Right" and "Left", "Front" and "Rear" of the machine are referenced from the operator's right and left when in the normal operating position and facing the forward travel direction.

1.3 SERVICING THE ENGINE AND DRIVE TRAIN COMPONENTS

Details regarding the service and repair of the engine are not covered in this manual; only routine maintenance and general service instructions are provided. For service of these components during the limited warranty period, it is important to contact your Scag dealer or find a local authorized servicing agent of the component manufacturer. Any unauthorized work done on these components during the warranty period may void your warranty.

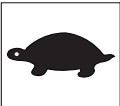
1.4 SYMBOLS

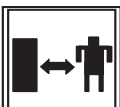
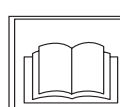
SYMBOL	DESCRIPTION	SYMBOL	DESCRIPTION
	Choke		Transmission
	On/Start		Spring Tension on Idler
	Off/Stop		Oil
	Spinning Fan Blades		Thrown Object Hazard
	Fast		Slow
	Continuously Variable - Linear		Pinch Point
	Keep Bystanders Away		Read Operator's Manual

SAFETY INFORMATION

2.1 INTRODUCTION

Your truck loader is only as safe as the operator. Carelessness or operator error may result in serious bodily injury or death. Hazard control and accident prevention are dependent upon the awareness, concern, prudence, and proper training of the personnel involved in the operation, transport, maintenance and storage of the equipment. Make sure every operator is properly trained and thoroughly familiar with all of the controls before operating. The owner/user can prevent and is responsible for accidents or injuries occurring to themselves, other people or property.

READ THIS OPERATOR'S MANUAL BEFORE ATTEMPTING TO START YOUR TRUCK LOADER.

A replacement manual is available from your authorized Scag Service Dealer or by contacting Scag Power Equipment Service Department at P.O. Box 152, Mayville, WI 53050 or contact us via the Internet at www.scag.com. The manual for this machine can be downloaded by using the model and serial number or use the contact form to make your request. Please indicate the complete model and serial number of your Scag product when requesting replacement manuals.

2.2 SIGNAL WORDS



This symbol means "**Attention! Become Alert! Your Safety is Involved!**" The symbol is used with the following signal words to attract your attention to safety messages found on the decals on the machine and throughout this manual. The message that follows the symbol contains important information about safety. To avoid injury and possible death, carefully read the message! Be sure to fully understand the causes of possible injury or death.

SIGNAL WORD:

It is a distinctive word found on the safety decals on the machine and throughout this manual that alerts the viewer to the existence and relative degree of the hazard.

DANGER

The signal word "DANGER" denotes that an extremely hazardous situation exists on or near the machine that could result in high probability of death or irreparable injury if proper precautions are not taken.

WARNING

The signal word "WARNING" denotes that a hazard exists on or near the machine that can result in injury or death if proper precautions are not taken.

CAUTION

The signal word "CAUTION" is a reminder of safety practices on or near the machine that could result in personal injury if proper precautions are not taken.

Your safety and the safety of others depends significantly upon your knowledge and understanding of all correct operating practices and procedures of this machine.

2.3 BEFORE OPERATION CONSIDERATIONS

1. Check the engine oil level and add oil as needed to bring the level up to the FULL mark. See engine owner's manual for oil specifications.
2. NEVER allow children to operate this machine. Do not allow adults to operate this machine without proper instructions.
3. Keep bystanders, children and pets away from the machine.
4. Do not operate when children and/or others are present. Keep children out of the work area and in the watchful care of a responsible adult other than the operator. Be alert and turn machine off if a child enters the area.
5. DO NOT allow children to ride or play on the machine, it is not a toy.

6. DO NOT operate the machine under the influence of alcohol or drugs.
7. Before and during reverse operation, look behind and down for small children and/or pets.
8. If the operator(s) or mechanic(s) cannot read English, it is the owner's responsibility to explain this material to them.
9. DO NOT wear loose fitting clothing. Loose clothing, jewelry or long hair could get tangled in moving parts. Do not operate the machine wearing shorts; always wear adequate protective clothing including long pants. Wearing safety glasses, safety shoes and a helmet is advisable and is required by some local ordinances and insurance regulations.

WARNING

Always wear hearing protection. Operating this machine over prolonged periods of time can cause loss of hearing.

10. Keep the machine and attachments in good operating condition. Keep all shields and safety devices in place. If a shield, safety device or decal is defective or damaged, repair or replace it before operating the machine.

WARNING

Belts, belt guards, hoses, intake nozzles and discharge tubes are subject to wear, damage and/or deterioration, which could expose moving parts or allow objects to be thrown. Frequently check components and replace with manufacturer's recommended parts when necessary.

11. Thoroughly inspect the area where the equipment is to be used and remove all foreign objects.
12. Evaluate the terrain to determine what accessories and attachments are needed to properly and safely perform the job. Use only approved attachments and accessories.
13. See Section 5.3 ENGINE FUEL SYSTEM for fueling procedure.
14. Use a funnel or spout to prevent spillage.
15. Never refuel indoors.

16. Keep flammable objects (cigarettes, matches, etc.), open flames and sparks away from the fuel tank and fuel container. Use only approved containers.

WARNING

Fuel is highly flammable. Take the following precautions:

Store fuel in containers specifically designed for this purpose.

Refuel outdoors only and do not smoke while refueling.

Add fuel before starting the engine. Never remove the cap on the fuel tank or add fuel while the engine is running or when the engine is hot.

If fuel is spilled, do not attempt to start the engine but move the machine away from the area of spillage and avoid creating any source of ignition until fuel vapors have disappeared.

Replace all fuel tank and container caps securely.

17. Check the inlet hose, discharge tube, wear liners, impellers, debris receiver box and components frequently for signs of wear or deterioration and replace as needed to prevent injury from thrown objects going through weak or torn spots.
18. Never attempt to make any adjustments while the engine is running unless specifically recommended by the manufacturer.
19. Check the engine mounting bolts at frequent intervals for proper tightness.
20. Use care when hooking or unhooking the machine to a tow vehicle.
21. Check operation of brake, tail, side marker and license plate lights frequently. Replace failed or damaged parts as needed.

Section 2

2.4 OPERATION CONSIDERATIONS

This truck loader is designed for use at highway speeds in normal conditions.

CAUTION

Tow at speeds appropriate for conditions. Reduce speeds for:

- Rough Roads
- Winding Roads
- Cornering
- Adverse weather including rain, snow, ice and high winds

1. Know the function of all controls and how to stop quickly in case of an emergency.
2. Do not carry passengers. Keep bystanders, children and pets away from the machine.
3. Make sure the hose and boom are secured before transporting your Truck Loader.
4. Do not operate without the discharge connected to a debris receiver box.
5. Do not overload the machine by attempting to chip or shred any material beyond the manufacturer's recommendation.
6. Do not operate on slopes if you are uneasy or uncertain. Ultimate responsibility for safe operation on slopes rests with the operator.
7. Exercise extreme caution when making turns or changing direction on slopes. Keep all movements slow and gradual.
8. Slow down and use caution when making turns and crossing roads and side walks.
9. Be sure of your footing. Poor footing could cause a slip and fall accident.
10. When using this machine, never direct the material being collected toward bystanders or allow anyone near the machine while in operation.
11. Do not operate around cars, windows, or other items which could be damaged by blown debris.

12. Before attempting to start the engine, inspect the machine, inlet hose, discharge, debris receiver box, shields and safety devices for any damage. Correct any problems before operating.
13. Stop on level ground and shut off the engine before leaving the operator's position for any reason including emptying the debris box or clearing an obstruction in the intake or discharge.
14. If the truck loader ever plugs, shut off the engine, and wait for all movement to stop before removing the obstruction.

WARNING

DO NOT use your hand to dislodge the clogged material. Use a stick or other device to remove clogged material after the engine has stopped running and the blower fan has stopped turning.

15. If the machine begins to vibrate abnormally, shut the machine off immediately. Inspect the machine and have repairs made before restarting.
16. Be alert for holes, rocks, roots and other hidden hazards in the terrain. Cautiously enter a new area. Be alert for hidden hazards.
17. Do not operate near drop-offs, ditches or embankments. You could lose your footing, balance or drive the machine off the edge.
18. Use only in daylight or good artificial light.
19. Do not leave the machine unattended.
20. The machine and attachments should be stopped and inspected for damage after striking a foreign object, and damage should be repaired before restarting and operating the machine.
21. Keep hands and feet away from blower intake and discharge. Contact can injure.

CAUTION

Do not touch the engine or the muffler while the engine is running or immediately after stopping. These areas may be hot enough to cause a burn.

DANGER

DO NOT run the engine inside a building or a confined area without proper ventilation. Exhaust fumes are hazardous and contain carbon monoxide which can cause brain injury and death.

22. Keep hands and feet away from all other moving parts. Contact can injure.
23. Use care when approaching blind corners, shrubs, trees, or other objects that may obscure vision.
24. NEVER leave the machine running unattended.

2.5 MAINTENANCE CONSIDERATIONS & STORAGE

1. Check wear liners and impeller on a regular basis for bent, worn or cracked blades. Only replace impellers. Do not straighten or weld the impeller fan.
2. Never make adjustments to the machine with the engine running unless specifically instructed to do so. If the engine is running, keep hands, feet, and clothing away from moving parts.
3. Never operate the machine when uncoupled from the tow vehicle.
4. Disconnect spark plug wire to prevent accidental starting of the engine when servicing or adjusting the machine. Wait for all movement to stop before adjusting, cleaning or repairing.
5. Keep all nuts, bolts and screws tight, especially the impeller bolt, to ensure the machine is in safe working condition.
6. Do not change the engine governor settings or overspeed the engine. See the engine operator's manual for information on engine settings.
7. To reduce fire hazard, keep the muffler and engine free of grass, leaves, excessive grease, oil and dirt.
8. Park the machine on level ground.
9. Block the wheels to prevent the machine from moving.
10. Lower the Support Leg to the ground and secure with the spring latch when the machine is not attached to a tow vehicle. See Figure 2-1.

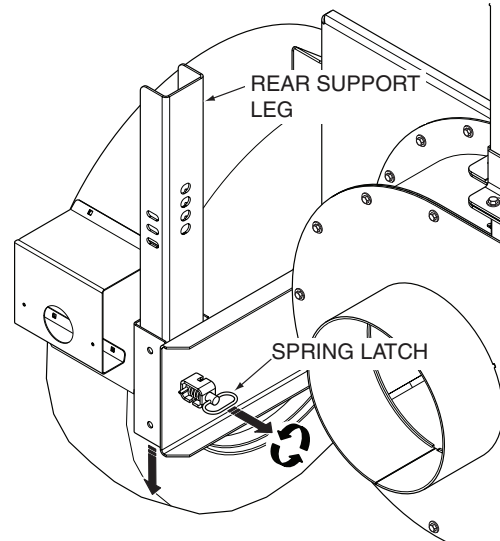

Figure 2-1. Lowering the Rear Support Leg

11. NEVER allow untrained personnel to service the machine.
12. Keep all parts in good working condition. Replace all worn or damaged decals.
13. Use jack stands to support components when required.
14. Let the engine cool before storing.
15. Keep the unit locked in a secure location and disconnect the battery to prevent unauthorized personnel, especially children, from playing and/or tampering with the unit.
16. DO NOT store the machine near an open flame.
17. Always follow the engine manufacturer's recommendation for storing and returning to service.
18. Shut off fuel while storing or transporting.

2.6 USING A SPARK ARRESTOR



The engine on this machine may not be equipped with a spark arrestor muffler. It is in violation of California Public Resource Code Section 4442 to use or operate this engine on or near any forest covered, brush covered or grass covered land unless the exhaust system is equipped with a spark arrestor meeting any applicable local or state laws. Other states or federal areas may have similar laws. Check with your state or local authorities for regulations pertaining to these requirements.

2.7 SPARK IGNITION SYSTEM



This spark ignition system complies with Canadian ICES-002.

Section 2

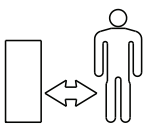
2.8 SAFETY AND INSTRUCTIONAL DECALS

 DANGER	
	<p>ROTATING BLOWER BLADES & FLYING MATERIAL CONTACT CAN INJURE</p> <ul style="list-style-type: none"> * Do not operate without all guards and shields in place. * Do not bypass or disable any safety devices.
	<p>Do not operate without vacuum hose installed.</p> <ul style="list-style-type: none"> * Stop engine & remove spark plug wire before any adjustment, maintenance, or repair. * Do not leave the operator's position with the engine running.
	<ul style="list-style-type: none"> * Do not vacuum any debris that is burning, wet, flammable, explosive, or poisonous. * Do not refuel with engine running or hot. Add fuel only when engine is cool and with the machine in an open area * Keep bystanders away. * Read operator's manual. 485122

485122

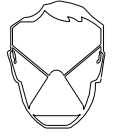
 CAUTION		
		
<p>WEAR PROTECTION FOR HEARING, VISION & BREATHING</p> <p style="text-align: right;"><small>484983</small></p>		

484983



 WARNING

<p>Burn Hazard</p> <p>Contact can cause serious injury.</p> <p>DO NOT TOUCH</p> <p style="text-align: right;"><small>485139</small></p>

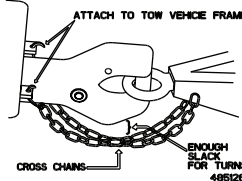
485139

 WARNING		
<p>TOWING DISCONNECT</p> <p>Park on level ground when disconnecting. Wheels must be chocked in direction of grade before disconnecting from vehicle. Lower rear support arm. Remove tow chains from vehicle frame. Disconnect running lights from vehicle. Disengage hitch from towing vehicle. *Read operator's manual*</p>	<p>FOR TOWING</p> <p>Always use safety chains. Cross chains underneath coupler with slack for turns. Attach chain hooks securely to tow vehicle frame. Connect hitch and running lights to towing vehicle. No standing, riding, or sitting on machine at anytime. Be sure tow vehicle hitch is rated for GVWR shown on vehicle certification decal. Tow at speeds appropriate for conditions.</p>	

485126

 DANGER	
	<p>Avoid injury from burns</p> <ul style="list-style-type: none"> - Shut off engine - Allow to cool several minutes - Remove cap slowly - Do not overfill <p style="text-align: right;"><small>484281</small></p>

484281

 WARNING
<p>Operation of this equipment may create sparks that can start fires around dry vegetation. A spark arrester may be required. The operator should contact local fire agencies for laws or regulations relating to fire prevention requirements.</p> <p style="text-align: right;"><small>483900</small></p>

483900
California Only

SPECIFICATIONS

3.1 ENGINE

General Type	Heavy Duty Industrial/Commercial Gasoline
Model:	
(Scag TLB25-37CH)	Kohler Command CH1000
(Scag TLB25-35BV)	Briggs & Stratton Vanguard
Displacement:	
Kohler CH1000	999cc
Briggs & Stratton Vanguard	993cc
Type:	
Kohler (CH1000).....	4-Cycle, Air Cooled, Naturally Aspirated, OHV
Briggs & Stratton Vanguard	4-Cycle, Air-Cooled, Naturally Aspirated, OHV
Cylinders.....	2 with Cast Iron Sleeves
Governor.....	Mechanical Type with Variable Speed Control Set At 3600 RPM
Idle Speed:	
Kohler	1400 RPM
Briggs & Stratton	1750 RPM
Carburetion:	
Kohler (CH1000).....	Fixed Jet
Briggs & Stratton	Fixed Jet
Fuel Pump:	
Kohler	Mechanical with In-Line Fuel Filter
Briggs & Stratton	Mechanical with In-Line Fuel Filter
Fuel.....	Non-Leaded Gasoline with a Minimum Octane Rating of 87, E10 Max.
Oil Pump.....	Full Pressure w/Full-Flow Filter
Starter.....	Electric Starting with Solenoid Shift

3.2 IMPELLER

Impeller Diameter	Balanced 25" Steel with Tapered Locking Hub
Number of Blades.....	4 - Blade, 1/2"
CFM (cubic feet / min.) - TLB25-37CH	6909
CFM (cubic feet / min.) - TLB25-35BV	6781
Wear Liner	1/4" Steel
Intake Hose	7' x 16"
Discharge	6' x 12"

3.3 WEIGHTS AND DIMENSIONS

Hitch Height.....	Adjustable
Hitch Ball Diameter.....	2-5/16" (optional Pintle)
Hitch Class Required.....	Class III
Discharge Height.....	121-1/4"
Weight	1700#
Tire Size:	
(2) Rear -	ST205/17 D15
Tire Pressure:	
(2) Rear	50 PSI Max.

OPERATING INSTRUCTIONS

⚠ CAUTION

Do not attempt to operate this machine unless you have read this manual. Learn the location and purpose of all controls and instruments before you operate.

4.1 CONTROLS AND INSTRUMENT IDENTIFICATION

Before operating the truck loader, familiarize yourself with all truck loader and engine controls. Knowing the location, function and operation of these controls is important for safe and efficient operation.

1. **Ignition Switch (Figure 4-1).** The ignition switch is used to start the engine and has three positions; OFF, ON, and START.
2. **Engine Throttle Control (Figure 4-1).** Used to control the engine speed. Pushing the lever inboard increases engine speed. Pulling the lever outboard decreases engine speed. Full outboard position is the IDLE position. Full inboard is the operating position.
3. **Engine Choke Control (Figure 4-1).** Used to start a cold engine.
4. **Tongue Jack (Figure 4-1).** Used to raise and lower the ball hitch receiver or optional pintle hitch onto or off of the tow vehicle.
5. **Safety Chains (Figure 4-1).** Used to connect to the tow vehicles cradle draw bar in criss-cross fashion in case of an accidental disconnect.

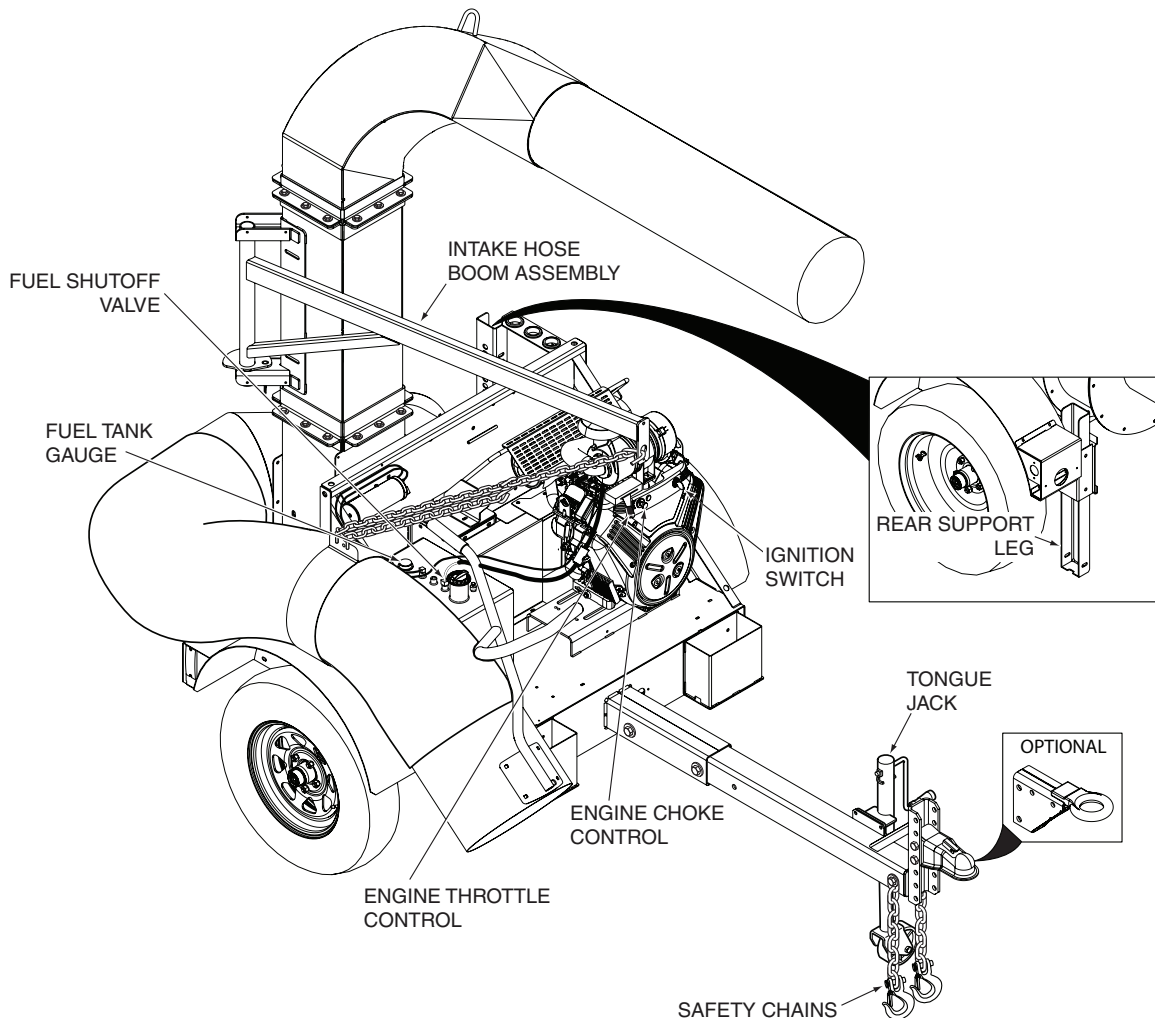

Figure 4-1. Controls and Instruments

Section 4

6. **Rear Support Leg (Figure 4-1).** Used to support the truck loader when disconnected from the tow vehicle.

WARNING

Failure to lower the Rear Support Leg when the Truck Loader is not connected to a tow vehicle can result in unit rollover, unit damage and personal injury.

7. **Fuel Tank Gauge (Figure 4-1).** Indicates the amount of fuel in the fuel tank.
8. **Fuel Shutoff Valve (Figure 4-1).** Located on the fuel tank. Used to shut off fuel supply to the engine. Rotate the valve counter clockwise to supply fuel. Rotate the valve clockwise to shut off fuel supply.
9. **Intake Hose Boom Assembly (Figure 4-1).** Used to support the intake hose. The support chain can be raised or lowered until the intake nozzle floats 2-3 inches from the ground to help make operation easy and comfortable.

4.2 INITIAL RUN-IN PROCEDURES

FIRST DAY OF USE OR APPROXIMATELY 20 HOURS

1. Change the engine oil and oil filter after the first 20 hours of operation. (See Section 5.2).
2. Check for loose hardware. Tighten as needed.
3. Check tire pressure. Adjust pressure if necessary. (See Section 5.5).

4.3 CONNECTING TO TOW VEHICLE

1. Back the tow vehicle up to the truck loader.
2. Raise or lower the tongue jack until the ball coupler on the truck loader is approximately 3-4 inches higher than the ball hitch on the tow vehicle. Flip the lock lever up on the ball hitch coupler.
3. With assistance behind, back up slowly, align the ball hitch coupler and ball hitch.
4. Lower the front of the truck loader using the wheel jack until the ball hitch coupler drops completely onto the ball hitch. Rock the truck loader back and forth several times to ensure full coupling of the ball hitch.

5. Lock the ball hitch coupler lever. Use a clevis pin or padlock through the locking hole in the lever to prevent accidental disconnect.
6. Connect the safety chains to the tow vehicle in criss-cross fashion to the cradle draw bar in case of accidental disconnect. See Figure 4-2.

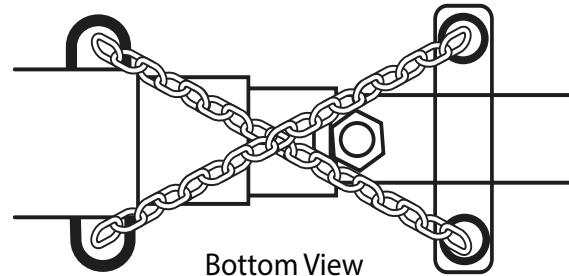

Figure 4-2. Safety Chains

7. Connect the trailer wiring plug to the trailer socket on the tow vehicle and check for proper operation of all lights and signal indicators.

-NOTE-

The Truck Loader is equipped with a 7-Way flat spade connector. If the tow vehicle is equipped with anything other than a 7-Way flat spade connector, an adapter will be required.

8. Pull and turn the spring latch to unlock the pin securing the rear support leg in the lowered position. See Figure 4-3.

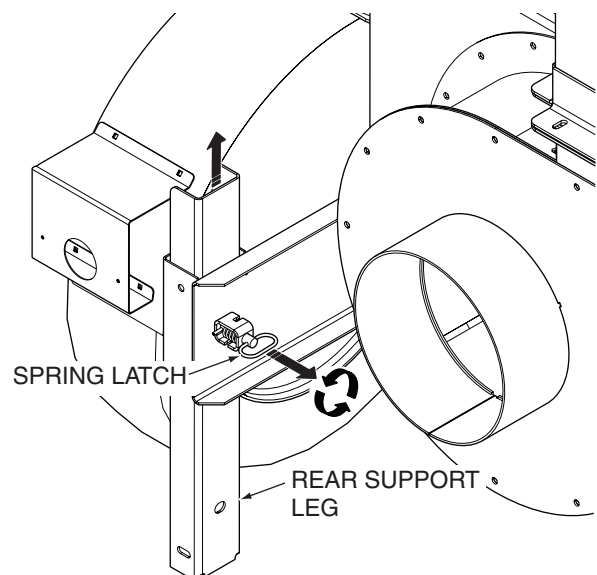

Figure 4-3. Raising the Rear Support Leg

9. Raise the rear support leg and secure in the transport position using the spring latch.

4.4 STARTING THE ENGINE

CAUTION

DO NOT USE STARTING FLUIDS. Use of starting fluids in the air intake system may be potentially explosive or cause a “runaway” engine condition that could result in engine damage and/or personal injury.

1. Move the machine to a flat open area.
2. Be sure the fuel shutoff valve, located on the fuel tank, is completely open. See Figure 4-1.
3. Move the engine throttle control to about half engine speed. If starting a cold engine, pull the engine control all the way out to engage the choke.
4. Turn the ignition key to the START position and release the key as soon as the engine starts. Do not hold the key in the START position for more than 15 seconds at a time. Allow at least 60 seconds between each cranking attempt to prevent overheating of the starter motor. Prolonged cranking can damage the starter motor and shorten battery life.
5. Allow engine to warm before operating the truck loader.

4.5 OPERATION

This truck loader has been designed to pick up dry organic debris such as leaves, grass clippings, shavings and small amounts of sand. Vacuuming hard non-organic material will affect the life of your machine. Sand is abrasive and will produce wear of items including the blower housing, wear liners, impeller and nose cone.

WARNING

DO NOT operate the machine without being attached to a tow vehicle and debris box. Always wear eye, ear and breathing protection when operating machine.

1. Read Section 2.3 BEFORE OPERATION CONSIDERATIONS and Section 2.4 OPERATION CONSIDERATIONS before operating.

CAUTION

Tow at speeds appropriate for conditions. Reduce speeds for:

- Rough Roads
- Winding Roads
- Cornering
- Adverse weather including rain, snow, ice and high winds

2. Adjust the height of the intake nozzle. For maximum debris pickup, the intake nozzle should be as close to the debris as possible without blocking airflow and the engine speed should be set to "Fast".
3. Not all debris pick up will require that the engine speed be set to "Fast". You can experiment with the intake nozzle height and engine speed to best suit your conditions.
4. Operating in dry dusty conditions may require that the engine speed be set to a slower position to reduce the amount of small particles of debris escaping.
5. For peak performance, keep the debris box clean and do not overfill.
6. Make sure the driver of the tow vehicle has the operator in full view at all times.
7. When operating, instruct the operator to stay to the side of the machine, never in front or behind.

WARNING

DO NOT remove the Truck Loader from the tow vehicle or debris box with the engine running. STOP the engine and allow all rotation to stop.

8. If the intake nozzle or discharge becomes plugged, shut off the engine and remove the spark plug wire. The engine must come to a complete stop before attempting to remove obstruction from inlet nozzle or discharge area. Using a stick or similar item, dislodge the clogged material. Then resume normal operation.
9. Plan how to clear the area to reduce clearing time.

Section 4

10. Collecting debris into piles for the machine to intercept prior to start up will save time and fuel as well as wear and tear on the unit.
11. Keep the truck loader's intake nozzle and discharge clean.
12. Use a slow travel speed when clearing heavy or large amounts of material.

4.6 HILLSIDE OPERATION

Slopes are a major factor related to loss-of-control and tip over accidents which can result in severe injury or death. All slopes require extra caution.

WARNING

DO NOT operate on steep slopes. Poor footing could cause a slip and fall accident. ALWAYS FOLLOW OSHA APPROVED OPERATION.

1. Do not operate on slopes if you are uneasy or uncertain. Ultimate responsibility for safe operation on slopes rests with the operator.
2. Be sure of footing on slopes.
3. Caution must be used when operating on slopes, especially when the grass is wet. Wet grass reduces traction and control.
4. To prevent tipping or loss of control, keep all movements on slopes slow and gradual.
5. Do not turn on slopes unless necessary, and then turn slowly and down hill when possible.
6. Do not start or stop on slopes. If tires lose traction, stop the unit and proceed slowly straight down the slope.
7. Be alert for holes, rocks, roots, ruts and other hidden hazards in the terrain. Uneven terrain could cause a slip and fall accident.
8. Do not operate near drop-offs, ditches, or embankments. The operator could lose footing or balance or unit could suddenly turn over if a wheel is over the edge of a cliff or ditch, or if the edge caves in.

4.7 UNCOUPLING THE UNIT FROM THE TOW VEHICLE

1. Park the machine on a flat, level surface only. Do not park the machine on an incline.
2. Block the wheels to prevent the machine from moving. See Figure 4-4.

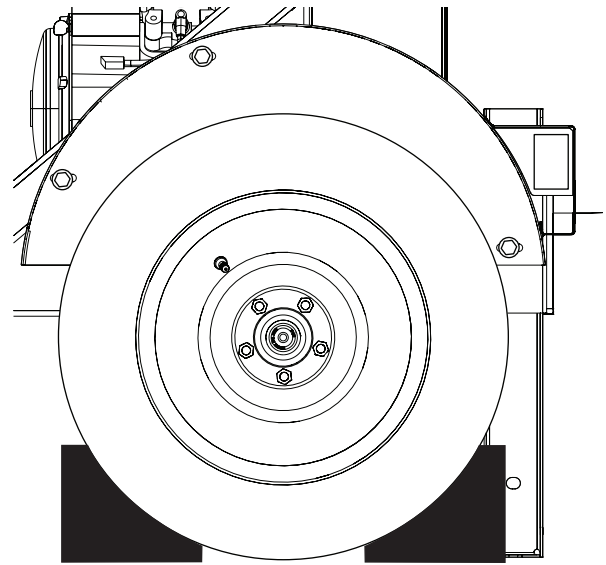

Figure 4-4. Wheel Chocks

3. Disconnect the trailer wiring plug from the tow vehicle.
4. Unhook the safety chains from the rear of the tow vehicle.
5. Unlock the ball hitch coupler lever on the unit and flip up.
6. Crank down the tongue jack until the ball hitch coupler on the unit clears the ball hitch on the tow vehicle.
7. Pull and turn the spring latch to unlock the pin securing the rear support leg in the transport position. See Figure 4-5.

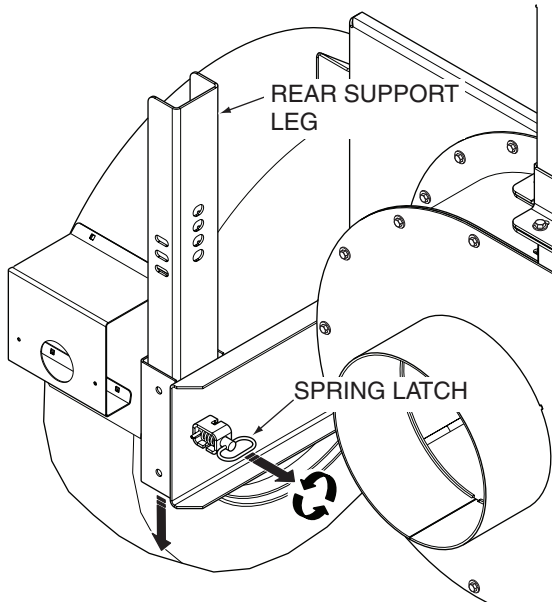

Figure 4-5. Lowering the Rear Support Leg

8. Lower the rear support leg to the lowermost position and secure with the spring latch.

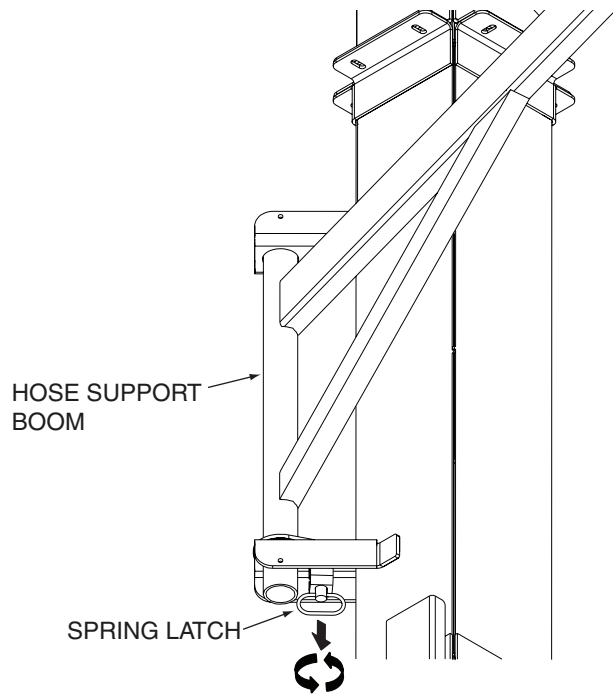

Figure 4-6. Locking the Hose Support Boom

WARNING

Failure to lower the Rear Support Leg when the Truck Loader is not connected to a tow vehicle can result in unit rollover, unit damage and personal injury.

9. Pull the tow vehicle away.

4.8 AFTER OPERATION

1. When machine is not in operation, in storage or transporting, lock the hose support boom and secure hose on the storage pin. Pull and turn the spring latch to lock the pin securing the hose support boom in the transport position. See Figure 4-6 & Figure 4-7.

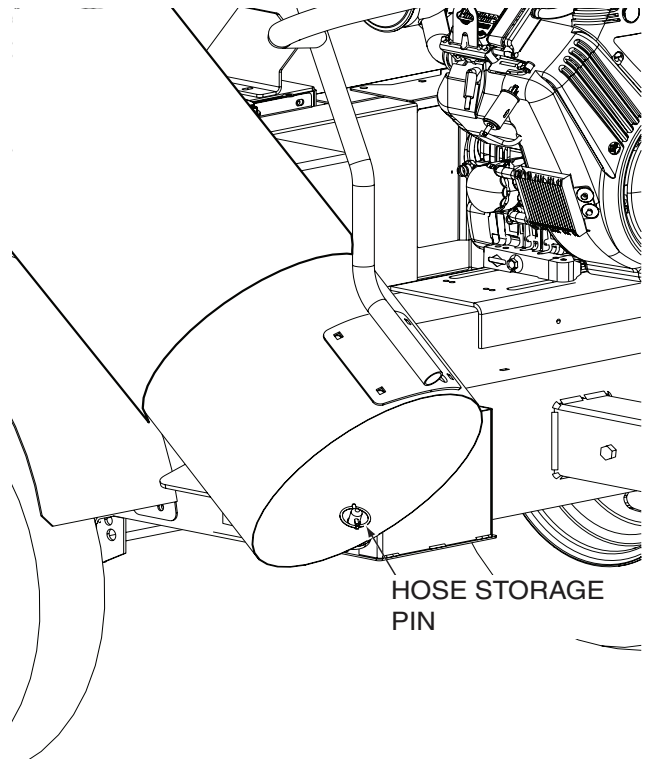

Figure 4-7. Hose Storage Pin

2. After the engine has cooled down, wash the entire machine after each use. Do not use high pressure spray or direct the spray onto electrical components.

Section 4**- IMPORTANT -**

Do not wash a hot or running engine. Cold water will damage the engine. Use compressed air to clean the engine if it is hot.

3. Keep the entire machine clean to inhibit serious heat damage to the engine.

**DANGER**

To avoid injury from burns, allow the engine to cool before removing the fuel tank cap and refueling.

4. Check the tire pressure. Adjust pressure if necessary.

4.9 REMOVING CLOGGED MATERIAL**DANGER****ROTATING FAN BLADES**

NEVER PUT YOUR HANDS INTO THE VACUUM INTAKE OR DISCHARGE FOR ANY REASON!

Shut off the engine, remove the spark plug wire and only then use a stick or similar object to remove material if plugging has occurred.

1. If the intake nozzle or discharge becomes plugged, shut off the engine and remove the spark plug wire. The engine must come to a complete stop before attempting to remove obstruction from intake nozzle or discharge area. Using a stick or similar item, dislodge the clogged material. Then resume normal operation.

MAINTENANCE

5.1 MAINTENANCE CHART - RECOMMENDED SERVICE INTERVALS

BREAK-IN (FIRST 10)	HOURS						PROCEDURE	COMMENTS
	8	20	50	100	200	500		
X							Check all hardware for tightness	
X							Check impeller drive belt tension	See Section 5.5
	X						Check engine oil level	See engine operator's manual
	X						*Clean truck loader	
	X						Check trailer lights for proper operation	Check Daily before operating
	X						Check condition of impeller blades and impeller housing	
	X						Check impeller drive belt tension	See Section 5.5
		X					Change engine oil and filter	See engine operator's manual
			X				*Clean air filter element	See engine operator's manual
			X				**Grease Impeller Shaft Bearings	See Below
				X			Check condition of fuel lines	
				X			Check all hardware for tightness	
				X			Change engine oil	See engine operator's manual
				X			*Clean air cleaner element	See engine operator's manual
					X		*Clean Fuel Cup	
					X		*Replace engine air filter	See engine operator's manual
					X		Clean and Adjust Spark Plug	See engine operator's manual
						X	Replace Spark Plug	See engine operator's manual

* Perform these maintenance procedures more frequently under extreme dusty or dirty conditions.

** Use Unleaded Extreme Pressure Lithium Grease with NLGI #2 Grade

Section 5

5.2 ENGINE OIL

A. CHECKING ENGINE CRANKCASE OIL LEVEL

The engine oil level should be checked after every 8 hours of operation or daily as instructed in the Engine Operator's Manual furnished with this truck loader.

B. CHANGING ENGINE CRANKCASE OIL

After the first 20 hours of operation, change the engine crankcase oil and replace the oil filter. Thereafter, change the engine crankcase oil after every 100 hours of operation or bi-weekly, whichever occurs first. Refer to the Engine Operator's Manual furnished with this truck loader for instructions.

5.3 ENGINE FUEL SYSTEM



To avoid injury from burns, allow the engine to cool before removing the fuel tank cap and refueling.

A. FILLING THE FUEL TANK

Fill the fuel tank at the beginning of each operating day. Fill to approximately 1" below the top of the fuel tank (approximately 8-1/2 gallons indicating Full (F) on the fuel gauge) at the beginning of each operating day. Do not overfill. Use clean, fresh unleaded gasoline with a minimum octane rating of 87 and a maximum of 10% Ethanol.

DO NOT use E85 Fuel. Using E85 Fuel will cause severe damage to the engine.

To avoid personal injury or property damage, use extreme care in handling gasoline. Gasoline is extremely flammable and the vapors are explosive.

1. Extinguish all cigarettes, cigars, pipes and other sources of ignition.
2. Use only an approved gasoline container.
3. Never remove the gas cap or add fuel with the engine running. Allow the engine to completely cool before fueling.

4. Never fuel the machine indoors or in an enclosed trailer.
5. Never store the machine or fuel container where there is an open flame, spark or pilot light such as on a water heater or other appliances.
6. Never fill containers inside a vehicle or on a truck or trailer bed with a plastic liner. Always place containers on the ground away from your vehicle before filling.
7. Keep the nozzle in contact with the rim of fuel tank or container opening at all times until fueling is complete. Do not use a nozzle lock-open device.
8. If fuel is spilled on clothing, change clothing immediately and wash affected skin.
9. Replace gas cap and tighten securely.

5.4 ENGINE AIR CLEANER

A. CLEANING AND/OR REPLACING AIR CLEANER ELEMENT

For any air cleaner, the operating environment dictates the air cleaner service periods. Inspect and clean the air cleaner element after every 50 hours of operation or monthly, whichever occurs first and replace the element if required or every 200 hours. Refer to the Engine Operator's Manual furnished with this truck loader for instructions.

- NOTE -

In extremely dusty conditions it may be necessary to check the element once or twice daily to prevent engine damage.

5.5 IMPELLER DRIVE BELT ADJUSTMENT

WARNING

Before removing any guards, shut the engine off and remove the ignition key. Wait for all moving parts to come to a complete stop before beginning work.

1. Remove the belt cover.
2. Check the belt tension by using a belt tension gauge. The belt should move 1/2" with 14 pounds of pressure applied.
3. To adjust the impeller drive belt tension, loosen the four engine mounting bolts. See Figure 5-1.

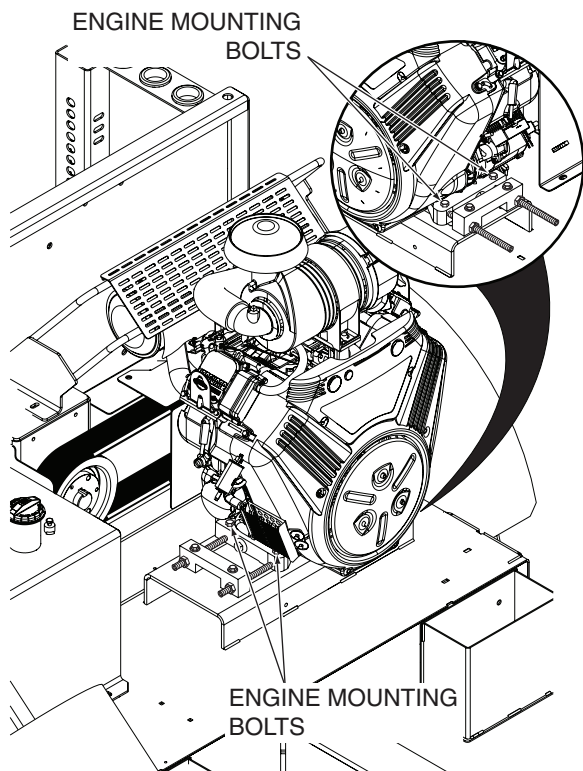

Figure 5-1. Impeller Drive Belt Tension

4. Loosen the jam nuts on all four adjustment studs. See Figure 5-2.
5. Back the two adjustment studs on the left side of the engine (closest to the wheel fender) off of the engine block enough to allow the engine to move.
6. Using a belt tension gauge, adjust the impeller drive belt tension by turning the adjustment studs on the

right side of the engine an equal amount of turns.

7. Adjust to achieve 1/2" with 14 pounds of pressure.
8. Turn the two left side adjustment studs in until they contact the side of the engine block. Tighten all four jam nuts on the adjustment studs.
9. Tighten the four engine mounting bolts and reinstall the belt cover.

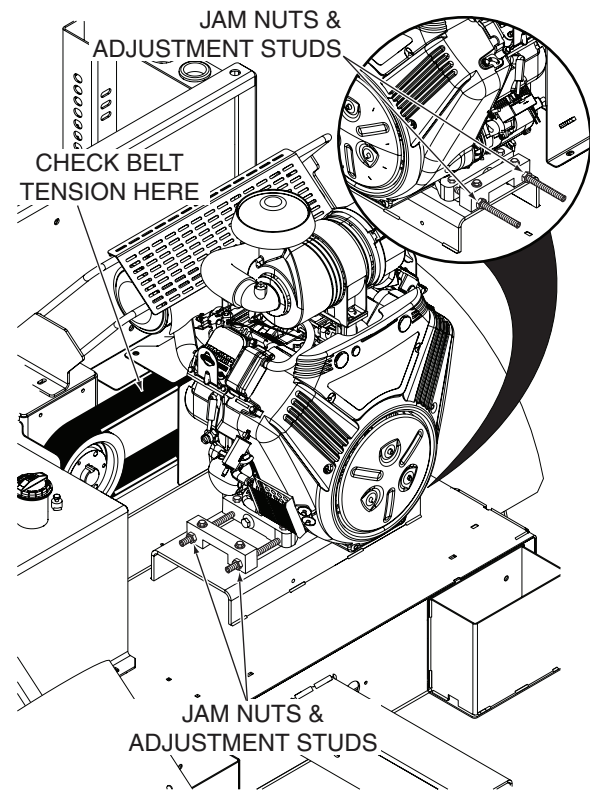

Figure 5-2. Impeller Drive Belt Tension

-NOTE-

Due to initial belt stretch and to prevent the belt from slipping, check this adjustment after the first 2 hours, 4 hours and 8 hours of operation.

Belt alignment and tension are important for proper performance of your Scag Truck Loader. If you experience frequent belt wear or breakage, see your authorized Scag service center for belt adjustment.

Section 5

5.6 IMPELLER SHAFT BEARINGS

WARNING

Before applying grease to the bearings, shut the engine off, remove the ignition key and allow the engine and exhaust to cool.

1. Apply grease to the two bearing carrier grease fittings located on the left side of the machine every 50 hours or weekly, whichever comes first, of operation. See Figure 5-3.

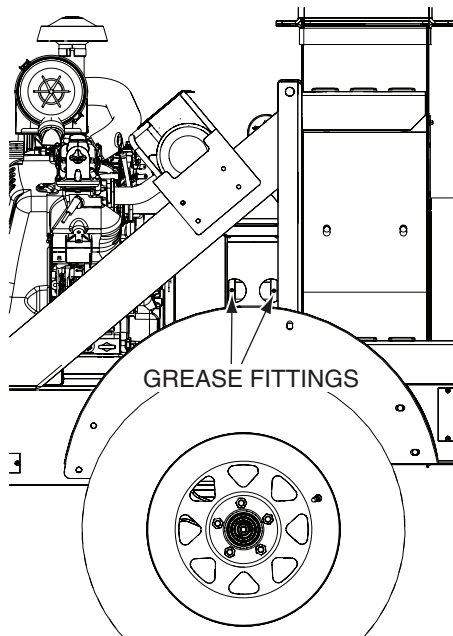

Figure 5-3. Impeller Shaft Grease Fittings

5.7 WHEELS & TIRES

Check the condition of wheel assemblies after 8 hours of operation or daily.

5.8 TRAILER LIGHTS

Check the trailer lights for proper operation every day before operation. Replace any defective component before operating.

ILLUSTRATED PARTS LIST

6.1 SCAG APPROVED ATTACHMENTS AND ACCESSORIES.

Attachments and accessories manufactured by companies other than Scag Power Equipment are not approved for use on this machine.

Scag Power Equipment approved attachments and accessories:

- Truck Loader Light Kit (p/n 9602)
- TLB Brake Kit (p/n 9606)

NOTES

INTAKE AND DISCHARGE ASSEMBLY

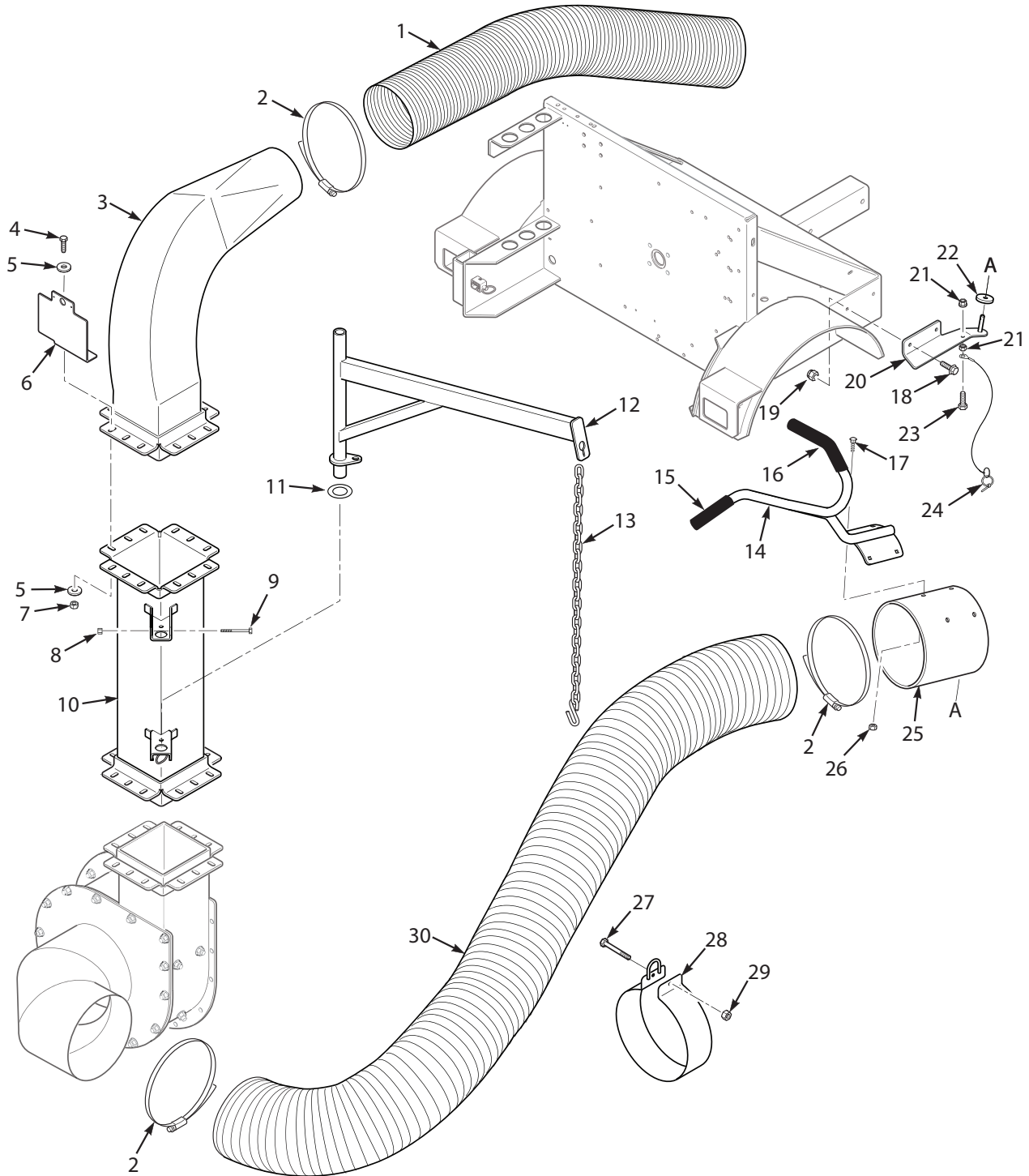

INTAKE AND DISCHARGE ASSEMBLY

Ref. No.	Part No.	Description
1	48135-58	Hose, Clear Poly 12" x 84"
2	486044-01	Strap, Ratchet- 66 x 1"
3	452529	Elbow, Exhaust - TLB25
4	04001-71	Bolt, Hex Head 1/2-13 x 1-1/2"
5	04040-13	Flatwasher, 1/2-.562 x 1.375 x .109
6	426327	Bracket, License Plate
7	04021-07	Nut, Elastic Stop 1/2-13
8	04021-08	Nut, Elastic Stop 1/4-20
9	04001-203	Bolt, Hex Head 1/4-20 x 4"
10	462633	Stack Assembly w/Decals
11	484947	Disk, Anti-Friction
12	452517	Boom Weldment
13	484894	Chain w/2-Hooks
14	462612	Handle w/Grips
15	485075	Grip, Handle 1-1/4" x 6"
16	485076	Grip, Handle 1-1/4" x 20"
17	04003-23	Bolt, Carriage 3/8-16 x 1"
18	04017-26	Bolt, Serrated Flange 3/8-16 x 3/4"
19	04019-04	Nut, Serrated Flange 3/8-16
20	452536	Hose Holder Weldment
21	04019-03	Nut, 5/16-18
22	485050	Washer, Rubber
23	04001-11	Bolt, Hex Head 5/16-18 x 1-1/2"
24	485062	Quick Pin Assembly w/Lanyard
25	462641	Nozzle w/Decal
26	04021-09	Nut, Elastic Stop 3/8-16
27	04001-49	Bolt, Hex Head 5/16-18 x 3"
28	452540	Band, Hose Support - 16"
29	04021-10	Nut, Elastic Stop 5/16-18
30	48135-29	Hose, 16" x 84" - .045 P.U. w/Wire

IMPELLER HOUSING ASSEMBLY

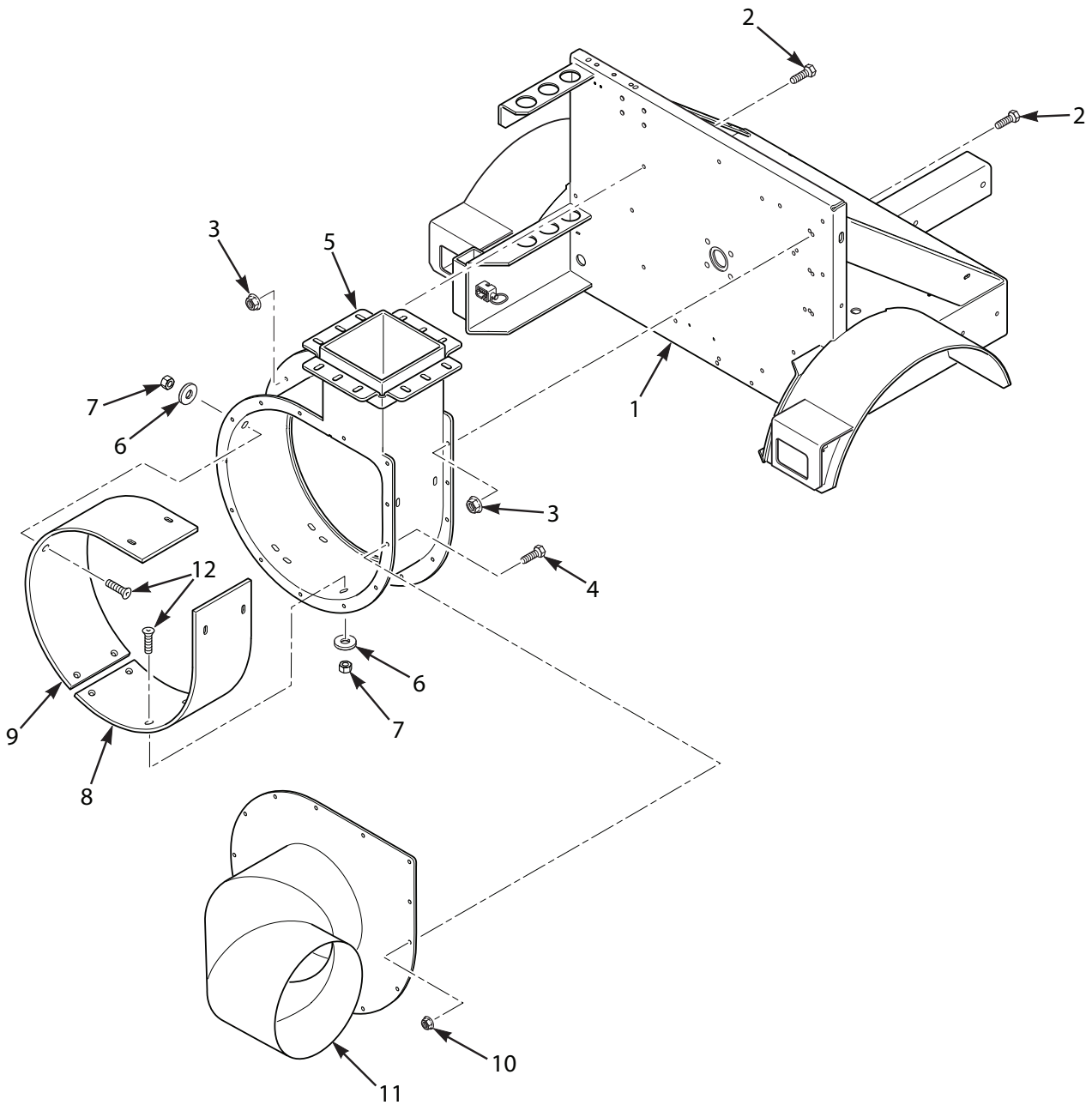

IMPELLER HOUSING ASSEMBLY

Ref. No.	Part No.	Description
1	462656	Base and Frame w/Decals
2	04017-53	Bolt, Hex Head 7/16-14 x 3/4"
3	04019-05	Nut, Serrated Flange 7/16-14
4	04017-26	Bolt, Serrated Flange 3/8-16 x 3/4"
5	462709	Impeller Housing Assembly- TLB25 (incl. # 6, 7, 8, 9, 12)
6	04040-13	Flatwasher, 1/2-.561 x 1.375 x .109
7	04021-07	Nut, Elastic Stop 1/2-13
8	426237	Wear Band, Long - TL25
9	426236	Wear Band, Short - TL25
10	04019-04	Nut, Serrated Flange 3/8-16
11	452492	Intake Elbow, TLB25
12	04014-05	Capscrew, 1/2-13 x 1-1/2" FHHS

IMPELLER DRIVE ASSEMBLY

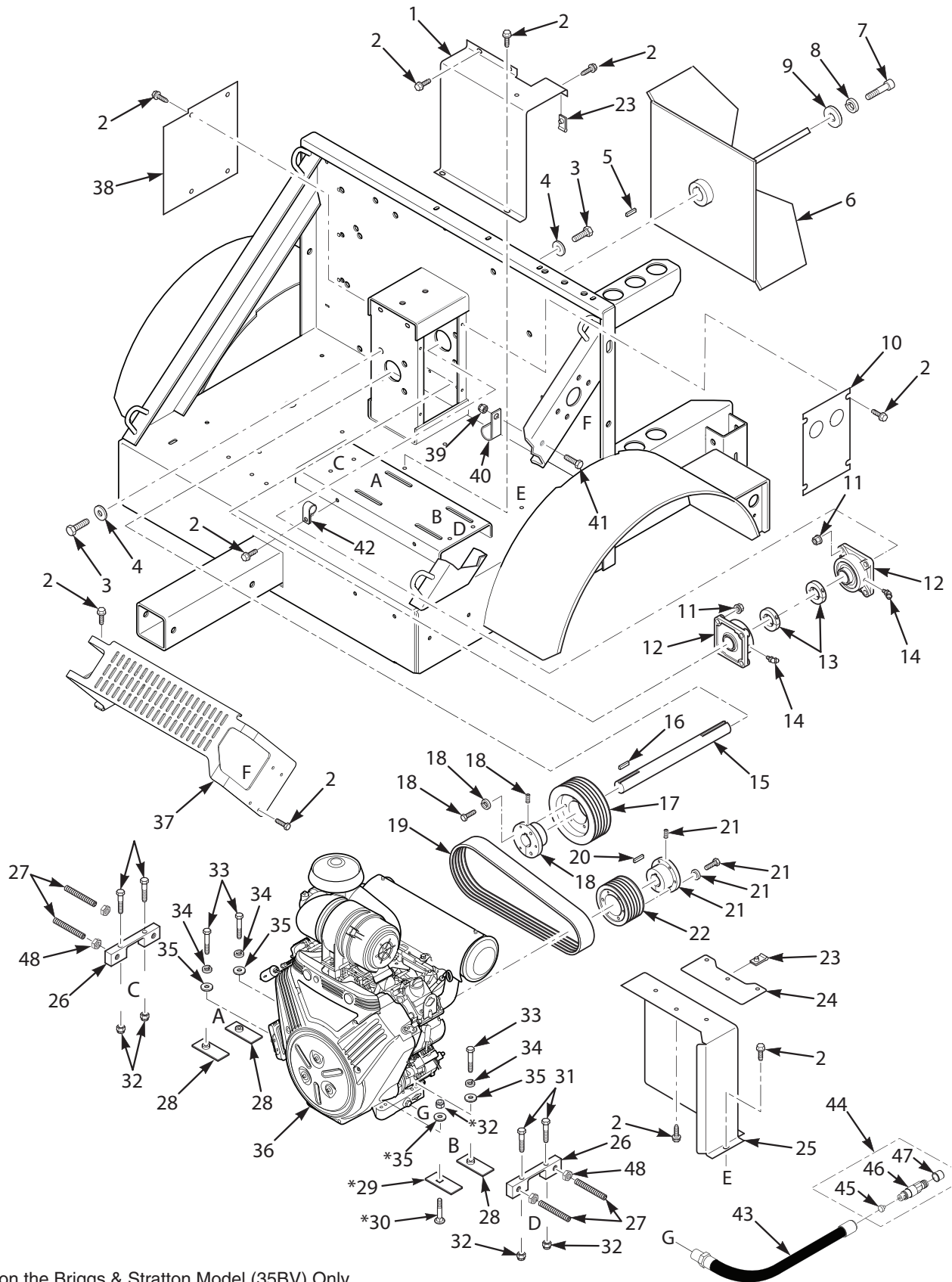

*Used on the Briggs & Stratton Model (35BV) Only

IMPELLER DRIVE ASSEMBLY

Ref. No.	Part No.	Description
1	426403	Belt Cover, Front
2	04011-12	Screw, 5/16-18 x 3/4" HD Shakeproof
3	04001-183	Bolt, Hex Head 1/2-13 x 1-3/4"
4	04040-13	Flatwasher, 1/2-.562 x 1.375 x .109
5	04063-33	Key, 3/8 x 3/8 x 4-1/2"
6	452445	Impeller, STL 4 Blade - 24-3/4" OD
7	04015-23	SHCS, 5/8-18 x 2-1/2"
8	04030-07	Lockwasher, 5/8"
9	04043-06	Flatwasher, 5/8-.688 x 1.75 x .134 HD
10	426405	Belt Cover, LH - Gas
11	04021-07	Nut, Elastic Stop 1/2-13
12	484909	Bearing, Flange Mount
13	485096	Collar. 2 pc 1-7/16
14	48114-07	Grease Fitting, 45 Degree 1/4-28 x .813
15	43943	Shaft, Impeller - TLB25
16	04063-34	Key, 3/8 x 3/8 x 2-1/4"
17	484995	Pulley, Sheave 3v6.9 x 5 SK
18	484993	Bushing, Taper - SK 1-7/16" (incl. hardware)
19	484800	Belt, R3V x 450-5
20	04063-22	Key, 3/8 x 3/8 x 1-1/4"
21	484996	Hub, Taper - SDS 1-7/16 (incl. hardware)
22	484994	Pulley, Sheave 3v6.9 x 5 SK
23	04110-02	U-Nut, 5/16-18
24	426407	Belt Guard, Engine
25	426404	Belt Guard, Rear
26	485098	Block, Engine Adjusting
27	04012-13	Set Screw, 1/2-13 x 4"
28	452534	Nut Plate Weldment - Briggs (x3)
	452535	Nut Plate Weldment - Kohler (x4)
29	426391	Nut Plate - Briggs (x1)
30	04003-44	Bolt, Carriage 5/16-18 x 5/16-18 x 2-1/4"
31	04001-39	Bolt, Hex Head 5/16-18 x 2-1/4"
32	04021-10	Nut, Elastic Stop 5/16-18
33	04001-39	Bolt, Hex Head 5/16-18 x 2-1/4" - Briggs (x3)
	04001-45	Bolt, Hex Head 3/8-16 x 2" - Kohler (x4)
34	04030-03	Lockwasher, 5/16" - Briggs (x3)
	04030-04	Lockwasher, 3/8" - Kohler (x4)
35	04040-15	Flatwasher, 5/16-.375 x .875 x .083
	04041-07	Flatwasher, 3/8-.391 x .938 x .105
36	484959	Engine, Briggs Vanguard 35BV (not available through Scag Power Equipment)
	484960	Engine, Kohler Command 37CH (not available through Scag Power Equipment)
37	426457	Muffler Guard (Briggs BV)
	452530	Muffler Guard Weldment (Kohler CH)
38	426401	Belt Guard, RH - Gas
39	04021-09	Nut, Elastic Stop 3/8-16
40	48030-21	Clamp, Cable J-Clip
41	04001-18	Bolt, Hex Head 3/8-16 x 3/4"
42	48030-11	Clamp, Cable 5/8 Double
43	484599	Hose, Oil Drain - Briggs (incl. # 45, 46, 47,)
	484596	Hose, Oil Drain - Kohler (incl. # 45, 46, 47,)
44	484593	Valve Assembly, Oil Drain
45	484586	Seal
46	48603-12	O-Ring
47	484585	Cap
48	04020-07	Nut, 1/2-13 UNC

TRAILER ASSEMBLY

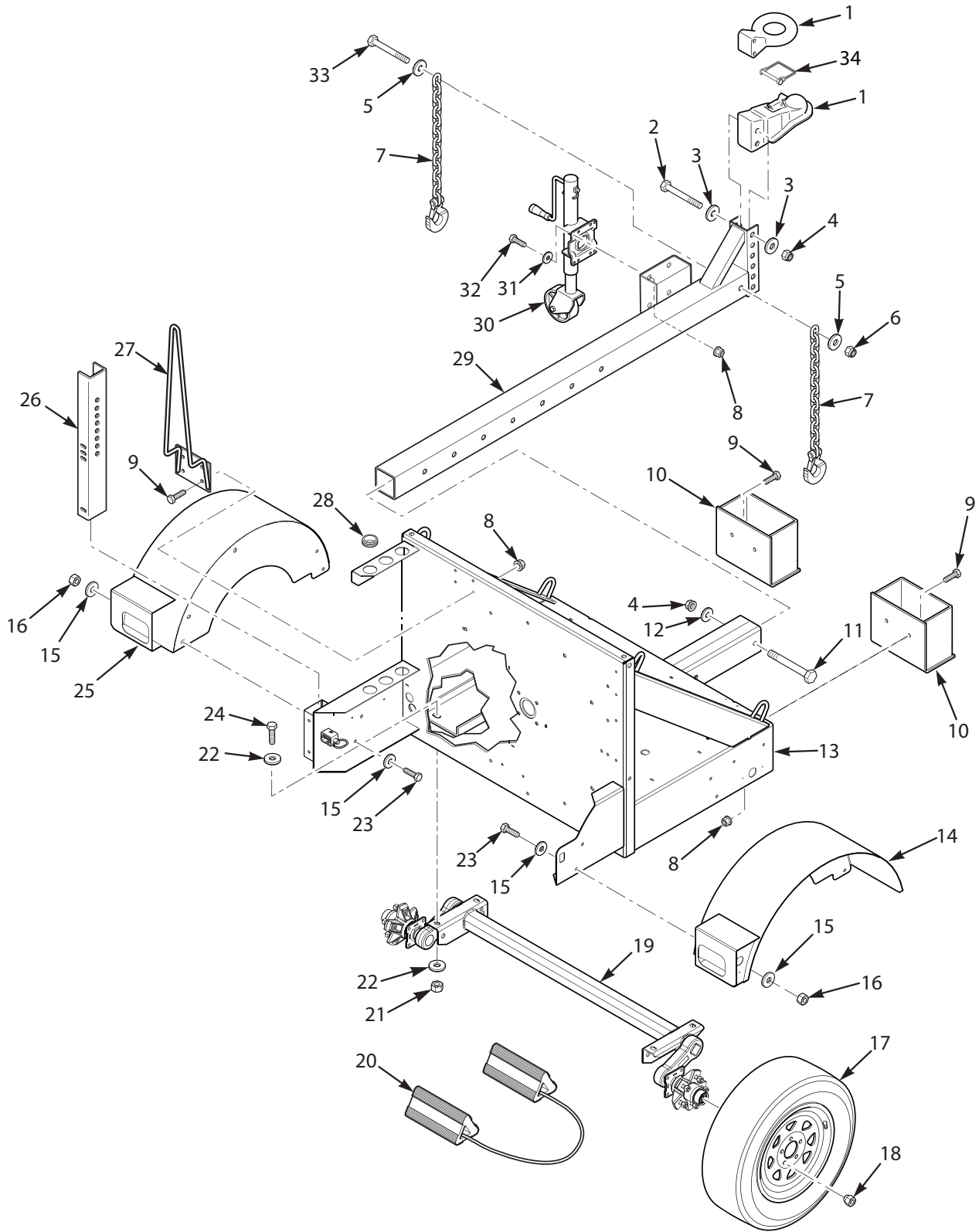

TRAILER ASSEMBLY

Ref. No.	Part No.	Description
1	485104	Ball Coupler, 2-5/16"
	485105	Pintle Ring, 3" (optional)
2	04001-204	Bolt, Hex Head 5/8-11 x 4-3/4" Grade 8
3	04043-09	Flatwasher, 5/8-.656 x 1.312 x 0.95 HD
4	04021-23	Nut, Elastic Stop 5/8-11
5	04040-13	Flatwasher, 1/2-.562 x 1.375 x .109
6	04113-04	Nut, Lock, Elastic Stop, M12 x 1 3/4
7	485064	Safety Chain
8	04019-04	Nut, Serrated Flange 3/8-16
9	04017-26	Bolt, Serrated Flange 3/8-16 x 3/4"
10	452519	Chock Box
11	04001-119	Bolt, Hex Head 5/8-11 x 5-1/2"
12	04040-10	Flatwasher, 5/8-.688 x 1.750 x .134
13	462656	Base and Frame w/Decals
14	452545	Fender Weldment, RH
15	04040-11	Flatwasher, 7/16-.500 x 1.250 x .083
16	04021-11	Nut, Elastic Stop 7/16-14
17	484948	Wheel Assembly, 205/75D15 - 6 Ply
	485091	Rim, 15 x 5 - 5 Lug
	485092	Tire, 205/75D15 - 6 Ply
18	04028-02	Lug Nut
19	485081	Axle, 3500 LBS. (incl. #18)
20	485103	Wheel Chocks w/Rope
21	04021-13	Nut, Elastic Stop 5/8-11
22	04043-06	Flatwasher, 5/8-.688 x 1.75 x .134 HD
23	04001-28	Bolt, Hex Head 7/16-14 x 1-1/4"
24	04001-131	Bolt, Hex Head 5/8-11 x 1-3/4"
25	452544	Fender Weldment, LH
26	426208	Support Channel
27	485109	Holder, Traffic Cone
	485079	Traffic Cone (not shown)
28	485080	Grommet, Rubber
29	492357	Drawbar Assembly w/Decal, TLB25 (INCL. 1,2, 3,4,5,6,7,8,30,31,32,33,34,Decal-485126)
30	484849	Jack, Single Wheel
31	04041-07	Flatwasher, 3/8-.391 x .938 x .105
32	04001-19	Bolt, Hex Head 3/8-16 x 1"
33	04002-29	Bolt, M12-1-3/4 x 140
34	485110	Pin, Snapper

FUEL AND ELECTRICAL SYSTEM

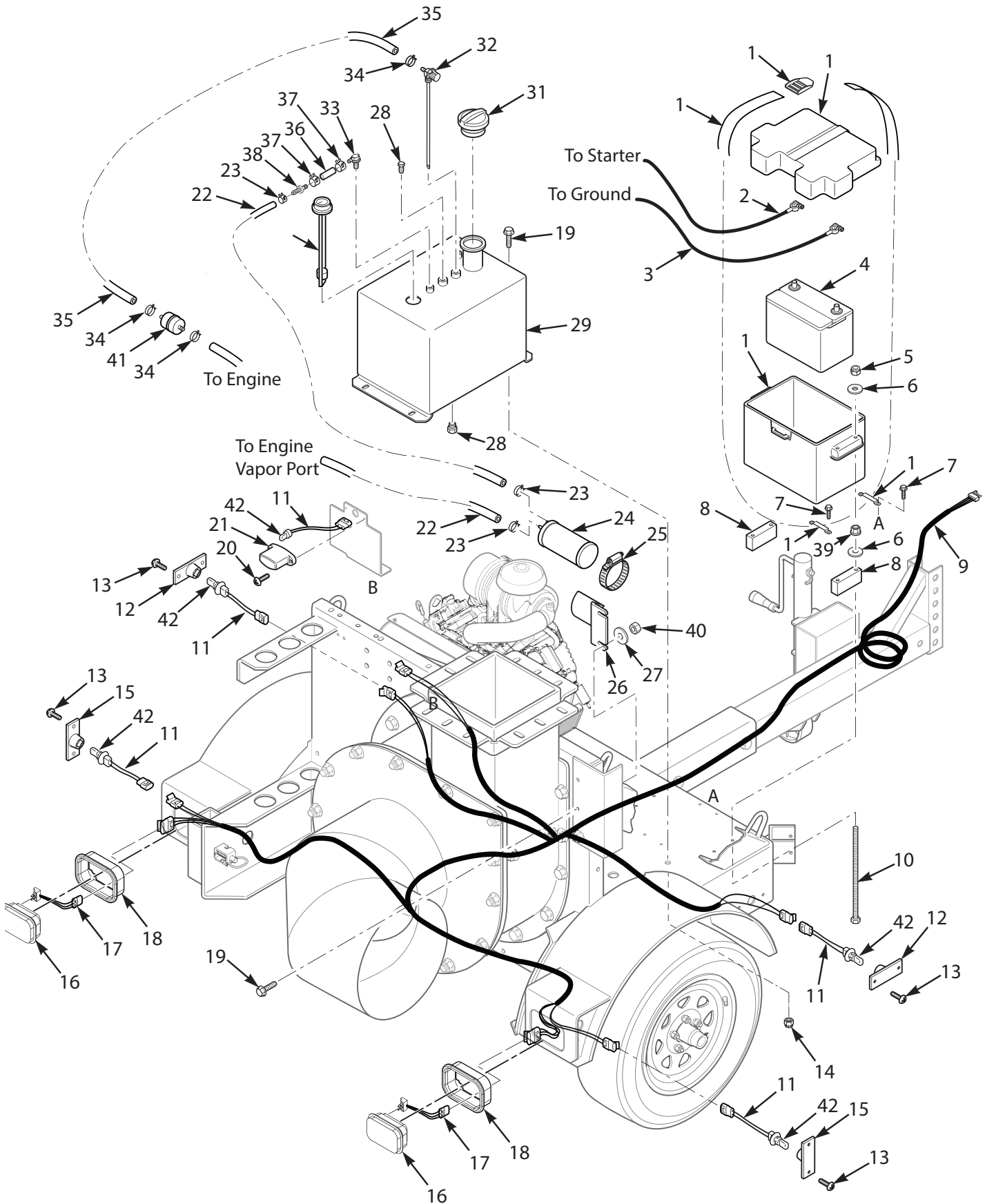

Section 6

FUEL AND ELECTRICAL SYSTEM

Ref. No.	Part No.	Description
1	484989	Battery Box, GRP24
2	481176-14	Battery Cable, Red 50" w/Conduit
3	481176-12	Battery Cable, Black 32"
4	482283	Battery (not available through Scag Power Equipment)
5	04021-08	Nut, Elastic Stop 1/4-20
6	04040-14	Flatwasher, 1/4-.312 x .750 x .065
7	04011-11	Screw, #10-32 x .56 HWHD Shakeproof
8	485053	Spacer, Battery Bob (x6)
9	485043	Wire Harness, TL
10	04003-30	Bolt, Carriage 1/4-20 x 7-1/2"
11	485112	Pigtail, Side Marker Light
12	485041	Side Marker Light, Yellow (does not include #42)
13	04011-23	Screw, #8-18 x 3/4" Self Tap
14	04019-04	Nut, Serrated Flange 3/8-16
15	485040	Side Marker Light, Red (does not include #42)
16	485039	Stop / Turn / Tail Light
17	485111	Pigtail, Tail Light
18	485072	Grommet, Tail Light
19	04017-26	Bolt, Hex Head 3/8-16 x 3/4"
20	04011-06	Screw, #10-30 x 3/4" Self Tap
21	485077	Light, License Plate (includes #42)
22	484345	Hose, Vapor Recovery 3/16" (order by inch)
23	48059-02	Clamp, Vapor Recovery 3/16"
24	484342	Carbon Cannister, 550cc
25	48136-17	Clamp, 3-1/2" Max Dia.
26	452225	Cannister Mounting Bracket
27	04040-15	Flatwasher, 5/16-.375 x .875 x .083
28	481652-02	Plug, Pipe 1/4 NPT
29	492355	Fuel Tank Assembly (incl. # 28, 30, 31, 32, 33)
30	484323	Fuel Gauge Assembly (incl. seal)
	484242	Seal, Fuel Gauge
31	485083	Fuel Cap, Steel Tank
32	485100	Fuel Pick Up Tube
33	481301-02	Elbow, 90 Degree 1/4 NPT
34	48059-01	Clamp, Fuel Hose 1/4"
35	483617	Hose, Fuel Line 1/4" (order by inch)
36	484347	Hose, Vapor Recovery 1/4" (order by inch)
37	48059-02	Clamp, Fuel Hose 7/32" OD
38	484343-01	Menderm 1/4 x 3/16 w/.02 Hole
39	04019-02	Nut, Serrated Flange 1/4-20
40	04021-10	Nut, Elastic Stop 1/4-20
41	*	Fuel Filter (order through engine manufacturer)
42	485086	Light Bulb, 194

TLB25 - TRUCK LOADER DECALS

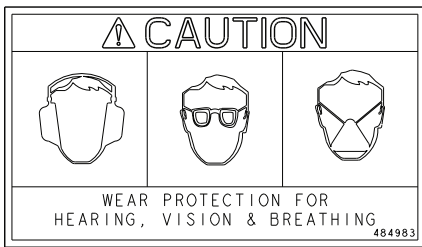

484983



485139

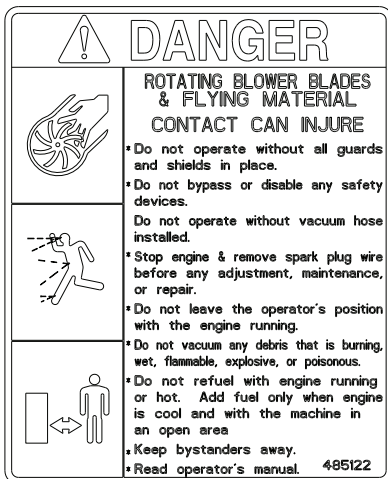

485122



483402

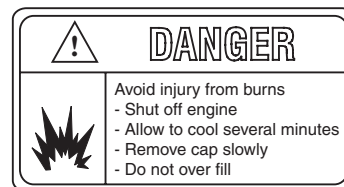

484281

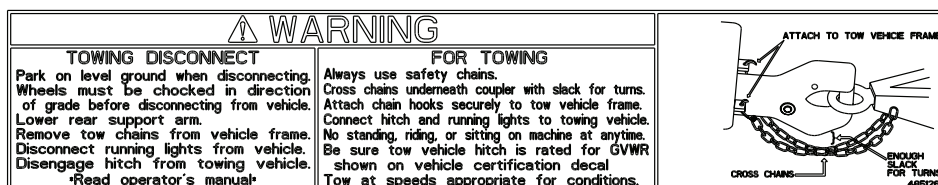

485126



486246

TLB25 - TRAILER LIGHT WIRING DIAGRAM

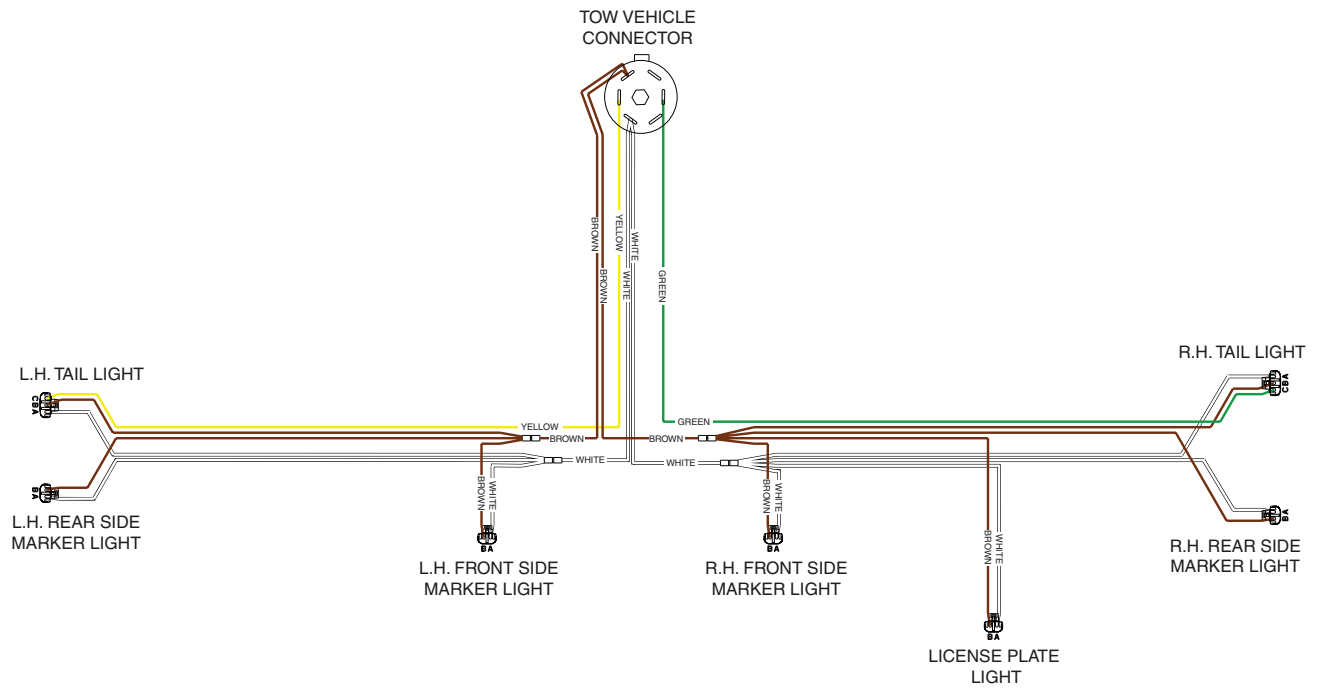

LIMITED WARRANTY - TRUCK LOADERS

Any part of the Truck Loader manufactured by Scag Power Equipment and found, in the reasonable judgment of Scag Power Equipment, to be defective in materials or workmanship, will be repaired or replaced by an Authorized Scag Service Dealer without charge for parts and labor during the periods specified below. This warranty is limited to the original purchaser and is not transferable. Proof of purchase will be required by the dealer to substantiate any warranty claims. All warranty work must be performed by an Authorized Scag Power Equipment Service Dealer.

This warranty is limited to the following specified periods from the date of the original retail purchase for defects in materials or workmanship:

- Wear items including impellers, wear liners, nose cones, hoses, bearings and tires are not included in this warranty.
- Frame, blower housing and structural components are warranted for two (2) year (parts and labor) for commercial and non-commercial use.
- Engines and electric starters are covered by the engine manufacturer's warranty period. Therefore, there are no warranties made, expressed or implied, for engines by Scag Power Equipment.
- Batteries are covered for ninety (90) days.
- Any Scag product used for rental purposes is covered by a 90 day warranty.

The Scag Truck Loader, including any defective part must be returned to an Authorized Scag Power Equipment Service Dealer within the warranty period. The expense of delivering the truck loader to the dealer for warranty work and the expense of returning it to the owner after repair will be paid for by the owner. Scag Power Equipment's responsibility is limited to making the required repairs and no claim of breach of warranty shall be cause for cancellation or rescission of the contract of sale of any Scag product. "Non-Commercial" use is defined as a single property owner, where the single property is the residence of the owner of the Scag product. If the truck loader is used on more than the owners single property, it is deemed commercial use and the "non-commercial" warranty does not apply. Scag Power Equipment reserves the right to deny and / or void the non-commercial warranty if it believes it to be in commercial use.

This warranty does not cover any product that has been subject to misuse, neglect, negligence, or accident, or that has been operated in any way contrary to the operating instructions as specified in the Operator's Manual. The warranty does not apply to any damage to any truck loader that is the result of improper maintenance, or to any truck loader or parts that have not been assembled or installed as specified in the Operator's Manual and Assembly Manual. The warranty does not cover any truck loader that has been altered or modified, changing performance or durability. In addition, the warranty does not extend to repairs made necessary by normal wear, to items subject to abrasion wear, or by the use of parts or accessories which, in the reasonable judgment of Scag Power Equipment, are either incompatible with the Scag Truck Loader or adversely affect its operation, performance or durability.

Scag Power Equipment reserves the right to change or improve the design of any product without assuming any obligation to modify any product previously manufactured. All other implied warranties for this truck loader are limited in duration to the two (2) year warranty for commercial and non-commercial use or ninety (90) days used for rental purpose. Accordingly, any such implied warranties including merchantability, fitness for a particular purpose, or otherwise, are disclaimed in their entirety after the expiration of the appropriate warranty period. Scag's obligation under this warranty is strictly and exclusively limited to the repair or replacement of defective parts and Scag Power Equipment does not assume or authorize anyone to assume for them any other obligation. Some states do not allow limitations on how long an implied warranty lasts, so the above limitation may not apply to you.

Scag Power Equipment assumes no responsibility for incidental, consequential or other damages including, but not limited to, expense for gasoline, expense of delivering the truck loader to an Authorized Scag Power Equipment Service Dealer and expense of returning it to the owner, mechanic's travel time, telephone or telegram charges, rental of a like product during the time warranty repairs are being performed, travel, loss or damage to personal property, loss of revenue, loss of use of the truck loader, loss of time or inconvenience. Some states do not allow the exclusion or limitation of incidental or consequential damages, so the above limitation or exclusion may not apply to you. This warranty gives you specific legal rights, and you may also have other rights which vary from state to state.