

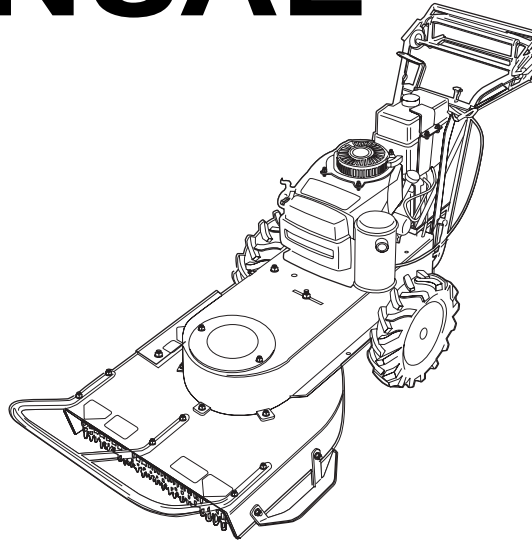

GIANT-VAC



OPERATOR'S MANUAL



Field and Brush Mower

Mfg. No.	Model No.	Description
7085922	FB13250BS	13 hp Briggs, Hydro-Drive
7085923	GM2515KAW	15 hp Kawasaki, Hydro-Drive
7085924	GM2513H	13 hp Honda, Hydro-Drive

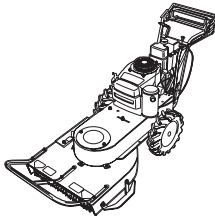

Table of Contents

Identification Numbers	1	Troubleshooting, Adjustment and Service	14
Safety Rules & Information	2	Chart	14
Safety Decals	4	Travel Control Adjustment	16
Features & Controls	6	Blade Clutch Adjustment.....	17
Control Functions	6	Blade Brake Adjustment	18
Operating the Mower	7	Mower Belt Adjustment	18
Starting the Engine	7	Traction Drive Belt Adjustment	19
Engaging the Transmission	7	Mower Belt Replacement.....	20
Engaging/Disengaging the Cutting Blade	9	Specifications	21
To Adjust Cutting Height	10	Parts & Accessories	21
Storage	10	Replacement Parts	21
Regular Maintenance	11	Maintenance Items.....	21
Lubrication	11	Technical Manuals	21
Tire Pressure	12		
Battery Service.....	12		
Servicing the Mower Blades	13		

NOTE: In this manual, “left” and “right” are referred to as seen from the operating position.

Identification Numbers

When contacting your authorized dealer for replacement parts, service, or information you **MUST** have these numbers.

Record your model name/number, manufacturer's identification numbers, and engine serial numbers in the space provided for easy access. This information is contained in the Machine Identification Label attached to the machine.

NOTE: For location of engine identification numbers, refer to the engine owner's manual.

<div style="border: 1px solid black; border-radius: 15px; padding: 5px; margin: 0 auto; width: 80%;"> <p>Model _____</p> <p>Serial _____</p> </div>

Figure 1 - Serial Number Tag

PRODUCT REFERENCE DATA	
Model Description Name/Number	
Unit MFG Number	Unit SERIAL Number
Mower Deck MFG Number	Mower Deck SERIAL Number
Dealer Name	Date Purchased
ENGINE REFERENCE DATA	
Engine Make	Engine Model
Engine Type/Spec	Engine Code/Serial Number



Safety Rules & Information



Read these safety rules and follow them closely. Failure to obey these rules could result in loss of control of unit, severe personal injury or death to you, or bystanders, or damage to property or equipment. **This mowing deck is capable of amputating hands and feet and throwing objects.** The triangle in text signifies important cautions or warnings which must be followed.

SAFE OPERATION PRACTICES FOR WALK-BEHIND MOWERS

This cutting machine is capable of amputating hands and feet and throwing objects. Failure to observe the following safety instructions could result in serious injury or death.

GENERAL OPERATION

- Read, understand, and follow all instructions on the machine and in the manual(s). Be thoroughly familiar with the controls and the proper use of the mower before starting.
- Do not put hand or feet near or under rotating parts. Keep clear of the discharge opening at all times.
- Only allow responsible individuals, who are familiar with the instructions, to operate the mower.
- Clear the area of objects such as rocks, toys, wire, bones, sticks etc., which could be picked up and thrown by the blade.
- Be sure the area is clear of other people before mowing. Stop mower if anyone enters the area.
- Do not operate the mower when barefoot or wearing open sandals. Always wear substantial foot wear.
- Do not pull mower backwards unless absolutely necessary. Look down and behind before and while moving backwards.
- Do not operate the mower without proper guards, plates, grass catcher or other safety protective devices in place.
- See manufacturer's instructions for proper operation and installation of accessories. Use only accessories approved by the manufacturer.
- Stop the blade(s) when crossing gravel drives, walks, or roads.
- Shut off the engine (motor) whenever you leave the equipment, before cleaning the mower or unclogging the chute.
- Shut the engine (motor) off and wait until the blade comes to a complete stop before removing grass catcher.
- Mow only in daylight or good artificial light.
- Do not operate the mower while under the influence of alcohol or drugs.
- Never operate mower in wet grass. Always be sure of your footing; keep a firm hold on the handle and walk; never run.
- Disengage the self-propelled mechanism or drive clutch on mowers so equipped before starting the engine (motor).
- If the equipment should start to vibrate abnormally, stop the engine (motor) and check immediately for the cause. Vibration is generally a warning of trouble.
- Always wear safety goggles or safety glasses with side shields when operating mower.

SLOPE OPERATION

WARNING

Never operate on slopes greater than 17.6 percent (10°) which is a rise of 3-1/2 feet (106 cm) vertically in 20 feet (607 cm) horizontally.

Select slow ground speed before driving onto slope. In addition to front and rear weights, use extra caution when operating on slopes with rear-mounted grass catcher.

Mow across the slope, never up and down, use caution when changing directions and **DO NOT START OR STOP ON SLOPE.**

Slopes are a major factor related to slip and fall accidents, which can result in severe injury. All slopes require extra caution. If you feel uneasy on a slope, do not mow it.

Do

- Mow across the face of slopes; never up and down. Exercise extreme caution when changing direction on slopes.
- Remove obstacles such as rocks, tree limbs, etc.
- Watch for holes, ruts, or bumps. Tall grass can hide obstacles.

Do Not

- *Do not* mow near drop-offs, ditches, or embankments. The operator could lose footing or balance.
- *Do not* mow excessively steep slopes.
- *Do not* mow on wet grass. Reduced footing could cause slipping.

CHILDREN

Tragic accidents can occur if the operator is not alert to the presence of children. Children are often attracted to the unit and the mowing activity. *Never* assume that children will remain where you last saw them.

- Keep children out of the mowing area and under the watchful care of another responsible adult.
- Be alert and turn mower off if children enter the area.
- Before and while moving backwards, look behind and *down* for small children.
- Never allow children to operate the mower.
- Use extra care when approaching blind corners, shrubs, trees, or other objects that may obscure vision.

SERVICE

- Use extra care when handling gasoline and other fuels. They are flammable and vapors are explosive.
 - a) Use only an approved container.
 - b) Never remove fuel cap or add fuel with the engine running. Allow engine to cool before refueling. Do not smoke.
 - c) Never refuel the machine indoors.
 - d) Never store the machine or fuel container inside where there is an open flame, such as a water heater.
 - Never run an engine inside a closed area.
 - Never make adjustments or repairs with the engine (motor) running. Disconnect the spark plug wire, and keep the wire away from the plug to prevent accidental starting.
 - Keep all nuts and bolts, especially blade attachment bolts, tight and keep equipment in good condition.
 - Never tamper with safety devices. Check their proper operation regularly.
 - Keep mower free of grass, leaves, or other debris build-up. Clean up oil or fuel spillage. Allow mower to cool before storing.
 - Stop and inspect the equipment if you strike an object. Repair, if necessary, before restarting.
 - Never attempt to make wheel height adjustments while the engine (motor) is running.
 - Always disconnect electric mowers (live operated) before cleaning, repairing, or adjusting.
 - Grass catcher components are subject to wear, damage, and deterioration, which could expose moving parts or allow objects to be thrown. Frequently check components and replace with manufacturer's recommended parts, when necessary.
 - Mower blades are sharp and can cut. Wrap the blade(s) or wear gloves, and use extra caution when servicing them.
 - Do not change the engine governor setting or over-speed the engine.
- * Asterisked items do not apply to electric mowers.

EMISSIONS

- Engine exhaust from this product contains chemicals known, in certain quantities, to cause cancer, birth defects, or other reproductive harm.
- Look for the relevant Emissions Durability Period and Air Index information on the engine emissions label.

Safety Rules & Information

SERVICE AND MAINTENANCE

- Use extra care in handling gasoline and other fuels. They are flammable and vapors are explosive.
 - a) Use only an approved container.
 - b) Never remove gas cap or add fuel with the engine running. Allow engine to cool before refueling. Do not smoke.
 - c) Never refuel the unit indoors.
- If fuel is spilled, do not attempt to start the engine but move the machine away from the area of spillage and avoid creating any source of ignition until fuel vapors have dissipated.
- Replace all fuel tank caps and fuel container caps securely.
- Never fill containers inside a vehicle or on a truck bed with a plastic bed liner. Always place containers on the ground away from your vehicle before filling.
- Remove gas-powered equipment from the truck or trailer and refuel it on the ground. If this is not possible, then refuel such equipment on a trailer with a portable container, rather than from a gasoline dispenser nozzle.
- Keep nozzle in contact with the rim of the fuel tank or container opening at all times until fueling is complete. Do not use a nozzle lock-open device.
- If fuel is spilled on clothing, change clothing immediately.
- Maintain or replace safety and instruction labels as necessary.
- Never run a unit in an enclosed area.
- Keep nuts and bolts, especially blade attachment bolts, tight and keep equipment in good condition.
- Never tamper with safety devices. Check their proper operation regularly and make necessary repairs if they are not functioning properly.
- Keep unit free of grass, leaves, or other debris build-up. Clean up oil or fuel spillage.
- Stop and inspect the equipment if you strike an object. Repair, if necessary, before restarting.
- Never make adjustments or repairs with the engine running unless specified otherwise in the engine manufacturer's manual.
- Do not remove the fuel filter when the engine is hot as spilled gasoline may ignite. Do not spread fuel line clamps further than necessary. Ensure clamps grip hoses firmly over the filter after installation.
- Do not use gasoline containing METHANOL, gasohol containing more than 10% ETHANOL, gasoline additives, or white gas because engine/fuel system damage could result.
- Mower blades are sharp and can cut. Wrap the blade(s) or wear gloves, and use extra caution when servicing them.
- Check blade brake operation frequently. Adjust and service as required.
- Use only factory authorized replacement parts when making repairs.
- Always comply with factory specifications on all settings and adjustments.
- Only authorized service locations should be utilized for major service and repair requirements.
- Never attempt to make major repairs on this unit unless you have been properly trained. Improper service procedures can result in hazardous operation, equipment damage and voiding of manufacturer's warranty.
- Do not change engine governor settings or over-speed the engine. Operating the engine at excessive speed can increase the hazard of personal injury.
- Disengage drive attachments, stop the engine, remove the key, and disconnect the spark plug wire(s) before: clearing attachment blockages and chutes, performing service work, striking an object, or if the unit vibrates abnormally. After striking an object, inspect the machine for damage and make repairs before restarting and operating the equipment.

SAFETY DECALS

This unit has been designed and manufactured to provide you with the safety and reliability you would expect from an industry leader in outdoor power equipment manufacturing.

Although reading this manual and the safety instructions it contains will provide you with the necessary basic knowledge to operate this equipment safely and effectively, we have placed several safety labels on the unit to remind you of this important information while you are operating your unit.

All DANGER, WARNING, CAUTION and instructional messages on your mower should be carefully read and obeyed. Personal bodily injury can result when these instructions are not followed. The information is for your safety and it is important! All of the safety decals below are on your mower.

If any of these decals are lost or damaged, replace them at once. See your local dealer for replacements.

These labels are easily applied and will act as a constant visual reminder to you, and others who may use the equipment, to follow the safety instructions necessary for safe, effective operation.

Safety and Instructional Decals



Decal - Warning (7028490)

Important Safety Operating Instructions. Read and understand before operating machine

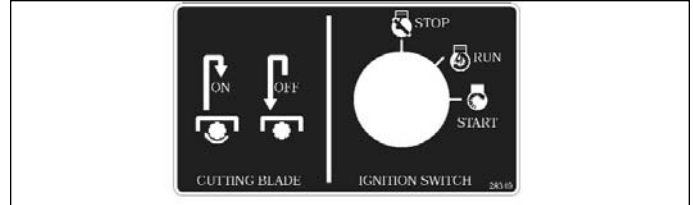

Decal - Blade Control, Engine Key Switch (7028349)
Models - All mowers



Decal - Traction Drive / Freewheel Lever (1725229)
Models - All mowers



Decal - Engine Throttle Control (7029167)
Models - All mowers



Decal - Caution - Open Belt Drive (707359)
Rotating blades and other parts can cause serious injury. Keep hands and feet away.



Decal - Danger: Dismemberment (7013010)

This mower deck can amputate limbs. Keep hands and feet away from blades.



Decal - Danger: Flying Objects (7073647)

This machine is capable of throwing objects and debris. Keep bystanders away.

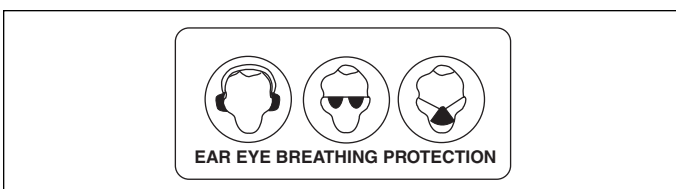

Decal - Personal Protection (7075893)

Make sure to wear Hearing, Eye and Breathing protection.



Decal - Speed Adjustn (1725230) Models - All mowers

Features & Controls

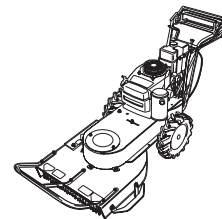

Please take a moment and familiarize yourself with the name, location, and function of these controls so that you will better understand the safety and operating instructions provided in this manual.

CONTROL FUNCTIONS

The information below briefly describes the function of individual controls. Starting, stopping, driving, and mowing require the combined use of several controls applied in specific sequences. To learn what combination and sequence of controls to use for various tasks see the OPERATION section.

Fuel Tank

To remove cap, turn counterclockwise (CCW). To open the fuel valve, located at the bottom of the tank, turn knob CCW.

PTO Engagement Lever

The PTO Engagement Lever engages and disengages the mower blade. To engage the mower blade push the lever forward to the fully engaged and locked position. To disengage the mower blade push the lever out of the locked position, slightly to the left and pull backwards to the disengaged position.

When the PTO engagement lever is in the Engaged position, the Engine Kill system is activated.

Engine Kill Bar

This control deactivates the engine kill system. With the PTO Engagement Lever in the Engaged position, the Engine Kill system will shut the engine off if the operators' hands leave the handle bar, releasing the Engine Kill Bar.

Traction Drive Engagement Bar

Two hand grips, Forward Travel and Reverse Travel, are within easy reach of the main handle bar. The traction drive engagement bar to the front of the main handle engages reverse travel. The traction drive engagement bar below the main handle engages forward travel.

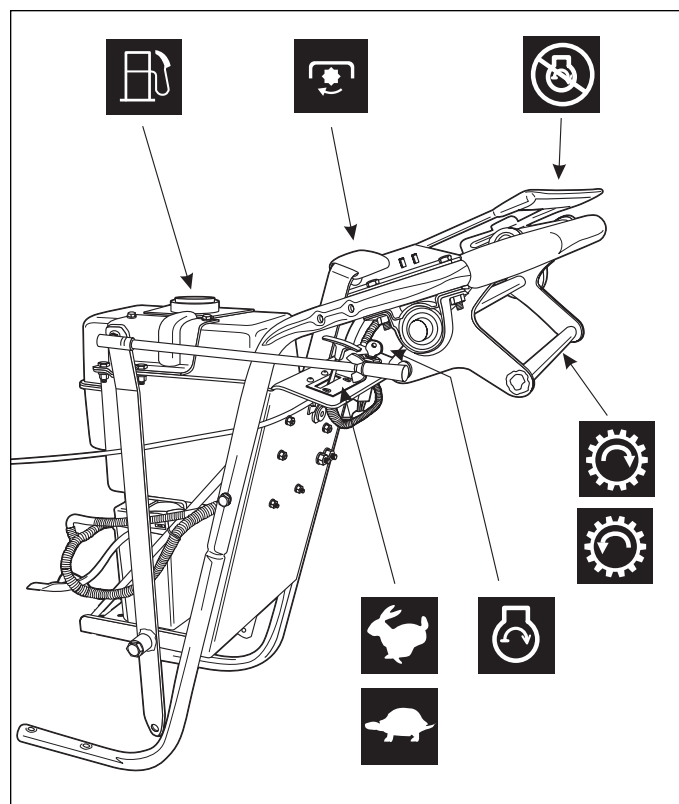

Figure 3. Brush Mower Controls

Engine On/Starter

Rotate this key switch to the ON position before pulling on the starter rope.

If the mower is equipped with the optional electric starting system, rotate the key past the ON position to engage the starter. When the engine starts, release the key.

Throttle Control

The throttle controls engine speed. Move the throttle to the right to increase engine speed, and to the left to lower engine speed. When mowing, always operate the engine at FULL throttle.

To set the choke for starting a cold engine, move the throttle lever past the FULL speed position. As soon as the engine starts, move the control to the FULL position.

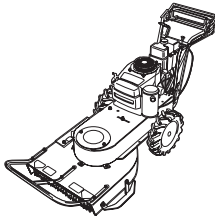

Operating the Mower

STARTING THE ENGINE

NOTE - The procedures outlined within this section are general guidelines, and are in no way meant to replace or supercede engine manufacturer's operating instructions. In order to obtain optimum performance from your engine, refer to your engine manual.

Before Starting Engine:

- Be sure that the unit is completely assembled, all fasteners are tightened securely, and all safety guards and components are in place.
- Be sure to check engine's oil and gasoline*. (See engine manual for recommended oil and gasoline specifications.) Never check the engine while it is running or while you are smoking. Check only when engine is cold.

*All machines are shipped without oil or gasoline unless otherwise noted.

To Start Engine:

Recoil Start -

- Open fuel valve, located at bottom of fuel tank by turning knob counterclockwise.
- Set throttle control past the "START" position (fully Right to the double lines) to engage choke.
- Turn key on dash panel to "RUN" position.
- Grasp recoil handle and pull cord briskly. (You may have to pull several times before engine starts. If engine fails to start within a reasonable number of attempts, discontinue and check engine manual for further instructions.)

NOTE: Be sure recoil cord retracts fully into recoil unit. A slack recoil cord can cause serious personal injury and/or damage to unit.

Electric Start - (Optional)

- Open fuel valve, located at bottom of fuel tank by turning knob counterclockwise.
- Set throttle control past the "START" position (fully Right to the double lines) to engage choke.
- Turn ignition key on dash panel past "RUN" position to "START" to engage starter. (If engine fails to start within a reasonable period of time - generally 2-3 attempts of 5-6 seconds cranking time each, discontinue and check engine manual for further instructions.)

To Shut Engine Down:

- Allow engine to idle for 2-3 minutes before shutting down.
- Set throttle control down to "SLOW" position.
- Turn key to "OFF" position.

NOTE: If you experience problems with your engine that cannot be satisfactorily resolved by following the instructions contained within the engine manual, contact your local engine dealer. All engine service, warranty or otherwise, is required to be performed by a manufacturer-authorized service center.

ENGAGING THE TRANSMISSION

Your Field & Brush mower is equipped with a rugged hydrostatic transmission. The mower can be operated at variable speeds in both forward and reverse directions. Please read the following instructions in order to acquaint yourself with the mowers controls for safe operation.

The traction drive system is engaged or disengaged through the Traction Drive control lever (Figure 4), located on the right side of the machine, when standing at the Operator's Controls.

- Engage the traction drive by moving the control lever to the DRIVE position. The brush mower can now be moved using the Traction Drive Controls.

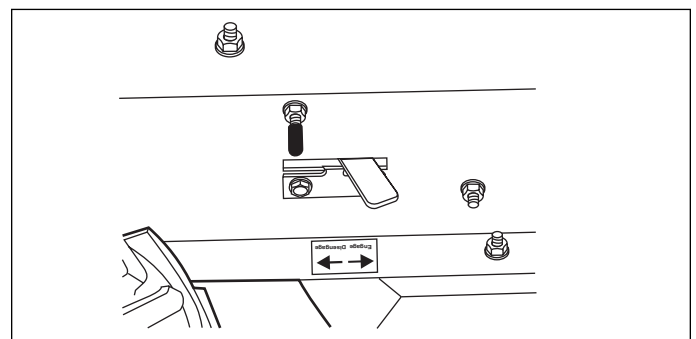

Figure 4 - Traction Drive / Freewheel Control

Operating the Mower

To Propel Unit Forward:



IMPORTANT NOTE
IN CASE OF EMERGENCY, SUCH AS LOSS OF CONTROL OR POTENTIAL COLLISION, RELEASE TRACTION DRIVE ENGAGEMENT BAR. THIS WILL IMMEDIATELY DISENGAGE THE TRANSMISSION AND STOP MOWER MOVEMENT. THE ENGINE WILL CONTINUE TO RUN.

- Grasping both upper handle/safety bar (A, Figure 5) and lower portion of traction drive engagement bar (B) with both hands, slowly begin squeezing engagement bar up toward handle. The unit should begin moving forward.

DANGER

Do not pass by or stand on the discharge side of brush mower with its engine running and blade engaged.

To Propel Unit In Reverse:

- Grasping both upper handle/safety bar (A, Figure 6) and upper portion of traction drive engagement bar (B), slowly squeeze bar back toward handle. The unit should begin moving backwards.

The further the engagement bar is moved toward the handle, the more the unit will accelerate. Likewise, slowly releasing pressure on the bar will slowly decelerate the unit. Releasing engagement bar altogether will disengage transmission completely.

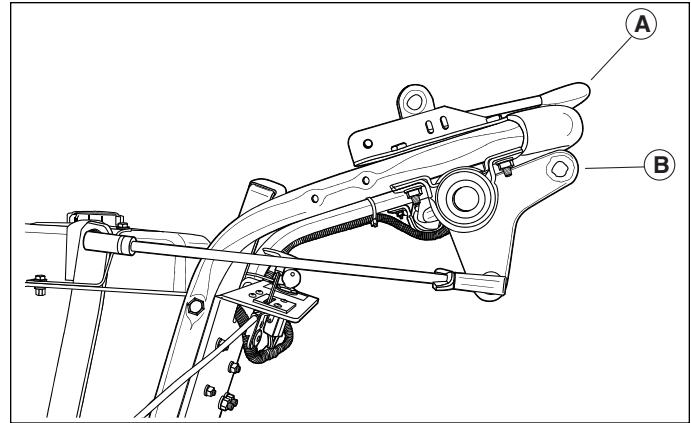

Figure 5 - Forward Travel

- A. Safety Bar**
- B. Forward Traction Drive Bar**

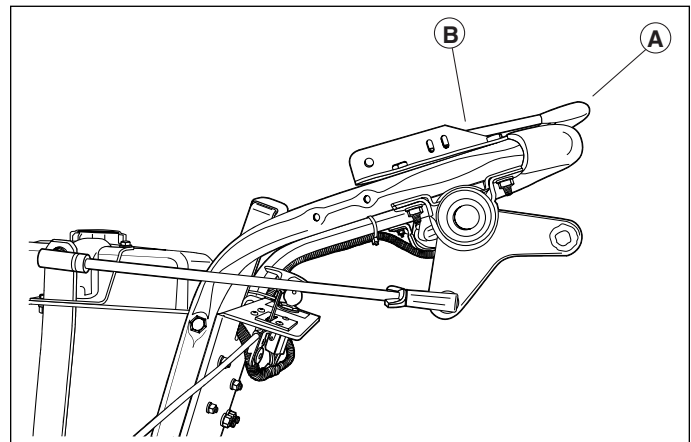

Figure 6 - Reverse Travel

- A. Safety Bar**
- B. Reverse Traction Drive Bar (in front of handle)**

ENGAGING/DISENGAGING THE CUTTING BLADE

⚠ DANGER

Do not pass by or stand on the discharge side of brush mower with its engine running and blade engaged.

To Engage Cutting Blade:

- Push Blade Engagement Lever forward and then to the right until lever locks into place (Figure 7).

⚠ WARNING

Engaging cutting blade will activate engine safety kill feature. This feature uses the spring-loaded safety bar, located above the handle, which will allow the engine to run only when safety bar is depressed against the handle. Releasing the safety bar will automatically shut engine off. This “Safety Engine Kill” feature is active only when cutting blade is engaged.

DO NOT ATTEMPT TO DEFEAT THIS SAFETY FEATURE. SERIOUS INJURY OR DEATH MAY OCCUR.

To Disengage Cutting Blade:

Push the Blade Engagement Lever forwards slightly to clear the LOCK position.

Pull Blade Engagement Lever back against control panel (Figure 8).

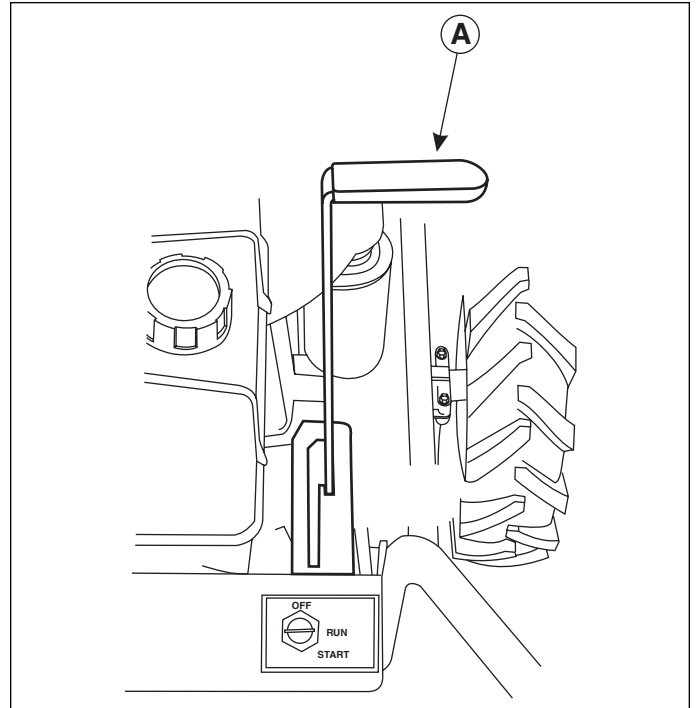

Figure 7 - PTO Engaged
A. Blade Engagement Lever in engaged position.

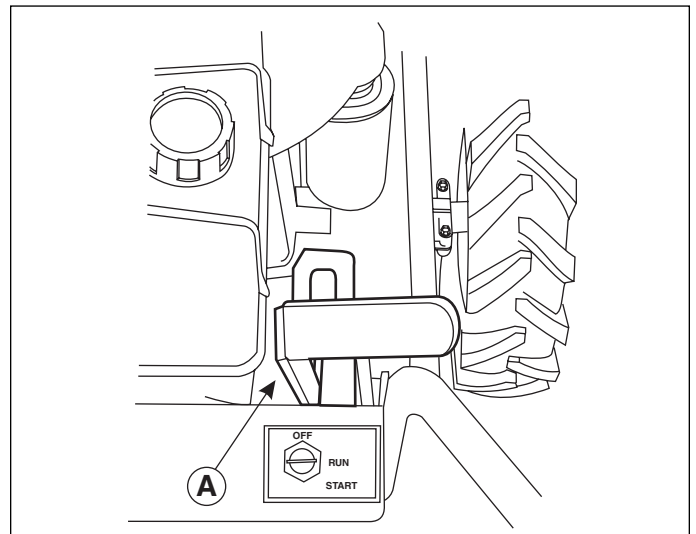

Figure 8 - PTO Disengaged
A. Blade Engagement Lever in the disengaged position.

Operating the Mower

TO ADJUST CUTTING HEIGHT

The front skids on the brush cutter have 3 sets of holes (Figure 9) for height adjustment:

- Top holes - 3 1/4" cutting depth
- Center holes - 4" cutting depth
- Bottom holes - 4 3/4" cutting depth
- Shut off engine.
- Loosen bolts holding skids.
- Move skid to desired location.
- Reinstall bolts.

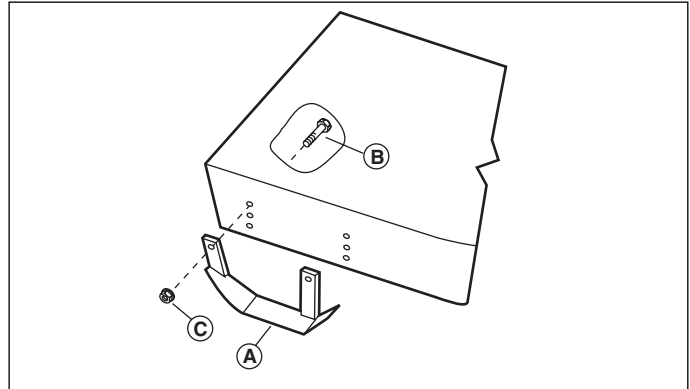

Figure 9 - Adjusting Height

- A. Skid**
- B. Capscrew**
- C. Flange Nut**

STORAGE

WARNING

Never store the unit (with fuel) in an enclosed, poorly ventilated structure. Fuel vapors can travel to an ignition source (such as a furnace, water heater, etc.) and cause an explosion. Fuel vapor is also toxic to humans and animals.

Before you store your unit for the off-season, read the Maintenance and Storage instructions in the Safety Rules section, and then perform the following steps:

- Disengage the PTO and remove the key.
- Perform engine maintenance and storage measures listed in the engine owner's manual. This includes draining the fuel system, or adding stabilizer to the fuel (do not store a fueled unit in an enclosed structure - see above).

- Battery life will be increased if it is removed, put in a cool, dry place and fully charged about once a month. If the battery is left in the unit, disconnect the negative cable.

Before starting the unit after it has been stored:

- Check all fluid levels. Check all maintenance items.
- Perform all recommended engine checks and procedures found in the engine owner's manual.
- Allow the engine to warm up for several minutes before using mower.

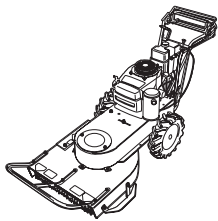

Regular Maintenance

LUBRICATION

Service Interval: Every 25 Hours

Lubricate the unit at the locations shown in Figure 10 as well as the lubrication points listed. Generally, all moving parts should be oiled where contact is made with other parts. Keep oil and grease off belts and pulleys. Wipe surfaces clean before and after lubrication.

Grease:

- blade arbor

Note - This grease point is located under the blade deck, on the arbor.

Oil:

- traction drive control linkage
- blade engagement lever
- axle shafts

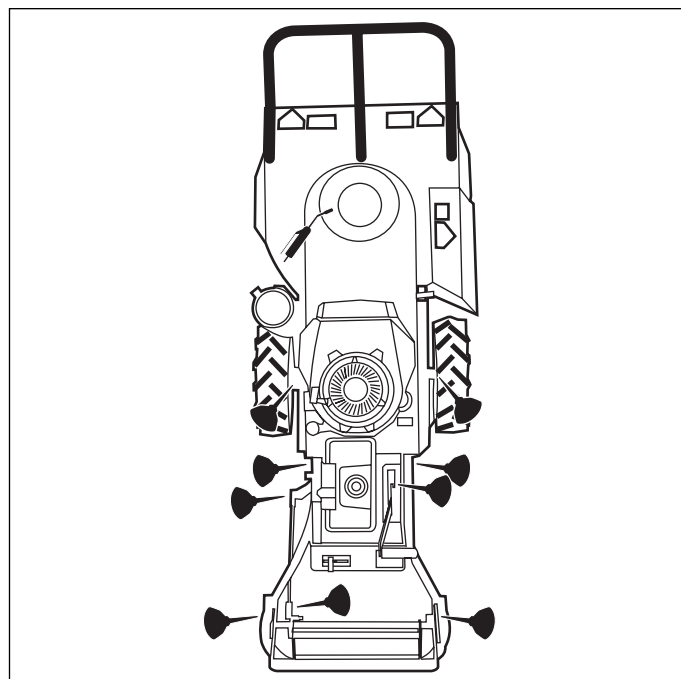

Figure 10 - Lubrication Points

Lubricate Rear Axle Shafts

Service Interval: Yearly

We recommend removing the rear wheel hubs and lubricating the axle shafts yearly. This prevents the wheel hubs from seizing onto the axle shaft and makes future service easier.

1. Turn off the ignition, disengage the PTO.
2. Using a jack or chain hoist positioned at the center of the rear frame, carefully lift the unit up until the rear tires are approximately 1" - 2" (2.5-5 cm) off the ground.

Note: For overall unit stability during service, do not jack rear end higher than required for wheel removal.

3. Support the rear of the unit on jack stands positioned under the rear frame.
4. Remove the hardware retaining the wheel assembly to the axle (Figure 11) and lubricate the axle shaft using anti-seize compound or lithium grease.
5. Reinstall the components in reverse order of disassembly and lower the unit. Be sure the key (A, Figure 11) is in place in the axle keyway.

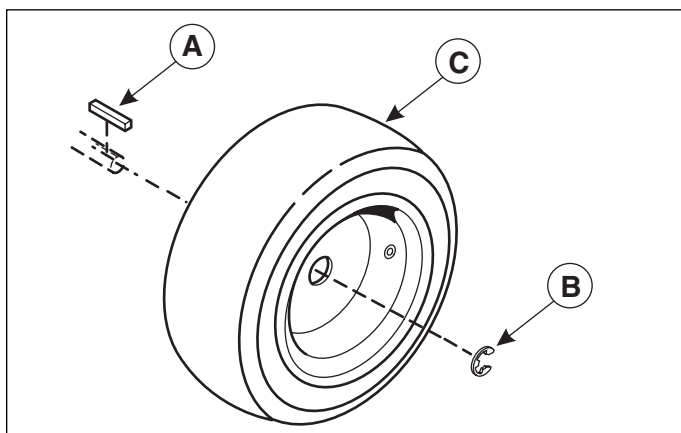

Figure 11. Axle Shaft

- A. Key
- B. Retaining Ring
- C. Wheel & Hub

Regular Maintenance

TIRE PRESSURE

Tire pressure is 20 psi (1.4 bar).

BATTERY SERVICE

WARNING

When removing or installing battery cables, disconnect the negative cable **FIRST** and reconnect it **LAST**. If not done in this order, the positive terminal can be shorted to the frame by a tool.

Cleaning the Battery and Cables - 9HP Models

Service Interval: Every 100 Hours

1. Disconnect the cables from the battery, negative cable first (C, Figure 13a).
2. Remove the battery hold-down (B), rubber protective sheet (D) and battery (A).
3. Clean the battery compartment with a solution of baking soda and water.
4. Clean the battery terminals and cable ends with a wire brush and battery terminal cleaner until shiny.
5. Reinstall the battery in the battery compartment, place rubber sheet (D) on top of battery and secure with the battery hold-down (B).
6. Reattach the battery cables, positive cable first (C).
7. Coat the cable ends and battery terminals with petroleum jelly or non-conducting grease.

Cleaning the Battery and Cables - All Models Except 9HP

Service Interval: Every 100 Hours

1. Turn the fuel valve OFF (the fuel valve is located under the fuel tank).
2. Remove the two 5/16-18 x 3/4 hex bolts (A, Figure 13b) securing the fuel tank assembly (B) to the unit.
3. Place a container under the fuel valve to catch spilled fuel, and remove the clamp securing the fuel line to the fuel valve.
4. Lift the fuel tank assembly off the unit and set it aside. Be careful to avoid spilling fuel.
5. Perform the battery (C) removal, cleaning, and installation procedures found above in **CLEANING THE BATTERY AND CABLES - 9HP MODELS**
6. Reverse steps 1-4 to reinstall the fuel tank. Be sure all fasteners and fuel line connections are tight before starting the unit.

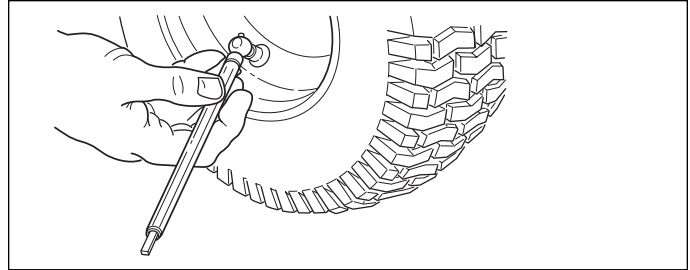

Figure 12. Check Tire Pressure

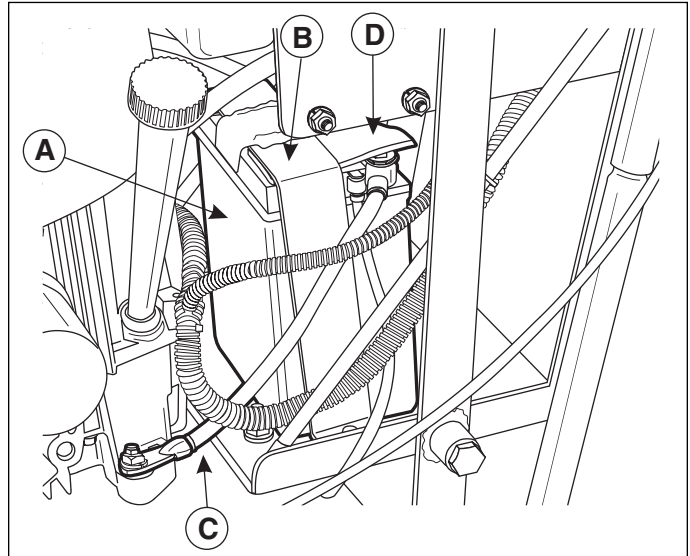

Figure 13a. Battery

A. Battery

B. Hold Down Clamp

C. Negative Battery Cable

D. Rubber Sheet

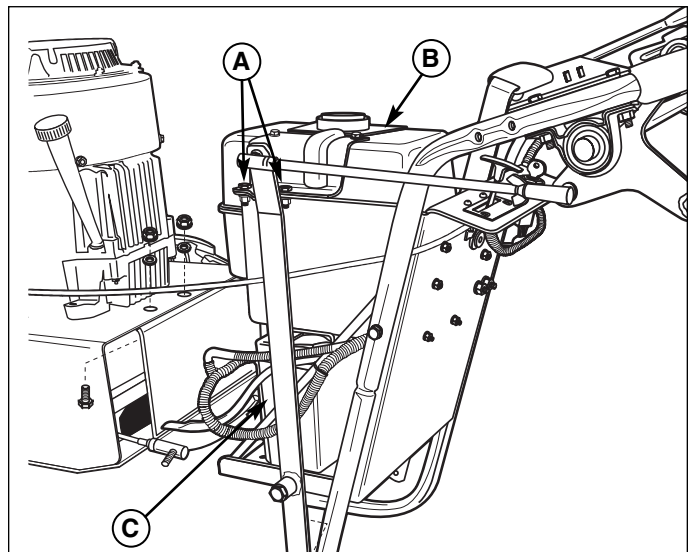

Figure 13b. Battery

A. 5/16-18 x 3/4 Hex Bolts

B. Fuel Tank Assembly

C. Battery

SERVICING THE MOWER BLADES

⚠ WARNING

For your personal safety, do not handle the sharp mower blades with bare hands. Careless or improper handling of blades may result in serious injury.

Service Interval: Every 100 Hours or As Required

1. Raise the front end of the brush mower and securely support in the raised position.
2. Blades should be sharp and free of nicks and dents. If worn or damaged, replace the blades as described in following steps.
3. To remove the blade, use a wood block to hold blade while removing the blade mounting capscrew (Figure 14). Note: Hex head bolt shown. Your mower may be equipped with a socket head capscrew.
4. Remove and set aside the cutting blade reinforcement channel.
5. Install the new blade into the reinforcement channel with the lift tabs pointing up toward deck (Figure 15). Secure with the capscrew and lockwasher. Use a wooden block to prevent blade rotation and torque capscrew (C, Figure 15) to 233 ft. lbs. (315 N.m.).

⚠ WARNING

For your personal safety the blade mounting capscrew must be installed with a lockwasher, then securely tightened. Torque blade mounting capscrew to 233 ft. lbs. (315 N.m.)

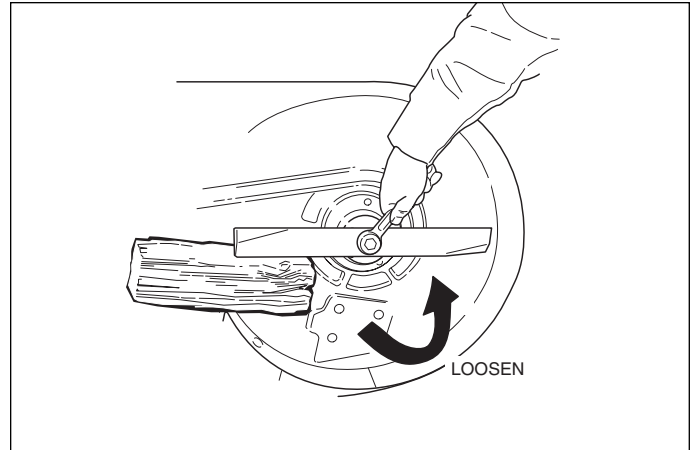

Figure 14 - Removing the Blade

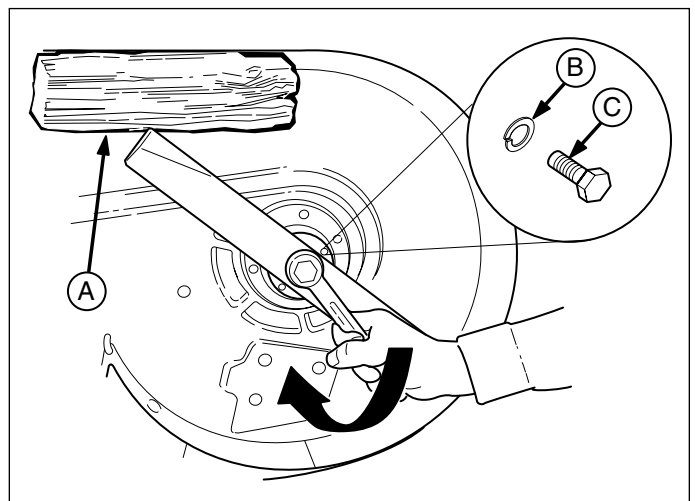
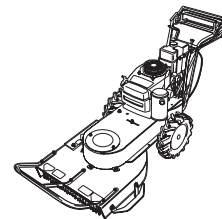

Figure 15 - Installing The Blade

- A. 4x4 Wood Block
- B. Lockwasher
- C. Capscrew

Troubleshooting, Adjustment, & Service



TROUBLESHOOTING

PROBLEM	CAUSE	REMEDY
Engine will not turnover or start.	<ol style="list-style-type: none"> 1. PTO lever in the engaged position. 2. Out of fuel. 3. Engine flooded. 4. Battery terminals require cleaning. 5. Clogged fuel filter. 6. Battery discharged or dead. 7. Wiring loose or broken. 8. Solenoid or starter motor faulty. 9. Safety interlock switch faulty 10. Spark plug(s) faulty, fouled or incorrectly gapped. 11. Water in fuel. 12. Gas is old or stale. 	<p>Place in disengaged position. If the engine is hot, allow it to cool, then refill the fuel tank. Disengage choke. See Battery Maintenance Section. Turn off fuel and replace filter. Recharge or replace. Visually check wiring & replace broken or frayed wires. Tighten loose connections. See your dealer. See your dealer. Clean and gap or replace. See engine manual.</p> <p>Drain fuel & refill with fresh fuel. Replace fuel filter. Drain fuel & refill with fresh fuel. Replace fuel filter.</p>
Engine will not stay running while operating machine	<ol style="list-style-type: none"> 1. Safety bar on handlebar assembly released with blade clutch engaged. 2. Safety bar not fully depressing safety switch. 3. Choke staying on. 4. Low or no fuel. 5. Fuel valve shut off. 	<p>Press and hold safety bar while operating unit See your dealer. Throttle down slightly after starting to disengage automatic choke. Add fuel. Turn fuel valve on.</p>
Engine starts hard or runs poorly.	<ol style="list-style-type: none"> 1. Fuel mixture too rich. 2. Spark plug(s) faulty, fouled, or incorrectly gapped. 3. Choke engaged. 4. Fuel filter dirty. 5. Air filter dirty. 	<p>Clean air filter. Check choke adjustment Clean and gap or replace. See engine manual. Throttle down slightly after starting to disengage automatic choke. Replace fuel filter. Replace air filter.</p>
Engine knocks.	<ol style="list-style-type: none"> 1. Low oil level. 2. Using wrong grade oil. 	<p>Check/add oil as required. See engine manual.</p>
Excessive oil consumption.	<ol style="list-style-type: none"> 1. Engine running too hot. 2. Using wrong weight oil. 3. Too much oil in crankcase. 	<p>Clean engine fins, blower screen and air cleaner. See engine manual. Drain excess oil.</p>
Engine exhaust is black.	<ol style="list-style-type: none"> 1. Dirty air filter. 2. Choke closed. 	<p>Replace air filter. See engine manual. Open choke.</p>
Engine runs, but mower will not drive.	<ol style="list-style-type: none"> 1. Traction drive control not engaged. 2. Drive belt is broken. 3. Drive belt slips. 	<p>Engage traction drive control. See Drive Belt Replacement. See cause and remedy below.</p>
Engine stalls easily with mower engaged.	<ol style="list-style-type: none"> 1. Engine speed too slow. 2. Ground speed too fast. 3. Carburetor improperly adjusted. 4. Cutting height set too low. 5. Discharge chute jamming with cut grass. 6. Engine not up to operating temperature. 7. Starting mower in tall grass. 	<p>Set to full throttle. Slow down. See Engine Manual. Cut tall grass at maximum cutting height during first pass. Cut grass with discharge pointing toward previously cut area. Run engine for several minutes to warm-up. Start the mower in a cleared area.</p>

Troubleshooting Cont.

Blade will not engage.	<ol style="list-style-type: none"> 1. Blade clutch rod too loose. 2. Blade belt worn or broken. 3. Over-stretched or broken spring on blade clutch rod. 4. Worn blade clutch. 	<p>See Blade Clutch Adjustment Section. Turn off engine and inspect belt. Adjust or replace as required.</p> <p>Turn off engine and inspect spring. Replace as needed. Replace clutch.</p>
Blade will not disengage or Blade stop time over 5 seconds.	<ol style="list-style-type: none"> 1. Blade clutch rod adjustment too tight or brake worn. 2. Broken or jammed blade clutch. 	<p>See Blade Clutch Adjustment Section</p> <p>Replace clutch.</p>
Mower drive belt slips.	<ol style="list-style-type: none"> 1. Clutch is out of adjustment. 2. Pulleys or belt greasy or oily. 3. Belt stretched or worn. 4. Idler pulley out of adjustment. 	<p>See Adjustments Section. Clean as required. Replace with new belt. See Adjustments Section.</p>
Mower cut is uneven.	<ol style="list-style-type: none"> 1. Mower not leveled properly. 2. Mower tires not inflated equally or properly. 	<p>See Mower Adjustment. See Maintenance Section.</p>
Mower cut is rough looking.	<ol style="list-style-type: none"> 1. Engine speed too slow. 2. Ground speed too fast. 3. Blades are dull. 4. Mower drive belt slipping because it is oily or worn. 5. Check PTO Adjustment. 6. Blade not properly fastened to arbor. 7. Blade screw is loose. 	<p>Set to full throttle. Slow down. Replace blade. See Mower Blade Service. Clean or replace belt as necessary</p> <p>See Adjustments Section. See Servicing the Mower Blades.</p> <p>Turn off engine and tighten blade screw.</p>
Excessive mower vibration.	<ol style="list-style-type: none"> 1. Blade mounting screw is loose. 2. Mower blade, arbor, or pulleys are bent. 3. Mower blade is out of balance. 4. Belt installed incorrectly. 5. Foreign objects caught on or wrapped around blade. 	<p>Tighten to 233 ft.lbs. (315 N.m.). Check and replace as necessary.</p> <p>Remove and balance blade. See Servicing the Mower Blades. Reinstall Correctly. Turn off engine and remove foreign materials from around blade.</p>
Excessive belt wear or breakage.	<ol style="list-style-type: none"> 1. Bent or rough pulleys. 2. Using incorrect belt. 	<p>Repair or replace. Replace with correct belt.</p>

TRAVEL CONTROL ADJUSTMENT

Serial Number 0-011903999

1. The Travel Control engagement bars (A, Figure 16a) should be an equal distance from the Upper Handle Bar. If they are not, adjust their position.
2. Loosen the wing nut locknut (D) and rotate control rod (C) until engagement bars are properly adjusted.
3. Tighten locknut to secure adjustment.

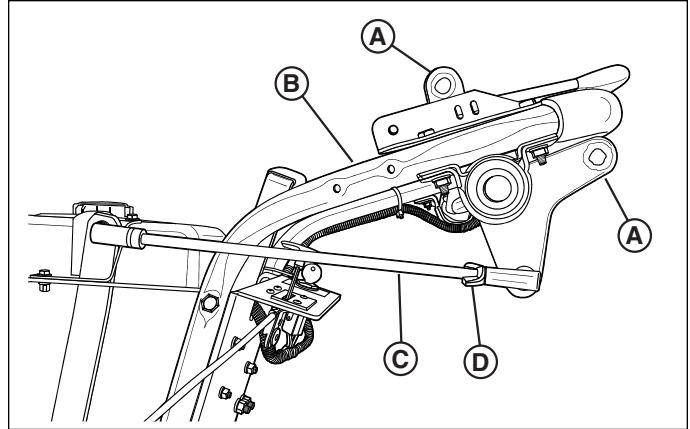

Figure 16a - Travel Controls Adjustment

- A. Engagement Bars
- B. Upper Handle
- C. Control Rod
- D. Wing Nut Locknut

Serial Number 012003001-Up

The Travel Control engagement bars (A, Figure 16b) can be adjusted to provide the optimum ratio of forward/reverse travel speed.

1. Remove the hair pin clip (B, Figure 16b).
2. Relocate the L-shaped end of the control rod (C) into one of the four speed adjustment holes in the engagement bar side plate.

The rearmost hole will provide the most forward speed and the least reverse speed, and vice-versa. Finer adjustment can be obtained by loosening the jam nut (D) and turning the rod in or out.

3. Secure the in the desired position by replacing the hair pin clip (B).

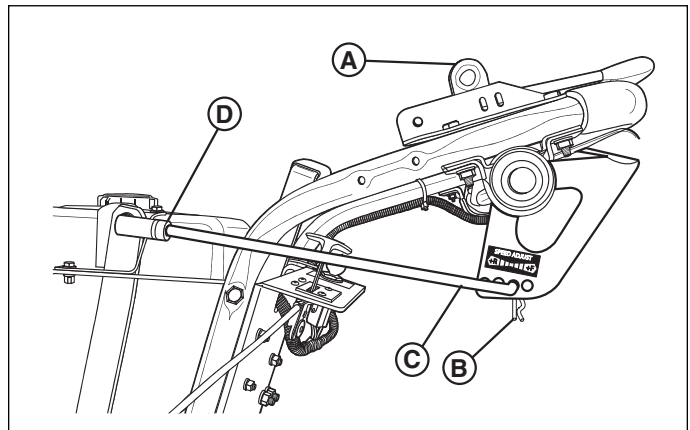

Figure 16b - Travel Controls Adjustment

- A. Engagement Bars
- B. Hair Pin Clip
- C. Control Rod
- D. Jam Nut

BLADE CLUTCH ADJUSTMENT

WARNING

Shut off engine before attempting this adjustment procedure.

If the mower blade does not stop running when the blade clutch lever is in the DISENGAGED position, does not run at full speed, adjust the Blade Clutch tension.

1. Remove clutch cover plate (A, Figure 19).
2. Loosen nut (D, Figure 17).
3. Remove hairpin clip (E).
4. Slide clutch rod fitting (C) out of blade clutch lever (B).
5. Move clutch rod lever (B) to fully disengaged position.
6. Push forward on the blade clutch engagement lever (Figure 18).
7. Adjust nut (D) and clutch rod fitting (C) until there is no tension on the spring and minimal slack (approximately 1/16") when the fitting is placed into hole in the blade clutch lever.
8. Attach clutch rod fitting to the blade clutch lever using washer and hairpin clip. Tighten nut.
9. Start engine. Blade should not rotate.
10. Engage blade. Blade should come up to full speed.
11. Disengage blade. Blade should stop in 5 seconds or less. Stop engine.
12. Install clutch cover plate.

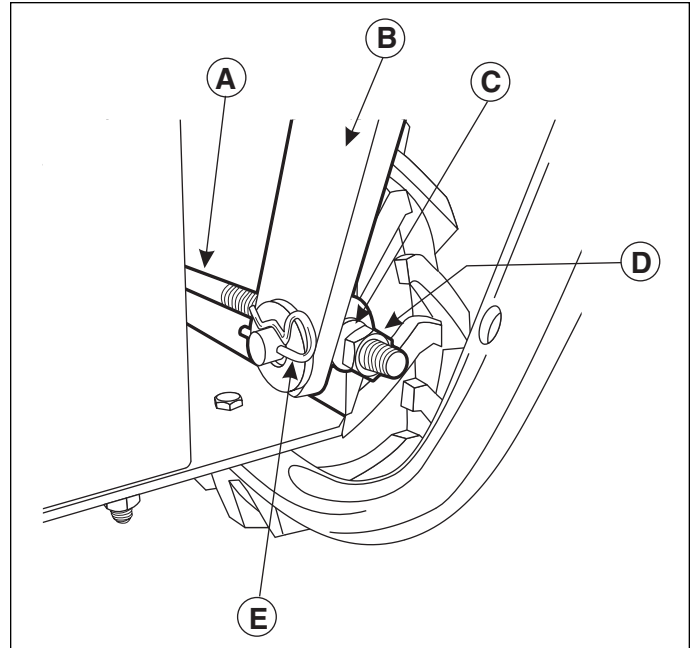

Figure 17 - Blade Clutch Adjustment

- A. Clutch Rod**
- B. Clutch Rod Lever**
- C. Clutch Rod Fitting**
- D. Locknut**
- E. Hairpin Clip**

Troubleshooting, Adjustment, & Service

BLADE BRAKE ADJUSTMENT

WARNING

- DO NOT place hands or feet under mower deck and away from blade.
- This machine is capable of throwing objects and debris. Keep bystanders away.
- DO NOT touch any rotating parts (pulleys, belts, etc.). Loose clothing, gloves, etc. can become entangled.

The mower blade should stop within 5 seconds after the Blade Engagement Lever is moved to the DISENGAGED position. This adjustment is checked by:

1. Remove blade clutch cover plate (A, Figure 19).
2. Start engine.
3. With mower blade engagement lever in the DISENGAGED position, note spindle bolt (A, Figure 18) in center of pulley (bolt is fastened to blade spindle and indicates blade rotation). If clutch rod is adjusted properly, spindle should not turn.
4. Move mower blade engagement lever into the ENGAGED position. Spindle should begin turning.
5. Disengage clutch. Blade should stop turning within 5 seconds. If the blade does not stop within 5 seconds, see Blade Clutch Adjustment Section.

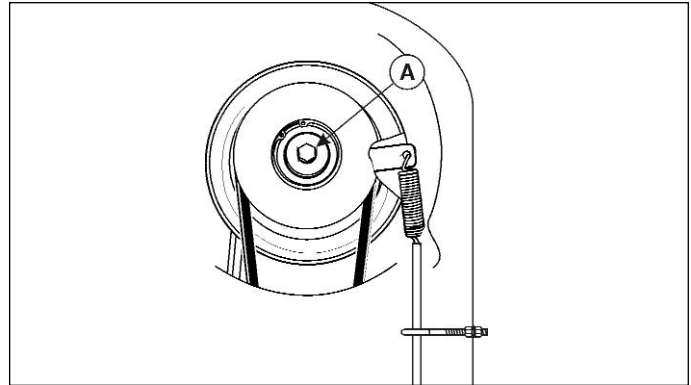

Figure 18 - Blade Spindle Brake
A. Spindle Bolt

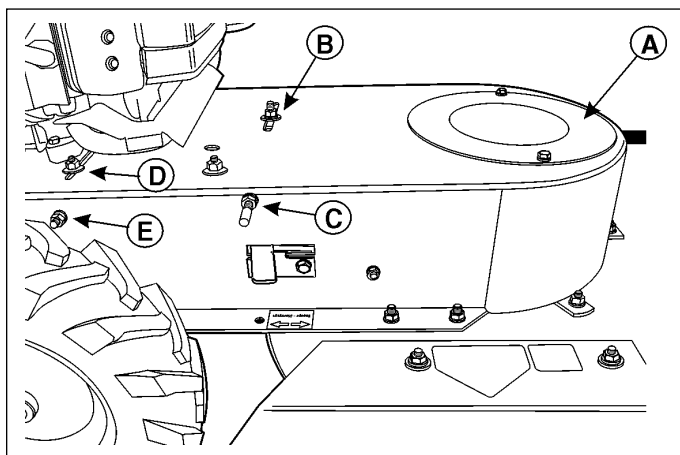

Figure 19 - Belt Adjustments

- A. Clutch Cover Plate
- B. Mower Blade Idler Pulley Lock Nut
- C. Mower Blade Idler Pulley Adjustment Nut
- D. Traction Drive Idler Pulley Lock Nut
- E. Traction Drive Idler Pulley Adjustment Nut

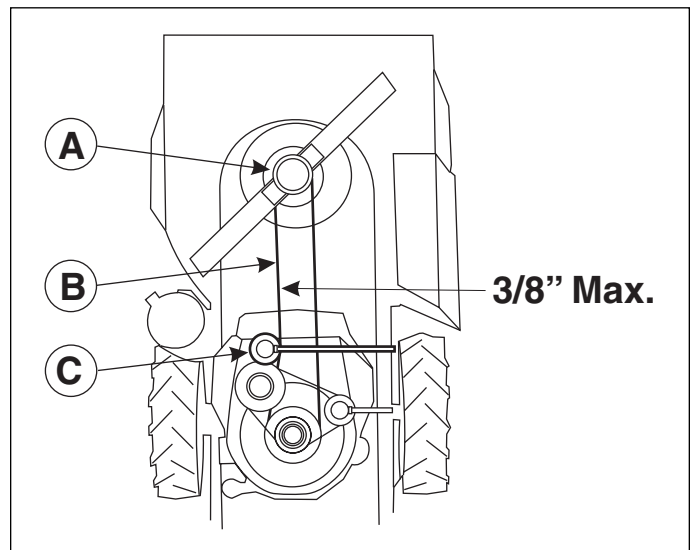

Figure 20 - Mower Belt Deflection

- A. Belt Clutch Pulley
- B. Belt
- C. Idler Pulley

MOWER BELT ADJUSTMENT

If the mower blade drive belt needs adjustment:

1. Loosen mower blade idler pulley lock nut (B, Figure 19).
2. Loosen or tighten mower blade idler pulley adjustment nut (C, Figure 19) as required.
3. Tighten idler pulley lock nut.
4. Test mower and repeat adjustment as required.

TRACTION DRIVE BELT ADJUSTMENT

If the mower drive is not functioning properly, the drive belt may need to be adjusted;

For S/N 0 - 071601075

The traction drive belt tension is adjusted by a bolt and screw system. To adjust belt tension:

1. Loosen traction drive idler pulley lock nut (D, Figure 19).
2. Loosen or tighten traction drive idler pulley adjustment nut (E, Figure 19) as required. Belt deflection should be approximately 1/8" halfway between the engine pulley (C, Figure 21) and idler pulley (D) with 10 lbs. of pressure on the belt.
3. Tighten idler pulley lock nut.
4. Test mower and repeat adjustment as required.

For S/N 071601076 - up

The traction drive belt tension is adjusted through spring tension. To adjust spring tension:

1. Tighten or loosen nut (A, Figure 22) to achieve proper belt tension. Belt deflection should be approximately 1/8" halfway between the engine pulley (C, Figure 21) and idler pulley (D).
2. Tighten adjustment nut of the tension spring until expanded spring length is 6-3/8" maximum. For measurement purposes, the spring can be reached through the access pan beneath the engine.

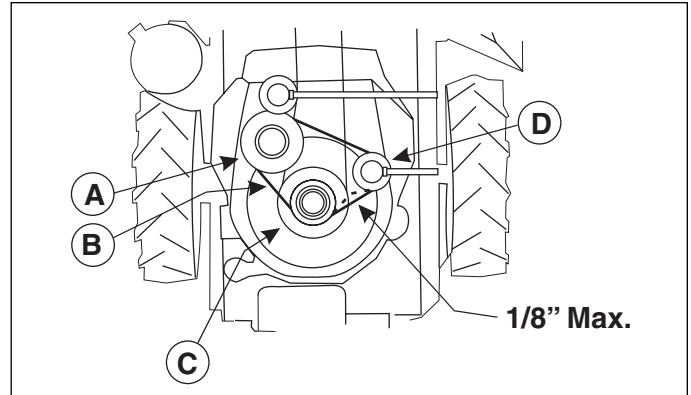

Figure 21 - Traction Drive Belt Adjustment
A. Transmission Pulley
B. Drive Belt
C. Engine Pulley
D. Idler Pulley

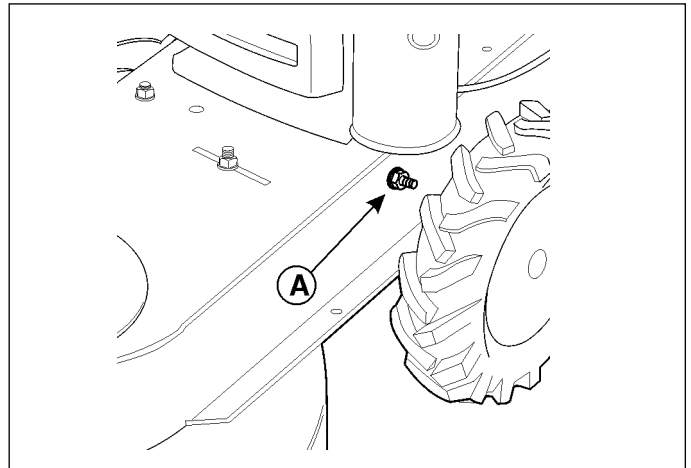

Figure 22 - Traction Drive Belt Adjustment
A. Adjustment Nut

Troubleshooting, Adjustment & Service

MOWER BELT REPLACEMENT

To replace the mower blade drive belt;

NOTE - The traction drive belt will have to be removed before the mower blade belt can be removed.

1. Remove clutch cover plate (A, Figure 23).
2. On early models only, loosen traction drive belt idler pulley lock nut (D, Figure 23) for the traction drive.
3. Loosen idler pulley adjustment by rotating adjustment nut (late models, A, Figure 22) or (early models, E, Figure 23).
4. Reach through rear of unit to remove traction drive belt from lower engine pulley (F, Figure 24).
5. Loosen mower belt idler pulley lock nut (B, Figure 23).
6. Loosen idler pulley adjustment by rotating adjustment nut (C, Figure 23).
7. Reach through rear of unit to remove mower blade drive belt (B, Figure 24) from engine pulley.
8. Remove mower blade drive belt through blade clutch access opening.
9. Reverse above steps 1 - 8 to install new belts.

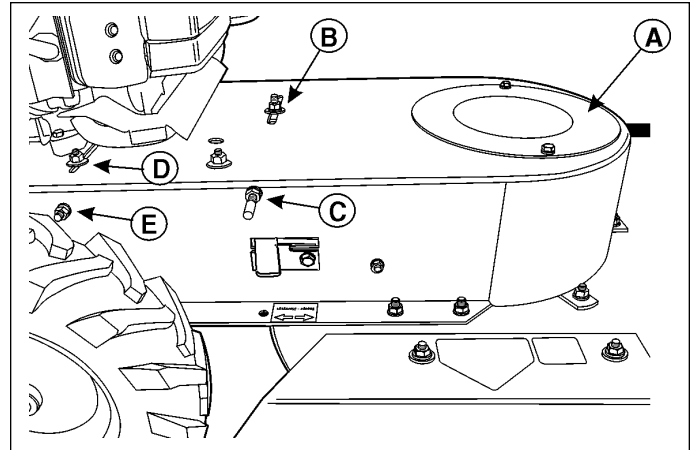

Figure 23 - Belt Adjustments

- A. Clutch Cover Plate**
- B. Mower Blade Idler Pulley Lock Nut**
- C. Mower Blade Idler Pulley Adjustment Nut**
- D. Traction Drive Idler Pulley Lock Nut**
- E. Traction Drive Idler Pulley Adjustment Nut**

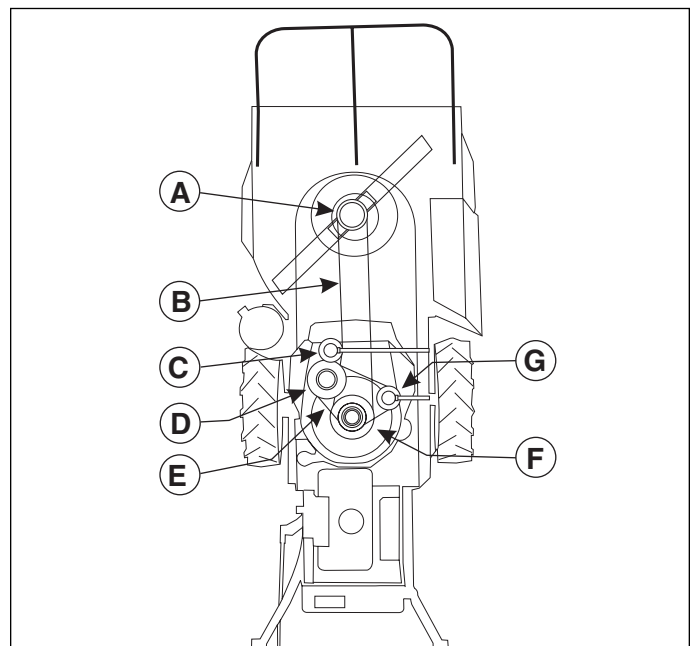
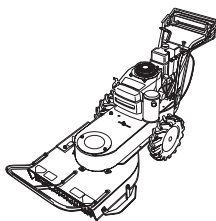

Figure 24 - Belt Alignment

- A. Blade Drive Pulley**
- B. Mower Belt**
- C. Mower Tension Idler**
- D. Transmission Pulley**
- E. Transmission Belt**
- F. Engine Pulley**
- G. Transmission Tension Idler**



Specifications

NOTE: Specifications are correct at time of printing and are subject to change without notice.

** Actual sustained equipment horsepower will likely be lower due to operating limitations and environmental factors.*

ENGINEI	BRIGGS	HONDA	KAWASAKI	BRIGGS
Engine	13 HP B&S	13 HP Honda	15 HP V-twin	16 HP B&S
Transmission	Hydro/Variable	Hydro/Variable	Hydro/Variable	Hydro/Variable
Ground Speed (mph)	Infinite (.01 - 6)	Infinite (.01 - 6)	Infinite (.01 - 6)	Infinite (.01 - 6)
Weight (lbs)	287	298	299	N/A
Overall Length (in)	84	84	84	84
Width (in)	32	32	32	32
Cut Width (in)	25	25	25	25
Height (in)	39	39	39	39

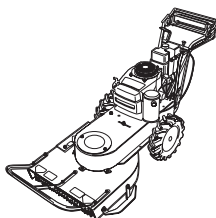

Parts & Accessories

REPLACEMENT PARTS

Replacement parts are available from your authorized dealer. Always use genuine Service Parts.

MAINTENANCE ITEMS

Many convenient and helpful service and maintenance items are available from you authorized dealer. Some of these items include:

Touch-Up Paint
Grease Gun Kit
8 oz. Grease Tube

Tire Sealant
Degrimer/Degreaser
Gas Stabilizer

TECHNICAL MANUALS

Additional copies of this manual are available, as well as fully illustrated parts lists.

For applicable manuals currently available for your model, contact your authorized dealer or the manufacturer for information. Have the information listed in the box below available when phoning in your request.

Model:	_____
Mfg. No.:	_____
Your Name:	_____
Address:	_____
City, State, Zip:	_____
Visa/Mastercard No.:	_____
Card Expiration Date:	_____

Notes



A Division of Simplicity Manufacturing, Inc.
535 Macon Street/PO Box 777
McDonough, GA 30253

© Copyright 2005
All Rights Reserved. Printed in USA.