

SCAG®

COMMERCIAL EDGER TECHNICAL MANUAL

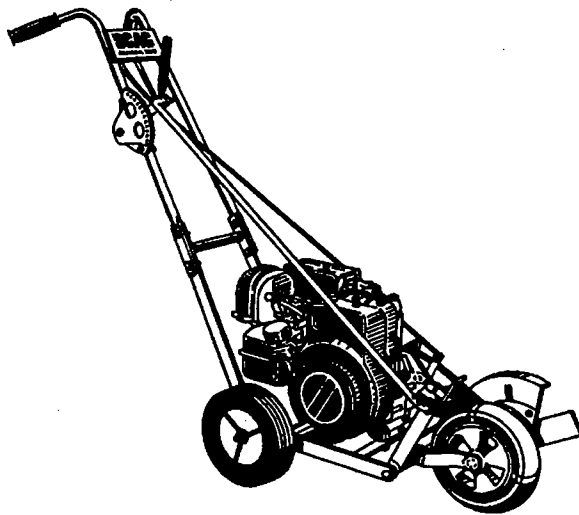

MODELS

SE-3BS
SE-3KA

Table of Contents

Safety Instructions	1
Know How To Use the Edger	1
Dress Properly	1
Check the Edger Before You Use It	1
Check Out the Area Before You Start Work	1
Stay Alert	1
Operate the Edger With Care	2
Keep Hands and Feet Away From the Blade!	2
Handle Gasoline with Care	2
Follow Maintenance Instructions Carefully	3
Multiple Operators	3
Setup	3
Operating Instructions	4
Before Routine Operation	4
Starting the Engine	4
Operation	5
Maintenance	6
Changing Engine Oil	6
Changing the Belt	6
Changing the Blade	7
Rubber Debris Deflector	7
Cleaning the Air Filter	8
Assembly	8
Lubrication	8
Troubleshooting Guide	9
Parts List	11
Warranty	12

Read and understand the contents of this manual before operating the machine. A free replacement manual is available upon request; send the complete model and serial number of your edger to:

Scag Power Equipment, Inc.
1000 Metalcraft Drive
Mayville, WI 53050

Safety Instructions

Your edger is only as safe as **YOU**, the operator, make it! As with any other power equipment, carelessness or error can result in serious bodily injury. Improper maintenance can also result in injury. To reduce the potential for injury, follow these instructions on safe operation. Be certain that anyone using this edger fully understands and complies with these safety instructions.

Know how to use the edger.

- Be thoroughly familiar with the controls and the proper use of the equipment.
- Know how to stop the edger and disengage the controls quickly.
- Use the edger only on flower beds, lawns and shrubs.
- Always stay behind the handles. Stones and other items thrown by blade can cause injury. (See figure 1)

Dress Properly.

- Wear safety glasses or goggles.
- Do not wear loose clothing or jewelry; they can be caught in moving parts.
- Sturdy gloves and safety footwear are recommended.
- Always wear pants that cover legs.

Check the edger before you use it.

- Never operate the edger unless guards and other protective devices are in place.
- Before you use the edger, make sure all nuts, bolts, and screws are installed and properly tightened.

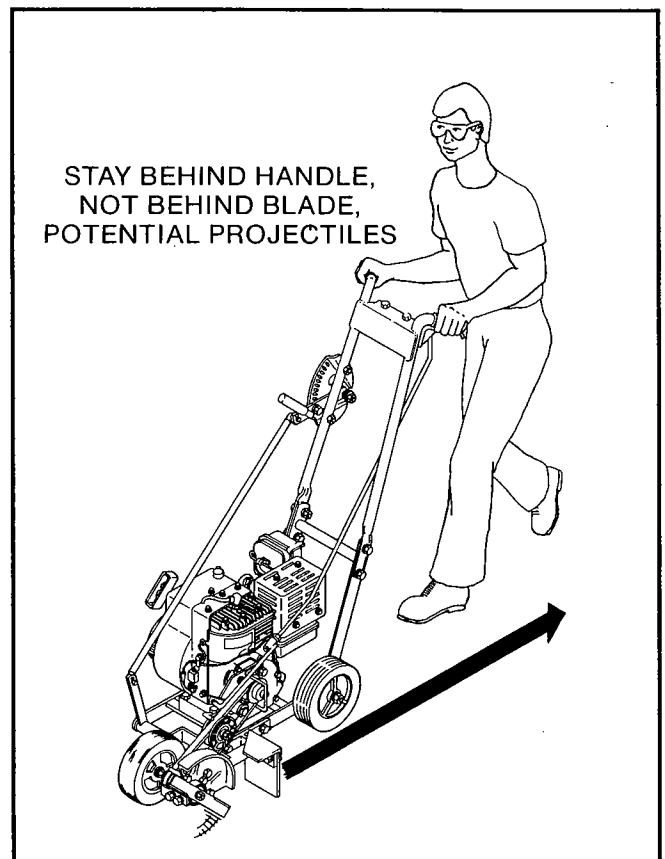

Figure 1

- Where applicable, check pulley setscrews and all fasteners for tightness and lubricate periodically as described in Maintenance Section.

Check out the area before you start work.

- Be aware of conditions in your work area. Carefully examine the area before edging.
- Clear the lawn of all foreign objects before edging. Foreign objects thrown by the blade can injure people.
- Keep the area of operation clear of all persons and pets. (Figure 2)
- Do not use the edger on graveled surfaces. Gravel thrown by the blade can cause injury.

Stay alert.

- Watch what you are doing, and use common sense.
- Do not operate the edger when you are fatigued or under the influence of alcohol or drugs.

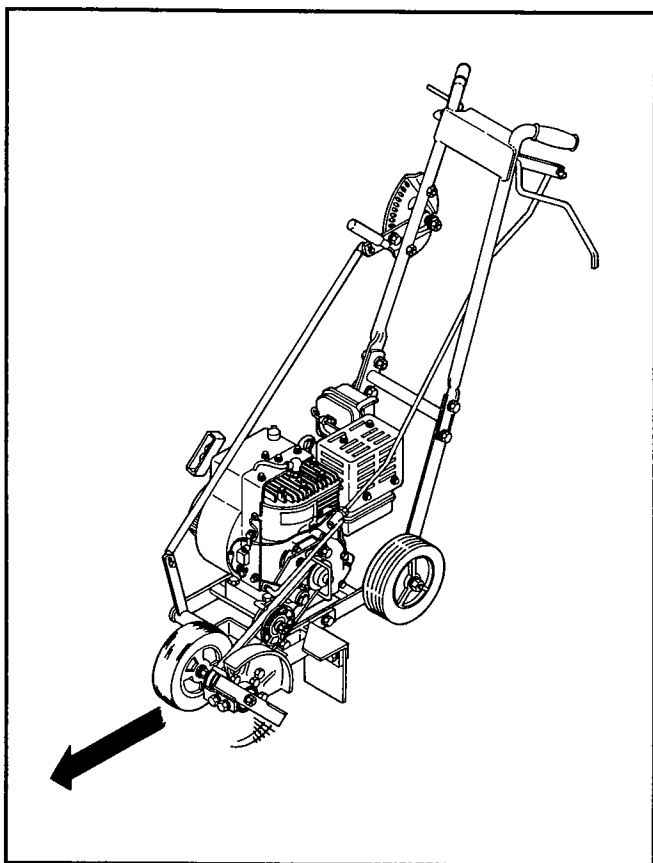

Figure 2

Operate the edger with care.

- Keep hands, feet, clothing, and the like well away from the blade and moving parts.
- Don't overreach or stand on unstable support. Keep good footing and balance at all times.
- Start the engine carefully.
- Stop the engine when leaving the edger unattended.
- Do not operate the edger with a damaged or excessively worn blade.
- Never attempt to make adjustments while the engine is running, except to the carburetor.
- Never direct discharge of material toward people. Also use care in directing discharge to avoid glass enclosures, automobiles and the like.
- Never operate the edger without good visibility or light.
- Stay alert for uneven sidewalks, holes in terrain, or other similar conditions when using the edger. Always push slowly over rough ground.
- Always keep the throttle in the STOP position when the edger is not in use.

- If the edger strikes a foreign object, (1)stop the engine; (2)disconnect the spark plug lead; (3)inspect for damage; (4)repair any damage before restarting and operating the edger.

Keep hands and feet away from the blade!

Danger: Rotating blade is sharp and can severely cut body parts. The blade coasts after the edger is turned off.

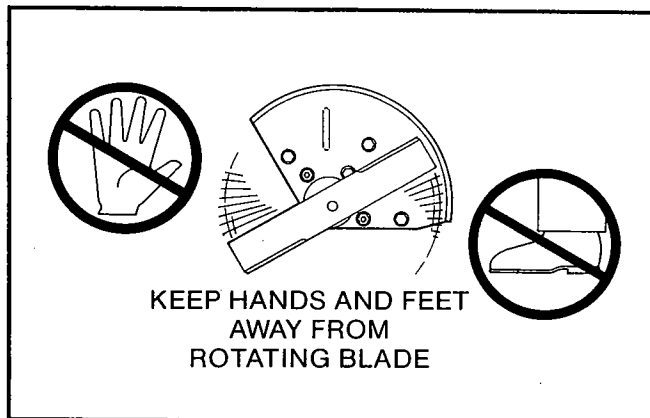

- Keep both hands on the handles when the blade is rotating.
- Keep your feet and hands away from the cutting area.
- Do not attempt to remove cut material or hold material to be cut when the engine is running or the blade is moving.
- Make sure the spark plug wire is disconnected when clearing jammed material from the blade or cutter head.
- Disengage the blade and stop the engine when the edger is transported or not in use.

Handle gasoline with care.

- Gasoline is highly flammable. Never add gas to a running or hot engine.
- Refuel outdoors in open area only. Never fill the gas tank indoors.
- After operating edger, stop engine and wait one minute so engine can cool before refueling.
- To reduce the risk of fire, replace the gasoline cap securely after adding fuel to tank.
- Use a gas container suitable for the purpose.
- Do not store gas in a house.
- If gas is spilled, move the edger and the gas container from the area and do not create a source of ignition.

Follow maintenance instructions carefully.

- Disconnect the spark plug lead before servicing, cleaning, and changing the blade, belt, etc.
- To reduce the risk of fire, do not allow excessive grass, leaves, or grease to accumulate on the edger.
- Do not attempt to make repairs other than those identified in this manual. Repairs not detailed in this manual should be performed by a qualified dealer or service representative. See that only identical replacement parts are used.
- When cleaning, repairing, or inspecting the edger, make certain the blade and all moving parts have stopped. Disconnect the spark plug wire, and keep the wire away from the plug so the unintentional starting does not occur.
- When lifting or transporting the machine, firmly grasp a solid part of the frame. Do not lift by clutch or height adjustment assemblies. **Blade is sharp!** Be careful of blade when lifting.
- Do not run the edger indoors; exhaust fumes are dangerous.
- Store the edger indoors. When not in use, store it in a dry place that is locked or otherwise inaccessible to children.

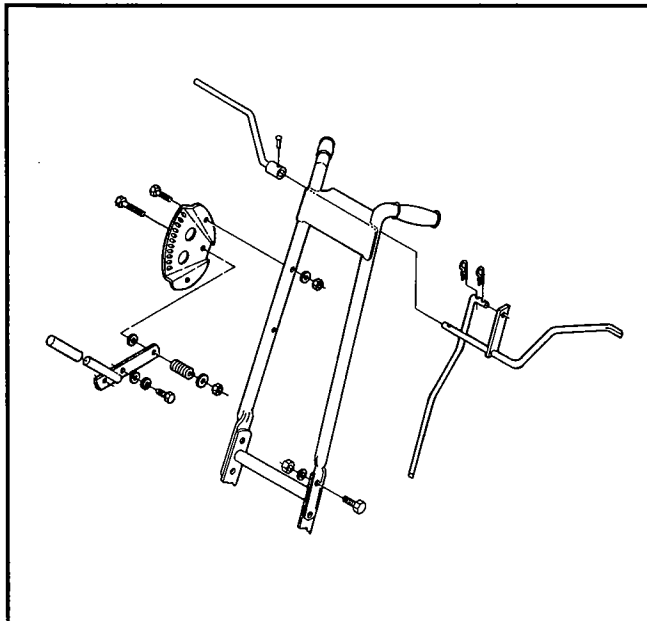

Figure 3

Multiple operators

- Keep a safe distance between two or more operators when working together at the same time.

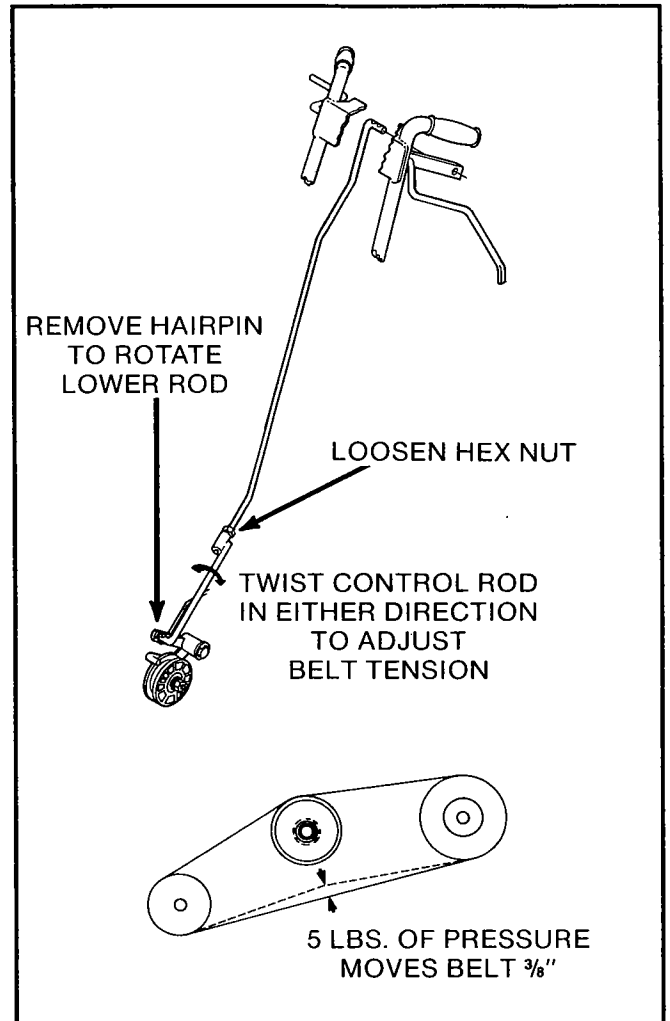

Figure 4

Setup

1. Install upper handle assembly with bolts as shown in Figure 3 using (4) 5/16-18 x 1, (4) 5/16 lockwashers and (4) 5/16 hex nuts.
2. Attach height adjustment index to upper handle assembly using (2) 5/16-18 x 1-1/2" hex head bolts, (2) 5/16 flat washers, and (2) 5/16-18 elastic stop nuts.
3. Install tube-type control rod on right hand side between front wheel height lever and index quadrant using (4) hair pin cotter to secure it.
4. Install operator presence safety control rod with the long rod at the top and the short rod at the idler pulley arm using hair pin cotter. Adjust length of rod for normal tension of belt. (See Figure 4) Fill engine with oil as described under Operating Instructions. Lubricate all grease fittings with lithium based grease.

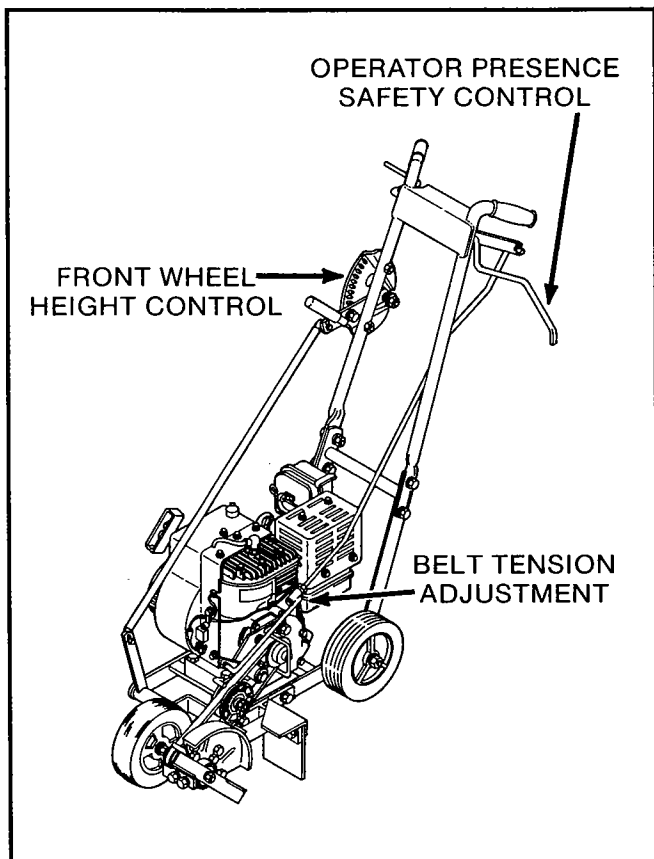

Figure 5

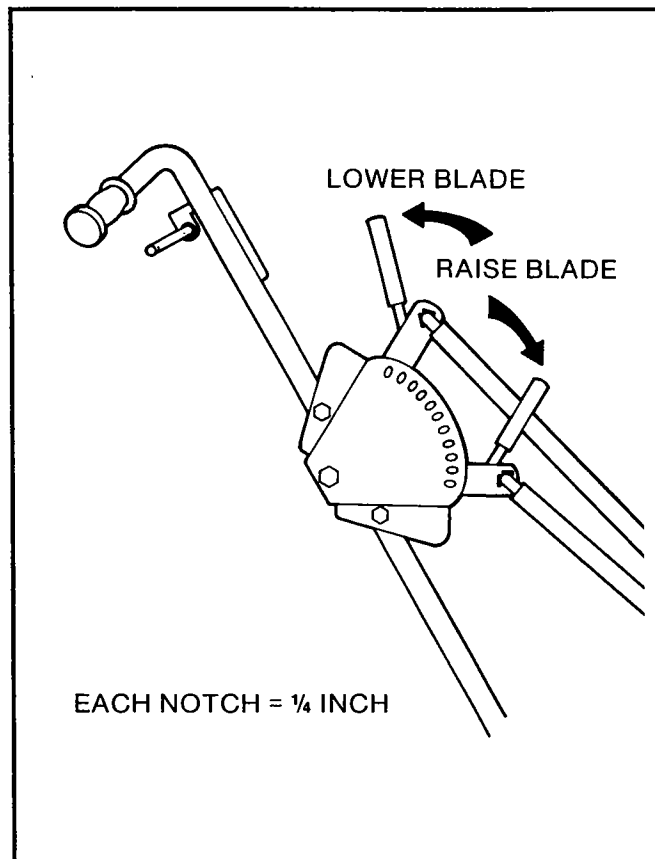

Figure 6

Operating Instructions

Figure 5 is a general view of the edger.

Note: Right or left side of the machine refers to the view from the normal operating position, behind the handles.

Before Routine Operation

1. Remove yellow oil fill cap and check oil level as detailed in engine operator's manual. Use SC class engine oil and change the grade, as temperature dictates (see table below).

Temperature	Up to 50°F (10°C)	Normal	Above 95°F (35°C)
Oil Viscosity	SAE 10W30	SAE 30	SAE 40

2. Before starting the engine, be sure the blade has a free arc of travel and blade is fully raised. Damage to blade can result if blade is not in the highest position (Figures 5 and 6).

Starting the Engine

Caution: Be sure no one is standing near blade. Keep body parts away from blade. Before starting, clear operating area of foreign objects, sticks, stones, etc.

1. If your edger has a *Kawasaki engine*, set RED engine stop switch to ON position. Choke and throttle levers are on the right side of the edger between the engine and the air cleaner (Figure 7).

If your edger has a *Briggs and Stratton engine*, the choke and throttle levers are on the right side of the edger below the air cleaner.

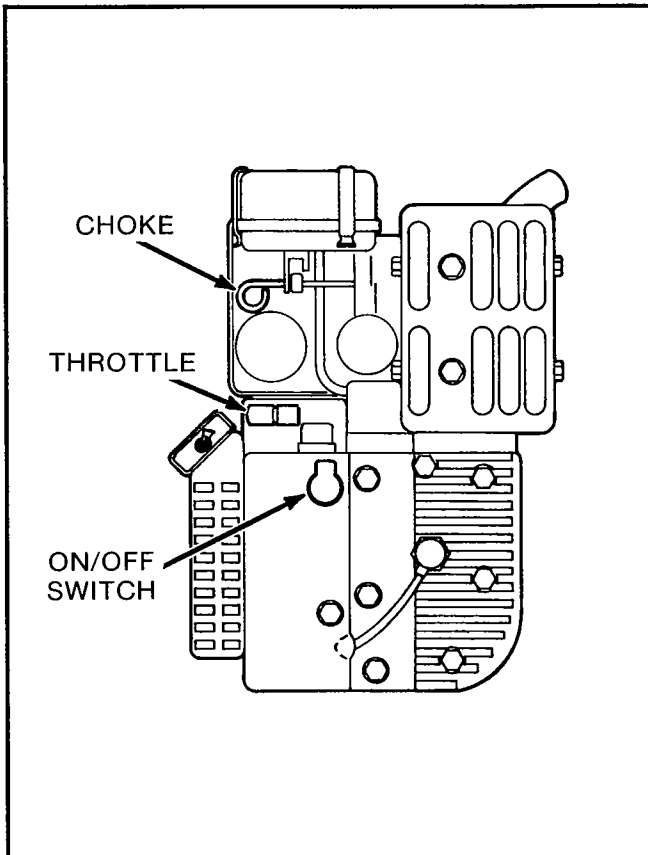

Figure 7

2. Push the choke lever all the way in to the closed position if engine is cold or open it half way to restart the engine.
3. Open throttle slightly.
4. Pull recoil handle out slowly until you feel compression, then allow handle to recoil and pull out fast.
5. If the engine does not start within three tries, turn the choke to the open position and try again. Too much fuel in the carburetor and cylinder may make engine starting difficult. Also check the engine stop switch. Make sure it is turned to ON.
6. Gradually open choke until engine runs smoothly. Allow the engine to run for three to five minutes to allow oil to circulate through the engine before adjusting the speed.

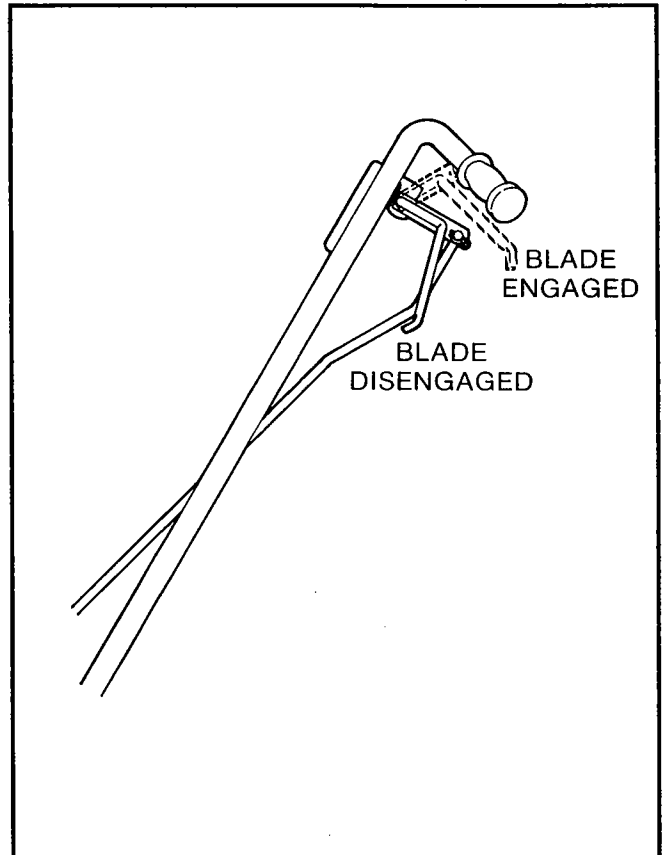

Figure 8

	<p style="text-align: center;">Danger</p> <p>Rotating blade is sharp. Keep hands and feet away from blade. Do not clean clippings from blade while blade is turning.</p>
--	---

Operation

1. Move edger to working area.
2. Pull operator presence safety levers up to engage blade (Figure 8) and carefully raise front wheel until the blade is at the desired cutting depth. When height adjustment lever is all the way forward the blade is 1/2 inch from the ground. Blade is lowered approximately 1/4 inch for each notch in the height adjustment index.
3. Push edger forward slowly, adjust pace to engine's capacity.

Maintenance

CAUTION: To prevent injury from rotating parts turn engine stop switch to OFF and disconnect spark plug wire from engine before attempting any maintenance.

Changing Engine Oil

Oil should be changed after first 20 hours of use and then after every 50 hours of use.

1. Start engine and allow it to warm up.
2. Turn engine switch to OFF. Make sure blade has stopped turning. Disconnect spark plug wire.
3. Carefully clean all debris from around oil filler cap.
4. Remove oil drain plug (Figure 9) and drain oil into an appropriate container.
5. After oil is drained, replace the drain plug and refill crankcase to level specified in engine owner's manual.
6. Replace oil level gauge.
7. Dispose of oil properly.

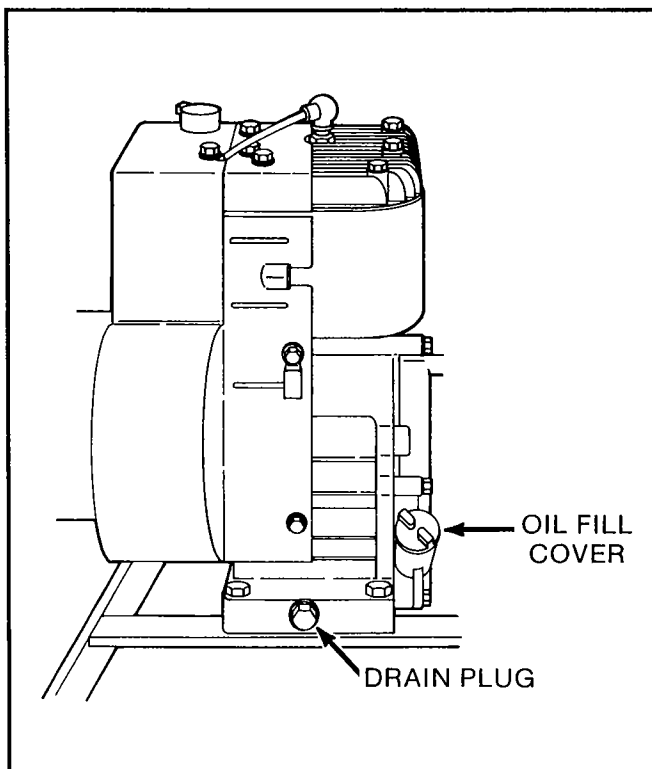

Figure 9

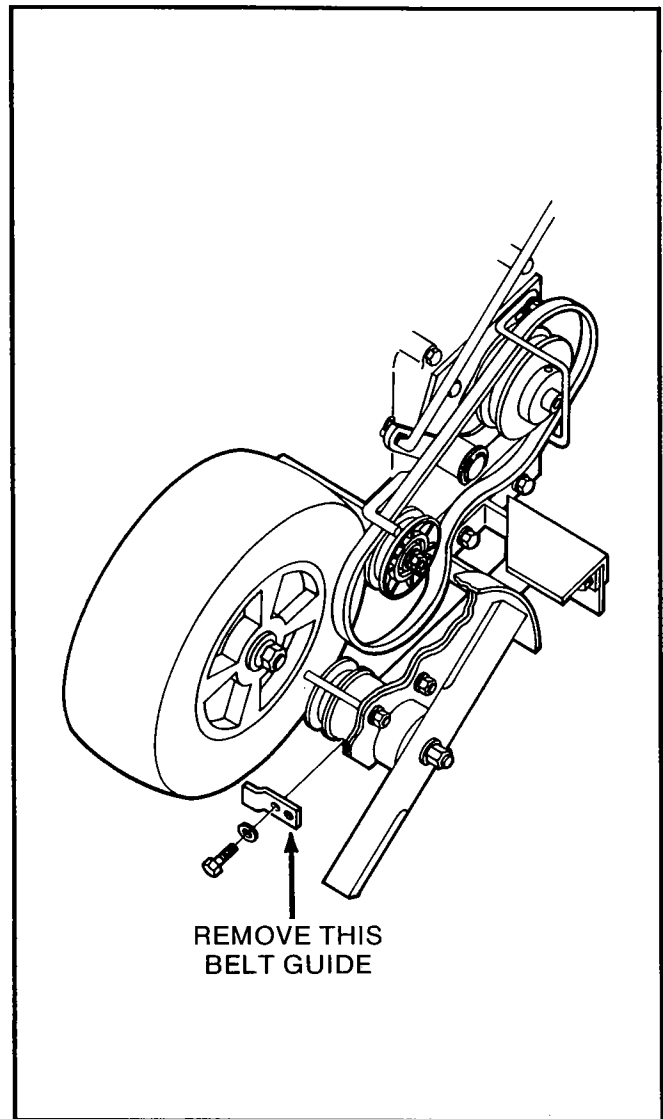

Figure 10

Changing the Belt

1. Remove flat bar belt guide at front of spindle boom assembly. (Figure 10).
2. Remove belt. Do not attempt to pry or force belt into or out of grooves as this may damage belts.
3. Replace belt.
4. Replace front belt guide.

Belt Tension

Always adjust belt tension after changing belt. New belts may stretch. Excess tension on belt will make holding clutch difficult and cause belts to wear.

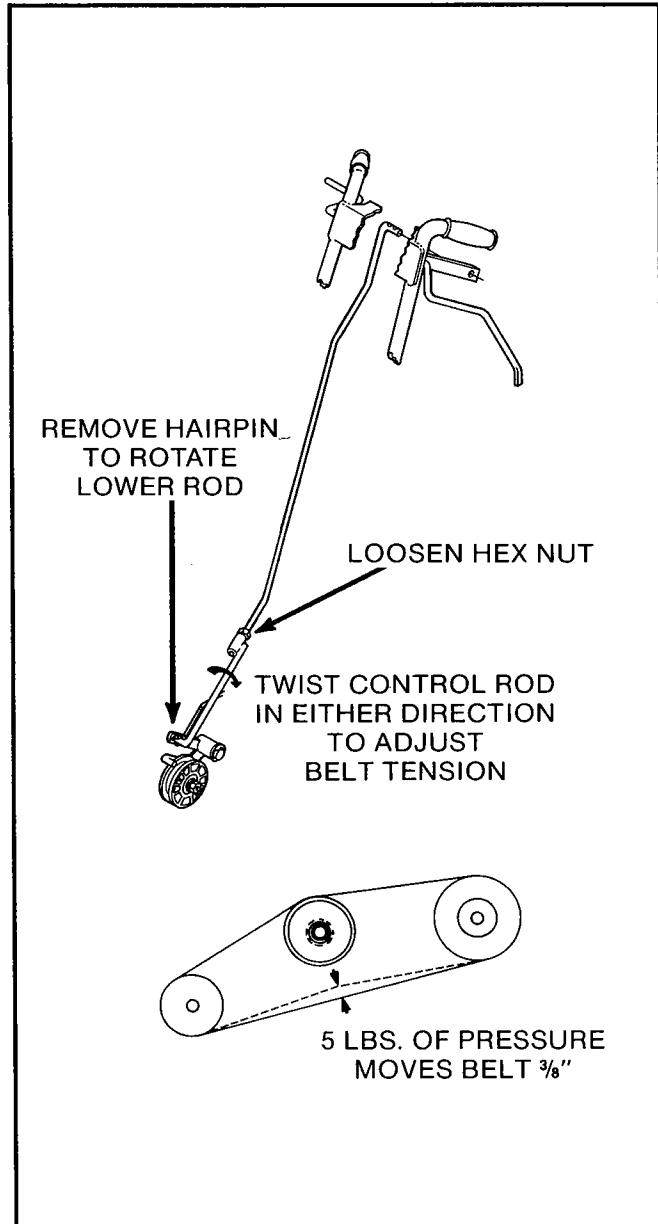

Figure 11

To adjust belt tension (see Figure 11):

1. Remove cotter pin from lower control rod and disconnect lower control rod from idler pulley assembly.
2. To increase tension, loosen hex nut and turn lower control rod to shorten rod. Retighten nut after rod is reinstalled.

Changing the Blade

Caution: Blade is sharp! Wear gloves when changing blade. Do not operate the edger with a damaged or excessively worn blade.

Note: Blades must be balanced before installation.

1. While holding hex nut on spindle pulley, remove nut and washer and carefully remove blade from assembly. (Figure 12)
2. Replace blade.
3. Replace nut and washer.
4. Tighten nut securely. Keep spindle shaft from rotating with wrench on hex nut located on pulley.

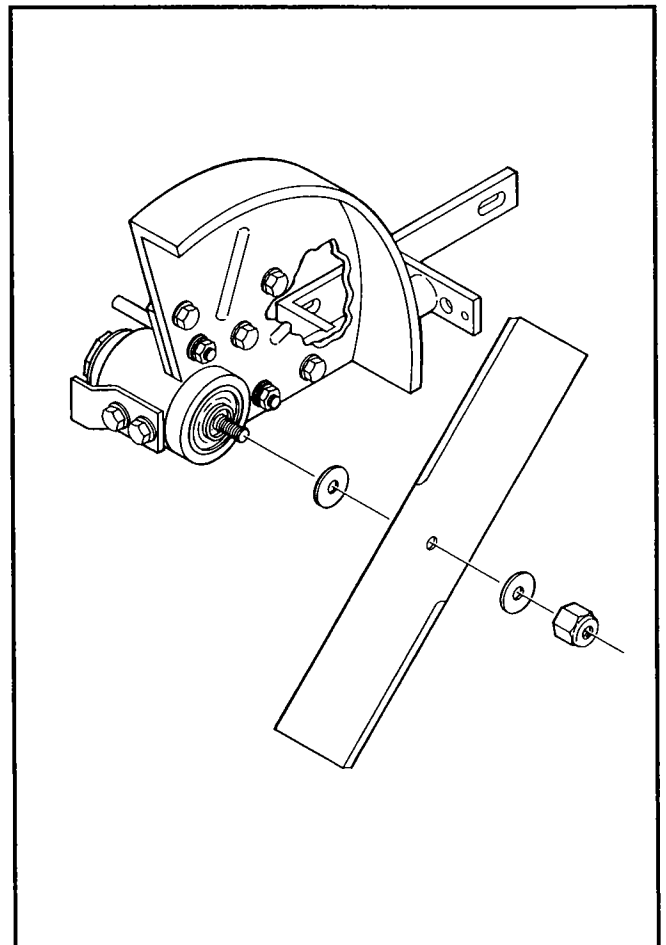

Figure 12

Rubber debris deflector

Replace rubber deflector when worn or damaged to prevent operator injury.

Cleaning the Air Filter

The air cleaner element should be cleaned every day. Under dusty condition, element should be cleaned more frequently.

If your edger has a Kawasaki engine: Snap cover off air cleaner assembly. Remove element, shake out, and wash in kerosene. Allow filter to dry. Reinstall the element in air cleaner body. Make sure that the surface marked **INSIDE** faces carburetor.

Note: Do not oil filter element.

If your edger has a Briggs and Stratton engine: Remove screw securing air cleaner assembly. Remove top cover. Remove element, shake out, and wash in kerosene then allow to dry. Re-install element in air cleaner body making sure that surface marked **INSIDE** faces carburetor.

Assembly

Periodically check that all bolts are tight, especially engine mounting bolts and blade guard mounting bolts.

Lubrication

Grease edger periodically at points shown on Figure 13. (use lithium based grease)

Note: The spindle bearings are sealed and permanently lubricated. They should require no maintenance.

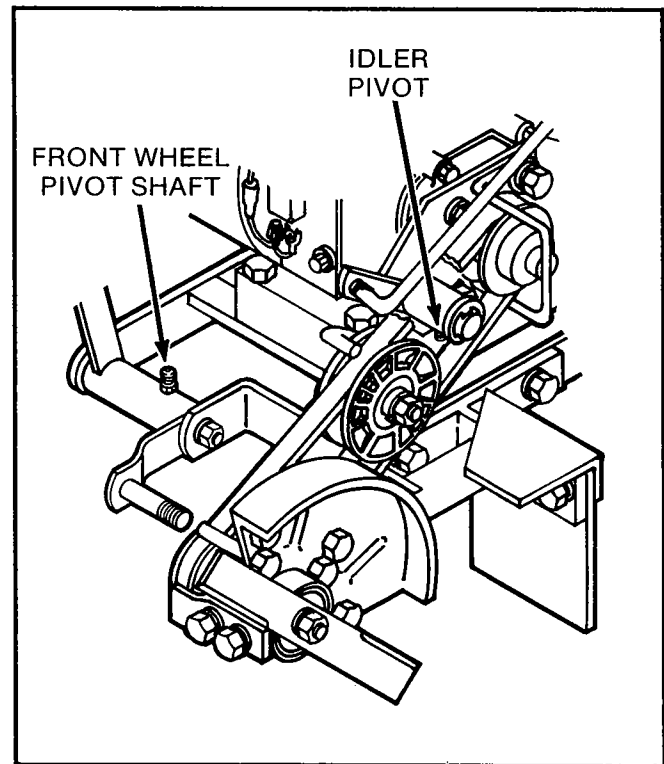

Figure 13

Troubleshooting Guide

Problem

Cause

Engine fails to start

Fuel level is low.
Spark plug lead wire disconnected.
Throttle or choke not in starting position.
Spark plug defective.
Carburetor improperly adjusted.
Old/stale gas.
Engine kill switch in off position.

Hard starting or loss of power

Carburetor improperly adjusted.
Spark plug wire loose.
Dirty air cleaner.

Operation erratic

Dirt in gas tank.
Dirty air cleaner.
Water in fuel supply.
Vent in gas cap and/or carburetor plugged.
Carburetor improperly adjusted.

Engine skips at high speed

Spark plug fouled, faulty, or gap too wide.
Carburetor improperly adjusted.
Dirty air cleaner.

Engine idles poorly

Carburetor idle speed too slow.
Carburetor improperly adjusted.
Spark plug gap too close.
Carburetor idle mixture improperly set.

LAWN EDGER

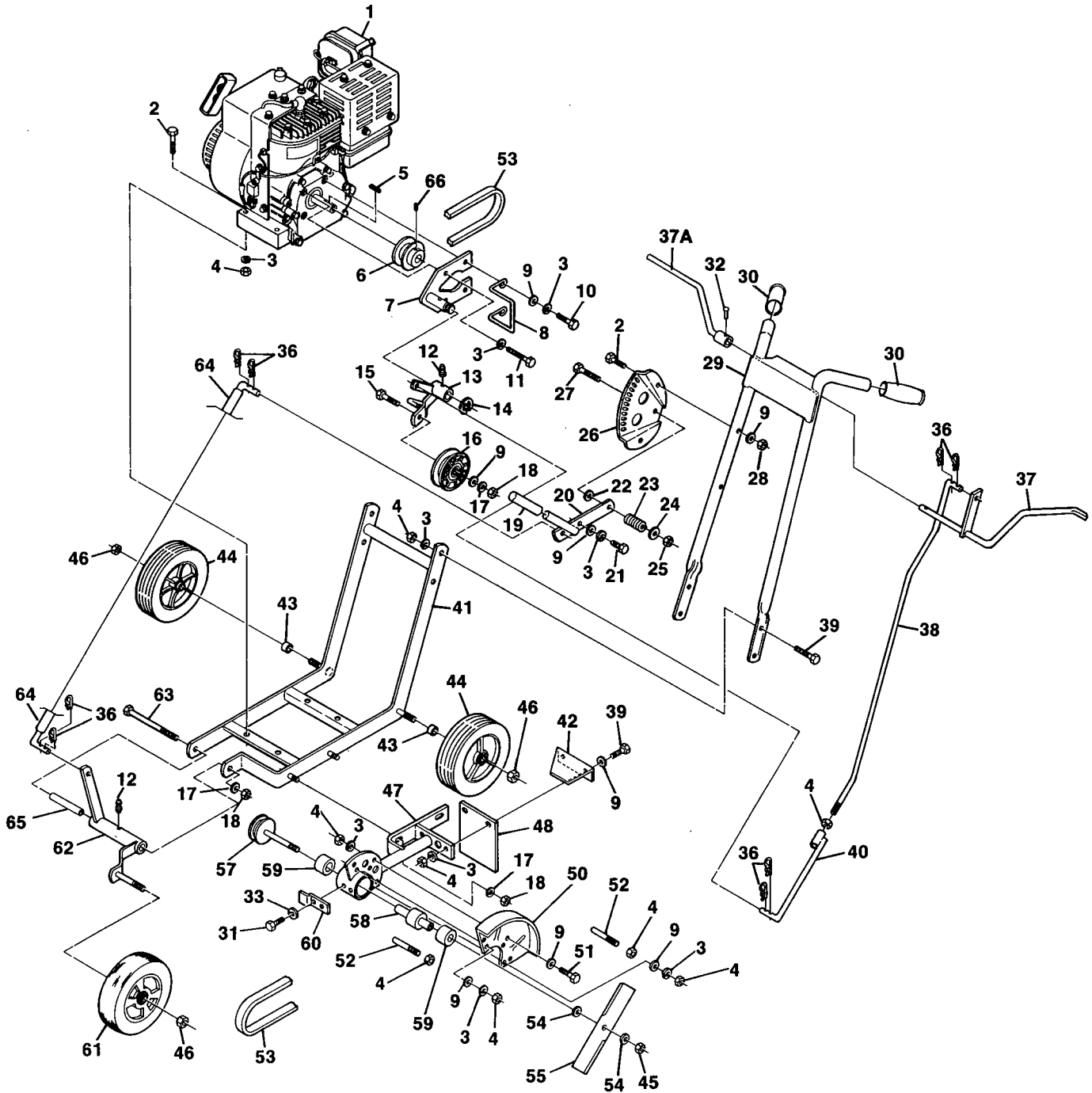

LAWN EDGER

REF.PART NO. NO.	DESCRIPTION	REF.PART NO. NO.	DESCRIPTION		
1	48449	Engine, 3.1 HP Kawasaki	33	*	Lockwasher, 1/4
1	48455	Engine, 3 HP Briggs & Stratton	36	04062-02	Hair Pin, Small
2	*	Bolt, Hex Hd, 5/16-18 x 1-1/2	37	45358	Lever, Operator, LH
3	*	Lockwasher, 5/16	37A	45359	Lever, Operator, RH
4	*	Hex Nut, 5/16-18	38	44039	Control Rod, Upper
5	04063-05	Key, 3/16 x 3/16 x 1-1/2	39	*	Bolt, Hex Hd., 5/16-18 x 1
6	48451	Pulley, Engine	40	45269	Control Rod, Lower
7	45291	Engine Adapter Bracket	41	45226	Engine Deck Frame
8	44048	Belt Guide, Engine	42	42591	Debris Guard
9	*	Flatwasher, 5/16	43	43141	Spacer, Rear Wheel
10	*	Bolt, Hex Hd, 5/16-24 x 1-1/4	44	48446	Wheel, Rear
11	*	Bolt, Hex Hd, 5/16-24 x 3/4	45	*	Hex Nut, 1/2-13
12	48114-04	Grease Fitting	47	45228	Spindle Boom
13	46321	Idler Pulley Arm Assy. (Includes bushings and grease fitting)	48	48453	Rubber Deflector
14	04050-02	Retaining Ring, 3/4" Ext "E"	49	*	Bolt, Hex Hd., 3/8-16 x 1
15	*	Bolt, Hex Hd, 3/8-16 x 1-1/2	50	46359	Blade Guard with Decal
16	48441	Pulley, Idler	51	*	Bolt, Hex Hd., 5/16-18 x 3/4
17	*	Lockwasher, 3/8	52	04004-11	Stud, 5/16-18 x 3 Grade 5
18	*	Hex Nut, 3/8-16	53	48452	Pulley, Spindle
19	48144	Grip	54	*	Flat Washer, 0.500 x 1.250 x 0.0832
20	45229	Height Adjustment Lever	55	48444	Blade
21	43147	Index Pin	57	45342	Pulley, Spindle
22	04041-10	Flat Washer, 3/8 x 2 x 16 ga.	58	43139	Bushing
23	48050	Spring	59	48442	Bearing, Spindle
24	*	Flat Washer, 25/64 x 15/16 x 12 ga.	60	42584	Belt Guide
25	*	Hex Nut, 3/8-16 x 1-3/4	61	48440	Wheel, Front
26	42595	Height Adjustment Index	62	45231	Front Wheel Bracket
27	*	Bolt, Hex Hd, 3/8-16 x 1-3/4	63	*	Bolt, Hex Hd., 3/8-16 x 5
28	*	Hex Nut, 5/16-18 Elastic Stop	64	45288	Control Rod, Wheel Height Adjustment
29	46381	Handle Assembly (includes grips)	65	43138	Sleeve
30	48448	Grip	66	*	Setscrew, 5/16-18 x 1/4
31	*	Bolt, Hex Hd., 1/4-20 x 1/2	NS	48447	Decal, Warning
32	04060-01	Roll Pin, 5/32 x 3/4	NS	48454	Decal, Scag Edger

*Common hardware which should be purchased locally. All bolts Grade 5 plated. All other fasteners are zinc plated.

WARNING

If incorrectly used, this machine can cause severe injury. Those who use and maintain the machine should be trained in its proper use, warned of its dangers, and should read the entire manual before attempting to set up, operate, adjust or service this machine.

LIMITED WARRANTY-COMMERCIAL EQUIPMENT

Any part of the Scag commercial edger manufactured by Scag and found, in the reasonable judgment of Scag, to be defective in material or workmanship, will be repaired or replaced by an Authorized Scag Service Dealer without charge for parts or labor.

The Scag edger including any defective part must be returned to an Authorized Scag Service Dealer within the warranty period. The expense of delivering the edger to the dealer for warranty work and the expense of returning it to the owner after repair or replacement will be paid for by the owner. Scag's responsibility in respect to claims is limited to making the required repairs or replacements, and no claim of breach of warranty shall be cause for cancellation or rescission of the contract of sale of any Scag edger. Proof of purchase will be required by the dealer to substantiate any warranty claim. All warranty work must be performed by an Authorized Scag Service Dealer.

This warranty is limited to ninety (90) days from the date of original retail purchase for any Scag edger that is used for commercial or rental purposes. Any Scag edger used for private residential use will be warranted for one (1) full year from date of original retail purchase.

This warranty does not cover an edger that has been subject to misuse, neglect, negligence, or accident, or that has been operated in any way contrary to the operating instructions as specified in the Technical Manual. The warranty does not apply to any damage to the edger that is the result of improper maintenance, or to any edger or parts that have not been assembled or installed as specified in the Technical Manual.

This warranty does not cover an edger that has been altered or modified. In addition, the warranty does not extend to repairs made necessary by normal wear, or by the use of parts or accessories which, in the reasonable

judgement of Scag, are either incompatible with the Scag edger or adversely affect its operation, performance, or durability. This warranty does not cover engines and electric starters, which are warranted separately by their manufacturer.

Scag Power Equipment reserves the right to change or improve the design of the edger without assuming any obligation to modify any edger previously manufactured.

All other implied warranties are limited in duration to the ninety (90) day warranty period or one (1) year private residential use. Accordingly, any such implied warranties including merchantability, fitness for particular purpose, or otherwise, are disclaimed in their entirety after the expiration of the appropriate forty-five day or one year warranty period. Scag's obligation under this warranty is strictly limited to the repair or replacement of any defective parts and Scag does not assume or authorize anyone to assume for them any other obligation. Some states do not allow limitations on how long an implied warranty lasts, so the above limitation may not apply to you.

Scag assumes no responsibility for incidental, consequential or other damages including, but not limited to, expense for gasoline, expense of delivering the edger to an Authorized Scag Service Dealer and expense of returning.

PLEASE BE CAREFUL

1. Keep all shields in place.
2. Stop machine and remove spark plug wire to adjust or service.
3. When mechanism becomes clogged, stop engine before cleaning.
4. Keep hands, feet, and clothing away from power drive parts.
5. Keep off implement unless seat or platform is provided.
6. Keep others off.

FAILURE TO FOLLOW CAUTIOUS OPERATING PRACTICES MAY RESULT IN SERIOUS BODILY INJURY. BESIDES, WE WOULD LIKE YOU TO CONTINUE TO ENJOY AND PROFIT BY USING OUR PRODUCTS.

OWNER REFERENCE

MODEL NUMBER _____

SERIAL NUMBER _____

ENGINE MODEL _____

SERIAL NUMBER _____