

SCAG[®]

POWER EQUIPMENT

OPERATOR'S MANUAL

SVRII

GRASS CATCHER

Model: GC-VR11



This manual contains the operating instructions and safety information for your Scag mower accessory. Reading this manual can provide you with assistance in maintenance and adjustment procedures to keep your mower accessory performing to maximum efficiency. The specific models that this book covers are listed on the inside cover. Before operating your machine, please read all the information enclosed.



WARNING

FAILURE TO FOLLOW SAFE OPERATING PRACTICES MAY RESULT IN SERIOUS INJURY OR DEATH.

- Read this manual completely as well as other manuals that came with your mower.
- DO NOT operate on steep slopes.
- Under no circumstances should the machine be operated on slopes greater than 20 degrees. ALWAYS FOLLOW OSHA APPROVED OPERATION.
- Stay two cut widths away from slopes, drop offs, ditches and retaining walls.
- DO NOT mow on wet grass. Wet grass reduces traction and steering control.
- Keep all shields in place, especially the grass discharge chute.
- Before performing any maintenance or service, stop the machine and remove the spark plug wire and ignition key.
- If a mechanism becomes clogged, stop the engine before cleaning.
- Keep hands, feet and clothing away from power-driven parts.
- Keep others off the mower (only one person at a time)

REMEMBER - YOUR MOWER IS ONLY AS SAFE AS THE OPERATOR!

HAZARD CONTROL AND ACCIDENT PREVENTION ARE DEPENDENT UPON THE AWARENESS, CONCERN, PRUDENCE, AND PROPER TRAINING OF THE PERSONNEL INVOLVED IN THE OPERATION, TRANSPORT, MAINTENANCE, AND STORAGE OF THE EQUIPMENT.

This manual covers the operating instructions and illustrated parts list for:

GC-VR11

with a serial number of

P6200001 to P6299999

Always use the entire serial number listed on the serial number tag when referring to this product.

GENERAL INFORMATION

1.1 INTRODUCTION

This manual has been prepared to provide the information you need to correctly assemble, operate, and maintain this grass catcher. Read it carefully and keep it for future reference.

THE REPLACEMENT OF ANY PART ON THIS PRODUCT BY OTHER THAN THE MANUFACTURER'S AUTHORIZED REPLACEMENT PART MAY ADVERSELY AFFECT THE PERFORMANCE, DURABILITY OR SAFETY OF THIS PRODUCT.

USE OF OTHER THAN ORIGINAL SCAG REPLACEMENT PARTS WILL VOID THE WARRANTY.

If additional information or service is needed that is not outlined in this manual, please contact your Scag Power Equipment dealer. Scag dealers are trained in the latest service methods and carry a full line of Scag replacement parts.

When ordering parts, always provide the complete model number and serial number of your catcher.

All information provided in this manual is based upon information available at the time of printing. Scag Power Equipment reserves the right to make changes at any time without notice or obligation.

1.2 DIRECTION REFERENCE

The "Right" and "Left", "Front" and "Rear" of the machine are referenced from the operator's right and left when standing in the normal operating position and facing the forward travel direction.

1.3 SAFETY AND OPERATING INSTRUCTIONS

NOTE -

To avoid personal injury, it is imperative that all safety instructions be observed.

1. Read this operator's manual and the operator's manual that is supplied with the machine this attachment is used on.

A replacement manual is available from your authorized Scag Service Dealer or by contacting: Scag Power Equipment, Service Department at P.O. Box 152, Mayville, WI 53050. You may also contact us through our website at www.scag.com. The manual for this grass catcher can be downloaded by using the model and serial number or use the contact form to make your request. Please indicate the complete model and serial number of your Scag product when requesting replacement manuals.

WARNING

Do not operate without discharge chute, mulch kit, operator controlled discharge chute (OCDC), or entire grass catcher installed.

2. Before removing the grass bags, disengage the mower, stop the engine and wait for all movement to stop.
3. **ALWAYS** turn the engine **OFF**, remove the key and wait for all movement to stop before servicing or cleaning the mower or the grass catcher.

DANGER



**ROTATING BLOWER
BLADES
STOP ENGINE BEFORE
ENTERING CHUTE
CONTACT CAN INJURE**

4. Do not modify or alter any component of the grass catcher attachment or mower.
5. Do not allow any passengers to ride on the grass catcher attachment or on the mower.

2.1 ASSEMBLY INSTRUCTIONS - CUTTER DECK AND BLOWER COMPONENTS

- NOTE -

Use the illustrated parts list as a part number reference when following the assembly instructions.

-IMPORTANT-

When installing this grass catcher on a machine, one of the following Installation Kits will be needed to complete the installation.

- SVRII-48V - Installation Kit p/n 901M
- SVRII-52V - Installation Kit p/n 901N
- SVRII-61V - Installation Kit p/n 901P

-NOTE-

When installing this catcher on a model with serial numbers M9500001-N0199999, a new rear belt cover (p/n 427917) will need to be ordered and installed to provide clearance for the mounting bracket.

1. Remove all packaging materials. Lay out the mounting hardware and the catcher assembly parts for easy access. Prepare the work area making sure that it is a clean and safe environment.



WARNING

Do not operate without discharge chute, mulch kit, operator controlled discharge chute (OCDC), or entire grass catcher installed.

2. Remove the discharge chute from the cutter deck. See Figure 2-2.

- NOTE -

Do not discard the discharge chute or mounting hardware. The discharge chute **MUST** be reinstalled any time the grass catcher has been removed from the machine.

3. Remove the right side belt cover to gain access to the spindle assembly. See Figure 2-2.

- NOTE -

Retain the original belt cover. This cover **MUST** be reinstalled any time the complete catcher system is removed.

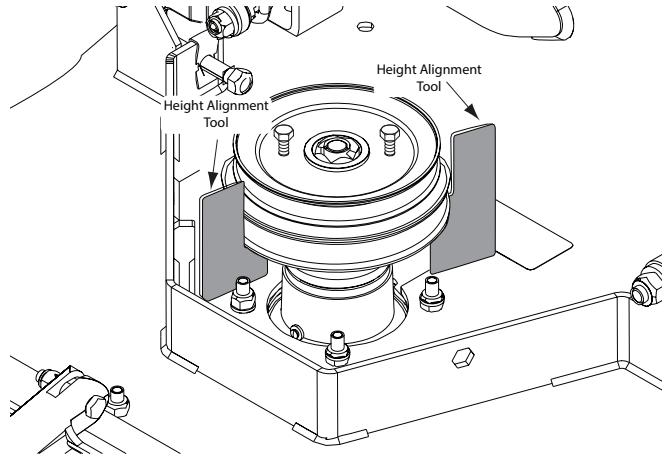

Figure 2-1. Height Alignment Tools

4. Remove the belt and install the grass catcher pulley onto the spindle assembly. Make sure to mount the pulley 3" from the top of the deck support plate to the center of the groove of the bottom pulley (use the height alignment tools, included with this kit, for increased accuracy, p/n 428125, See Figure 2-1). Install the pulley with the hub inverted, using 1/4-20 x 2 1/2" bolts (p/n 04001-225). See Figure 2-2. (The height alignment tools may "push out" as the pulley is tightened to the hub, this is normal)

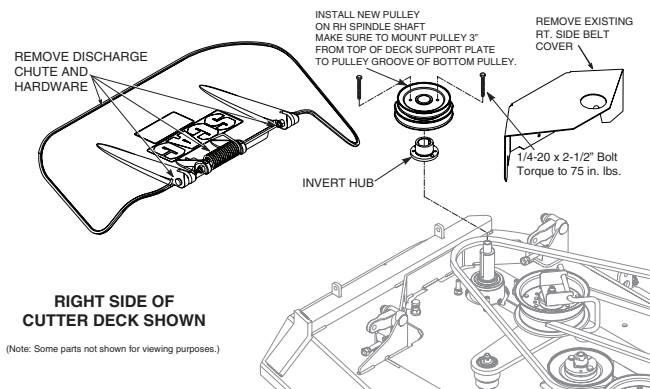

Figure 2-2. Discharge Chute Removal

5. Remove the turbo baffle from the cutter deck. Using 5/16-18 x 1" bolts (p/n 04001-09), 5/16 flatwasher (p/n 04040-15), and 5/16 elastic stop nuts (p/n 04021-10) install the catcher turbo baffle. See Figure 2-3. (baffles have p/n's on them)

Section 2

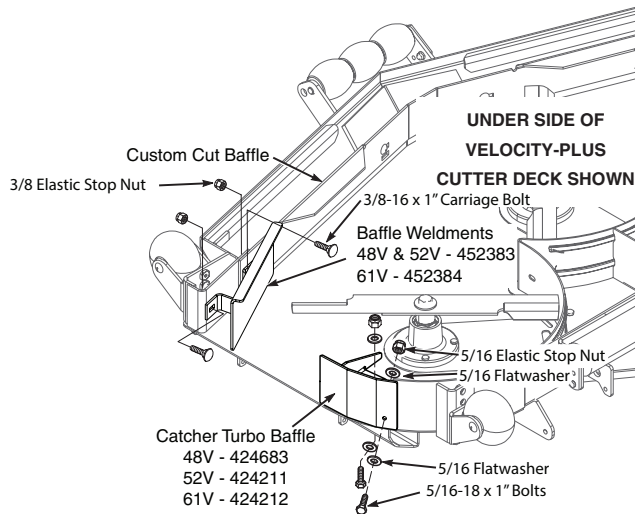

Figure 2-3. Grass Catcher Baffles

- NOTE -

Do not discard the original turbo baffle. This baffle may be reinstalled any time the grass catcher has been removed from the machine.

- Remove the hardware for the custom cut baffle from the mounting hole closest to the discharge opening.
- Install the grass catcher baffle weldment and secure using 3/8-16 x 1" carriage bolts (p/n 04003-23) and 3/8-16 elastic stop nuts (p/n 04021-09). See Figure 2-3.

-NOTE-

Adjust the "Custom-Cut" baffle installed in the cutter deck to the lowest position to enhance grass catcher performance.

- Install the blower mounting post to the deck using 3/8-16 x 1 1/4" bolts (p/n 04001-32), 3/8 flatwashers (p/n 04041-07), 3/8 lockwasher (p/n 04030-04), and 3/8-16 elastic stop nut (p/n 04021-09). Do not fully tighten the hardware at this time. See Figure 2-4 through Figure 2-6.

- NOTE -

When installing on serial numbers M9500001-N0199999 and N61xxxxx models, one hole for the 48V mounting post bracket may need to be drilled. Use the mounting post bracket as a guide if a hole needs to be drilled.

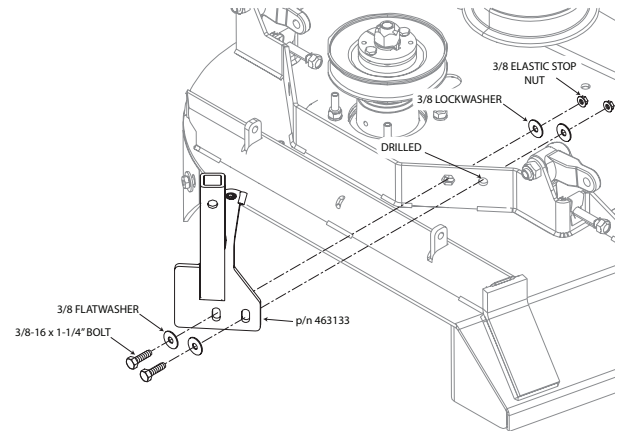

Figure 2-4. Blower Mounting Post Installation (48V)

- NOTE -

When installing on serial numbers M9500001-N0199999, N62xxxxx, and N63xxxxx; all holes for the 52V mounting post bracket may need to be drilled. Use the template (p/n 427979), included, if holes need to be drilled.

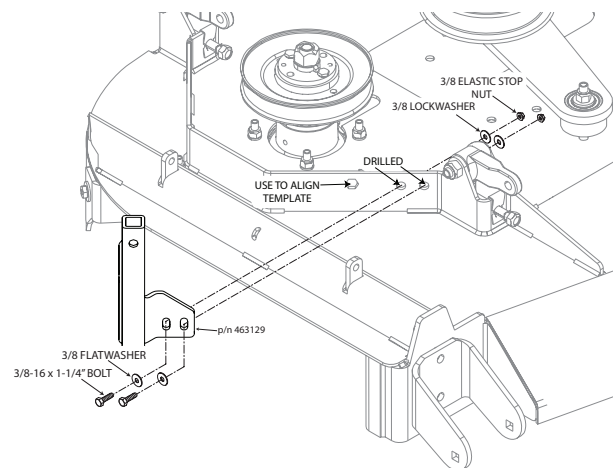

Figure 2-5. Blower Mounting Post Installation (52V)

- NOTE -

When installing on serial numbers M9500001-N0199999, N64xxxxx, and N65xxxxx; one hole for the 61V mounting post bracket may need to be drilled. Use the mounting post bracket as a guide if a hole needs to be drilled.

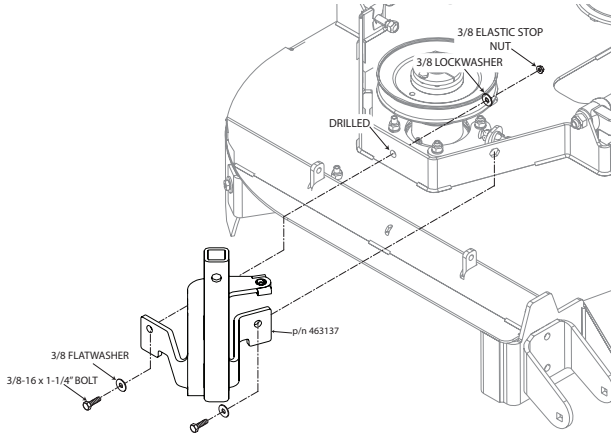

Figure 2-6. Blower Mounting Post Installation (61V)

9. Install the blower assembly to the mounting bracket and secure with the mounting pin. See Figure 2-7.
10. Align the blower assembly with the discharge opening of the cutter deck. Tighten the hardware for the mounting bracket. See Figure 2-7.
11. Install the quick pin through the hole in the front discharge chute mounting bracket. See Figure 2-7.

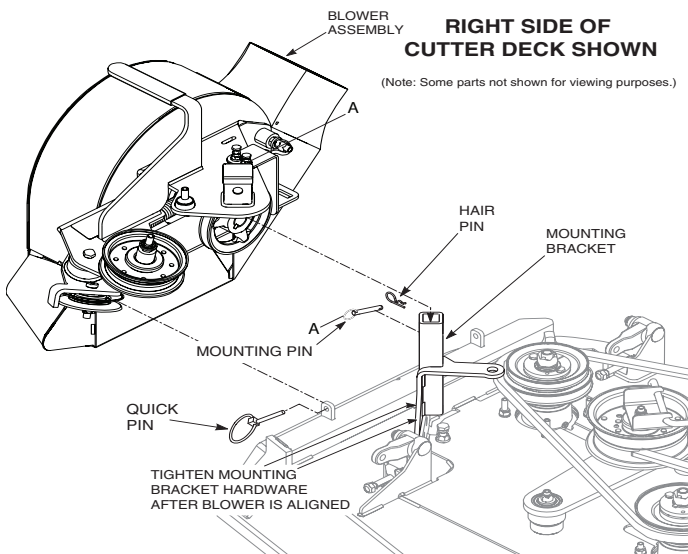

Figure 2-7. Blower Installation

12. Install the belt to the spindle pulley. When replacing the belt. See Figure 2-8 for belt routing.

-NOTE-

May need to loosen the rear belt cover guard to route belt around the blower pulley.

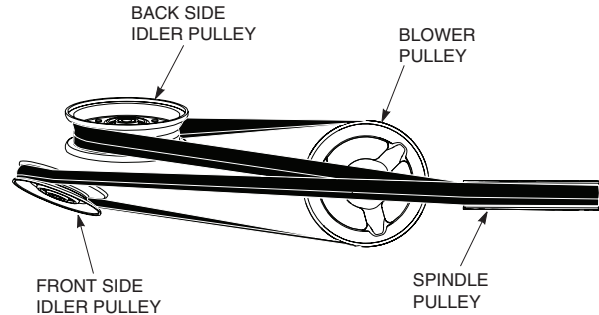

Figure 2-8. Belt Routing

13. Install the new belt covers supplied and secure. See pages 10-13 of the illustrated parts section provided in this manual for proper installation.

2.2 ASSEMBLY INSTRUCTIONS - HOPPER COMPONENTS

14. With help from an assistant, install the grass catcher mounting weldment assembly. See Figure 2-9 and 2-10.

-NOTE-

For models M9500001-N0199999 and N61xxxxx-N65xxxxx, the bottom hole for the side mounting bracket to the frame may need to be drilled. Use the mounting bracket as a guide if a hole needs to be drilled.

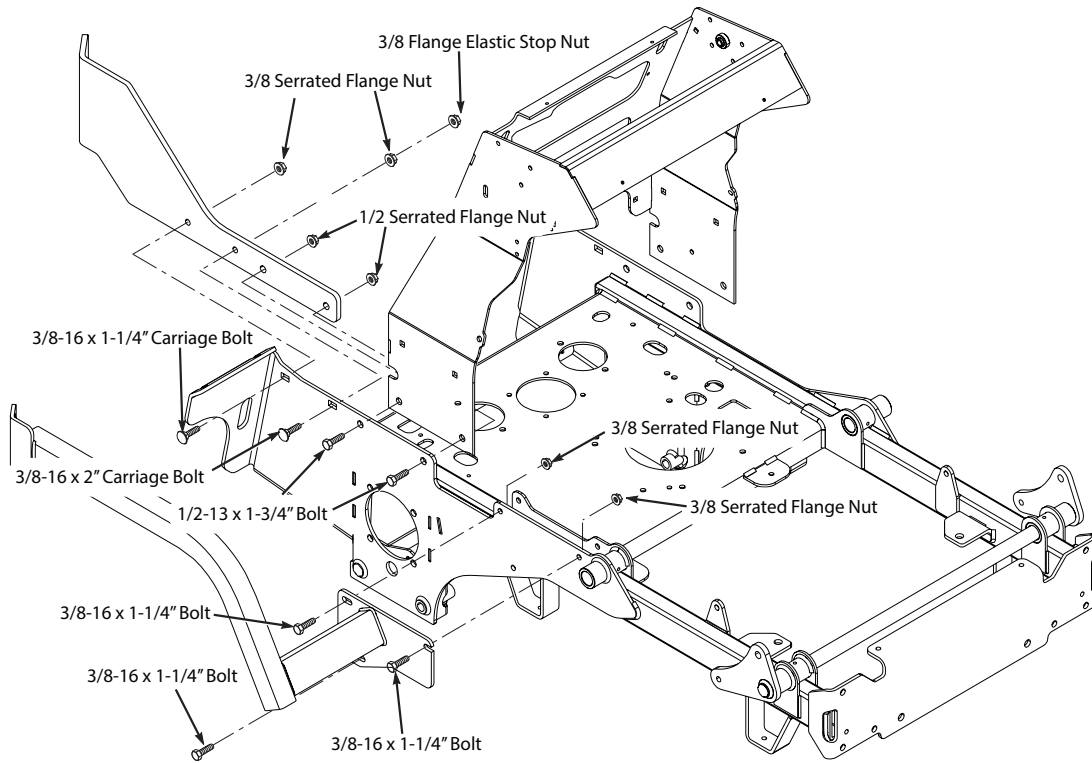

Figure 2-9. Mounting Weldment Assembly

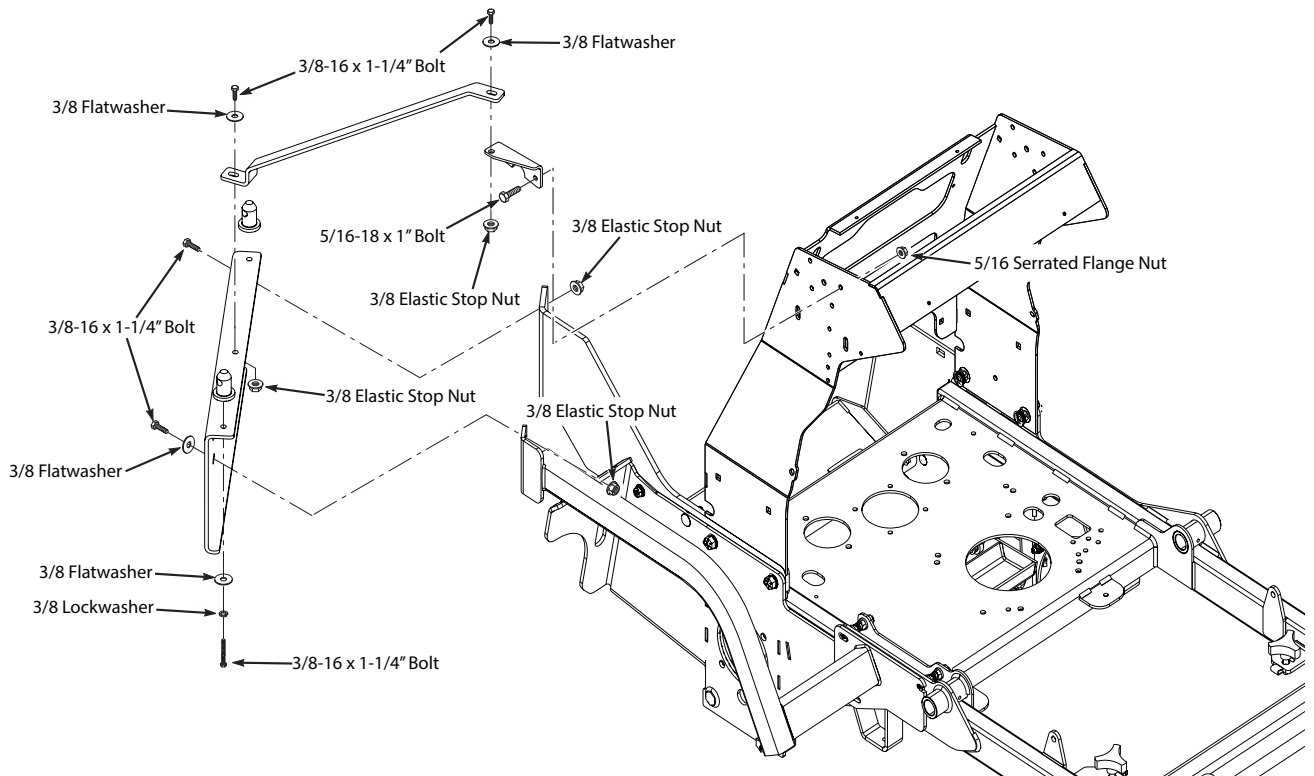

Figure 2-10. Mounting Weldment Assembly

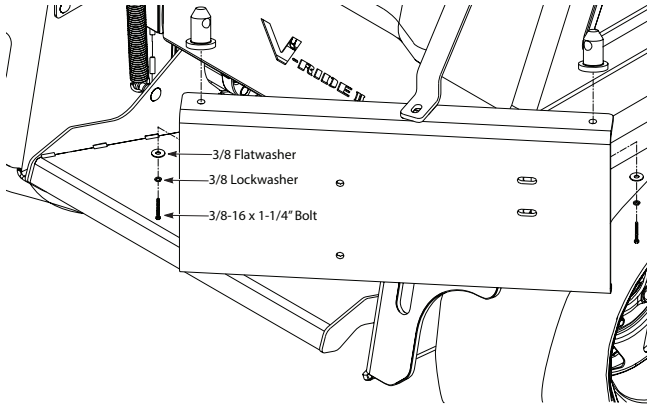

Figure 2-11. Hopper Mounting Hardware Install

15. Install the mounting pins on to the rear of the machine as shown. Secure using the hardware provided. See Figure 2-11. Note pin alignment in Figure 2-11 and Figure 2-12. This will allow for proper snap pin installation.

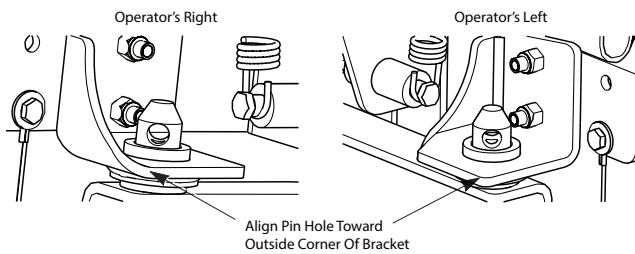

Figure 2-12. Pin Alignment

16. With help from an assistant, install the hopper assembly to the machine and secure with the ring pins. See Figure 2-13.

-NOTE-

The model shown in Figure 2-13 is for reference only. The grass catcher installs to all models in a similar fashion.

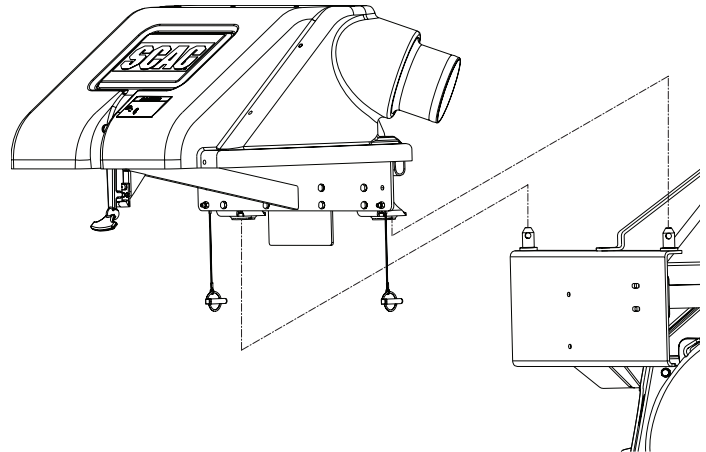

Figure 2-13. Hopper Installation

17. Install hose adapter (p/n 461387) to the blower assembly and secure with the strap.

-NOTE-

When installing this catcher the discharge hose may need to be shortened. Follow the steps below when required.

18. Lower the cutter deck on the machine to the lowest cutting height.
19. If required, shorten the hose assembly before securing it to the hood assembly. Route the hose up to the hood assembly and mark the hose length required which will not allow the hose to "sag" or "droop".
20. Cut the hose to the required length, if needed.
21. Install the hose from the blower assembly to the hopper hood. Secure using the 6" clamps.
22. Install the bag assemblies.

2.3 ASSEMBLY INSTRUCTIONS - FRONT WEIGHT COMPONENTS

1. Assemble the front weight bar as shown in Figure 2-14.
2. Using the weight support bar as a guide, identify the corresponding mounting holes used to secure the weight support bar to the front of the machine as shown in Figures 2-14.

For all SVRII models, existing hardware will need to be removed in order to secure the weight support bar to the front of the machine.

Section 2

3. Install the weight onto the weight bar. Slide the weight to the operator's far left side of the machine, secure using the pin (p/n 485172) in the hole to the inside of the weight. See Page 21 for the correct number of weights required.
4. Check all hardware for tightness.
5. Operate and test.

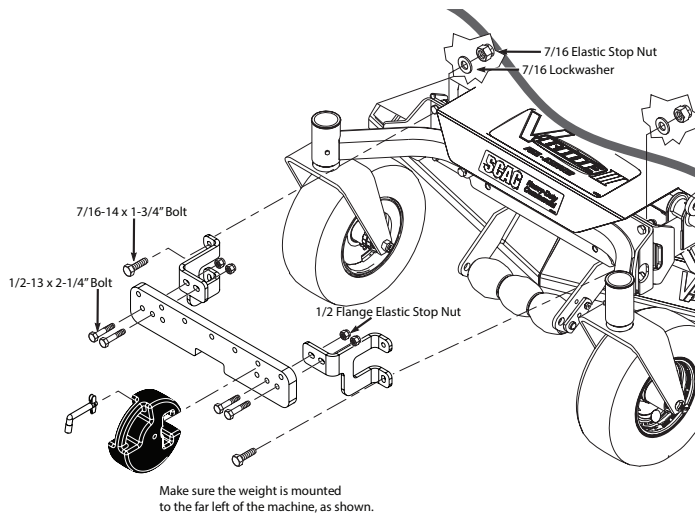

Figure 2-14. Front Weight Bar Installation

3.1 GRASS CATCHER REMOVAL INSTRUCTIONS

Prepare the machine so there is easy and safe access to the work area. Park the machine on a flat, level surface and apply the parking brake. Remove the ignition key and disconnect the positive and negative cables from the battery. Maintain all safety related work procedures. Always wear hand and eye protection.

- NOTE -

For best overall performance and dispersal of grass clippings while side discharging, the grass catcher discharge baffle should be removed and the original turbo baffle should be reinstalled.

1. Remove the rubber strap holding the adapter to the blower assembly and the large quick pin securing the blower to the discharge mounting bracket. See Figure 3-1.
2. Remove the belt, pin, hair pin and large quick pin securing the blower assembly to the cutter deck and remove the blower assembly. See Figure 3-1.

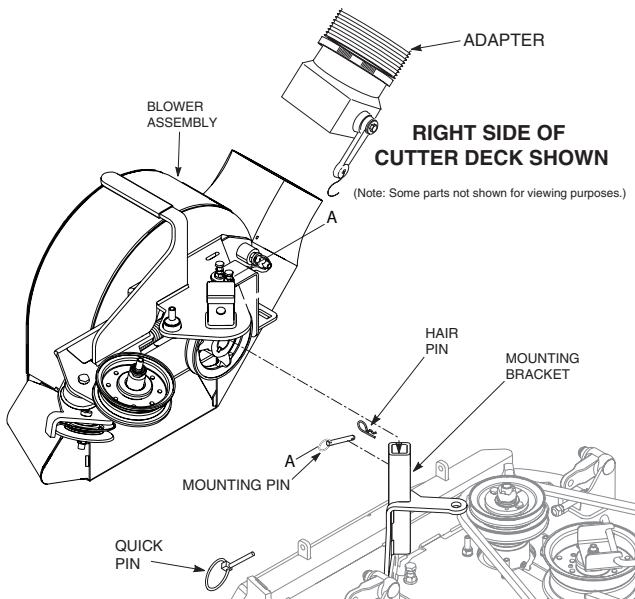

Figure 3-1. Removing the Blower Assembly

3. Remove the ring pins securing the hopper assembly to the rear of the machine.
4. With help from an assistant, remove the hopper assembly.

WARNING

Do not operate without discharge chute, mulch kit, operator controlled discharge chute (OCDCh), or entire grass catcher installed.

5. Re-install the side discharge chute to the opening on the cutter deck. Replace the two (2) outside mounting bolts on the discharge chute with the clevis pins (p/n 04064-15) and rue cotter pins (p/n 04069-03). See Figure 3-2.
6. Re-install the cutter deck belt cover.
7. Remove the weights from the weight bar.

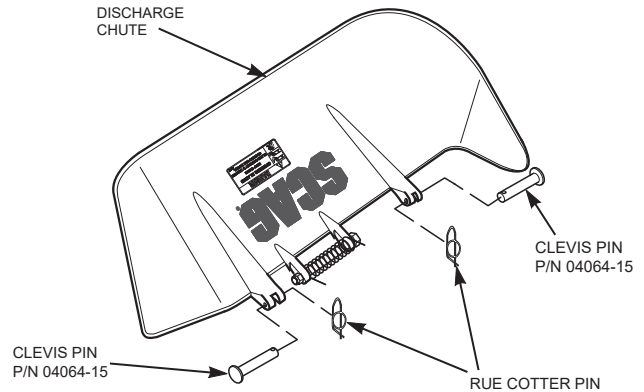

Figure 3-2. Reinstalling the Discharge Chute

MAINTENANCE

4.1 MAINTENANCE CHART - RECOMMENDED SERVICE INTERVALS

Break-In (First 10)	HOURS						Procedure	Comments
	8	20	40	100	200	500		
X							Check all hardware for tightness	
X							Inspect hose and adapter	
X							Check belt for proper alignment	
X							Inspect fabric bags	
	X						*Check screen in hopper	Remove debris from screen
	X						Inspect hose and adapter	
	X						Inspect fabric bags	
	X						Check condition of blower	
	X						*Apply grease to blower bearings	See figure below
		X					Check belt for proper alignment	

* Perform these maintenance procedures more frequently under extreme dusty or dirty conditions.

GREASE FITTING
ON BEARING HOUSING

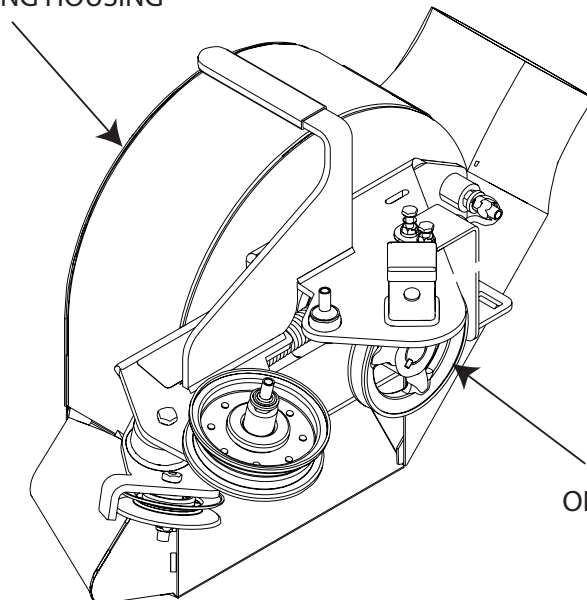

GREASE FITTING
ON BEARING HOUSING
BEHIND PULLEY

ILLUSTRATED PARTS LIST

5.1 SCAG APPROVED ATTACHMENTS AND ACCESSORIES

Attachments and accessories manufactured by companies other than Scag Power Equipment are not approved for use on this machine.

GC-VRII BLOWER HOUSING ASSEMBLY

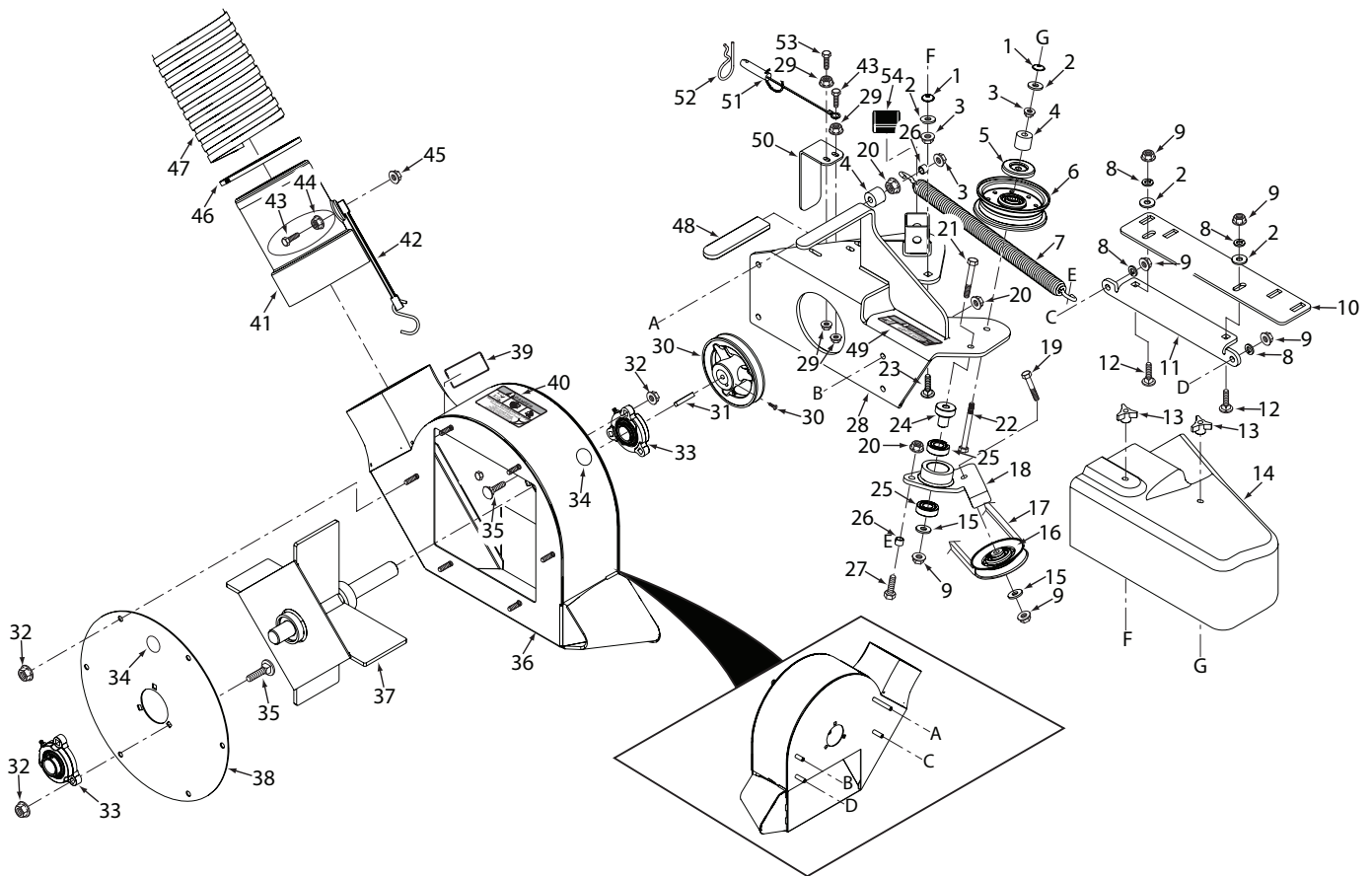

GC-VRII BLOWER HOUSING ASSEMBLY

Ref. No.	Part No.	Description	Ref. No.	Part No.	Description
1	04024-02	Nut, Push-On - 3/8	41	461387	Adapter, With Strap Assembly (INCL. 42,43,44,45)
2	04041-07	Washer, Flat, 3/8, .391 x .938 x .105	42	48137-04	Rubber Strap 7 $\frac{3}{4}$ "
3	04021-05	Nut, Lock, Center Lock, 3/8-16	43	04001-59	Bolt, 1/4-20 x 1 $\frac{1}{4}$ "
4	43277	Spacer, J-Pull Rod	44	04040-14	Washer, Flat 1/4, .312 x .750 x .065
5	424367	Dust Shield	45	04021-08	Nut, Lock, Elastic Stop, 1/4-20
6	483209	Pulley, 4" Idler	46	48136-18	Clamp, Hose - 6" OD
7	481522	Spring, Main Drive	47	48135-59	Hose, 6" x 36" Long
8	04030-04	Washer, Lock, 3/8 Spring	48	481428	Grip, Blower Gate Lever
9	04021-09	Nut, Lock, Elastic Stop, 3/8-16	49	483402	Decal, Belt Cover
10	427387	Plate, Blower Catch	50	427331	Belt Cover, Rear
11	423296	Plate, Catch Mounting	51	04067-10	Pin, Ring .5 x 2 $\frac{1}{4}$ "
12	04003-11	Bolt, Carriage, 3/8-16 x 1 $\frac{1}{4}$ "	52	04062-04	Hair Pin Cotter, .177 x 3 $\frac{1}{4}$ "
13	04029-04	Wingnut, 3/8 Plastic - Small	53	04001-04	Bolt, 1/4-20 x 1 $\frac{1}{2}$ "
14	486348	Belt Cover, 48GC-VRII	54	482300	Cap, Square Vinyl
	486349	Belt Cover, 52GC-VRII			
	486350	Belt Cover, 61GC-VRII			
15	04043-04	Washer, Flat Hardened, 3/8, .391 x .938 x .105			
16	483189	Pulley, 3.5 OD V-Idler			
17	482379	Belt (48 and 52)			
	483182	Belt (61)			
18	493215	Idler Arm Assembly, 48/52GC-VRII (INCL. 9,15,16,17,19,20,25,26,27)			
	493217	Idler Arm Assembly, 61GC-VRII (INCL. 9,15,16,17,19,20,25,26,27)			
19	04001-45	Bolt, 3/8-16 x 2"			
20	04019-04	Nut, Serrated Flange, 3/8-16			
21	04001-46	Bolt, 3/8-16 x 2 $\frac{1}{4}$ "			
22	04001-81	Bolt, 3/8-16 x 3 $\frac{1}{2}$ " Full Thread			
23	04003-05	Bolt, Carriage, 3/8-16 x 1 $\frac{1}{2}$ "			
24	43575	Pivot, Idler - Pump			
25	48224	Bearing, Ball, Neutral Ret.			
26	43212	Sleeve, Hydro Linkage			
27	04001-168	Bolt, 3/8-16 x 1 $\frac{1}{4}$ " Grade 8			
28	461682	Frame Weldment, Blower Mounting with Decal			
29	04019-02	Nut, Serrated Flange, 1/4-20			
30	482298	Pulley, 4 $\frac{3}{4}$ " OD - 1" Bore (INCL. 04012-04 Setscrews)			
31	04063-06	Key, 1/4 x 1/4 x 1 $\frac{1}{2}$ "			
32	04019-03	Nut, Serrated Flange, 5/16-18			
33	483034	Bearing Assembly (INCL. Bearing Housing and Bearing)			
34	484696	Decal, Grease Point			
35	04003-04	Bolt, Carriage, 5/16-18 x 1"			
36	461342	Blower Housing w/ Decal, GC			
37	461795	Fan Weldment w/ Bearings (INCL 32,33,35)			
38	421319	Cover, Blower Housing			
39	483393	Decal, Rotating Blower			
40	483391	Decal, Danger			

GC-VRII BLOWER MOUNTING COMPONENTS

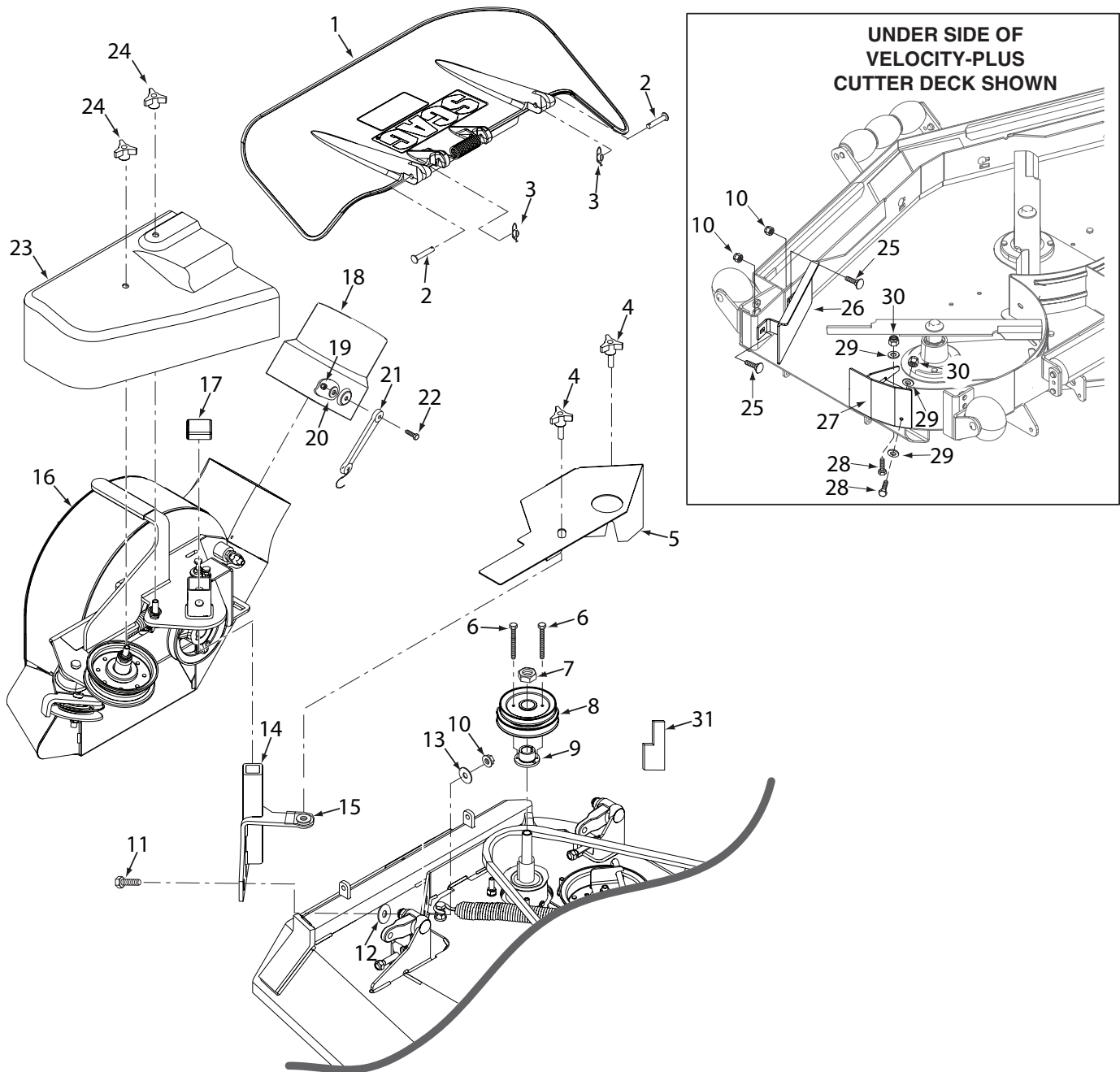

Section 5

GC-VR II BLOWER MOUNTING COMPONENTS

Ref. No.	Part No.	Description
1	461844	Discharge Chute Assy. - 48V
	461845	Discharge Chute Assy. - 52V
	461846	Discharge Chute Assy. - 61V
2	04064-15	Clevis Pin, 5/16 x 1½"
3	04069-03	Pin, Rue Cotter, 5/16 DIA
4	481625-01	Knob With Stud, 3/8-16 x 1¼"
5	427945	Belt Cover, 48GC-VR II
	427819	Belt Cover, 52GC-VR II
	427968	Belt Cover, 61GC-VR II
6	04001-225	Bolt, 1/4-20 x 2½" Full Thread
7	04020-09	Nut, 5/8-11
8	483283	Pulley, 5.13 OD - Double Groove (48)
	486143	Pulley, Double Groove (52)
	486144	Pulley, Double Groove (61)
9	48926	Hub, Tapered, 1.125
10	04021-09	Nut, Lock, Elastic Stop, 3/8-16
11	04001-32	Bolt, 3/8-16 x 1¼"
12	04041-07	Washer, Flat, 3/8, .391 x .938 x .105
13	04030-04	Washer, Lock, 3/8 Spring
14	463133	Mounting Post Assembly, Blower - 48GC-VR II (INCL.15)
	463129	Mounting Post Assembly, Blower - 52GC-VR II (INCL.15)
	463137	Mounting Post Assembly, Blower - 61GC-VR II (INCL.15)
15	04110-03	U-Nut, 3/8-16
16	493216	Blower Assembly, 48/52GC-VR II
	493218	Blower Assembly, 61GC-VR II
17	482300	Cap, Square Vinyl
18	461387	Adapter, With Strap Assembly (INCL.19,20,21,22)
19	04001-59	Bolt, 1/4-20 x 1¼"
20	04040-14	Washer, Flat, 1/4, .312 x .750 x .065
21	48137-04	Rubber Strap 7¾"
22	04021-08	Nut, Lock, Elastic Stop, 1/4-20
23	486348	Belt Cover, 48GC-VR II
	486349	Belt Cover, 52GC-VR II
	486350	Belt Cover, 61GC-VR II
24	04029-04	Wingnut, 3/8 Plastic - Small
25	04003-23	Bolt, Carriage, 3/8-16 x 1"
26	453056	Baffle Weldment, GC-48/52V Blower
	453057	Baffle Weldment, GC-61V Blower
27	424683	Turbo Baffle, Catcher - 48V
	424211	Turbo Baffle, Catcher - 52V
	424212	Turbo Baffle, Catcher - 61V
28	04001-09	Bolt, 5/16-18 x 1"
29	04040-15	Washer, Flat, 5/16, .375 x .875 x .083
30	04021-10	Nut, Lock, Elastic Stop, 5/16-18
31	428125	Pulley Height Tool

GC-VRII HOOD COMPONENTS

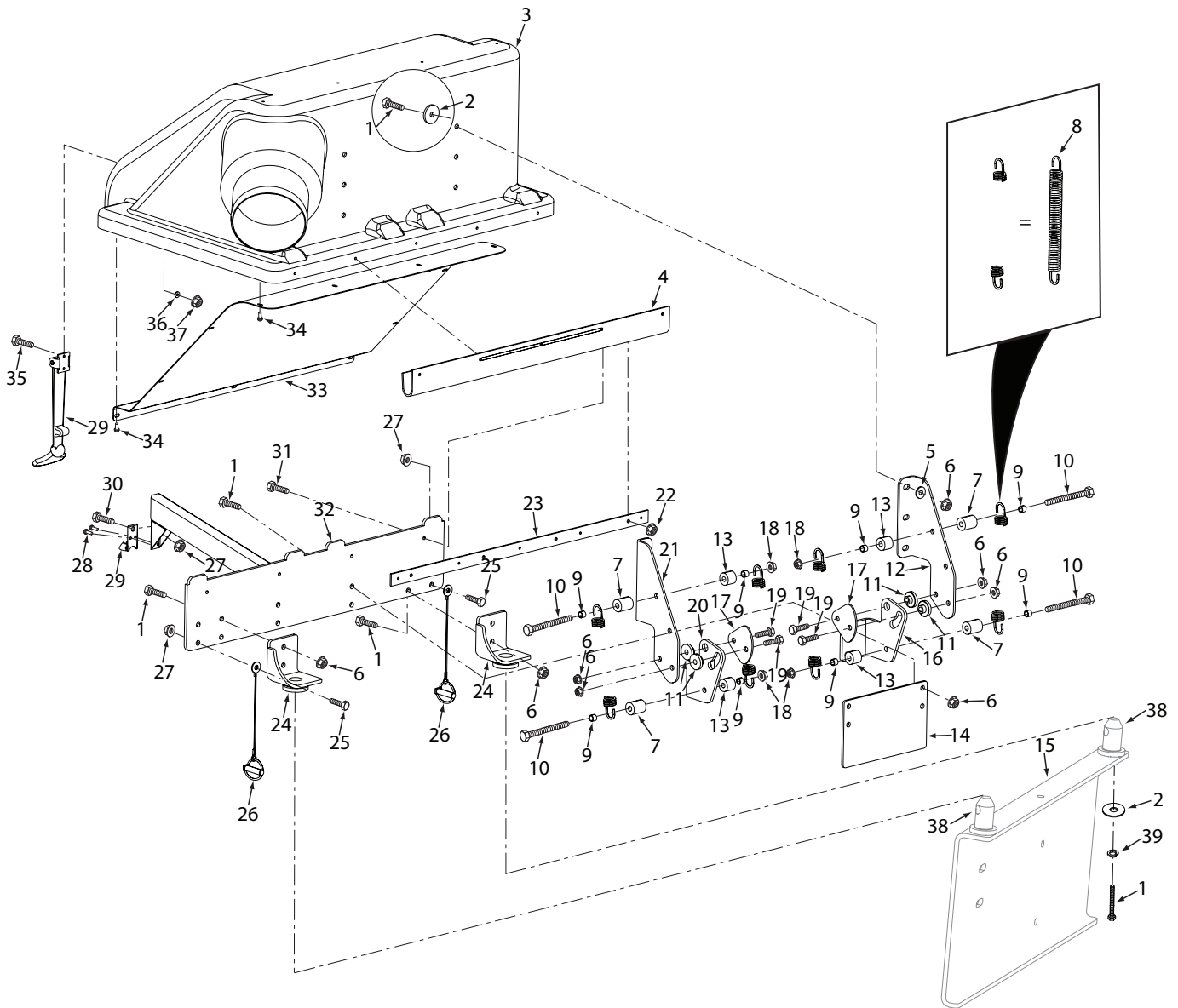

Section 5

GC-VRII HOOD COMPONENTS

Ref. No.	Part No.	Description
1	04001-32	Bolt, 3/8-16 x 1 ¼"
2	04041-11	Washer, Flat 3/8, .406 x 1.5 x .1793
3	462932	Hood Assembly, Catcher With Decal (INCL. 485840,4,23,33,34,36)
4	483589	Hood, Seal
5	04041-07	Washer, Flat, 3/8, .391 x .938 x .1046
6	04021-09	Nut, Lock, Elastic Stop, 3/8-16
7	43886	Spacer, GC Hitch
8	482304	Spring, Hood Hinge
9	43212	Sleeve, Hydro Linkage
10	04001-30	Bolt, 3/8-16 x 4"
11	43546	Bushing, Hopper Pivot
12	425830	Hinge, Upper-LH
13	43277	Spacer, J Pull Rod
14	427840	Plate, Support
15	427790	Bag Support Plate
16	425875	Hinge, Lower-LH
17	425832	Guard, GC Hinge
18	04021-05	Nut, Lock, Center Lock, 3/8-16
19	04001-20	Bolt, 3/8-16 x 1 ½"
20	425876	Hinge, Lower-RH
21	425831	Hinge, Upper-RH
22	04021-02	Nut, Lock, Center Lock, 1/4-20
23	424753	Retainer, Seal
24	453016	Receiver, Weldment
25	04001-09	Bolt, 5/16-18 x 1"
26	483596	Quick Pin Assembly, With Lanyard
27	04021-10	Nut, Lock, Elastic Stop, 5/16-18
28	04090-03	Pop Rivet, 3/16 x .402
29	482409	Draw Latch (Hook and Strap)
30	04001-08	Bolt, 5/16-18 x 3/4"
31	04001-01	Bolt, 1/4-20 x 3/4"
32	452675	Frame Weldment, Bag Support
33	424731	Screen, GC Hood
34	04090-02	Pop Rivet, 3/16 x .652
35	04010-25	Machine Screws, #10-32 x 3/4"
36	04041-19	Washer, Flat, 3/16, .196 x .469 x .0478
37	04021-01	Nut, Lock, Elastic Stop, #10-32
38	43884	Pin, GC Locator
39	04030-04	Washer, Lock, 3/8 Spring

GC-VR7II BAG SUPPORT COMPONENTS

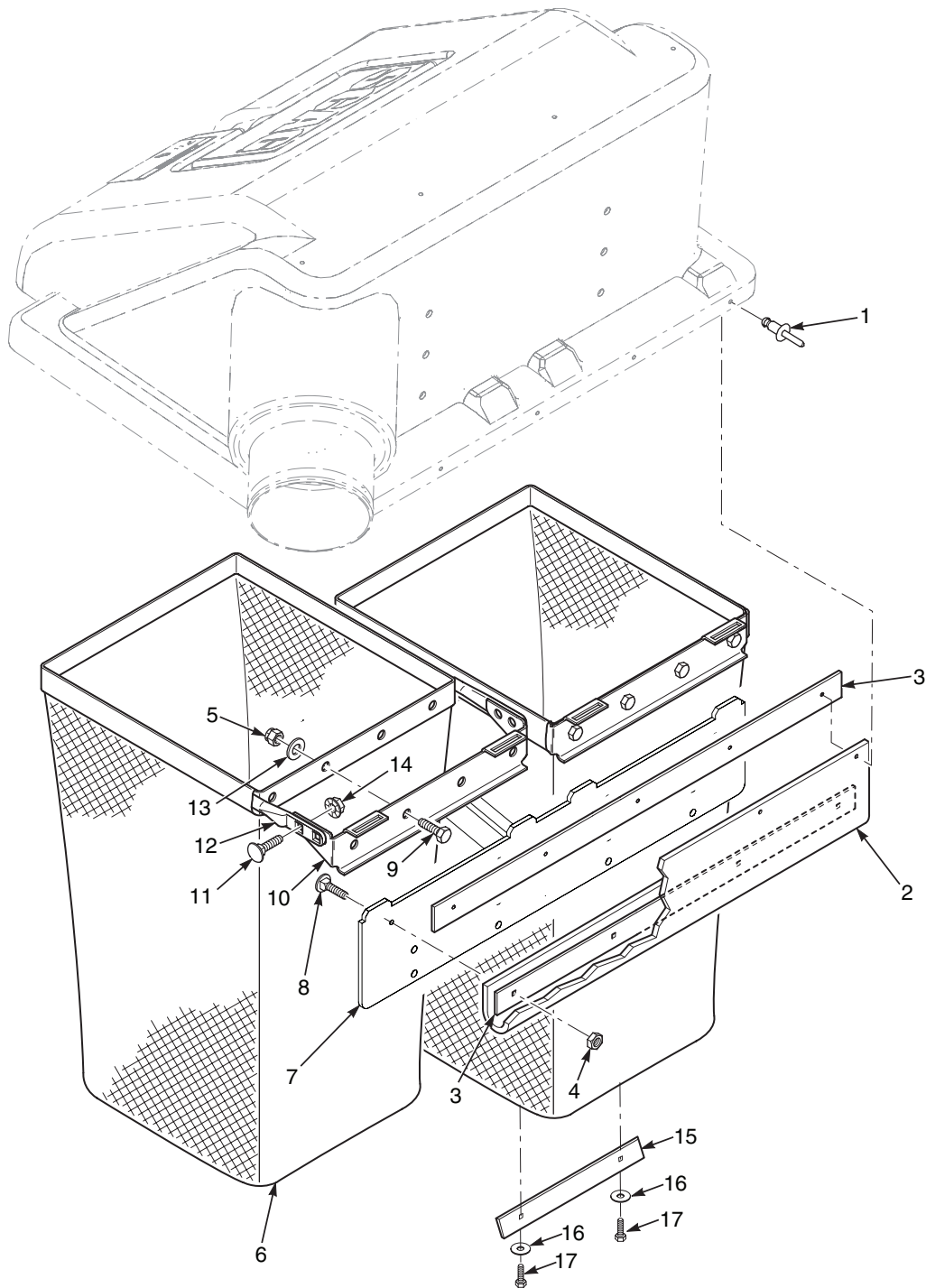

GC-VRII BAG SUPPORT COMPONENTS

Ref. No.	Part No.	Description
1	04090-02	Pop Rivet, 3/16 x .652
2	483589	Seal, GC Hood
3	424753	Retainer, Seal
4	04021-02	Nut, Center Lock 1/4-20
5	04021-10	Nut, Elastic Stop 5/16-18
6	462966	Bag Assembly
7	452675	Frame Weldment, Bag Support
8	04001-01	Bolt, 1/4-20 x 3/4"
9	04001-08	Bolt, 5/16-18 x 3/4"
10	423198	Mount, Bag Frame Tube
11	04003-12	Bolt, Carriage 5/16-18 x 3/4"
12	423197	Tube, Bag Support
13	04040-15	Flatwasher, 5/16-.375 x .875 x .083
14	04019-03	Nut, Serrated Flange 5/16-18
15	427476	Handle
16	04041-11	Washer, Flat, 3/8, .406 x 1.5 x .1793
17	04001-10	Bolt, 5/16-18 x 1 1/4"

GC-VRII SUPPORT FRAME COMPONENTS

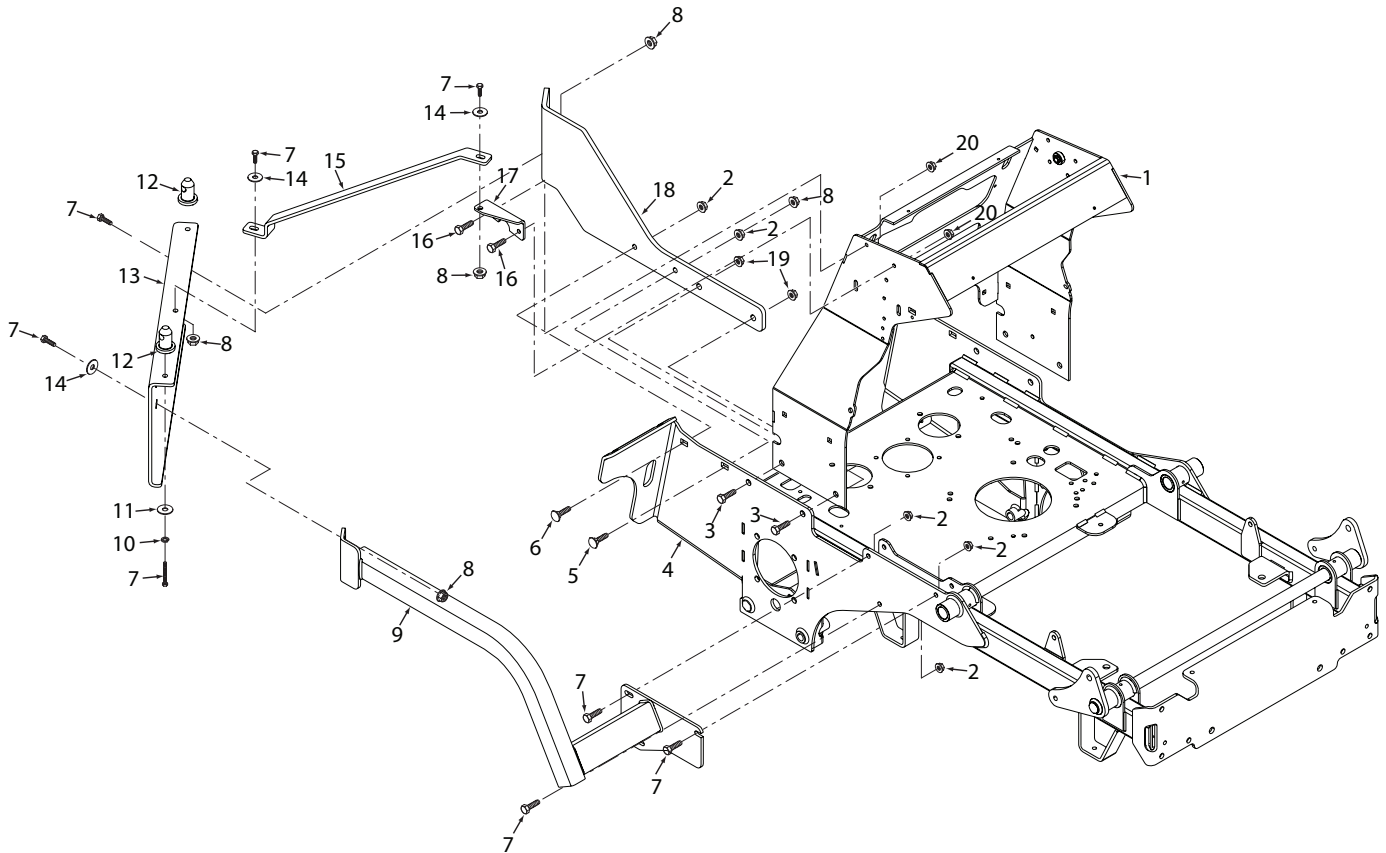

GC-VRII SUPPORT FRAME COMPONENTS

Ref. No.	Part No.	Description
1	452832	Handlebar Weldment, SVRII
2	04019-04	Nut, Serrated Flange, 3/8-16
3	04017-39	Bolt, Serrated Flange, 1/2-13 x 1 3/4"
4	452804	Mainframe Weldment, SVRII
5	04003-03	Bolt, Carriage, 3/8-16 x 2"
6	04003-22	Bolt, Carriage, 3/8-16 x 1 1/4"
7	04001-32	Bolt, 3/8-16 x 1 1/4"
8	04117-02	Nut, Lock, Elastic Stop With Flange, 3/8-16
9	452995	Bracket Weldment, GC Mounting
10	04030-04	Washer, Lock, 3/8 Spring
11	04041-11	Washer, Flat, 3/8, .406 x 1.5 x .1793
12	43884	Pin, GC-SCZ Locator
13	427790	Bag Support, Plate
14	04041-07	Washer, Flat, 3/8, .391 x .938 x .1046
15	427791	Upper Support Bracket
16	04001-09	Bolt, 5/16-18 x 1"
17	427792	Mounting Bracket, Upper
18	427806	GC Mounting Bracket, LH
19	04019-06	Nut, Serrated Flange, 1/2-13
20	04019-03	Nut, Serrated Flange, 5/16-18

GC-VRII FRONT WEIGHT COMPONENTS

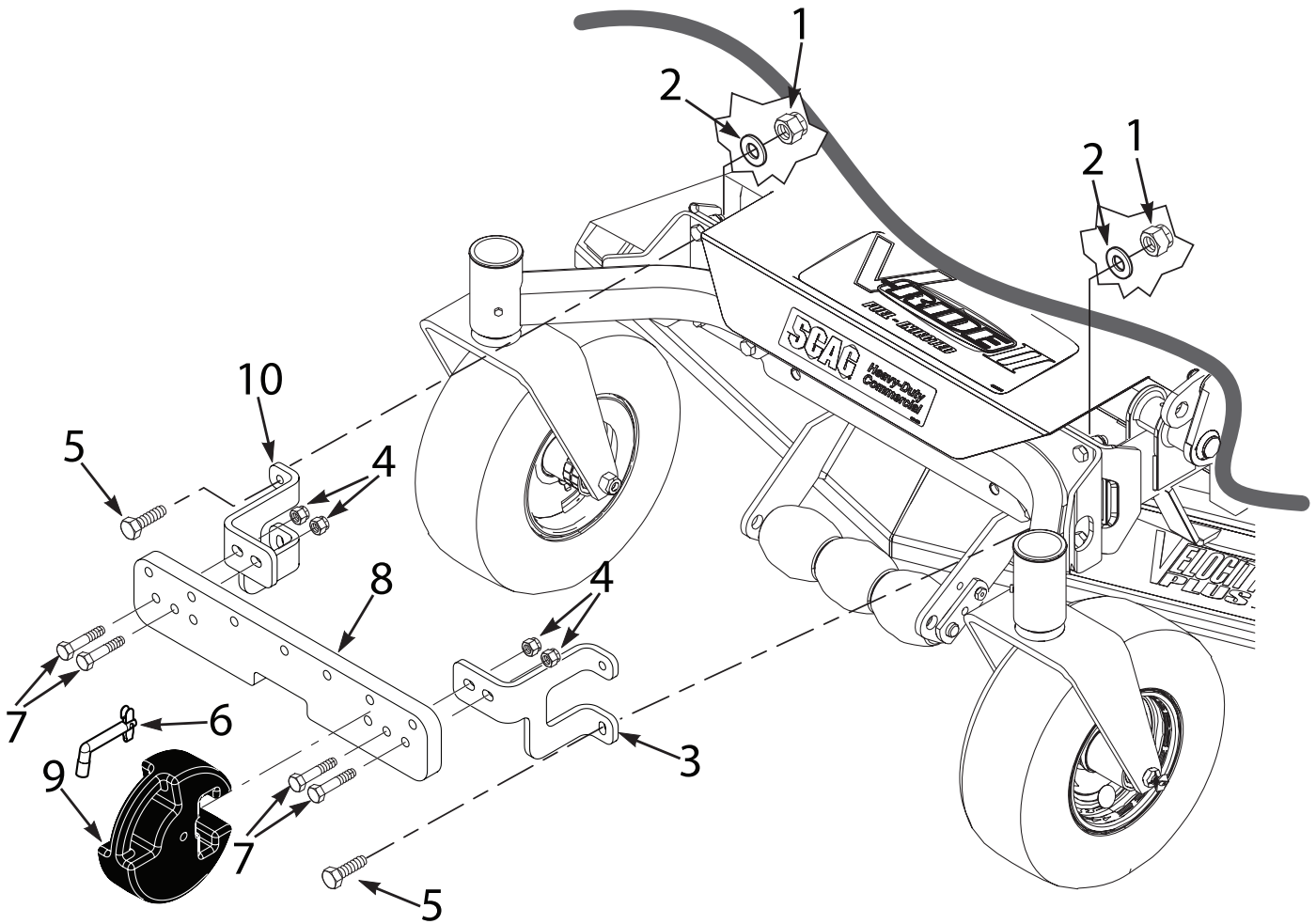

GC-VRII FRONT WEIGHT COMPONENTS

Ref. No.	Part No.	Description
1	04021-11	Nut, Lock, elastic Stop, 7/16-14
2	04030-05	Washer, Lock, 7/16 Spring
3	427851	Mounting Bracket, Weight Bar - LH
4	04117-04	Nut, Lock, elastic Stop With Flange, 1/2-13
5	04001-117	Bolt, 7/16-14 x 1¾"
6	485172	Pin, Weight Retention
7	04001-153	Bolt, 1/2-13 x 2¼"
8	426093	Weight Bar
9	484758	GC Weight
10	427852	Mounting Bracket, Weight Bar - RH

***Weights Required**

<u>Model</u>	<u>Qty.</u>
SVRII 48/52/61	1

GC-VRII DECALS



483402

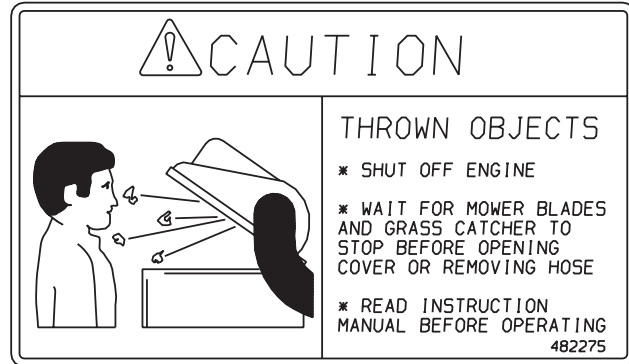

482275



482733

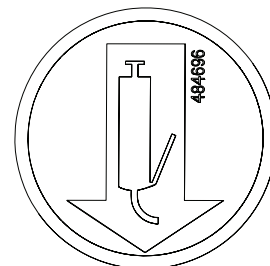

484696

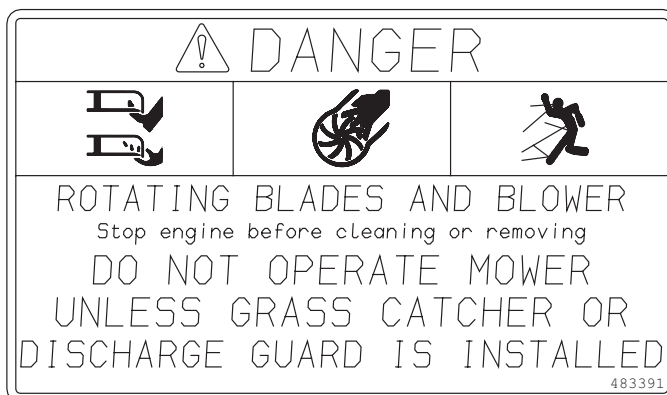

483391

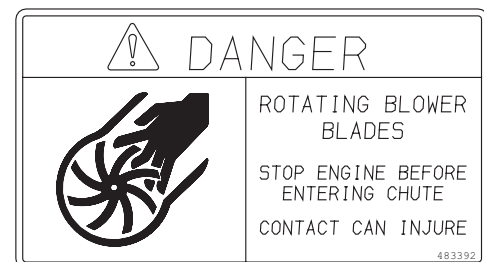

483039

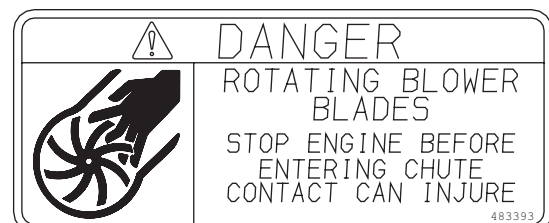

483393

LIMITED WARRANTY- COMMERCIAL ACCESSORY

Any part of the Scag commercial accessory manufactured by Scag and found, in the reasonable judgment of Scag, to be defective in material or workmanship, will be repaired or replaced by an Authorized Scag Service Dealer without charge for parts and labor.

The Scag accessory, including any defective part, must be returned to an Authorized Scag Service Dealer within the warranty period. The expense of delivering the accessory to the dealer for warranty work and the expense of returning it back to the owner after repair or replacement will be paid for by the owner. Scag's responsibility in respect to claims is limited to making the required repairs or replacements, and no claim of breach of warranty shall be cause for cancellation or rescission of the contract of sale of any Scag machine. Proof of purchase will be required by the dealer to substantiate any warranty claim. All warranty work must be performed by an Authorized Scag Service Dealer.

This warranty is limited to 90 days from the date of original retail purchase for any Scag accessory that is used for commercial purposes, or any other income-producing purpose including rental use.

The warranty for the grass catcher blower assemblies (excluding the belt) is limited to 1-year from the date of original retail purchase. 90 Days for rental use.

This warranty does not cover any accessory that has been subject to misuse, neglect, negligence, or accident, or that has been operated in any way contrary to the operating instructions as specified in the Operator's Manual. The warranty does not apply to any damage to the accessory that is the result of improper maintenance, or to any accessory or parts that have not been assembled or installed as specified in the Operator's Manual.

The warranty does not cover any accessory that has been altered or modified. In addition, the warranty does not extend to repairs made necessary by normal wear, or by the use of parts or accessories which, in the reasonable judgment of Scag, are either incompatible with the Scag mower or adversely affect its operation, performance or durability. This warranty does not cover engines and electric starters, which are warranted separately by their manufacturer.

Scag Power Equipment reserves the right to change or improve the design of any accessory without assuming any obligation to modify any accessory previously manufactured.

All other implied warranties are limited in duration to the 90 day warranty period. Accordingly, any such implied warranties including merchantability, fitness for a particular purpose, or otherwise, are disclaimed in their entirety after the expiration of the appropriate ninety day warranty period. Scag's obligation under this warranty is strictly and exclusively limited to the repair or replacement of defective parts and Scag does not assume or authorize anyone to assume for them any other obligation. Some states do not allow limitations on how long an implied warranty lasts, so the above limitation may not apply to you.

Scag assumes no responsibility for incidental, consequential or other damages including, but not limited to, expense for gasoline, oil, expense of delivering the machine to an Authorized Scag Service Dealer and expense of returning it back to the owner, mechanic's travel time, telephone or telegram charges, rental of a like product during the time warranty repairs are being performed, travel, loss or damage to personal property, loss of revenue, loss of use of the mower, loss of time, or inconvenience. Some states do not allow the exclusion or limitation of incidental or consequential damages, so the above limitation or exclusion may not apply to you.

This warranty gives you specific legal rights, and you may also have other rights which vary from state to state.