

SCAG[®]

POWER EQUIPMENT

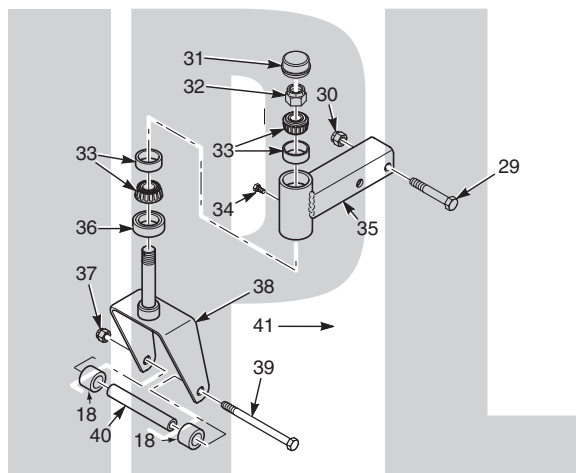

ILLUSTRATED PARTS MANUAL



Model SCZII Cheetah II

THIS MANUAL CONTAINS THE ILLUSTRATED PARTS LIST FOR MODELS:

SCZII61V-38FX-EFI
SCZII61V-37BV-EFI
SCZII61RD-38FX-EFI
SCZII72V-38FX-EFI
SCZII72V-37BV-EFI

with a serial number of R900001 to R9099999
with a serial number of P9500001 to P9599999
with a serial number of R9100001 to R9199999
with a serial number of R9200001 to R9299999
with a serial number of P9800001 to P9899999

Table of Contents

SCAG APPROVED ATTACHMENTS AND ACCESSORIES.....	2
61V & 72V CUTTER DECKS	4
61RD CUTTER DECK	6
CUTTER DECK CONTROLS	8
SHEET METAL COMPONENTS	10
SCZII ROLL-OVER PROTECTION SYSTEM.....	12
SCZII SEAT ASSEMBLY	14
SCZII SUSPENSION SYSTEM	16
SCZII STEERING COMPONENTS.....	18
SCZII DRIVE SYSTEM COMPONENTS	20
SCZII SPEED CONTROL COMPONENTS	22
SCZII BRAKE COMPONENTS	24
SCZII HYDRAULIC SYSTEM	26
SCZII FUEL SYSTEM.....	28
SCZII ENGINE & ATTACHING PARTS	30
ZT-5400 TRANSAXLE ASSEMBLY.....	32
SCZII EFI ELECTRICAL SYSTEM.....	34
REPLACEMENT DECALS AND INFORMATION PLATES	36
SCZII BV - EFI ELECTRICAL SCHEMATIC	38
BRIGGS & STRATTON - EFI ADAPTER HARNESS ELECTRICAL SCHEMATIC.....	39
SCZII FX-EFI ELECTRICAL SCHEMATIC.....	40

ILLUSTRATED PARTS LIST

SCAG APPROVED ATTACHMENTS AND ACCESSORIES

Attachments and accessories manufactured by companies other than Scag Power Equipment are not approved for use on this machine.

Scag approved attachments and accessories:

- GC-3B (p/n 901S) - Requires a 900X (61 STT/SCZ Install Kit)
- GC-CS (p/n 901T) - Requires a 900X (61 STT/SCZ Install Kit)
- Mulch Plate (p/n 9288, 920F)
- Hurricane Mulch (p/n 9285, 920E)
- SCZ Hitch (p/n 9242)
- SCZ/STT-OCDC-61V (p/n 923D)
- SCZ Striper (p/n 923G) - Requires a 921W Install Kit
- Air Filter Indicator (922U)
- Blade Buddy (p/n 9212)

Scag Premium Lubricants:

- Chassis Grease (p/n 486257)
- Spindle Grease (p/n 486258)
- 20W50 Oil - Gallon (p/n 486254)
- 20W50 Oil - Quart (p/n 486255)

NOTES

61V & 72V CUTTER DECKS

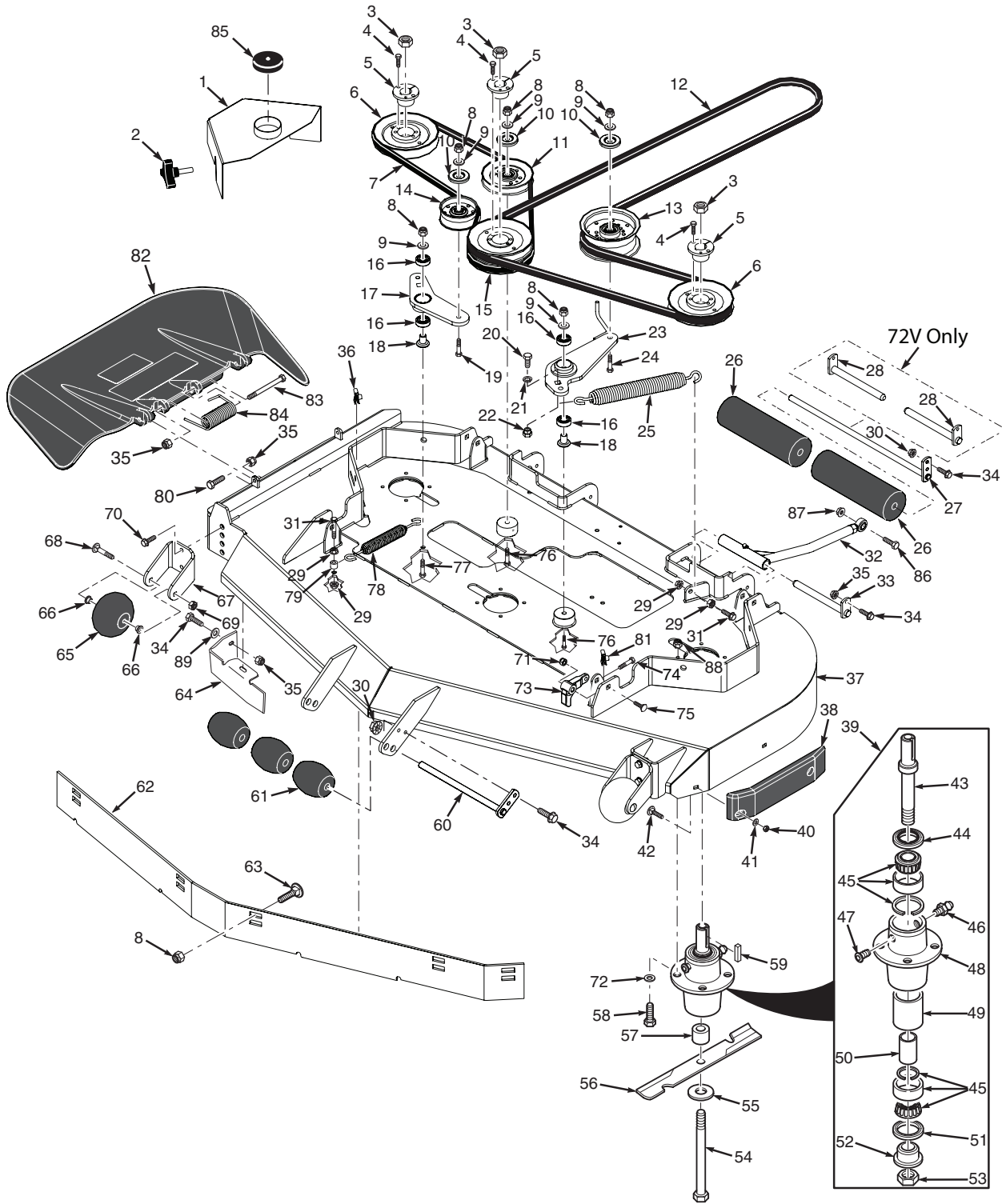

61V & 72V CUTTER DECKS

Ref. No.	Part No.	Description	61	72
1	463194	Belt Cover, LH (INCL 85)	x	
	463195	Belt Cover, RH (INCL 85)	x	
	462409	Belt Cover, 72V		x
2	481625-01	Knob w/Stud	x	x
3	04020-09	Nut, 5/8-11 UNC	x	x
4	04001-172	Bolt, Hex Head 1/4-20 x 1"	x	x
5	48926	Tapered Hub, 1.125" Bore	x	x
6	483286	Pulley, 6.32" Dia.	x	
	484050	Pulley, 7.50" Dia.		x
7	483157	Belt	x	
	484159	Belt		x
8	04021-09	Nut, Elastic Stop 3/8-16	x	x
9	04043-04	Flatwasher, 3/8-.391 x .938		
		x .105	x	x
10	424367	Dust Shield	x	x
11	48181	Pulley, Idler	x	x
12	483741	Belt, Deck Drive	x	
	484088	Belt, Deck Drive		x
13	483210	Pulley, 5" Idler	x	x
14	486045	Pulley, 3-1/2" Idler	x	x
15	483287	Pulley, 6.32" Dia. Double Groove		x
		484051	Pulley, 7.50" Dia. Double Groove	
	48224	Bearing	x	x
17	461946	Idler Arm Assy. (incl. #16)	x	x
18	43689	Pivot, Idler	x	x
19	04001-31	Bolt, Hex Head 3/8-16 x 2-1/2"	x	x
		Bolt, Hex Head 7/16-14 x 1"	x	x
21	04030-05	Lockwasher, 7/16" Spring	x	x
22	43686	Boss, Spring Anchor	x	x
23	462269	Idler Arm Assy. (incl. #16)	x	x
24	04001-54	Bolt, Hex Head 3/8-16 x 3"	x	x
25	483246	Spring, LH Cutter Deck	x	x
26	48038	Guide Roller	x	x
27	451118	Shaft Weldment	x	
28	45944	Shaft Weldment		x
29	04019-04	Nut, Serrated Flange 3/8-16	x	x
30	04117-01	Nut, Lock Elastic Stop, 5/16-18	x	x
		Bolt, Hex Head 3/8-16 x 1-1/2" Grade 8	x	x
32	462225	Pusharm Assy., LH	x	x
	462226	Pusharm Assy., RH	x	x
33	451240	Rod Weldment, Pusharm	x	x
34	04001-09	Bolt, Hex Head 5/16-18 x 1"	x	x
35	04021-10	Nut, Elastic Stop 5/16-18	x	x
36	04110-04	U-Nut, 3/8-16	x	x
37	463243	Cutter Deck w/Decals	x	
	463244	Cutter Deck w/Decals		x
38	483176	Wear Pad	x	
	483174	Wear Pad		x
39	461663	Spindle Assembly	x	x
40	04021-04	Nut, Center Lock 5/16-18	x	x
41	04040-04	Flatwasher, 5/16-.344 x .688		
		x .065	x	x
42	04003-12	Bolt, Carriage 5/16-18 x 3/4"	x	x
43	43589	Shaft, Spindle	x	x
44	481024	Seal, Top	x	x
45	481022	Bearing Assembly	x	x

Ref. No.	Part No.	Description	61	72
46	48114-04	Grease Fitting	x	x
47	48677	Relief Fitting, Spindle	x	x
48	43644	Spindle Housing	x	x
49	43312	Spacer, Outside	x	x
50	43296	Spacer, Inside	x	x
51	481025	Seal, Bottom	x	x
52	43297	Spindle Bushing	x	x
53	481035	Nut, Special 1-1/16 - 18	x	x
54	04001-41	Bolt, Hex Head 5/8-11 x 9-1/2"		x
		55	04043-06	Flatwasher, 5/8-.688 x 1.75 x .134 HD
56	482881	Cutter Blade, 21"	x	
	482882	Cutter Blade, 24-1/2"		x
57	43590	Spacer, Spindle Bottom	x	x
58	04001-176	Bolt, Hex Head 5/16-18 x 1-3/4" Grade 8		x
		59	04063-08	Key, 1/4 x 1/4 x 2"
60	45944	Shaft Weldment	x	x
61	482295	Wheel, Anti-Scalp	x	x
62	424841	Baffle, Flange - 61V	x	
	424917	Baffle, Flange - 72V		x
63	04003-23	Bolt, Carriage 3/8-16 x 1"	x	x
64	424209	Baffle, Turbo - 61V	x	
		*425625	Discharge Baffle 61V	x
	424856	Baffle, Turbo - 72V		x
	*423958	Discharge Baffle 72V		x
65	481632	Wheel, Anti-Scalp	x	x
66	48100-15	Bushing, .376 ID Oilite	x	x
67	422478	Bracket, Anti-Scalp Wheel	x	x
68	04003-26	Bolt, Carriage 3/8-16 x 4"	x	x
69	04021-05	Nut, Center Lock 3/8-16	x	x
70	04017-27	Bolt, Hex Head 3/8-16 x 1"		x
		Serrated Flange	x	x
	04021-11	Nut, Elastic Stop 7/16-14	x	x
72	04030-03	Lock Washer, 5/16	x	x
73	485528	Lever, Deck Level	x	x
74	04107-05	Bolt, 3/8-16 x 2-1/2" w/Patch	x	x
75	04003-42	Bolt, Carriage 7/16-14 x 2-1/4"		x
		76	04001-54	Bolt, Hex Head 3/8-16 x 3"
77	04001-46	Bolt, Hex Head 3/8-16 x 2-1/4"		x
78	483703	Deck Spring	x	x
79	43063	Spacer	x	x
80	04001-12	Bolt, Hex Head 5/16-18 x 1-3/4"		x
		81	04110-03	U-Nut, 3/8-16
82	461846	Discharge Chute Assy. 61V	x	
	*462477	CA Discharge Chute Assy.	x	
	462132	Discharge Chute Assy. 72V		x
	*462478	CA Discharge Chute Assy.		x
83	04001-154	Bolt, Hex Head 5/16-18 x 4-3/4"	x	x
		84	483378	Spring, Discharge Chute
85	484368	Cap, Spindle	x	x
86	04001-128	Bolt, Hex Head 5/8-11 x 3/2"	x	x
87	04021-23	Nut, Centerlock, 5/8-11	x	x
88	04021-22	Nut, Lock Elastic Stop, 5/16-18		x
		89	04040-15	Flat Washer, 5/16 - .375 x .875 x .083

* = California Models Only (not shown)

61RD CUTTER DECK

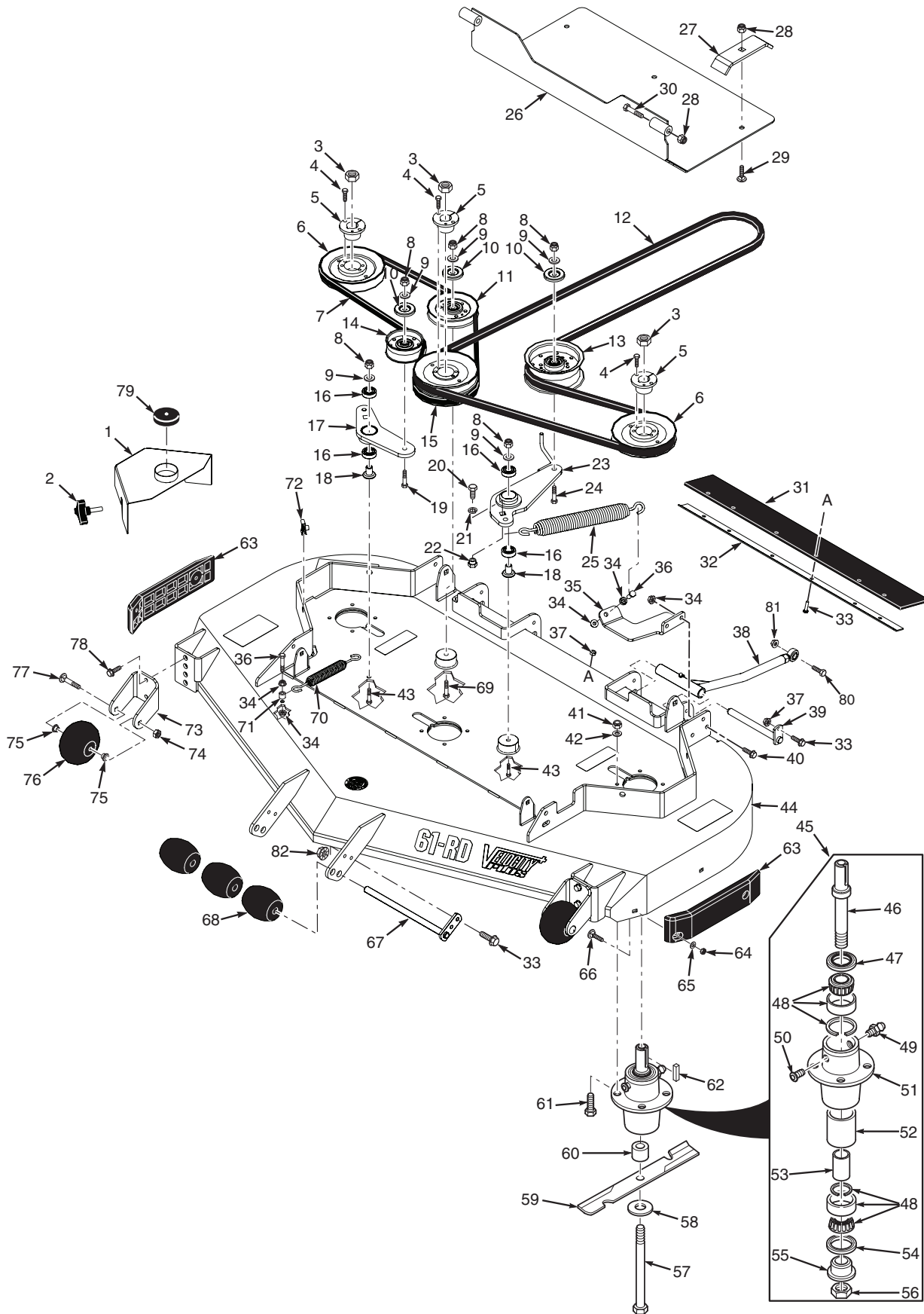

61RD CUTTER DECK

Ref. No.	Part No.	Description
1	463194	Belt Cover, LH 61V
	463195	Belt Cover, RH 61V
2	481625-01	Knob w/Stud
3	04020-09	Nut, 5/8-11 UNC
4	04001-172	Bolt, Hex Head 1/4-20 x 1"
5	48926	Tapered Hub, 1.125" Bore
6	483286	Pulley, 6.32" Dia.
7	483157	Belt
8	04021-09	Nut, Elastic Stop 3/8-16
9	04043-04	Flatwasher, 3/8-.391 x .938 x .105
10	424367	Dust Shield
11	48181	Pulley, Idler
12	483741	Belt, Deck Drive
13	483210	Pulley, 5" Idler
14	486045	Pulley, 3-1/2" Idler
15	483287	Pulley, 6.32" Dia. Double Groove
16	48224	Bearing
17	461946	Idler Arm Assy. (incl. #16)
18	43689	Pivot, Idler
19	04001-31	Bolt, Hex Head 3/8-16 x 2-1/2"
20	04001-27	Bolt, Hex Head 7/16-14 x 1"
21	04030-05	Lockwasher, 7/16" Spring
22	43686	Boss, Spring Anchor
23	462269	Idler Arm Assy. (incl. #16)
24	04001-54	Bolt, Hex Head 3/8-16 x 3"
25	483246	Spring, LH Cutter Deck
26	452341	Weldment, Debris Shield
27	425897	Mounting Bracket, Shield
28	04021-10	Nut, Elastic Stop 5/16-18
29	04003-38	Bolt, Carriage 5/16-18 x 1-1/2"
30	04001-13	Bolt, Hex Head 5/16-18 x 2-3/4"
31	484557	Pad, Rubber
32	425899	Retaining Plate, Pad
33	04001-09	Bolt, Hex Head 5/16-18 x 1"
34	04019-04	Nut, Serrated Flange 3/8-16
35	425335	Spring Mount, SMCZ
36	04001-136	Bolt, Hex Head 3/8-16 x 1-1/2" Grade 8
37	04021-10	Nut, Elastic Stop 5/16-18
38	462225	Pusharm Assembly, LH
	462226	Pusharm Assembly, RH
39	451240	Rod Weldment, Pusharm
40	04001-19	Bolt, Hex Head 3/8-16 x 1"
41	04021-22	Nut, Elastic Stop 5/16-18 Grade 8
42	04030-03	Lockwasher, 5/16"
43	04001-54	Bolt, Hex Head 3/8-16 x 3"
44	463245	Cutter Deck Assembly w/Decals SCZII-61RD

Ref. No.	Part No.	Description
45	461663	Spindle Assembly
46	43589	Shaft, Spindle
47	481024	Seal, Top
48	481022	Bearing Assembly
49	48114-04	Grease Fitting
50	48677	Relief Fitting, Spindle
51	43644	Spindle Housing
52	43312	Spacer, Outside
53	43296	Spacer, Inside
54	481025	Seal, Bottom
55	43297	Spindle Bushing
56	481035	Nut, Special 1-1/16 - 18
57	04001-41	Bolt, Hex Head 5/8-11 x 9-1/2"
58	04043-06	Flatwasher, 5/8-.688 x 1.75 x .134 HD
59	482881	Cutter Blade, 21"
60	43590	Spacer, Spindle Bottom
61	04001-176	Bolt, Hex Head 5/16-18 x 1-3/4" Grade 8
62	04063-08	Key, 1/4 x 1/4 x 2"
63	483176	Wear Pad
64	04021-04	Nut, Center Lock 5/16-18
65	04040-04	Flatwasher, 5/16-.344 x .688 x .065
66	04003-12	Bolt, Carriage 5/16-18 x 3/4"
67	45944	Shaft Weldment
68	482295	Wheel, Anti-Scalp
69	04001-46	Bolt, Hex Head 3/8-16 x 2-1/4"
70	483703	Deck Spring
71	43063	Spacer
72	04110-04	U-Nut, 3/8-16
73	422478	Bracket, Anti-Scalp Wheel
74	04021-05	Nut, Center Lock 3/8-16
75	48100-15	Bushing, .376 I.D. Oilite
76	481632	Wheel, Anti-Scalp
77	04003-26	Bolt, Carriage 3/8-16 x 4"
78	04017-27	Bolt, Hex Head Serrated Flange 3/8-16 x 1"
79	484368	Cap, Spindle
80	04001-128	Bolt, Hex Head, 5/8-11 x 3 1/2"
81	04021-23	Nut, Centerlock, 5/8-11
82	04117-01	Nut, Lock Elastic Stop, 5/16-18

CUTTER DECK CONTROLS

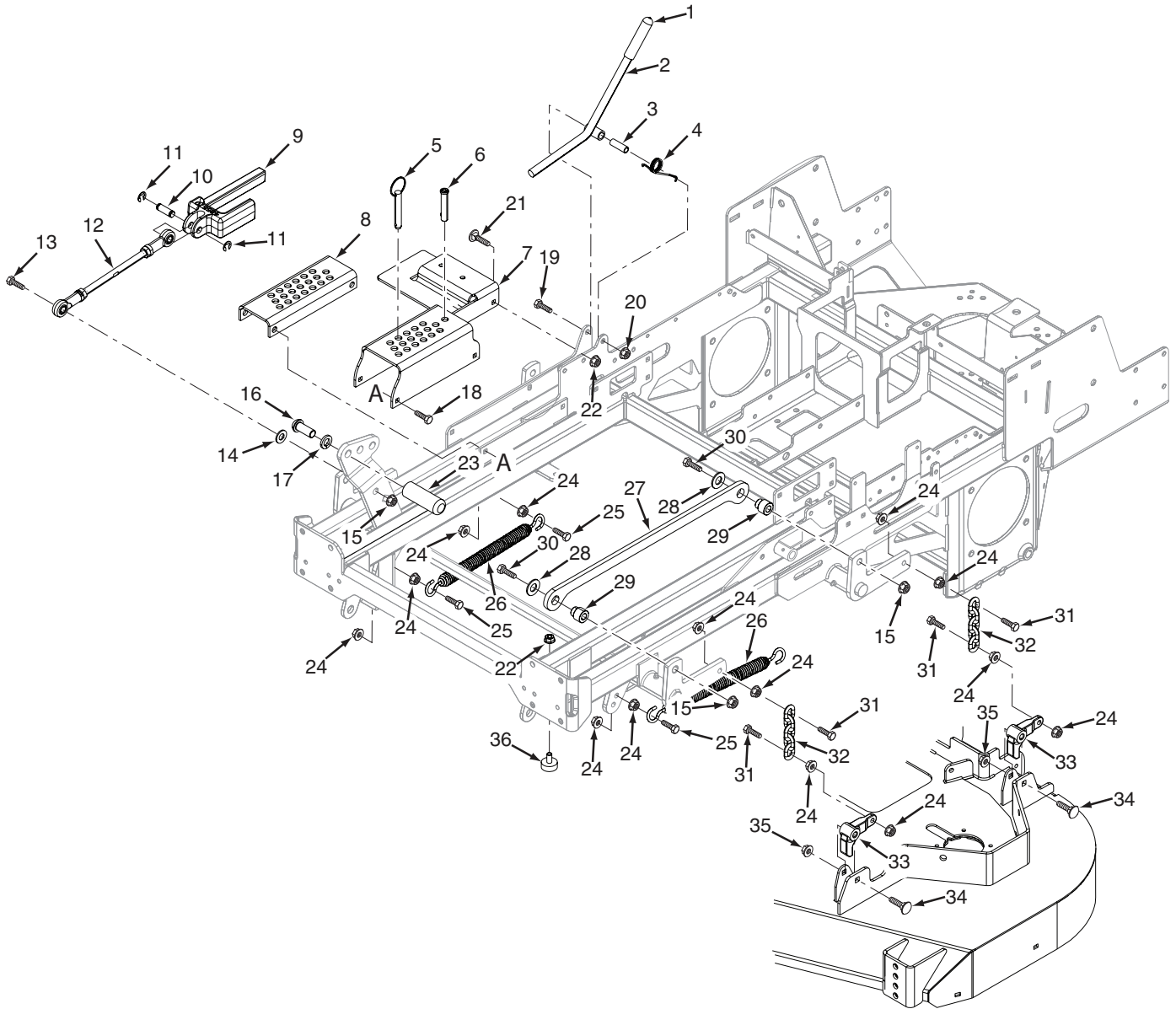

CUTTER DECK CONTROLS

Ref. No.	Part No.	Description
1	481477	Grip, Deck Latch
2	462253	Deck Latch Assembly w/Grip
3	43668	Spacer, Deck Latch
4	484191	Spring, Torsion Return Lever
5	483345	Ring Pin Assembly w/Lanyard
6	04059-01	Pin, Locking
7	463235	Adjustment Bracket, Upper Cut Height
8	452408	Adjustment Bracket, Lower Cut Height
9	462883	Slide, Height Adjustment Assembly (INCL. 10,11,12)
10	43487	Pin, Deck Lift
11	04050-18	Retaining Ring, 1/2" External "E"
12	484141	Linkage, Deck Lift
	481765	Rod End, 1/2-20 RH Female
	481766	Rod End, 1/2-20 LH Female
	04020-27	Nut, 1/2-20 UNF Jam
	04020-28	Nut, 1/2-20 UNF LH Jam
13	04001-72	Bolt, Hex Head 1/2-13 x 2"
14	04040-07	Flatwasher, 1/2-.531 X 1.062 X .095
15	04021-07	Nut, Lock Elastic Stop, 1/2-13
16	04108-04	Bolt, 5/8-11 x 1-1/2"
17	04030-07	Lock Washer, 5/8 Spring
18	04006-02	Bolt, 5/16-18 x 1-1/4"
19	04001-22	Bolt, 3/8-16 x 2-3/4"
20	04021-09	Nut, Lock Elastic Stop, 3/8-16
21	04003-12	Bolt, Carriage, 5/16-18 x 3/4"
22	04019-03	Nut, Serrated Flange, 5/16-18
23	424504	Pedal, Foot
24	04019-04	Nut, Serrated Flange, 3/8-16
25	04001-136	Bolt, 3/8-16 x 1-1/2"
26	481598	Spring, Deck Lift
27	428214	Link, Deck Lift
28	04040-13	Flat Washer, 1/2- .562 x 1.375 x .109
29	431018	Pivot, Deck Link
30	04001-153	Bolt, 1/2-13 x 2-1/4"
31	04001-20	Bolt, 3/8-16 x 1-1/2"
32	482628	Chain Assembly (INCL. 24,31)
33	485528	Lever, Deck Level
34	04003-42	Bolt, Carriage 7/16-14 x 2-1/4"
35	04021-11	Nut, Elastic Stop, 7/16-14
36	481284	Bumper, Rubber

SHEET METAL COMPONENTS

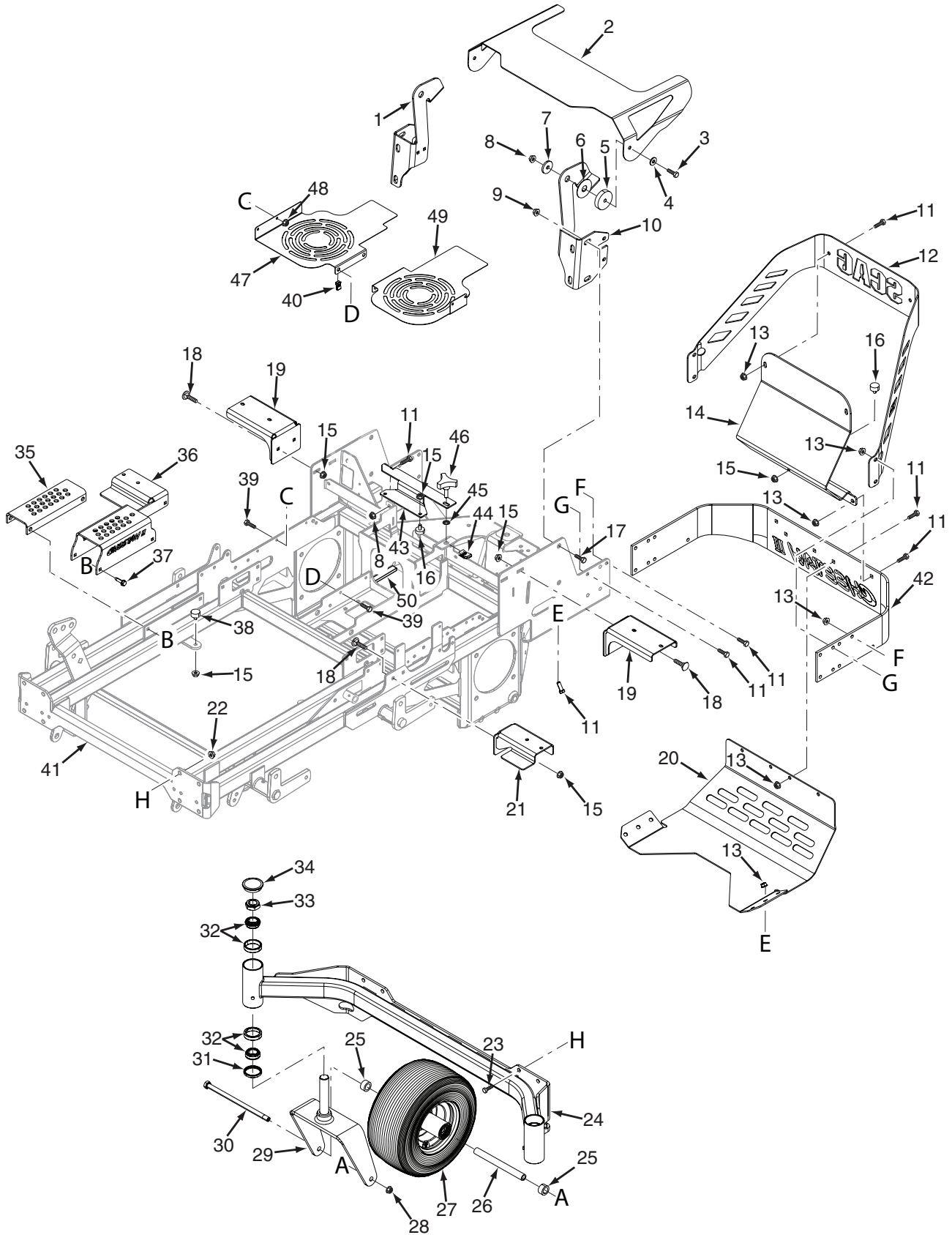

SHEET METAL COMPONENTS

Ref. No.	Part No.	Description
1	427178	Rops Mounting RH
2	428312	Hood, SCZII
3	04001-21	Bolt, 3/8-16 x 1-3/4"
4	04041-07	Flat Washer, 3/8 - .391 x .938 x .105
5	43740	Spacer, Hood
6	483471	Disc, Anti Friction
7	04041-11	Flat Washer, 3/8 - .406 x 1.5 x 7 Ga
8	04021-09	Nut, Lock Elastic Stop, 3/8-16
9	04117-04	Nut, Lock Flange Elastic Stop, 1/2-13
10	427177	Rops Mounting LH
11	04001-19	Bolt, 3/8-16 x 1"
12	428202	Engine Cover, Sides
13	04019-04	Nut, Serrated Flange, 3/8-16
14	428333	Engine Cover, Rear
15	04019-03	Nut, Serrated Flange, 5/16-18
16	481284	Bumper, Rubber
17	04001-70	Bolt, 1/2-13 x 1-1/4"
18	04003-12	Bolt, Carriage, 5/16-18 x 3/4"
19	428261	Mounting Bracket, Fuel Tank Rear
20	428292	Skid Plate, Rear
21	428233	Mounting Bracket, Fuel Tank Front
22	04117-05	Nut, Lock Flange Elastic Stop, 7/16-14
23	04001-28	Bolt, 7/16-14 x 1-1/4"
24	452193	Caster Support 61V
	452194	Caster Support 72V
25	43584	Spacer, Caster Wheel
26	43583	Sleeve, Caster Wheel
27	9278	Caster Wheel Assembly
	482621	Bearing
	482622	Seal
28	04021-07	Nut, Lock Elastic Stop, 1/2-13
29	453110	Yoke Weldment
30	04001-167	Bolt, 1/2-13 x 9-1/2"
31	481025	Seal, 2" OD x 1.625 Bore
32	48668	Bearing 1" DIA
33	04021-20	Nut, Lock Jam Elastic Stop, 1"-14
34	484195	Grease Cap
35	452408	Bracket, Lower Cutting Height
36	428228	Bracket, Upper Cutting Height
37	04006-02	Bolt, 5/16-18 x 1-1/4"
38	484201	Bumper, Rubber
39	04017-05	Bolt, Serrated Flange, 1/4-20 x 3/4"
40	04110-01	U-Nut, 1/4-20
41	463242	Frame w/ Decals
42	428206	Bumper, Rear
43	428236	Cover, Battery Box
44	04110-03	U-Nut, 3/8-16
45	04024-02	Nut, Push-On - 3/8 Thd
46	481625-01	Knob w/ Stud, 3/8-16 x 1-1/4"
47	425300	Fan Cover, RH
48	04019-02	Nut, Serrated Flange, 1/4-20
49	425299	Fan Cover, LH
50	48661	Pad, Rubber

SCZII ROLL-OVER PROTECTION SYSTEM

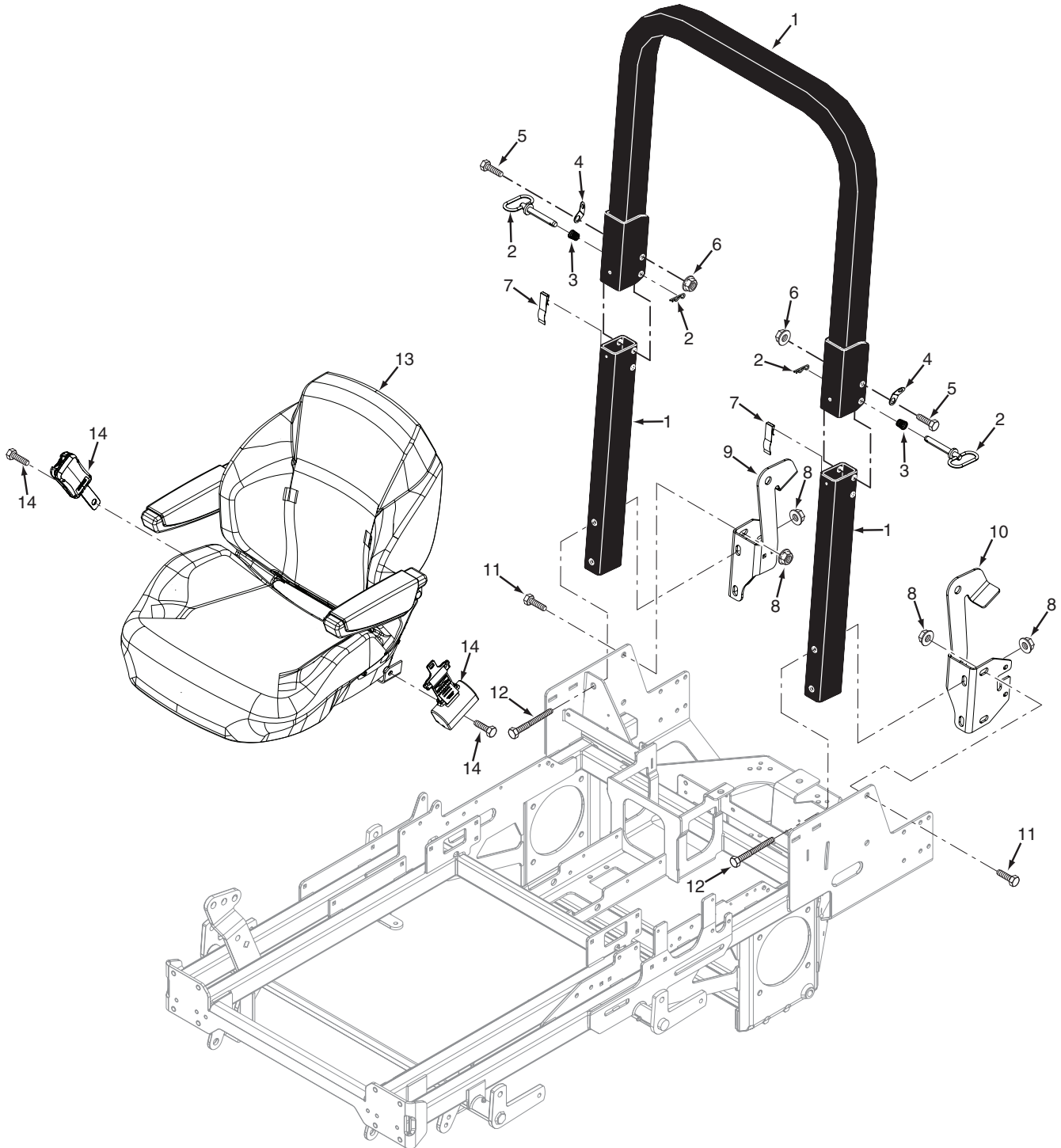

SCZII ROLL-OVER PROTECTION SYSTEM

Ref. No.	Part No.	Description
1	462246	ROPS, Foldable SCZII
2	484168	Pin Assembly (incl. #3, #4)
3	484170	Spring, ROPS
4	484169	Clip, ROPS
5	04001-90	Bolt, Hex Head 1/2-13 x 3-1/4"
6	04021-07	Nut, Elastic Stop 1/2-13
7	484167	Spring Clip, ROPS
8	04117-04	Nut, Lock Flange Elastic Stop, 1/2-13
9	427178	Rops Mount RH
10	427177	Rops Mount LH
11	04001-70	Bolt, Hex Head 1/2-13 x 1-1/4"
12	04001-194	Bolt, Hex Head 1/2-13 x 4-1/4"
13	486507	Seat Assembly (INCL 14)
14	486620	Seat Belt Kit, Retractable - SCZII

SCZII SEAT ASSEMBLY

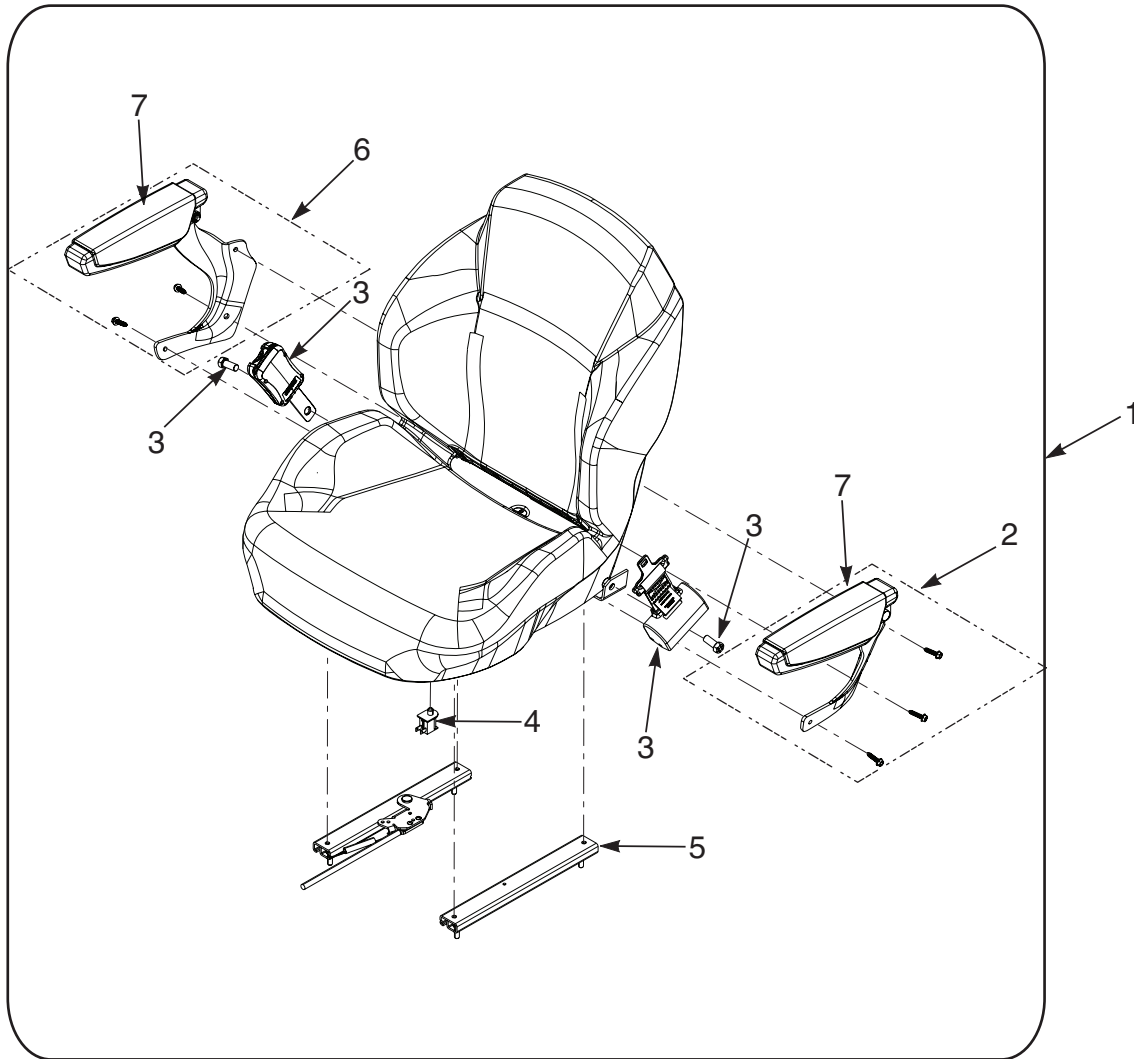

Ref. No.	Part No.	Description
1	486507	Seat Assembly - SCZII
2	486617	Armrest Kit, LH
3	486620	Seat Belt Kit
4	481638	Switch, N/O
5	486619	Track Kit
6	486618	Armrest Kit, RH
7	486624	Pad, Armrest

NOTES

SCZII SUSPENSION SYSTEM

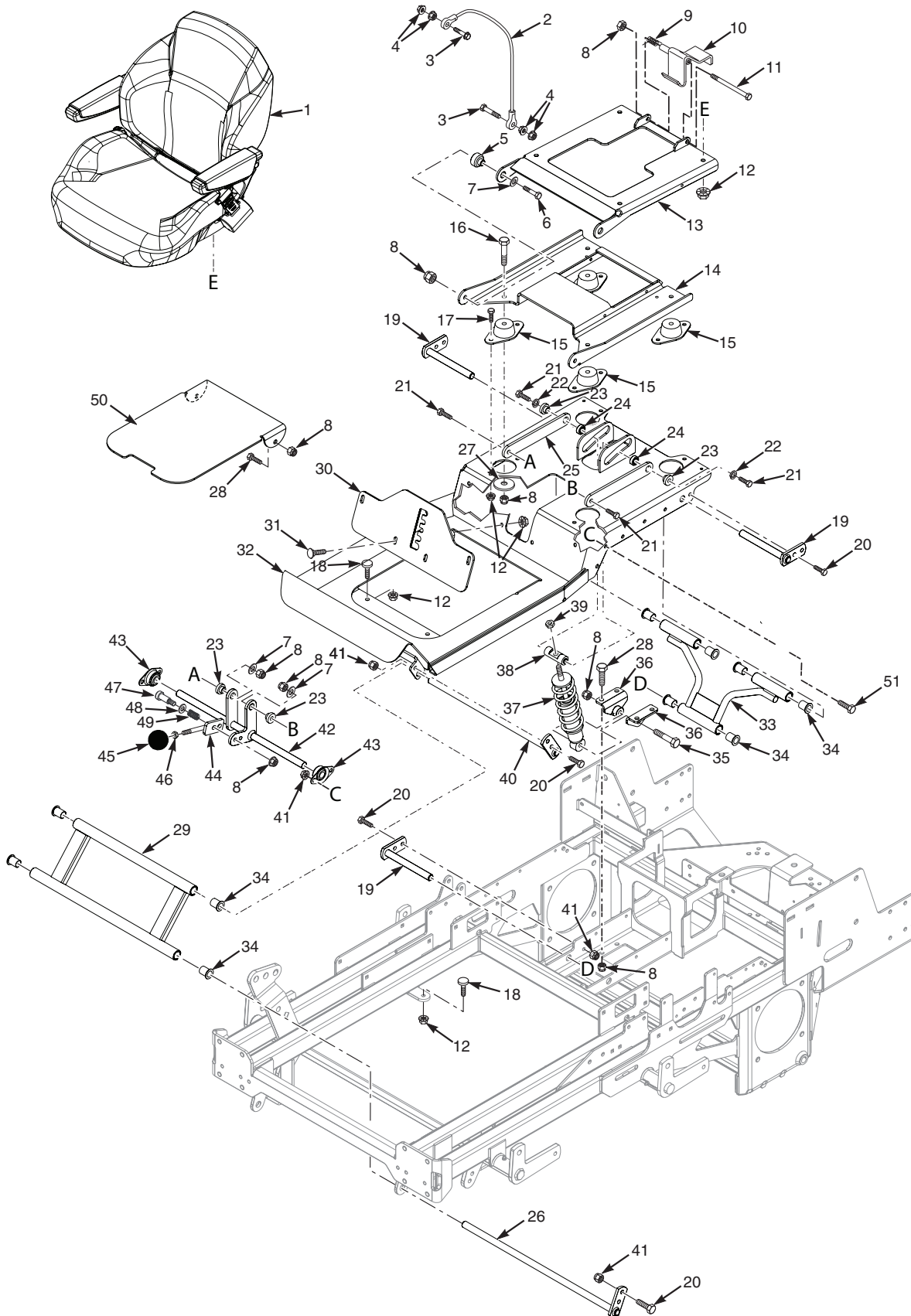

SCZII SUSPENSION SYSTEM

Ref. No.	Part No.	Description
1	486507	Seat Assembly
2	483559	Cable, Seat Stop
3	04001-59	Bolt, Hex Head 1/4-20 x 1-1/4"
4	04019-02	Nut, Serrated Flange 1/4-20
5	43606	Sleeve, Seat Base Mount
6	04001-45	Bolt, Hex Head 3/8-16 x 2"
7	04041-07	Flatwasher, 3/8-.391 x .938 x .105
8	04021-09	Nut, Elastic Stop 3/8-16
9	483371	Spring, Seat Latch
10	452143	Latch Weldment, Seat
11	04001-100	Bolt, Hex Head 3/8-16 x 6"
12	04019-03	Nut, Serrated Flange 5/16-18
13	463238	Seat Plate Weldment
14	463236	Seat Mounting Plate Weldment w/Decal
15	484148	Isolator, Seat
16	04001-46	Bolt, Hex Head 3/8-16 x 2-1/4"
17	04001-08	Bolt, Hex Head 5/16-18 x 3/4"
18	484201	Bumper, Rubber
19	452152	Shaft Weldment, Rear Op. Platform Pivot
20	04001-09	Bolt, Hex Head 5/16-18 x 1"
21	04001-20	Bolt, Hex Head 3/8-16 x 1-1/2"
22	04030-04	Lockwasher, 3/8" Spring
23	43086	Bushing
24	484035	Bearing
25	425257	Link, Suspension Seat Tensioner
26	452150	Pin Weldment, Op Platform Lower Pivot

Ref. No.	Part No.	Description
27	04041-38	Flatwasher, 3/8-.406 x 2.25 x .188
28	04001-19	Bolt, Hex Head 3/8-16 x 1"
29	463231	Suspension Pivot Assembly, Front
30	463239	Bracket, Suspension Adjustment w/Decal
31	04003-04	Bolt, Carriage 5/16-18 x 1"
32	463237	Seat Mounting Base Weldment w/Decal
33	462212	Suspension Pivot Assembly, Rear
34	483453-14	Bearing
35	04001-22	Bolt, Hex Head 3/8-16 x 2-3/4"
36	452154	Mount Weldment, Shock
37	484032	Shock Absorber, Suspension
38	484150	Mount, Suspension Shock
39	04021-18	Nut, Elastic Stop 3/8-24 Grade 8
40	452151	Pin Weldment, Op Platform Upper Pivot
41	04021-10	Nut, Elastic Stop 5/16-18
42	452107	Pivot Weldment, Suspension Tensioner
43	48796	Bearing, Self Align 5/8" ID
44	452106	Adjustment Lever, Suspension
45	484010	Knob
46	04020-12	Nut, Jam 3/8-16
47	04009-11	Bolt, Shoulder 3/8 x 1"
48	04040-05	Flatwasher, 3/8-.406 x .812 x .065
49	483601	Spring
50	428164	Cover, Foot Plate
51	04001-08	Bolt, 5/16-18 x 3/4"

SCZII STEERING COMPONENTS

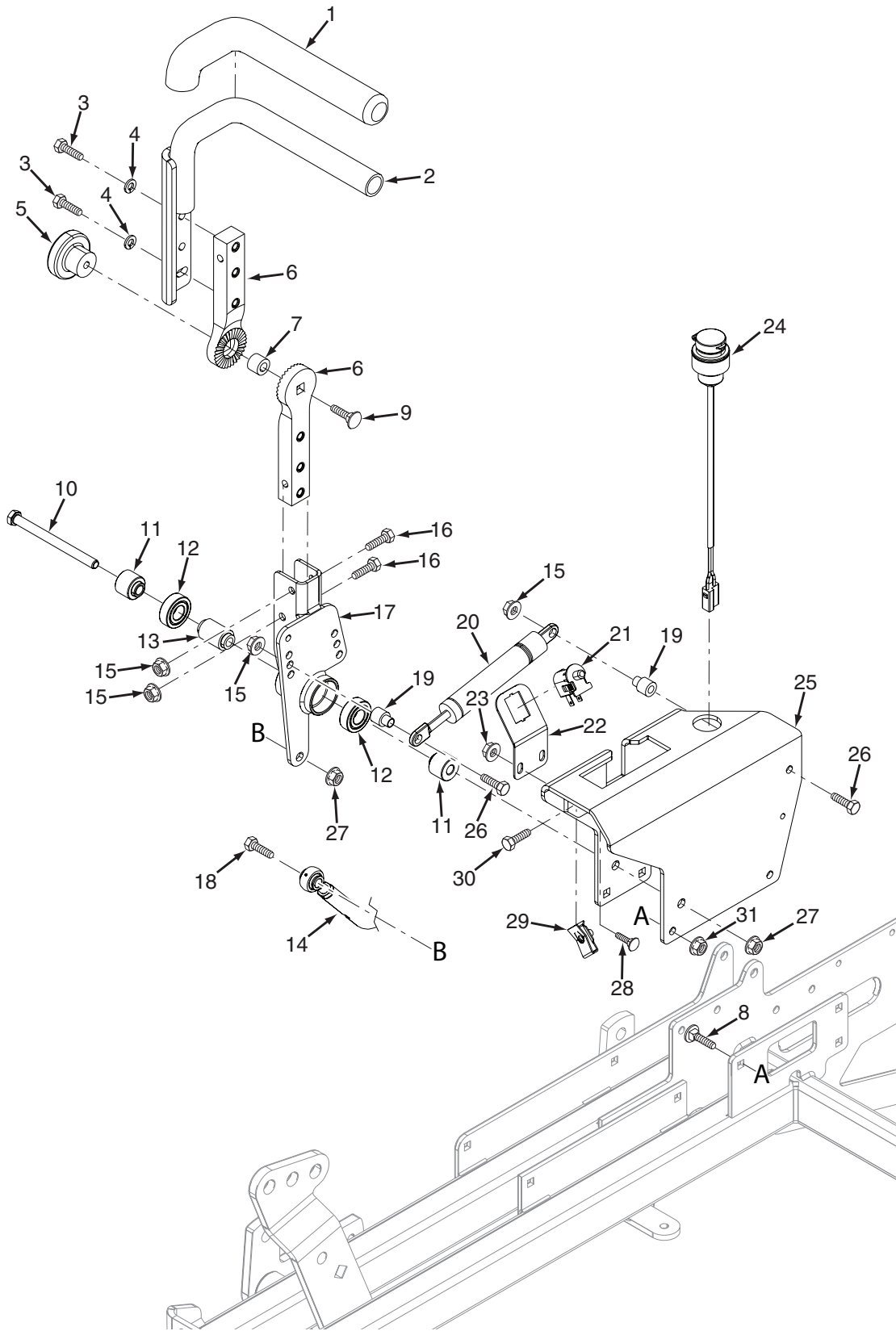

SCZII STEERING COMPONENTS

Ref. No.	Part No.	Description
1	484376	Grip, Control Lever
2	462805	Handlebar w/ Grip RH
	462804	Handlebar w/ Grip LH
3	04001-09	Bolt, 5/16-18 x 1"
4	04030-03	Lock Washer, 5/16
5	483269	Knob, Control Handle
6	483238	Pivot, Control Lever
7	483250	Spacer, Rubber
8	04003-12	Bolt, Carriage, 5/16-18 x 3/4"
9	04003-05	Bolt, Carriage, 3/8-16 x 1-1/2"
10	04001-23	Bolt, 3/8-16 x 4-1/2"
11	43607	Spacer, Controls
12	48224	Ball Bearing, Neutral Ret.
13	43600	Spacer, Bearing
14	486555	Steering Link Assembly, SCZII
	486608	Turnbuckle, 3/8-24
	486609	Rod End, Male Trunion, 3/8-24
	486610	Rod End, Female Trunion, 3/8-24
	04020-26	Nut, 3/8-24 LH Jam
	04020-25	Nut, 3/8-24 Jam
15	04021-10	Nut, Lock Elastic Stop, 5/16-18
16	04001-12	Bolt, 5/16-18 x 1-3/4"
17	453077	Pivot Weldment, Control Arm RH
	453076	Pivot Weldment, Control Arm LH
18	04001-20	Bolt, 3/8-16 x 1-1/2"
19	43602	Spacer, Pump Dampener
20	484193	Dampener, SCZII
21	481638	Switch, N/O
22	425905	Mounting Bracket, Neutral Switch
23	04117-03	Nut, Lock Flanged Elastic Stop, 1/4-20
24	485568	Power Plug, 12V
25	463234	Control Plate w/ Decals RH
	463233	Control Plate w/ Decals LH
26	04001-11	Bolt, 5/16-18 x 1-1/2"
27	04021-09	Nut, Lock Elastic Stop, 3/8-16
28	04003-02	Bolt, Carriage, 1/4-20 x 3/4"
29	04110-03	U-Nut, 3/8-16
30	04107-03	Bolt, 3/8-16 x 1-1/4" w/ Lock
31	04019-03	Nut, Serrated Flange, 5/16-18

SCZII DRIVE SYSTEM COMPONENTS

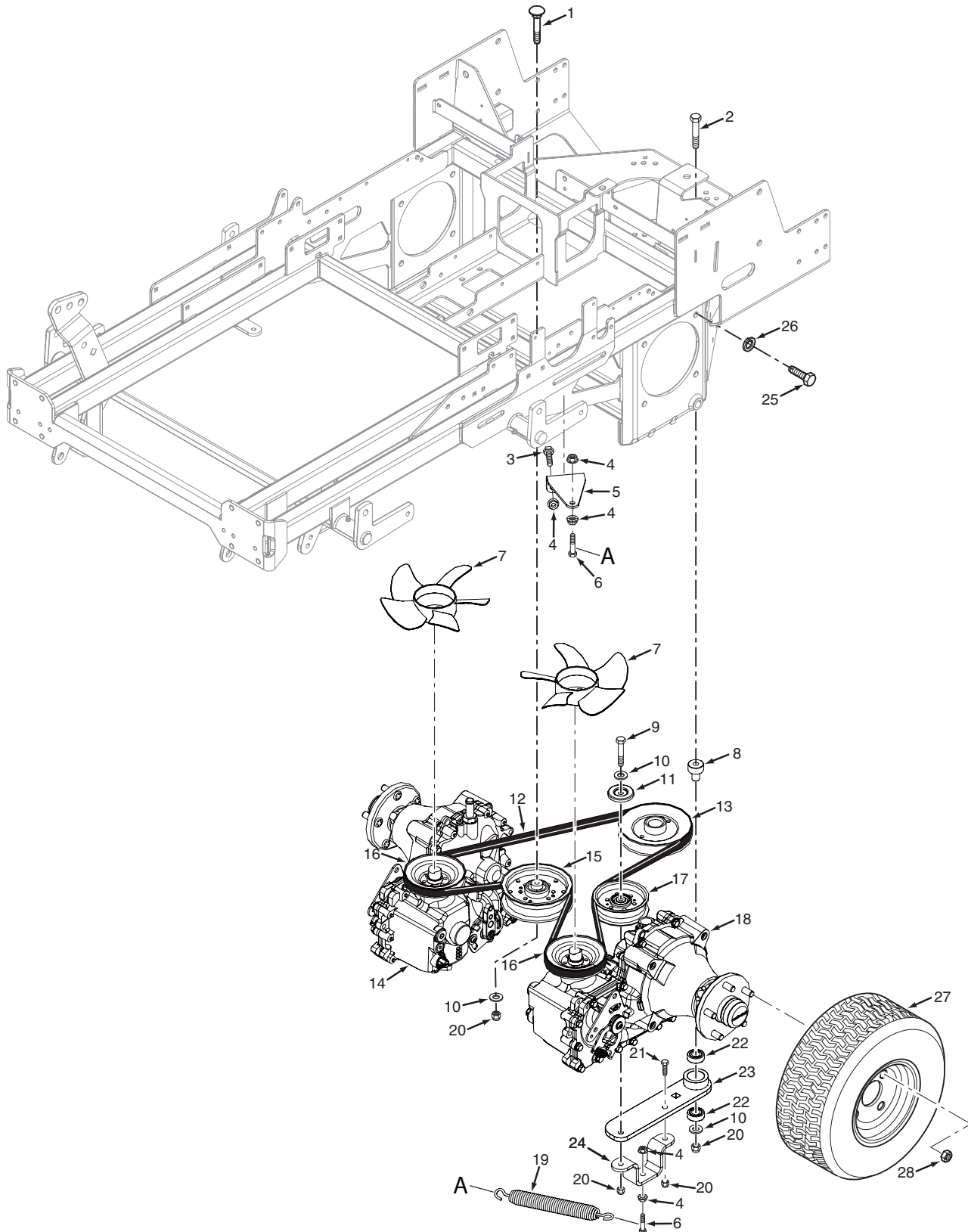

SCZII DRIVE SYSTEM COMPONENTS

Ref. No.	Part No.	Description
1	04003-21	Bolt, Carriage 3/8-16 x 2-1/2"
2	04001-54	Bolt, Hex Head 3/8-16 x 3"
3	04001-19	Bolt, Hex Head 3/8-16 x 1"
4	04019-04	Nut, Serrated Flange 3/8-16
5	425385	Mounting Bracket, Spring - Idler Arm
6	04001-136	Bolt, Hex Head 3/8-16 x 1-1/2" Grade 8
7	HG71906	Kit, Fan / Pulley
8	43504	Pivot, Idler Long
9	04001-22	Bolt, Hex Head 3/8-16 x 2-3/4"
10	04043-04	Flatwasher, 3/8-.391 x .938 x .105 HD
11	424367	Dust Shield
12	483165	Belt, Pump Drive
13	484098	Pulley, 5.80" Dia. - 1.125 Bore
14	483798	Transaxle, RH
15	483215	Pulley, 5" Dia. Idler
16	HG71906	Kit, Fan / Pulley
17	484128	Pulley, 4" Dia. Idler
18	483797	Transaxle, LH
19	484202	Spring, Idler Arm
20	04021-09	Nut, Elastic Stop 3/8-16
21	04001-32	Bolt, Hex Head 3/8-16 x 1-1/4"
22	48224	Bearing
23	462259	Idler Arm Assembly (incl. # 22)
24	425386	Mounting Bracket, Idler
25	04001-70	Bolt, Hex Head 1/2-13 x 1-1/4"
26	04030-06	Lockwasher, 1/2" Spring
27	484024	Wheel Assembly, 24 x 12-12 4-Ply (5-Hole)
	484023	Rim w/Valve Stem
	481852	Tire, 24 x 12-12 4-Ply
28	04028-02	Lug Nut, 1/2-20

SCZII SPEED CONTROL COMPONENTS

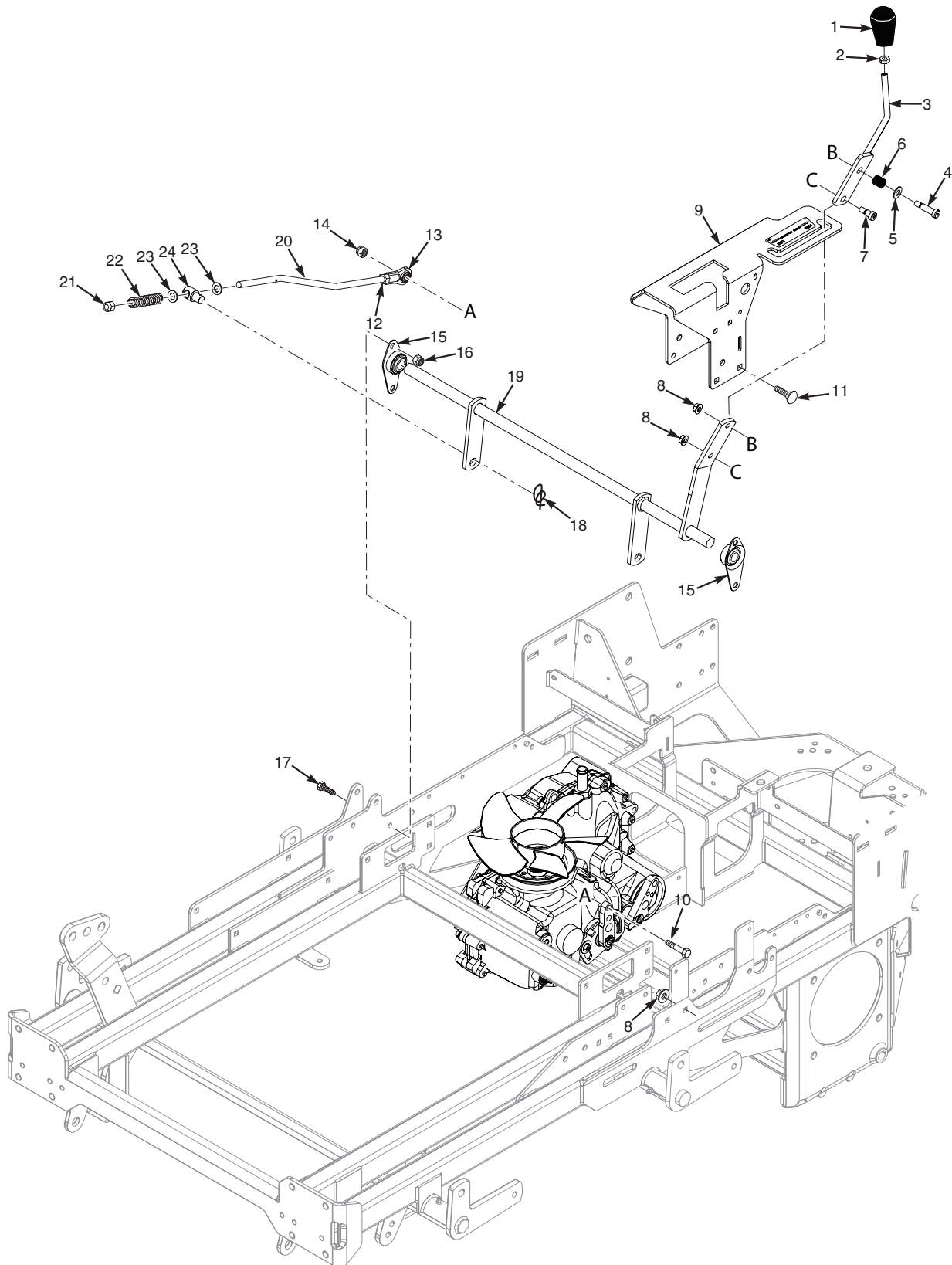

SCZII SPEED CONTROL COMPONENTS

Ref. No.	Part No.	Description
1	484093	Knob, Soft Touch
2	04020-12	Nut, Jam 3/8-16 UNC
3	453097	Lever Weldment, Speed Control SCZII
4	04009-11	Bolt, Shoulder 3/8 x 1"
5	04040-05	Flatwasher, 3/8-.406 x .812 x .065
6	483601	Spring, Speed Control
7	04009-14	Bolt, Shoulder 3/8 x 3/8"
8	04019-03	Nut, Serrated Flange 5/16-18
9	463233	Control Weldment w/ Decals
10	04001-10	Bolt, Hex Head 5/16-18 x 1-1/4"
11	04003-12	Bolt, Carriage, 5/16-18 x 3/4"
12	04020-14	Nut, 3/8-24 UNF Jam
13	484177	Rod End, 3/8-24
14	04021-04	Nut, Lock Center Lock, 5/16-18
15	484149	Bearing, Self Align
16	04117-01	Nut, FLG HH Elastic Stop 5/16-18
17	04001-08	Bolt, Hex Head 5/16-18 x 3/4"
18	04069-02	Pin, Rue Cotter 1/2" Dia.
19	453066	Speed Control Bellcrank Weldment
20	486500	Speed Linkage Assembly (INCL. 12,13,21,22
21	04021-27	Nut, Elastic Stop 3/8-24
22	484175	Spring
23	04041-45	Flatwasher, 3/8-.376/.380 x .734 x .063
24	485317	Bushing, Pivot

SCZII BRAKE COMPONENTS

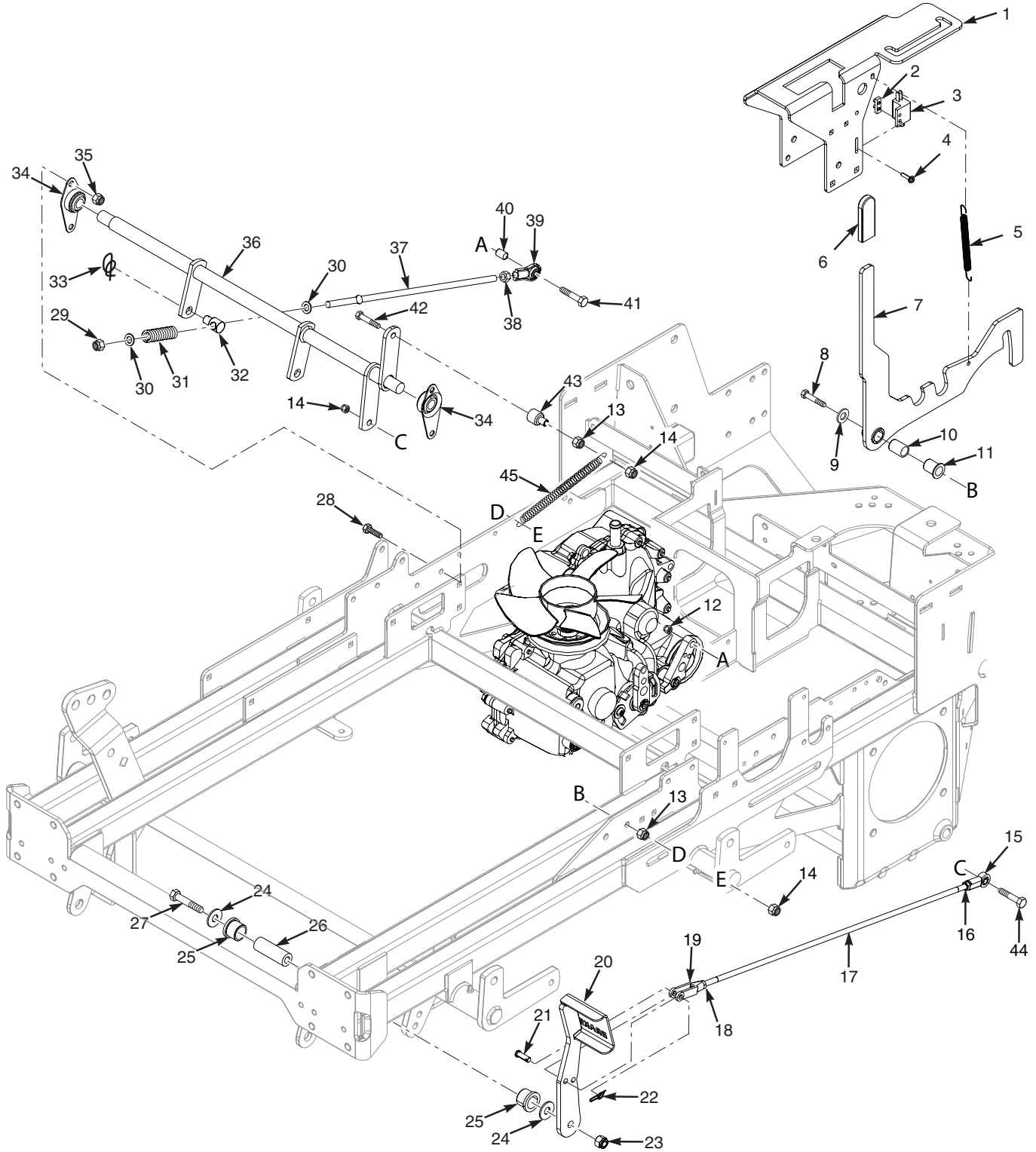

SCZII BRAKE COMPONENTS

Ref. No.	Part No.	Description
1	463233	Control Weldment w/ Decal
2	422373	Plate, Threaded
3	486616	Switch, N/C
4	04010-12	Screw, #10-32 x .75
5	483600	Spring, Brake
6	482102	Grip, Brake Lever
7	463192	Brake Lever w/ Grip
8	04001-31	Bolt, 3/8-16 x 2-1/2"
9	04043-04	Flat Washer, 3/8 - .391 x .938 x .105
10	431047	Pivot, Brake Lever
11	483453-14	Bearing, .625 ID
12	04021-04	Nut, Lock Center Lock, 5/16-18
13	04021-05	Nut, Lock Center Lock, 3/8-16
14	04021-09	Nut, Lock Elastic Stop, 3/8-16
15	48544	Rod End, 3/8-24 LH Thd
16	04020-26	Nut, 3/8-24 LH Jam
17	486575	Brake Rod Assembly (INCL. 15,16,18,19)
18	04020-25	Nut, 3/8-24 Jam
19	48343-04	Clevis, 3/8-24
20	453138	Brake Pedal
21	04064-02	Clevis Pin, 3/8 x 1.06
22	04069-01	Pin, Rue Cotter - 3/8 Dia
23	04021-07	Nut, Lock Elastic Stop, 1/2-13
24	04040-13	Flat Washer, 1/2- .562 x 1.375 x .109
25	483453-03	Bearing, 1" ID
26	43872	Sleeve, Brake Pivot
27	04001-194	Bolt, 1/2-13 x 4-1/4"
28	04001-08	Bolt, 5/16-18 x 3/4"
29	04021-27	Nut, Lock Elastic Stop, 3/8-24
30	04041-45	Flat Washer, 3/8 - .376/.380 x .734 x .063
31	484182	Spring, Lower Brake
32	485317	Bushing, Pivot Slide
33	04069-02	Pin, Rue Cotter - 1/2" Dia
34	484149	Bearing, Self Align
35	04117-01	Nut, Lock Flange Elastic Stop, 5/16-18
36	453067	Brake Linkage Weldment
37	485321	Brake Linkage Assembly (INCL. 29,30,31,32,38,39)
38	04020-14	Nut, 3/8-24
39	484177	Rod End, 3/8-24 Thd 5/16 Bore
40	43749	Spacer, V-link
41	04001-195	Bolt, 5/16-18 x 2-1/2"
42	04001-22	Bolt, 3/8-16 x 2-3/4"
43	43503	Pivot, Idler - Short
44	04001-26	Bolt, 3/8-16 x 1-1/4"
45	481343	Spring, Hopper Door

SCZII HYDRAULIC SYSTEM

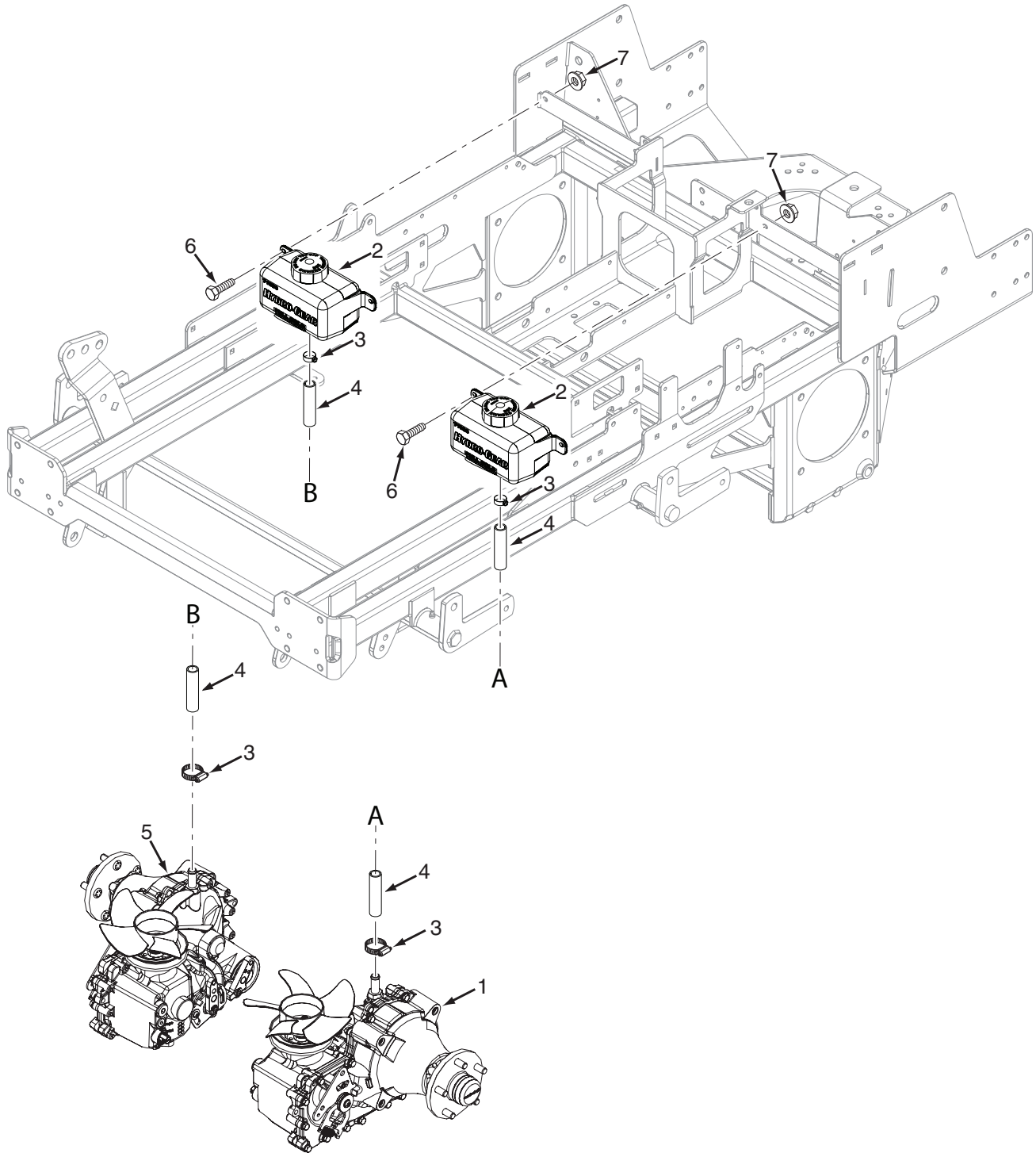

SCZII HYDRAULIC SYSTEM

Ref. No.	Part No.	Description
1	483797	Transaxle, LH
2	486568	Hydraulic Tank, 1,000 ml
3	48136-16	Clamp, 1" Max Dia.
4	48504	Hose, 5/8 Pushlock (order by inch)
5	483798	Transaxle, RH
6	04001-01	Bolt, 1/4-20 x 3/4"
7	04019-02	Nut, Serrated Flange, 1/4-20

SCZII FUEL SYSTEM

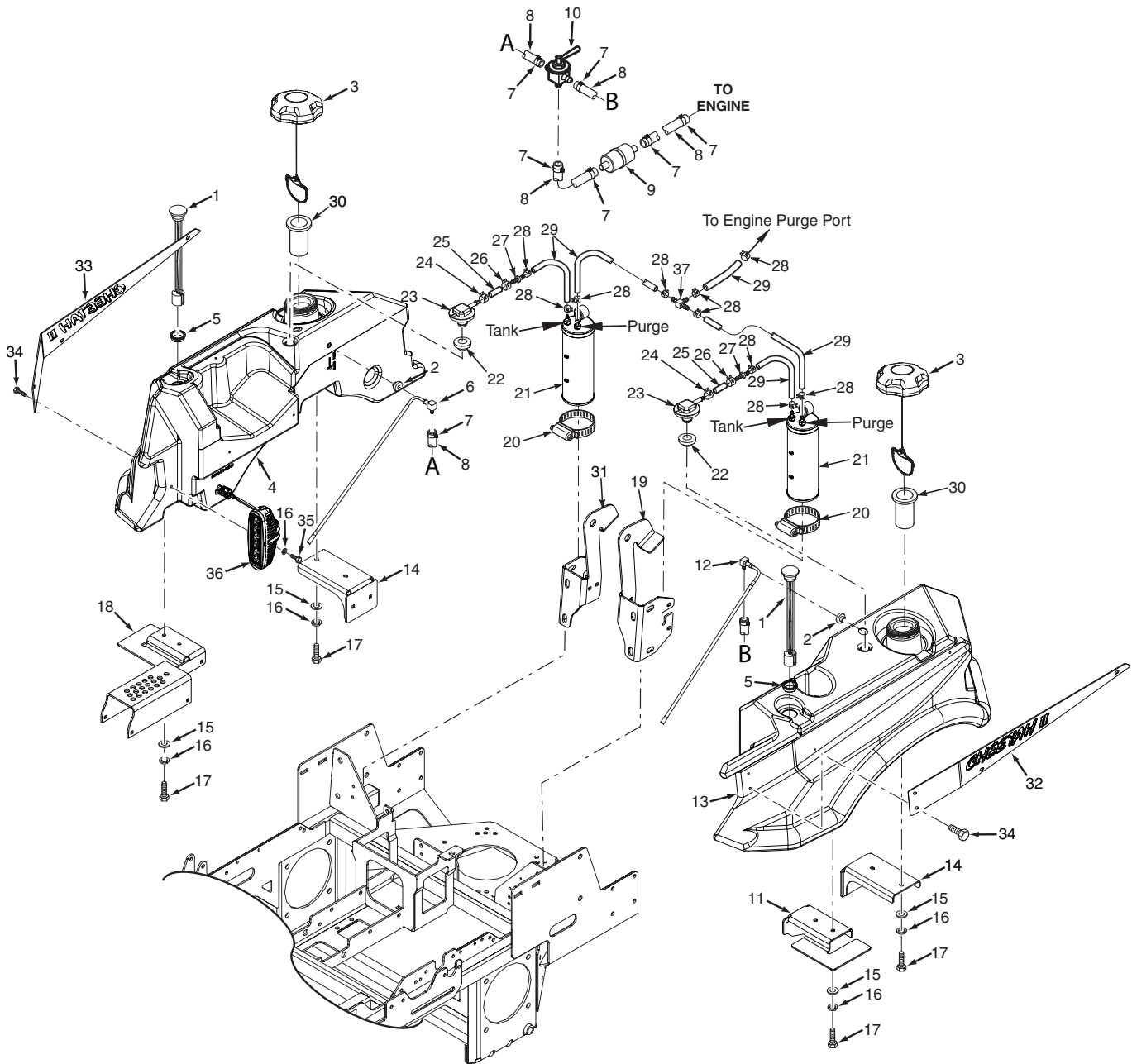

SCZII FUEL SYSTEM

Ref. No.	Part No.	Description
1	484243	Fuel Gauge
2	482571	Bushing, .56 Dia. Viton
3	484286	Fuel Cap, Tethered
	484297	Fuel Cap w/Tethered - California Models Only (not shown)
4	463273	Fuel Tank Assembly, RH (incl. #1, 2, 5, 6, 22, 23)
5	484242	Grommet
6	484553	Fuel Tube Assembly, RH
7	48059-01	Clamp, Fuel Hose 1/4" ID
8	483617	Fuel Hose, 1/4" Non-Perm (order by inch)
9	**	Fuel Filter
10	482212	Valve, Fuel Shut-Off
11	428233	Mounting Bracket, Fuel Tank Front
12	484552	Fuel Tube Assembly, LH
13	463272	Fuel Tank Assembly, LH (incl. #1, 2, 5, 12, 22, 23)
14	428261	Mounting Bracket, Fuel Tank Rear
15	04040-15	Flatwasher, 5/16-.375 x .875 x .083
16	04030-03	Lockwasher, 5/16" Spring
17	04001-08	Bolt, Hex Head 5/16-18 x 3/4"
18	463235	Adjustment Bracket, Upper Cut Height
19	427177	Rops Mounting Bracket LH
20	48136-17	Clamp
21	484342	Carbon Canister
	484366	Dust Filter, Carbon Canister
22	484285	Grommet, Viton
23	484333	Remote Vent
24	48059-02	Clamp, Fuel Hose 7/32"
25	484347	Hose, 1/4" Vapor Recovery (order by inch)
26	48059-02	Clamp, Fuel Hose 7/32"
27	484343-01	Mender, 1/4 x 3/16 w/.02 Hole
28	48059-05	Clamp, Vapor Recovery Hose 3/16"
29	484345	Hose, 3/16"
30	484279-01	Tube, Fuel Tank Insert
31	427178	Rops Mounting Bracket RH
32	428229	Plate, LH Fuel Tank
33	428195	Plate, RH Fuel Tank
34	04017-04	Bolt, Serrated Flange 1/4-20 x 1/2"
35	04015-11	Screw, 5/16-18 x 3/4"
36	486672	Light Assembly
37	48935-02	Tee, 3/16 x 3/16 x 3/16 Union - Hose Barb

** Available through the individual engine manufacturer.

SCZII ENGINE & ATTACHING PARTS

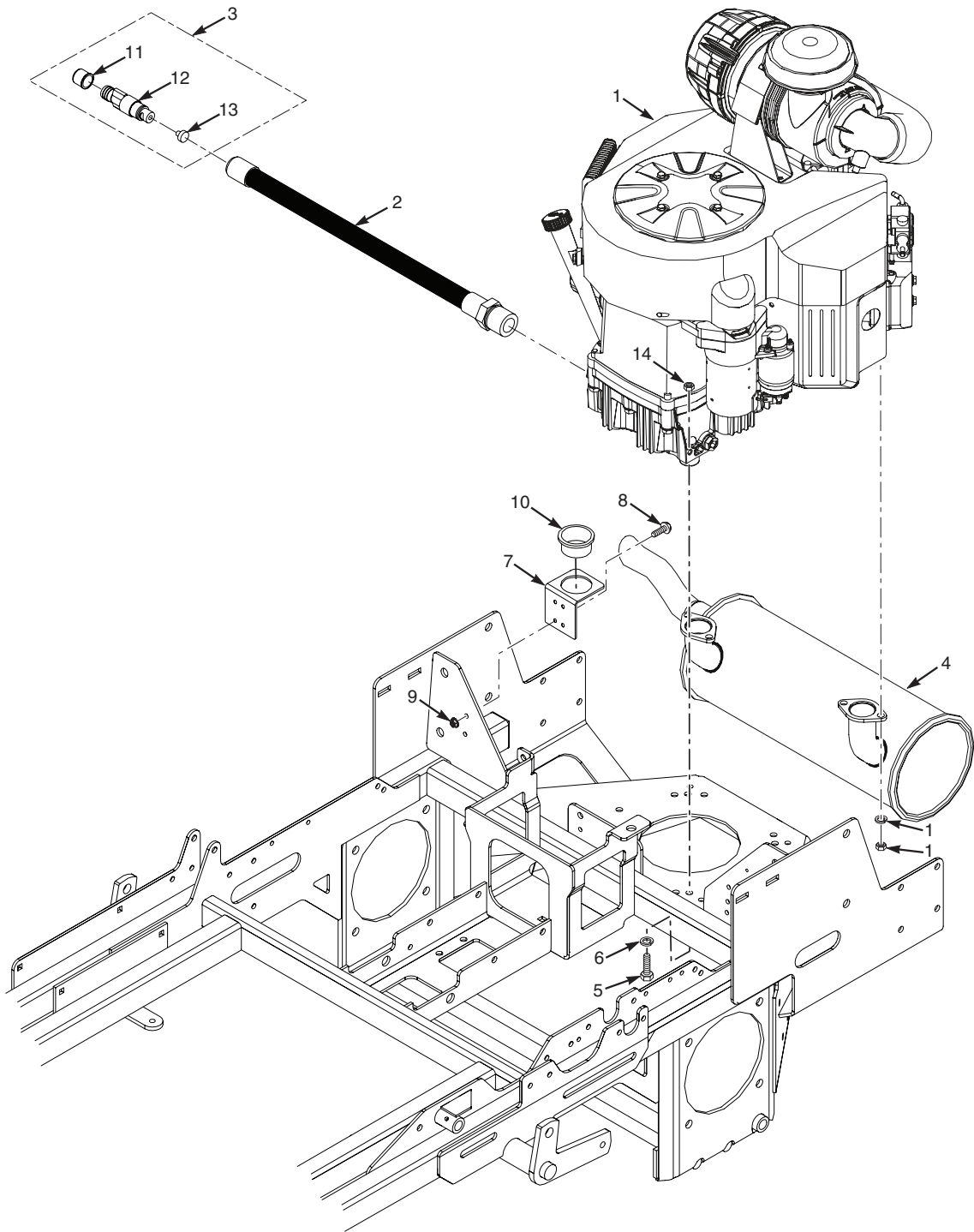

SCZII ENGINE & ATTACHING PARTS

Ref. No.	Part No.	Description
1	**486726	Engine, Kawasaki 38FX-EFI (FX1000)
	**486516	Engine, Briggs & Stratton 37 BV-EFI (61E8770002J1)
2	484581	Hose, Oil Drain, Kawasaki (incl. # 3)
	484599	Hose, Oil Drain, Briggs & Stratton (incl. # 3)
3	484583	Valve Assembly, Oil Drain
4	486648	Muffler, Kawasaki - FX921
	*486660	Pipe, Muffler Extension - FX921
	*48633	Muffler Clamp - FX921
	486108	Muffler, Briggs & Stratton - 37 BV-EFI
	*486659	Pipe, Muffler Extension - 37 BV-EFI
	*484291	Clamp, Muffler - 1-3/4" - 37 BV-EFI
	04001-32	Bolt, 3/8-16 x 1-1/4"
5	04001-20	Bolt, 3/8-16 x 1-1/2" (37BV-EFI)
	04030-04	Lockwasher, 3/8" Spring (31FX)
6	425975	Bracket, Oil Drain Hose
7	04010-32	Screw, #8-32 x 5/8"
8	04021-17	Nut, Elastic Stop #8-32
9	484617	Bushing, Thick Panel Snap
10	484585	Cap
11	48603-12	O-Ring
12	484586	Seal
13	04134-03	Nut, Lock Flange Top Lock, 3/8-16 (37BV-EFI)
14		

* Not Shown

** Available through the individual engine manufacturer.

ZT-5400 TRANSAXLE ASSEMBLY

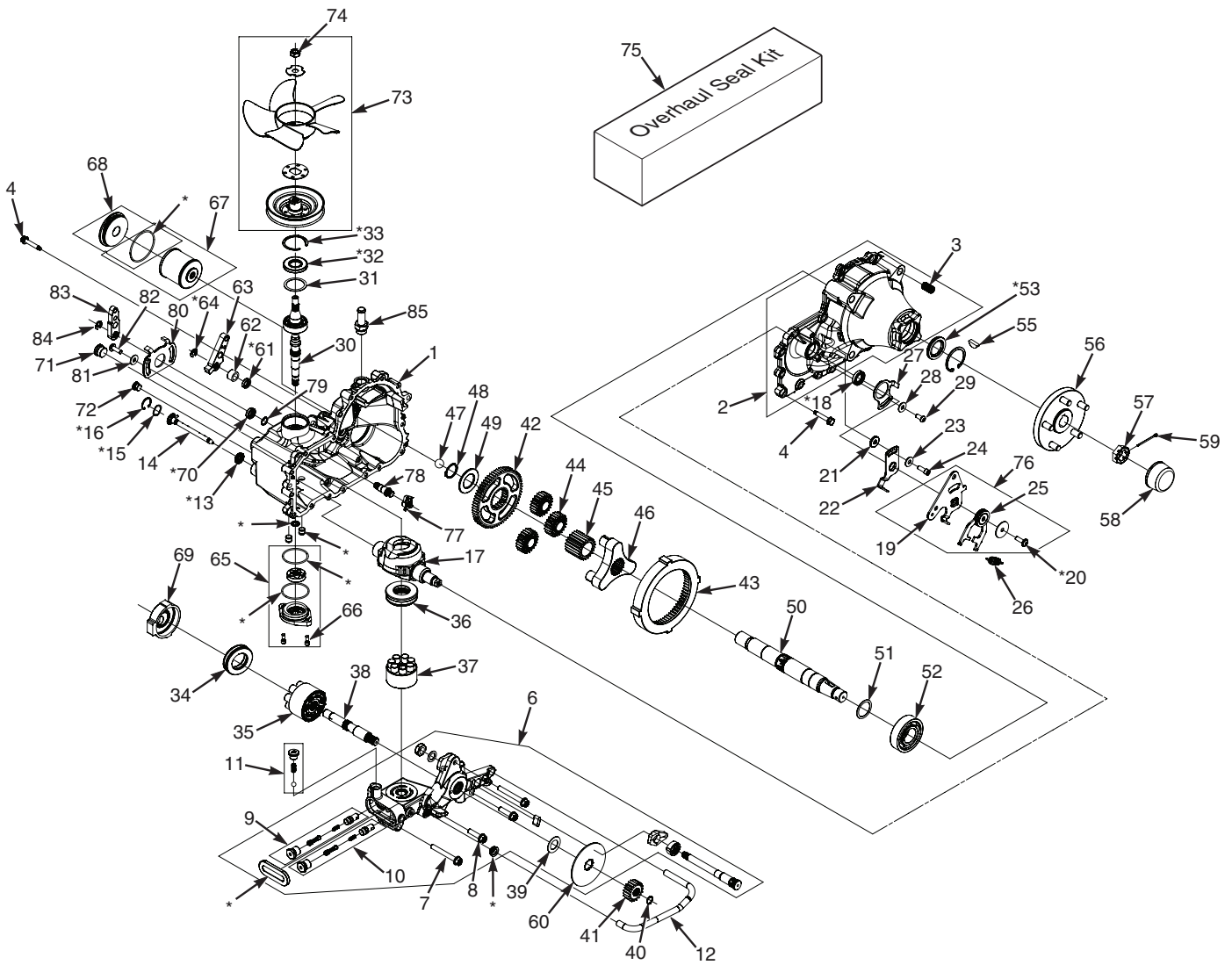

* - Included with Seal Kit Item # 75

ZT-5400 TRANSAXLE ASSEMBLY

Ref. No.	Part No.	Description
1	HG71946	Kit, Housing Main, LH
	HG71947	Kit, Housing Main, RH
2	HG71948	Kit, Housing Side, LH
	HG71948	Kit, Housing Side, RH
3	HG52973	Insert, 1/2-13 x 1-1/2" UNC
4	HG52974	Screw, Hex Flange 5/16-18 x 1-1/2"
5	HG50928	Tube, Sealant
6	HG71995	Kit, Center Section, LH
	HG71996	Kit, Center Section, RH
7	HG52977	Bolt, Hex Flange 3/8-16 x 3"
8	HG52137	Screw, Hex Flange Head 3/8-16 x 1-1/2"
9	HG71952	Kit, Shock Valve
10	HG71952	Kit, Shock Valve
11	HG71999	Kit, Charge Relief
12	HG52984	Tube, Filter, LH
	HG52983	Tube, Filter, RH
13	HG53197	Seal, Lip 12x 24 x 5 TC
14	HG71940	Kit, Bypass Actuator
15	HG53321	Spring, Wave
16	HG53322	Ring, Retaining, HO-100
17	HG52972	Swash Plate, 16cc. Machined
18	HG52989	Seal, Lip 22 x 32 x 7
19	HG53222	Arm, Control, LH
	HG53221	Arm, Control, RH
20	HG51812	TWHCS, 5/16-18 x 1" (Patch)
21	HG52527	Spacer, .320 x 1.005 x .179
22	HG51946	Arm, Neutral, LH
	HG51945	Arm, Neutral, RH
23	HG44130	Washer, .34 x .88 x .06
24	HG51616	SHCS, 5/16-24 x .875 (Patch)
25	HG52433	Assembly, RTN Uni-Directional (CCW) LH
	HG52434	Assembly, RTN Uni-Directional (CW) RH
26	HG51605	Spring, Extension, RTN - 44lbs
27	HG53190	Plate, Stop, LH
	HG53189	Plate, Stop, RH
28	HG44130	Washer, .34 x .88 x .06
29	HG53519	HBHCS, 5/16-18 x 3/4"
30	HG71941	Kit, Input Shaft
31	HG51279	Spacer
32	HG51280	Seal, Lip 25 x 52 x 7 TC
33	HG52650	Ring, Retaining Internal
34	HG53341	Bearing, Thrust 42 x 68 x 16
35	HG70082	Kit, Cylinder Block - 21cc.
36	HG52991	Bearing, Thrust 35 x 70 x 22
37	HG70735	Kit, Cylinder Block - 16cc.
38	HG52992	Shaft, Motor
39	HG52993	Washer, .89 x 1.50 x .04
40	HG44145	Ring, Retaining
41	HG52994	Gear, 19T
42	HG52996	Gear, 65T
43	HG52998	Gear, Ring 68T
44	HG52999	Gear, Planet 23T
45	HG53000	Gear, Sun 22T

Ref. No.	Part No.	Description
46	HG53001	Carrier
47	HG53002	Ball, Thrust .75
48	HG53003	Ring, Retaining 1-1/4"
49	HG53004	Spacer, Thrust, Axle
50	HG53005	Shaft, Axle
51	HG53006	Washer, 1.40 x 1.75 x .05
52	HG53007	Bearing, Ball 35 x 80 x 21
53	HG53008	Seal, Lip 1.375 x 2.062 x .250
54	HG50859	Ring, Retaining Internal
55	HG51796	Key, Shaft, Axle
56	HG72039	Kit, Hub, 5-Bolt
57	HG51821	Nut, Hex 1-20 Slotted
58	HG53724	Cap, Axle
59	HG51822	Pin, Cotter 9/64 x 2"
60	HG53012	Rotor, Brake
61	HG53015	Seal, .56 x .88 x .19
62	HG53356	Spacer, .57 x .86 x .53
63	HG53018	Handle, Actuating
64	HG53019	Ring, Retaining
65	HG71942	Kit, Charge Cover
66	HG9007300-2510	Screw, 1/4-20 x .625
67	HG71943	Kit, Filter
68	HG71944	Kit, Filter Plug
69	HG53026	Plate, Motor Swash
70	HG9008000-0127	Seal, 15 x 24 x 7
71	HG9005110-8700	Plug, 7/8-14
72	HG9005110-5600	Plug, 9/16-18
73	HG71906	Kit, Fan/Pulley
74	HG44133	Nut, Hex 1/2-20 w/Patch
75	HG71945	Seal Kit
76	HG72002	Kit, RTN Bi-Directional LH
	HG72001	Kit, RTN Bi-Directional RH
77	HG53028	Cam, 2-Speed
78	HG53029	Shaft, 2-Speed, Bevel
79	HG53030	Ring, Retaining External .59"
80	HG53034	Arm, Lock Down 2-Speed
81	HG44130	Washer, .34 x .88 x .06
82	HG53519	HBHCS, 5/16-18 x 3/4"
83	HG53193	Handle, Actuating
84	HG53019	Ring, Retaining External .375"
85	HG53037	Fitting, 7/8-14 SAE, .625 Beaded

SCZII EFI ELECTRICAL SYSTEM

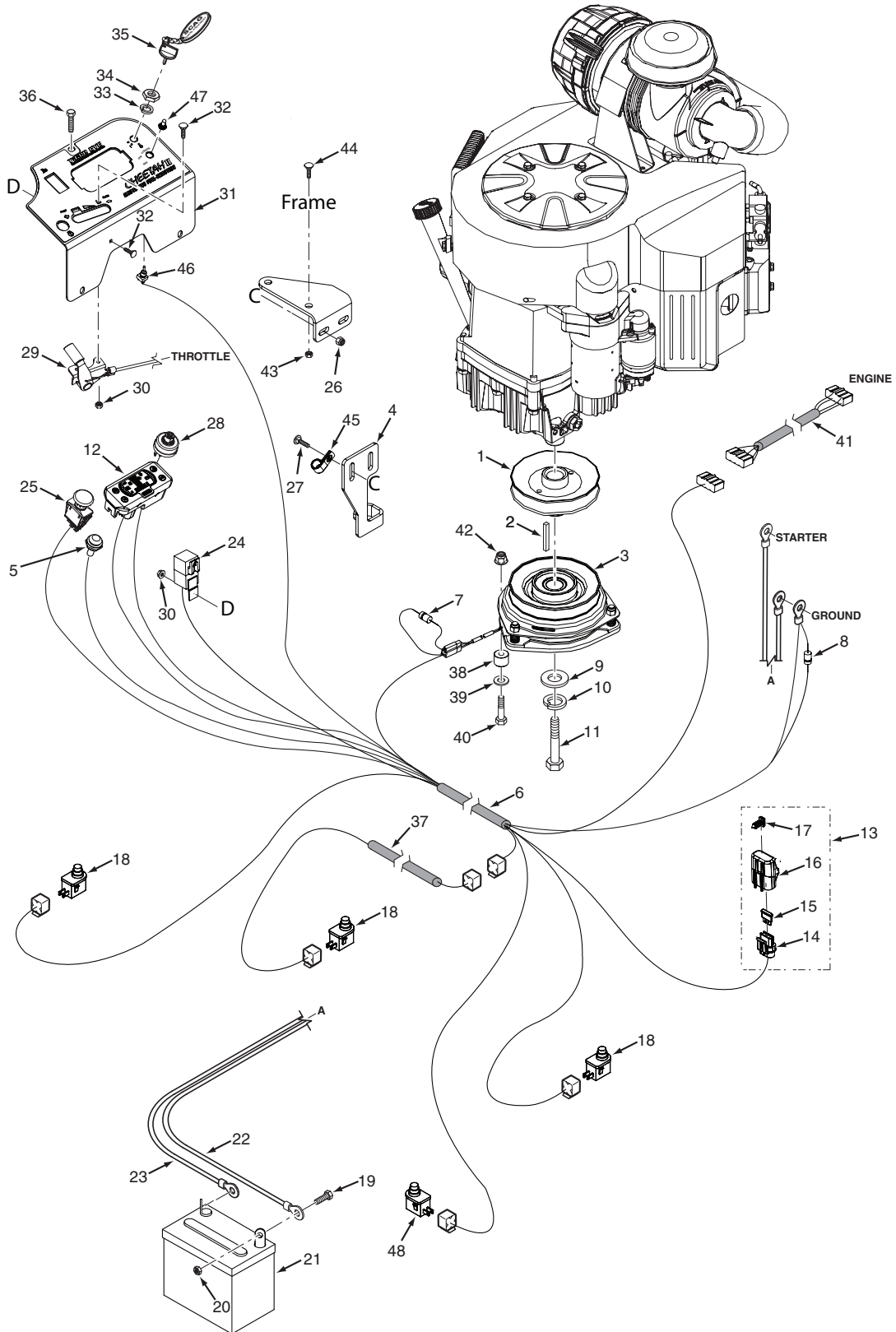

SCZII EFI ELECTRICAL SYSTEM

Ref. No.	Part No.	Description
1	484098	Pulley, 5.80 Dia. - 1.125 Bore
2	04063-23	Key, 1/4 x 1/4 x 3-1/4"
3	461826	Electric Clutch w/Tag - GT-5
4	426950	Bracket, Anti-Rotation
5	481182	Indicator Light Assembly
6	486508	Wire Harness, SCZII-EFI
7	483958	Diode, 600V - 6A
8	482253	Diode
9	04041-28	Flatwasher, 7/16-.469 x 1.75 x .25
10	04030-05	Lockwasher, 7/16" Spring
11	04102-03	Bolt, Hex Head 7/16-20 x 2-1/4" w/Patch
12	484721	Tiger Eye Cluster Gauge
13	485739	Fuse Assembly (incl. # 14, 16, 17)
14	483629	Fuse Holder
15	48298	Fuse, 20 Amp
16	483643	Cover, Sealed Single
17	482588	Clip, Wire
18	481638	Switch, N.O.
19	04001-44	Bolt, Hex Head 1/4-20 x 1/2"
20	04020-02	Nut, 1/4-20
21	*	Battery
22	48029-07	Battery Cable, 18" Black
23	48029-28	Battery Cable, 25" Red
	**48126	Rubber Boot
24	483013	Relay
25	485833	Switch, PTO - 10 Amp
26	04117-01	Nut, FLF HH Elastic Stop 5/16-18
27	04003-04	Bolt, Carriage 5/16-18 x 1"
28	48798	Keyswitch w/Hardware
29	481544	Control Cable
30	04021-26	Nut, Elastic Stop #10-24
31	463240	Instrument Panel w/Decal
32	04003-43	Bolt, Carriage #10-24 x 1/2"
33	48017-03	Lockwasher, 5/8" Internal
34	48017-04	Nut, Hex 5/8-32
35	462069	Key Assembly w/Fob
36	04017-04	Bolt, Hex Head 1/4-20 x 1/2" Serrated Flange
37	484722	Wire Harness, Operator Platform -SCZII
38	431009	Bushing, UHMW
39	04040-15	Flatwasher, 5/16-.375 x .875 x .083
40	04001-11	Bolt, Hex Head 5/16-18 x 1-1/2"
41	486139	Wire Harness Adapter, Briggs & Stratton 37 BV-EFI
42	04021-10	Nut, Lock Elastic Stop, 5/16-18
43	04019-04	Nut, Serrated Flange, 3/8-16
44	04003-23	Bolt, Carriage, 3/8-16 x 1"
45	48030-09	Clamp, Cable - 1/2" ID
46	483120	Switch, On/Off
47	483121	Boot, Switch
48	486616	Switch, N/C

* Not available through Scag

** Not Shown

REPLACEMENT DECALS AND INFORMATION PLATES



1

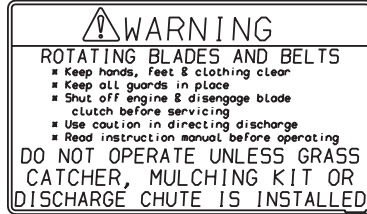

2

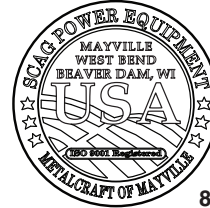

8

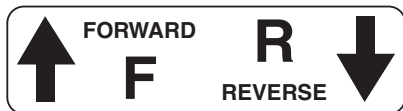

6

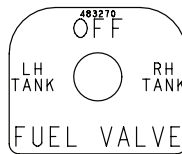

10



3



9

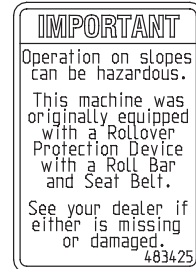

5

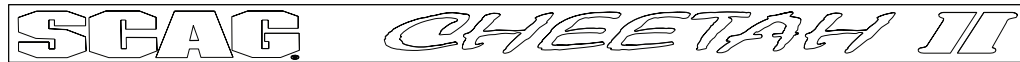

11

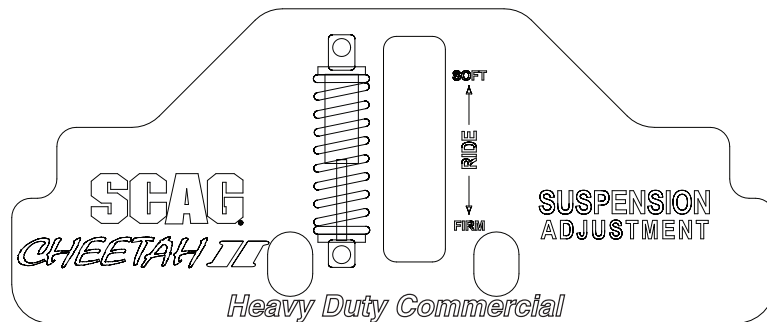

12



13



14

<p><i>Always use original Scag replacement parts for top machine performance and to maintain factory warranty.</i></p>	<p>SCAG Replacement Parts Numbers CHEETAH II</p>	
	<p>Ball, Pump Drive (81772) 483185</p>	<p>Standard Blade, Cutter (817) 482861</p>
	<p>Ball, Cutter Deck (817) 483741</p>	<p>Standard Blade, Cutter (72) 482862</p>
	<p>Ball, Cutter Deck, Right Side (817) 483157</p>	<p>Spline Grease: Mobilgrease XHP™ 222 Econ Mobil Romax MP Econ Mobil Unifex EP2</p>
	<p>Ball, Cutter Deck (72) 484088</p>	<p>Filac Hydraulic (81772) H3F1843</p>
<p>Ball, Cutter Deck, Right Side (72) 484189</p>		
<p>See your authorized Scag dealer for engine part numbers. <small>pn 48899</small></p>		

19

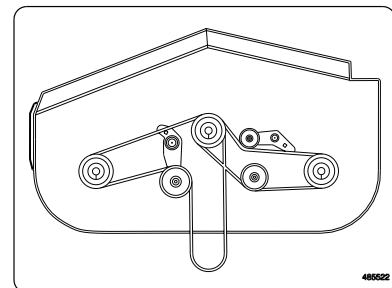

486622

20

REPLACEMENT DECALS AND INFORMATION PLATES

Ref. No.	Part No.	Description
1	483407	Decal, Spinning Blades
2	483406	Decal, Knives
3	483201	Decal, 61" Velocity Plus
	484574	Decal, Velocity Plus - 61RD
	483693	Decal, 72" Velocity Plus
4	483633	Decal, Seat Replacement
5	483425	Decal, ROPS
6	482100	Decal, Traction Control
7	483405	Decal, Warning
8	485403	Decal, Made in USA
9	483402	Decal, Belt Cover
10	483270	Decal, Fuel Shut Off
11	486582	Decal, Scag Cheetah II
12	486580	Decal, Suspension Adjustment
13	484134	Decal, Deck Height - LH
14	484135	Decal, Deck Height - RH
15	486510	Decal, Instrument Panel - SCZII - EFI
16	486613	Decal, Speed Control
17	483443	Decal, Start / Drive
18	486612	Decal, Adjustments - SCZII
19	486581	Decal, SCZII Replacement Parts
20	485522	Decal, SCZII Belt Routing
	485523	Decal, SCZII Belt Routing 61RD
21	486559	Decal, Scag - Fuel Tank
**	483900	Decal, Warning Spark Arrestor (California Models Only - not shown)
**	01411	DVD Video, Tips for Safe Operation of Your Scag Zero-Turn Mower

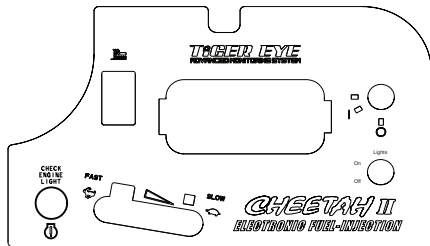

15



16

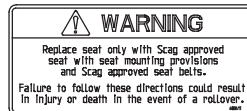

4



7

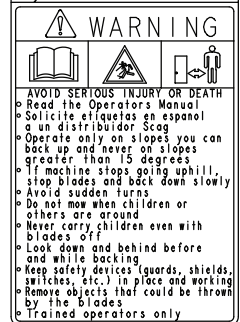

17

IMPORTANT ADJUSTMENT PROCEDURES
READ OPERATORS MANUAL FOR MORE DETAILS
Check tire pressure-SCZII-61/72 Drive tires-12 psi
Caster tires-Flat Free

FREE WHEEL OPERATION
To move machine without running engine, turn valve on LH & RH transaxles from RUN to BY-PASS. (See operator's manual)

NEUTRAL ADJUSTMENT

ALIGN TABS

To re-set neutral, have engine off and control levers in neutral. Remove rear wheels. Adjust linkage turnbuckle until tabs on transaxle align. Repeat for opposite side. If wheels still creep after adjustment, see an authorized Scag dealer.

HYDRAULIC FLUID LEVEL
Check hydraulic fluid level while fluid is cool. Fluid level should be at full cold line on tanks. Fill with 20W50 motor oil only.

IMPORTANT
Do not overfill. Room for hot fluid expansion must be allowed or resulting expansion may cause leaks in the system.

CONTROL LEVER
Stop Bolt

TRACKING ADJUSTMENT

If machine pulls to right, adjust LH control stop bolt CW (Inward) to slow left wheel down.
If machine pulls to left, adjust RH control stop bolt CW (Inward) to slow right wheel down.

486612

18



21

SCZII BV - EFI ELECTRICAL SCHEMATIC

(shown with Key Off, PTO Off, Park Brake Applied, Control Handles in Neutral, Seat Switch Disengaged)

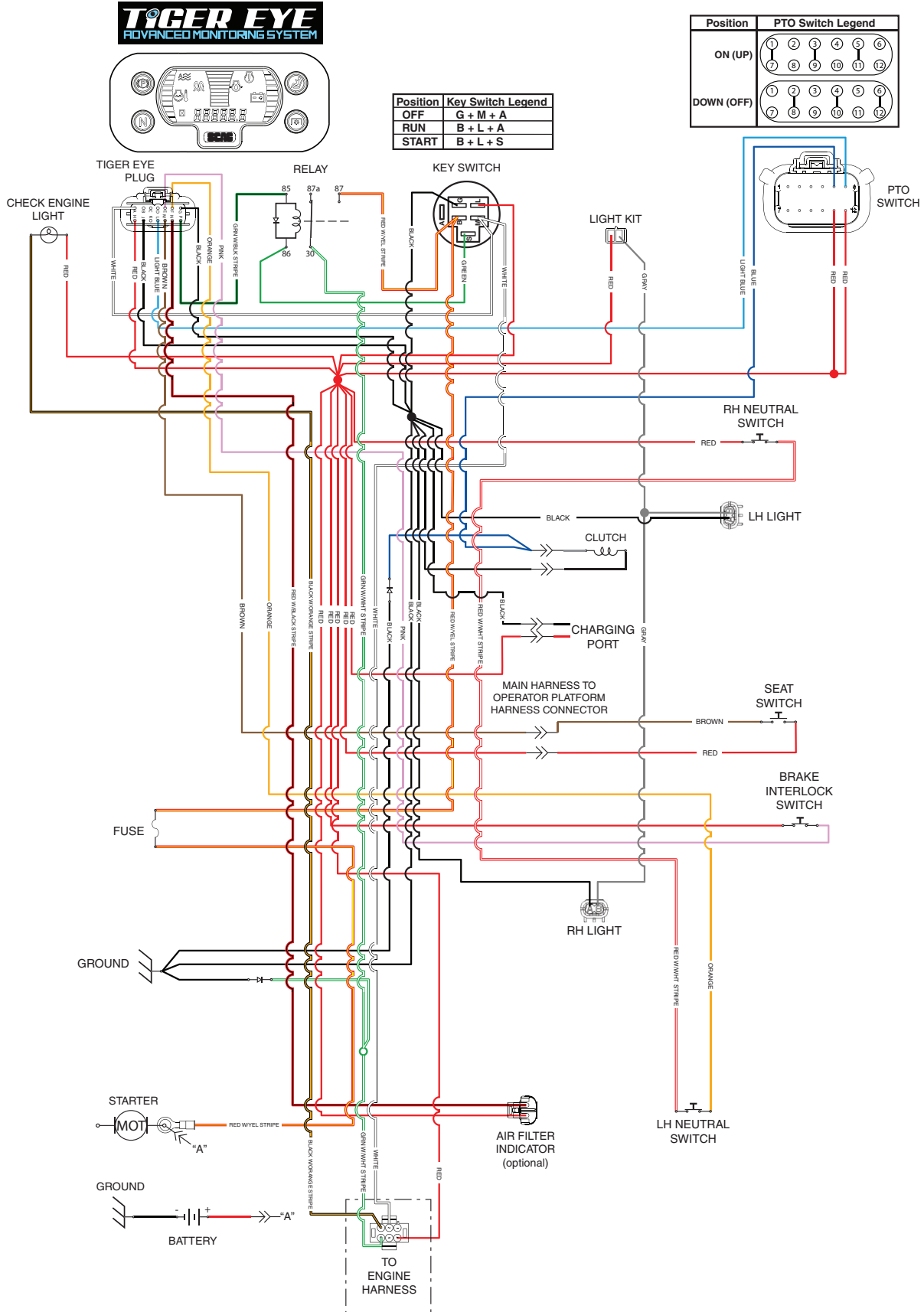

BRIGGS & STRATTON - EFI ADAPTER HARNESS ELECTRICAL SCHEMATIC

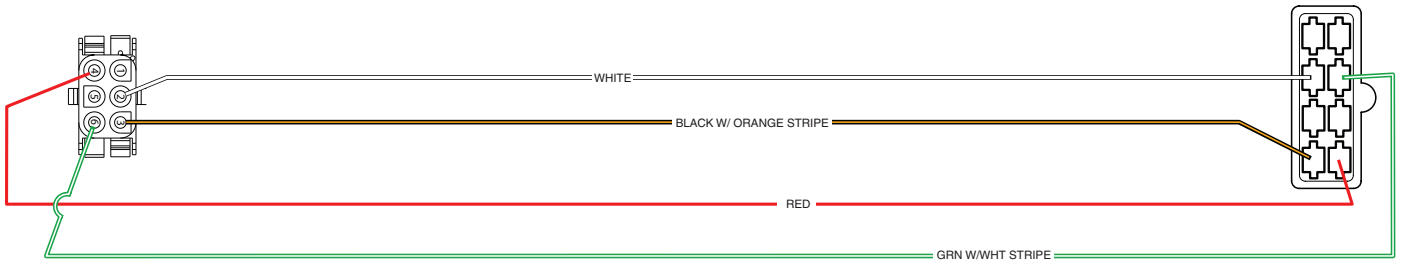

SCZII FX-EFI ELECTRICAL SCHEMATIC

(shown with Key Off, PTO Off, Park Brake Applied, Control Handles in Neutral, Seat Switch Disengaged)

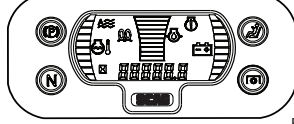

Position	Key Switch Legend
OFF	G + M + A
RUN	B + L + A
START	B + L + S

Position	PTO Switch Legend
ON (UP)	
DOWN (OFF)	

