

SCAG[®]

POWER EQUIPMENT

OPERATOR'S MANUAL



Freedom Z

**Models: SFZ48-22KT
SFZ52-24KT**

Congratulations on owning a Scag mower! This manual contains the operating instructions and safety information for your Scag mower. Reading this manual can provide you with assistance in maintenance and adjustment procedures to keep your mower performing to maximum efficiency. The specific models that this book covers are listed on the inside cover. Before operating your machine, please read all the information enclosed.



WARNING

FAILURE TO FOLLOW SAFE OPERATING PRACTICES MAY RESULT IN SERIOUS INJURY OR DEATH.

- Read this manual completely as well as other manuals that came with your mower.
- DO NOT operate on steep slopes. To check a slope, attempt to back up it (with the cutter deck down). If the machine can back up the slope without the wheels slipping, reduce speed and use extreme caution.
- Under no circumstances should the machine be operated on slopes greater than 15 degrees. ALWAYS FOLLOW OSHA APPROVED OPERATION.
- Stay two cut widths away from slopes, drop offs, ditches and retaining walls.
- DO NOT mow on wet grass. Wet grass reduces traction and steering control.
- Keep all shields in place, especially the grass discharge chute.
- Before performing any maintenance or service, stop the machine and remove the spark plug wire and ignition key.
- If a mechanism becomes clogged, stop the engine before cleaning.
- Keep hands, feet and clothing away from power-driven parts.
- Keep others off the mower (only one person at a time).

REMEMBER - YOUR MOWER IS ONLY AS SAFE AS THE OPERATOR!

HAZARD CONTROL AND ACCIDENT PREVENTION ARE DEPENDENT UPON THE AWARENESS, CONCERN, PRUDENCE, AND PROPER TRAINING OF THE PERSONNEL INVOLVED IN THE OPERATION, TRANSPORT, MAINTENANCE, AND STORAGE OF THE EQUIPMENT.

This manual covers the operating instructions and illustrated parts list for:

SFZ48-22KT

with a serial number of

N2000001 to N2099999

SFZ52-24KT

with a serial number of

N2100001 to N2199999

Always use the entire serial number listed on the serial number tag when referring to this product.

Table of Contents

48 & 52 CUTTER DECKS	2
CUTTER DECK CONTROLS - SFZ48 / 52	4
SHEET METAL COMPONENTS	6
SFZ ROLL-OVER PROTECTION SYSTEM	8
DRIVE SYSTEM COMPONENTS - SFZ48 / 52.....	10
EXHAUST AND ELECTRICAL SYSTEM - SFZ48 / 52.....	12
FUEL SYSTEM - SFZ48 / 52.....	14
FREEDOM TRANSAXLE	16
REPLACEMENT DECALS AND INFORMATION PLATES	18
ELECTRICAL SCHEMATIC	20

48 & 52 CUTTER DECKS

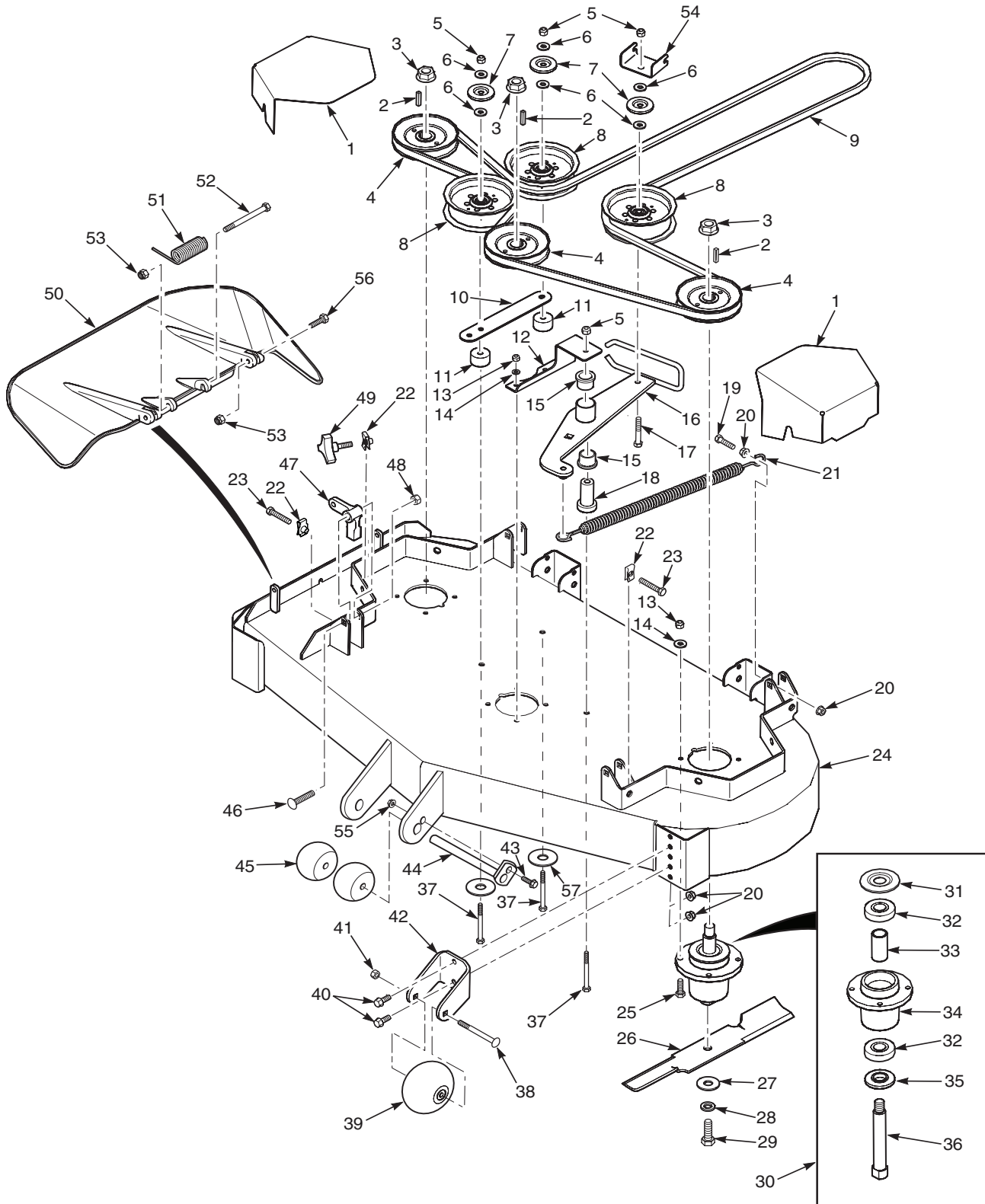

48 & 52 CUTTER DECKS

	Part No.	Description	48	52
1	424528	Belt Cover	x	x
2	04063-01	Key, 1/4 x 1/4 x 1-1/4"	x	x
3	04112-06	Nut, 3/4-16 Spiral Lock	x	x
4	483323	Pulley, 5.13" OD - 25mm Bore	x	
	483324	Pulley, 5.73" OD - 25mm Bore		x
5	04021-09	Nut, Elastic Stop 3/8-16	x	x
6	04043-04	Flatwasher, 3/8-.391 x .938 x .105	x	x
7	424367	Dust Shield	x	x
8	483422	Pulley, 5" Idler	x	x
9	483325	Belt, Cutter Deck	x	
	483326	Belt, Cutter Deck		x
10	424479	Brace, Pulley	x	x
11	43711	Spacer	x	x
12	424548	Support, Idler Pivot	x	
	424547	Support, Idler Pivot		x
13	04021-22	Nut, Elastic Stop	x	x
14	04030-03	Lockwasher, 5/16 Spring	x	x
15	483453-03	Bearing	x	x
16	462037	Idler Arm (incl. item #15)	x	x
17	04001-31	Bolt, Hex Head 3/8-16 x 2-1/2"	x	x
18	43708	Pivot, Idler	x	x
19	04001-136	Bolt, Hex Head 3/8-16 x 1-1/2 Gr.8	x	x
20	04019-04	Nut, Serrated Flange 3/8-16	x	x
21	483375	Spring, Idler	x	x
22	04110-03	U-Nut, 3/8-16	x	x
23	04107-04	Bolt, Hex Head 3/8-16 x 2" Special Lock	x	x
24	462039	Cutter Deck w/Decals, SFZ48	x	
	462040	Cutter Deck w/Decals, SFZ52		x
25	4001-11	Bolt, Hex Head 5/16-18 x 1-1/2"	x	x
26	482877	Cutter Blade, 16-1/2"	x	
	482878	Cutter Blade, 18"		x

	Part No.	Description	48	52
27	04043-06	Flatwasher, 5/8-.688 x 1.75 x .134 HD		x
			x	x
28	04030-07	Lockwasher, 1/2 Spring	x	x
29	04001-121	Bolt, Hex Head 5/8-11 x 1-1/2"	x	x
30	461950	Spindle Assembly	x	x
31	483304	Debris Shield	x	x
32	483303	Bearing	x	x
33	43693	Spacer	x	x
34	462014	Spindle Housing Assembly (Incl. item #32, 33)	x	x
35	43694	Protector, Bearing	x	x
36	43695	Shaft, Spindle	x	x
37	04001-77	Bolt, Hex Head 3/8-16 x 3-1/2"	x	x
38	04003-26	Bolt, Carriage 3/8-16 x 4"	x	x
39	481632	Wheel, Anti-Scalp	x	x
40	04017-27	Bolt, Hex Head 3/8-16 x 1" Ser. Flg.	x	x
41	04021-05	Nut, Center Lock 3/8-16	x	x
42	422478	Bracket, Anti-Scalp	x	x
43	04001-09	Bolt, Hex Head 5/16-18 x 1"	x	x
44	451926	Shaft Weldment	x	x
45	482295	Wheel, Anti-Scalp	x	x
46	04003-42	Bolt, Carriage 7/16-14 x 2-1/4"	x	x
47	483361	Lever, Deck Level	x	x
48	04021-11	Nut, Elastic Stop 7/16-14	x	x
49	481625-01	Knob w/Stud	x	x
50	462031	Discharge Chute Assy. SFZ48	x	
	462032	Discharge Chute Assy. SFZ52		x
51	482245	Spring, Discharge Chute	x	x
52	04001-154	Bolt, Hex Head 5/16-18 x 4-3/4"	x	x
53	04021-10	Nut, Elastic Stop 5/16-18	x	x
54	424615	Bracket, Belt Guide	x	x
55	04019-03	Nut, Serrated Flange 5/16-18	x	x
56	04001-12	Bolt, Hex Head 5/16-18 x 1-3/4"	x	x
57	04041-38	Flatwasher, 3/8-.406 x 2.25 x .1875	x	x

CUTTER DECK CONTROLS - SFZ48 / 52

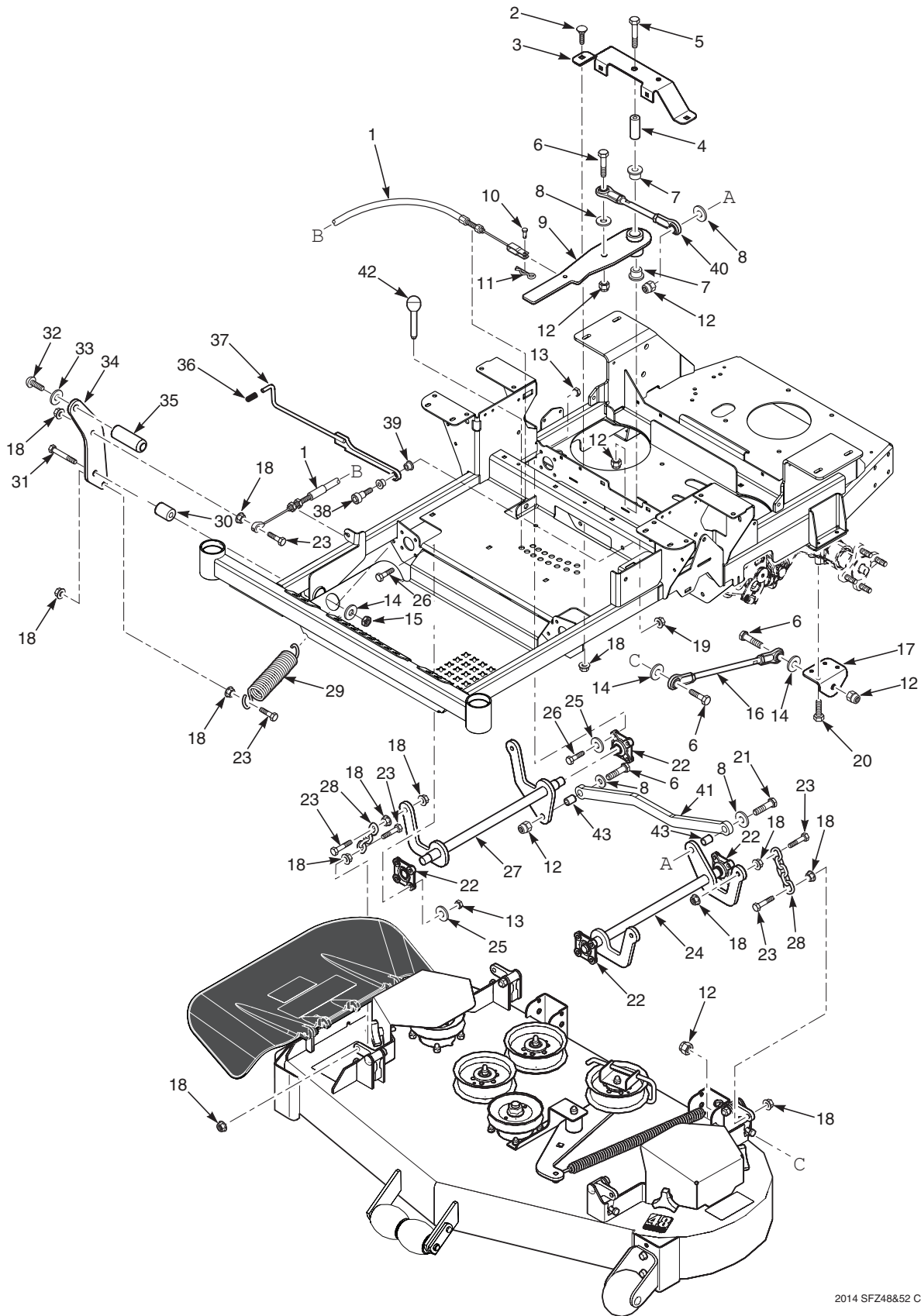

CUTTER DECK CONTROLS - SFZ48 / 52

Ref. No.	Part No.	Description
1	483341	Cable, Deck Lift
2	04003-31	Bolt, Carriage 3/8-16 x 3/4"
3	424476	Support, Idler Arm
4	43710	Spacer, Deck Lift Pivot
5	04001-90	Bolt, Hex Head 1/2-13 x 3-3/4"
6	04001-72	Bolt, Hex Head 1/2-13 x 2"
7	483453-03	Bearing
8	04040-07	Flatwasher, 1/2-.531 x 1.06 x .095
9	461999	Deck Lift Bellcrank Assembly
10	04064-17	Clevis Pin, 5/16 x 3/4"
11	04062-01	Hair Pin, .094 x 1.62"
12	04021-07	Nut, Elastic Stop 1/2-13
13	04021-10	Nut, Elastic Stop 5/16-18
14	04040-13	Flatwasher, 1/2-.562 x 1.375 x .109
15	04021-09	Nut, Center Lock 1/2-13
16	483332	Linkage, Push Arm
17	424489	Bracket, Push Arm Link
18	04019-04	Nut, Serrated Flange 3/8-16
19	04021-09	Nut, Elastic Stop 3/8-16
20	04001-49	Bolt, Hex Head 5/16-18 x 3"
21	04001-190	Bolt, Hex Head 1/2-13 x 2-3/4"
22	483334	Bearing, Deck Lift
23	04001-20	Bolt, Hex Head 3/8-16 x 1-1/2"
24	451868	Weldment, Deck Lift LH
25	04040-14	Flatwasher, 1/4-.312 x .750 x .065
26	04001-09	Bolt, Hex Head 5/16-18 x 1"
27	451867	Weldment, Deck Lift RH
28	482628	Chain, Deck lift
29	483374	Spring, Deck Lift
30	43710	Sleeve, Deck Lift Pivot
31	04001-74	Bolt, Hex Head 1/2-13 x 3"
32	04105-01	Bolt, Head Socket 5/8-11 x 1-1/2"
33	04030-07	Lockwasher, 5/8 Spring
34	424535	Pedal, Foot Bracket
35	424504	Foot Pedal
36	483492	Grip, Deck Latch
37	491254	Weldment, Deck Latch
38	04009-06	Bolt, Shoulder 1/2 x 1/2
39	483453-10	Bearing
40	483328	Linkage Assembly, Deck Lift
41	426579	Link, Deck Lift
42	483498	Pin, Height Adjuster
43	43957	Sleeve

SHEET METAL COMPONENTS

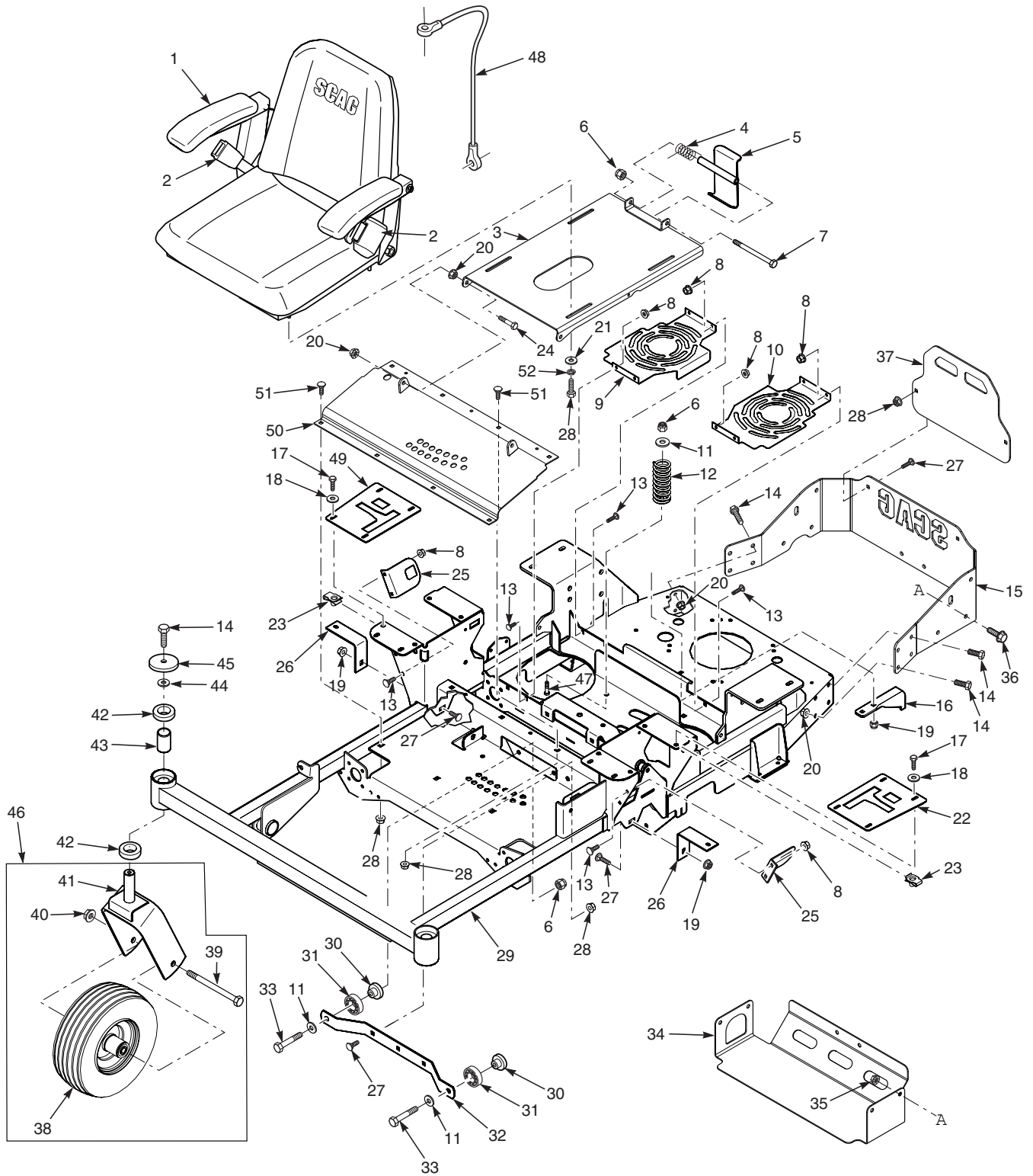

SHEET METAL COMPONENTS

	Part No.	Description
1	485211	Seat Assembly
	485162	Back Cushion
	485163	Bottom Cushion
	483549	Arm Rest Kit
	485239	Seat Pan
2	485164	Seat Belt Assembly, Retractable
	461990	Hardware Package, Mounting
3	462707	Seat Base w/Decal
4	483371	Spring, Seat Latch
5	451883	Seat Latch
6	04021-09	Nut, Elastic Stop 3/8-16
7	04001-100	Bolt, Hex Head 3/8-16 x 6"
8	04019-02	Nut, Serrated Flange 1/4-20
9	425698	Cover, Fan RH
10	425697	Cover, Fan LH
11	04041-07	Flatwasher, 3/8-.391 x .938 x .105
12	483372	Spring, Seat
13	04003-07	Bolt, Carriage 1/4-20 x 1"
14	04001-19	Bolt, Hex Head 3/8-16 x 1"
15	426043	Rear Bumper
16	424523	Bracket, Anti-Rotation
17	04001-14	Bolt, Hex Head 1/4-20 x 1"
18	04040-14	Flatwasher, 1/4-.312 x .750 x .065
19	04021-10	Nut, Elastic Stop 5/16-18
20	04019-04	Nut, Serrated Flange 3/8-16
21	04040-15	Flatwasher, 5/16-.375 x .875 x .083
22	462023	Control Plate LH
23	04110-01	U-Nut 1/4-20
24	04001-20	Bolt, Hex Head 3/8-16 x 1-1/2"
25	424511	Bracket, Switch Mount
26	424516	Bracket, Tank Mount

Ref. No.	Part No.	Description
27	04003-12	Bolt, Carriage 5/16-18 x 3/4"
28	04001-08	Bolt, Hex Head 5/16-18 x 3/4"
29	462708	Main Frame w/Decals
30	43703	Spacer, Bearing
31	483379	Bearing
32	424480	Support, Deck Guide
33	04001-21	Bolt, Hex Head 3/8-16 x 1-3/4"
34	426044	Heatshield
35	04019-04	Nut, Serrated Flange 3/8-16
36	04017-26	Bolt, Hex Head Serrated Flange 3/8-16 x 3/4"
37	426053	Engine Guard
38	485939	Caster Wheel Assembly
39	04001-134	Bolt, Hex Head 1/2-13 x 7-1/2"
40	04021-07	Nut, Elastic Stop 1/2-13
41	452897	Yoke, Caster Wheel
42	483466	Bearing
	424636	Spacer, Yoke (not shown)
43	43736	Spacer, Caster Bearing
44	04040-11	Flatwasher, 7/16-.50 x 1.250 x .083
45	04041-38	Flatwasher, 3/8-.406 x 2.25 x .188
46	462993	Caster Wheel Assembly w/Yoke
47	04003-11	Bolt, Carriage 3/8-16 x 1-1/4"
48	483559	Cable, Seat Stop
49	462024	Control Plate RH
50	462760	Weldment, Deck Lift Cover w/Decal
51	04003-14	Bolt, Carriage 5/16-18 x 1/2"
52	04030-03	Lockwasher, 5/16" Spring

SFZ ROLL-OVER PROTECTION SYSTEM

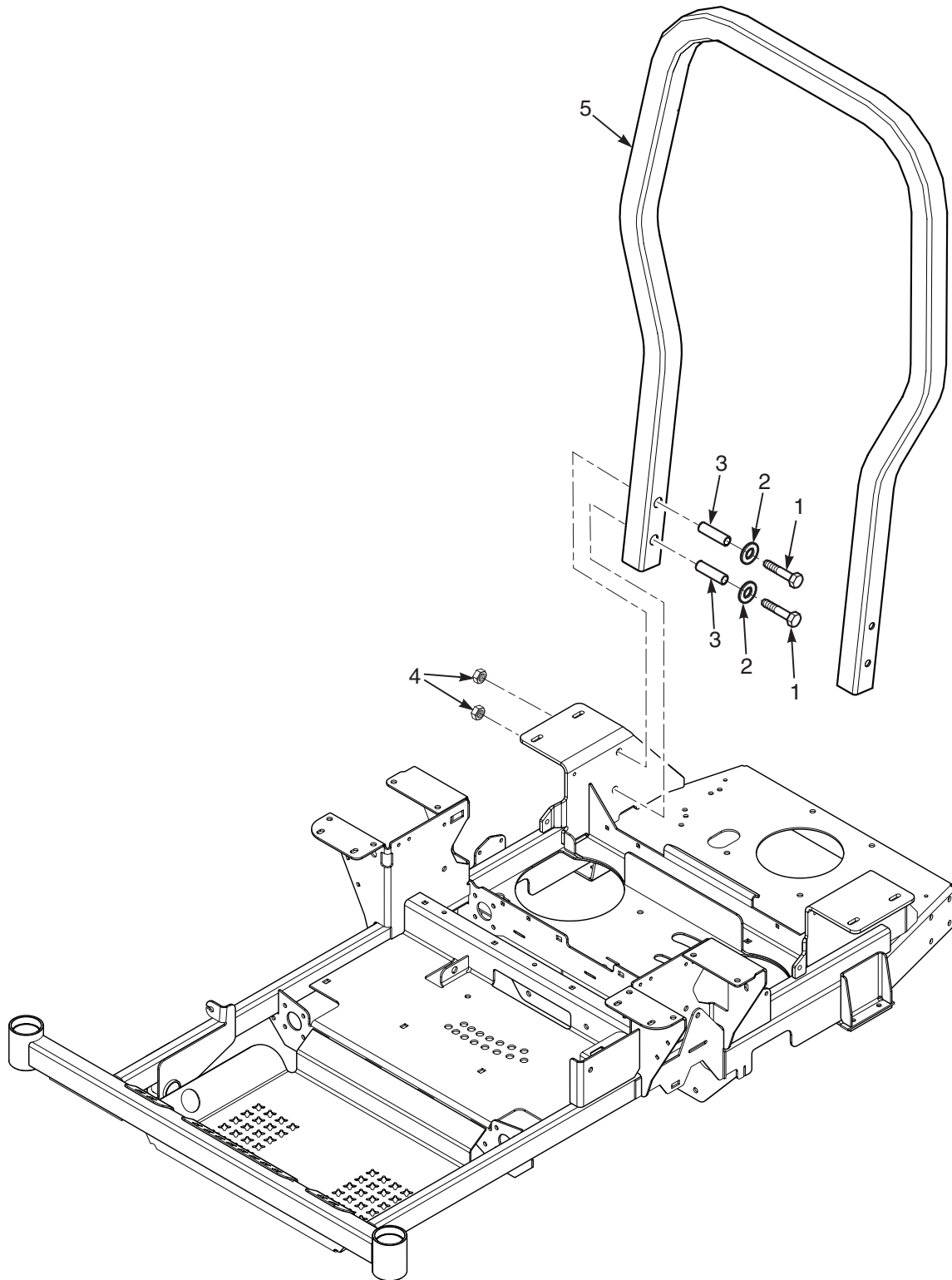

SFZ ROLL-OVER PROTECTION SYSTEM

Ref. No.	Part No.	Description
1	04001-184	Bolt, Hex Head 1/213 x 3-1/4" Gr. 8
2	04040-07	Flatwasher, 1/2 - .531 x 1.062 x .095
3	43743	Bushing, SFZ ROPS
4	04117-04	Nut, Flanged Elastic Stop, 1/2-13
5	462021	ROPS, SFZ48, SFZ52

DRIVE SYSTEM COMPONENTS - SFZ48 / 52

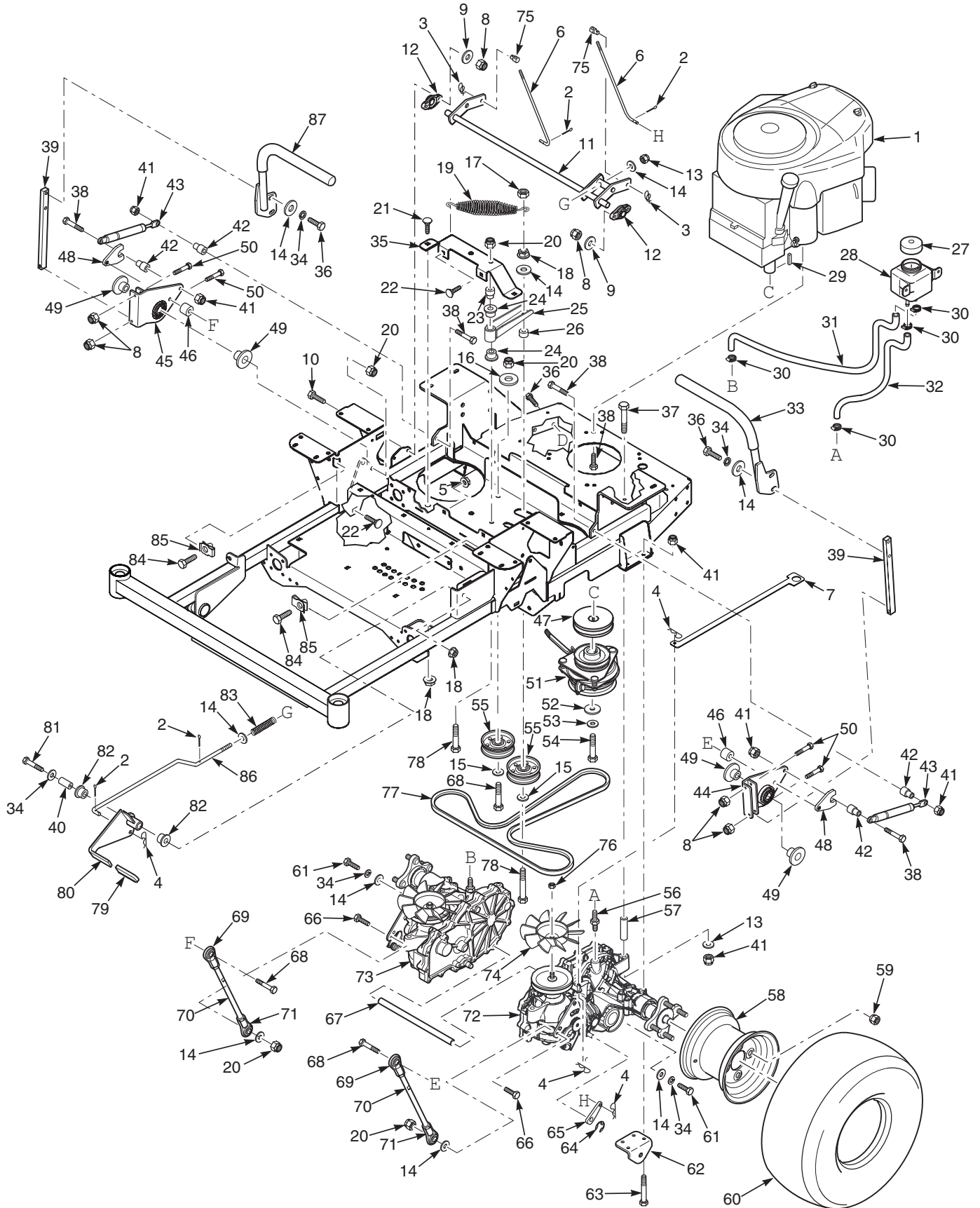

DRIVE SYSTEM COMPONENTS - SFZ48 / 52

Ref. No.	Part No.	Description
1	**485971	Engine, Kohler 22KT
	**485972	Engine, Kohler 24KT
2	04061-01	Cotter Pin, 3/32 x 1"
3	04069-01	Pin, Rue Cotter 3/8" Dia.
4	04062-02	Hair Pin, .080 x 1.19"
5	04019-03	Nut, Serrated Flange 5/16-18
6	44165	Rod, Brake Adjustment
7	426591	Lever, Dump Valve
8	04021-08	Nut, Elastic Stop 1/4-20
9	04040-14	Flatwasher, 1/4-.312 x .750 x .065
10	04017-07	Bolt, Serrated Flange 1/4-20 x 1-1/4"
11	451884	Weldment, Brake Lever
12	483504	Bearing
13	04040-15	Flatwasher, 5/16-.375 x .875 x .083
14	04041-07	Flatwasher, 3/8-.391 x .938 x .105
15	04043-04	Flatwasher, 3/8-.391 x .938 x .105 HD
16	04041-11	Flatwasher, 3/8-.406 x 1.5 x 7 GA.
17	04021-05	Nut, Center Lock 3/8-16
18	04019-04	Nut, Serrated Flange 3/8-16
19	483087	Spring, Transmission Idler
20	04021-09	Nut, Elastic Stop 3/8-16
21	04003-31	Bolt, Carriage 3/8-16 x 3/4"
22	04003-12	Bolt, Carriage 5/16-18 x 3/4"
23	43715	Shaft Pivot, Idler Arm
24	483453-04	Bearing
25	462122	Transmission Idler Arm Assembly
26	43720	Spacer, Idler Pulley
27	483514	Cap
28	483438	Reservoir Assembly
29	04063-19	Key, 1/4 x 1/4 x 3/4"
30	48136-05	Clamp, 0.87" Max Dia.
31	483431	Hose, RH Transmission
32	483432	Hose, LH Transmission
33	462433	Handle Bar Assembly LH, w/Grip
	484376	Grip
34	04041-07	Flatwasher, 3/8-.391 x .938 x .105
35	424476	Support, Idler Arm
36	04001-19	Bolt, Hex Head 3/8-16 x 1"
37	04001-95	Bolt, Hex Head 5/16-18 x 5"
38	04001-11	Bolt, Hex Head 5/16-18 x 1-1/2"
39	424498	Bar, Control Lever
40	43969	Pivot, Brake Lever
41	04021-10	Nut, Elastic Stop 5/16-18
42	43602	Spacer, Pump Dampener
43	484193	Dampener
44	462127	Control Link, LH
45	462128	Control Link, RH
46	43674	Spacer
47	483320	Pulley, 4-1/2" Dia. 1" Bore
48	424687	Nut, Control Linkage

Ref. No.	Part No.	Description
49	43719	Spacer, Linkage
50	04001-04	Bolt, Hex Head 1/4-20 x 1-1/2"
51	462715	Electric Clutch Assembly
	04063-19	Key, 1/4 x 1/4 x 3/4" (not shown)
52	04041-28	Flatwasher, 7/16-.469 x 1.75 x .25
53	04030-05	Lockwasher, 7/16" spring
54	04102-03	Bolt, Hex Head 7/16-20 x 2-1/4" Patch
55	483638	Pulley, 3-1/2" Dia.
56	482800-04	Fitting, Transmission
57	43700	Spacer, Axle
58	485949	Rim w/Valve Stem
59	04028-02	Wheel Nut, 1/2-20
60	485948	Wheel Assembly
	485950	Tire, 20 x 10-8 2-Ply
61	04001-46	Bolt, Hex Head 3/8-16 x 2-1/4"
62	424489	Bracket, Pusharm Link
63	04001-49	Bolt, Hex Head 5/16-18 x 3"
64	HG53019	Clip, Brake Lever (order through Hydro-Gear)
65	HG52639	Lever, Brake (order through Hydro-Gear)
66	04001-32	Bolt, Hex Head 3/8-16 x 1-1/4"
67	43701	Spacer, Axle
68	04001-45	Bolt, Hex Head 3/8-16 x 2"
69	483340	Rod End, 3/8-24 LH
70	483337	Linkage, Pump (incl. #69, 71)
71	483339	Rod End, 3/8-24 RH
72	485208	Transaxle Assy., LH (ZK-KCBC-3LKG-3NXX)
73	485209	Transaxle Assy., RH (ZK-GCBC-3LKF-2NXX)
74	HG53823	Fan (order through Hydro-Gear)
75	43726	Joint, Swivel
76	HG44133	Fan Nut (order through Hydro-Gear)
77	483314	Belt, Transmission Drive
78	04001-54	Bolt, Hex Head 3/8-16 x 3"
79	482102	Grip, Brake Handle
80	462010	Brake Handle Assembly
81	04001-31	Bolt, Hex Head 3/8-16 x 2-1/2"
82	483453-05	Bearing
83	483538	Spring, Brake
84	04107-01	Bolt, Hex Head 3/8-16 x 1-1/4" Special Lock
85	04110-03	U-Nut, 3/8-16
86	44157	Rod, Brake Linkage
87	462434	Handle Bar Assembly RH, w/Grip
	484376	Grip

** Available through engine manufacturer.

EXHAUST AND ELECTRICAL SYSTEM - SFZ48 / 52

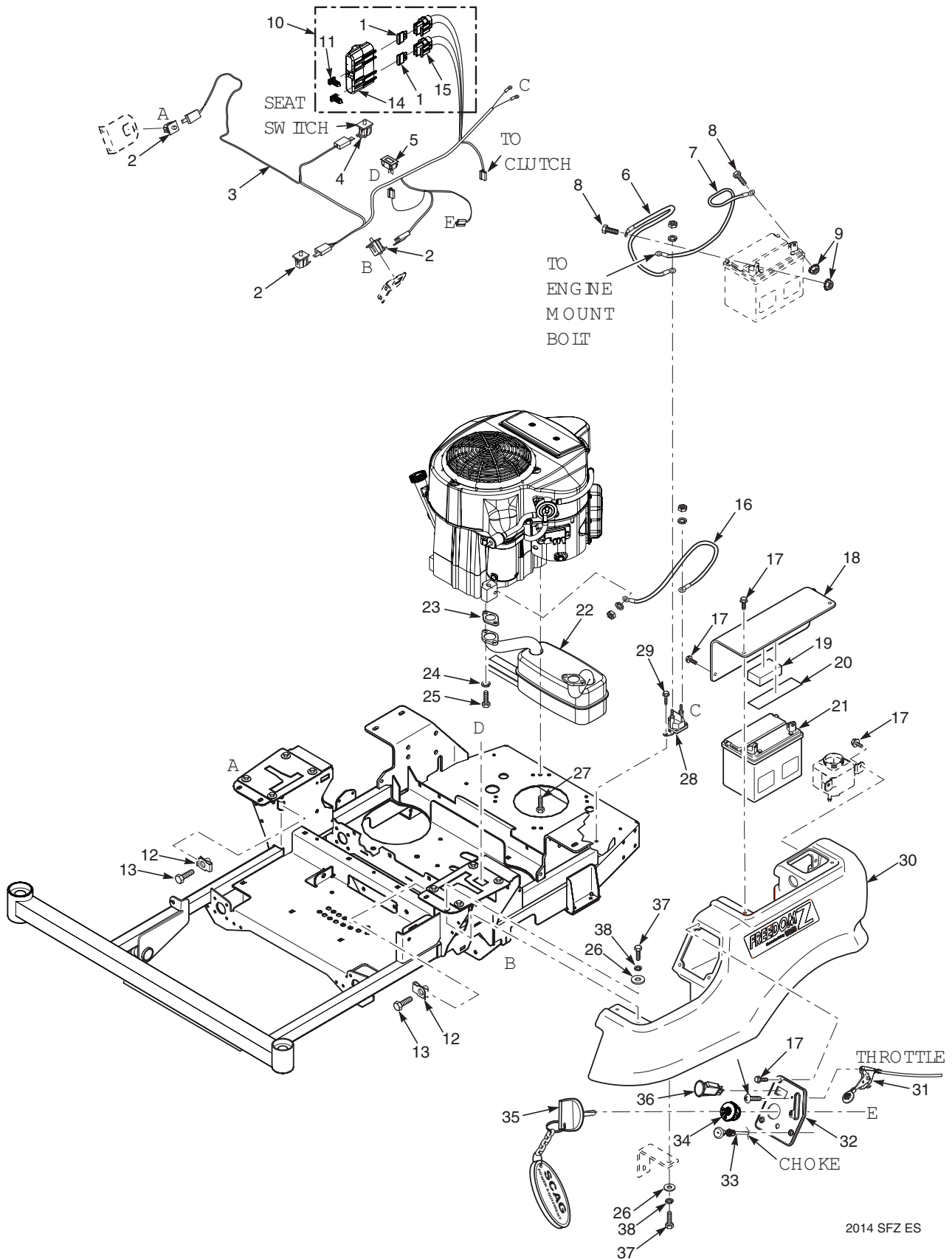

EXHAUST AND ELECTRICAL SYSTEM - SFZ48 / 52

Ref. No.	Part No.	Description
1	48298	Fuse, 20 amp
2	483473	Switch
3	484433	Wire Harness, Main
4	483473	Switch, Seat
5	485216	Hourmeter
6	48029-13	Battery Cable, Red 25"
7	48029-11	Battery Cable, Black 27"
8	04001-44	Bolt, Hex Head 1/4-20 x 1/2"
9	04020-02	Nut, 1/4-20
10	483642	Double Fuse Assy. (incl. items 1, 14, 15, 46)
11	482588	Clip, Wire
12	04110-03	U-Nut, 3/8-16
13	04107-03	Bolt, Hex Head 3/8-16 x 1-1/4" Special Lock
14	483571	Cover, Sealed Double
15	483629	Fuse Holder
16	48029-09	Battery Cable, Red 9"
17	04017-04	Bolt, Hex Head 1/4-20 x 1/2" Serr. Flange
18	461996	Battery Cover (incl. items 19 & 20)
19	483452	Pad, Battery Hold Down
20	483508	Rubber Pad
21	*483665	Battery (not avail. through Scag)
22	485336	Muffler, Kohler KT
23	**	Exhaust Gasket
24	04040-15	Lockwasher
25	04001-32	Bolt
26	04030-04	Flatwasher, 5/16-.375 x .875 x .083
27	04011-07	Bolt, Hex Head 3/8-16 x 1-1/4"

Ref. No.	Part No.	Description
28	483278	Solenoid
29	04011-14	Bolt, Self Tapping 1/2-20 x 3/4" Shakeproof
30	462751	Tank, LH
31	483645	Throttle Cable - Kohler
32	462322	Instrument Panel w/Decal
33	483646	Choke Cable - Kohler
34	483472	Ignition Switch
35	462069	Key Assembly w/Fob
36	483957	PTO Switch
37	04001-08	Bolt, Hex Head 5/16-18 x 3/4"
38	04030-03	Lockwasher, 5/16" Spring

* Not available through Scag Power Equipment. Purchase locally.

** Available through individual engine manufacturer.

FUEL SYSTEM - SFZ48 / 52

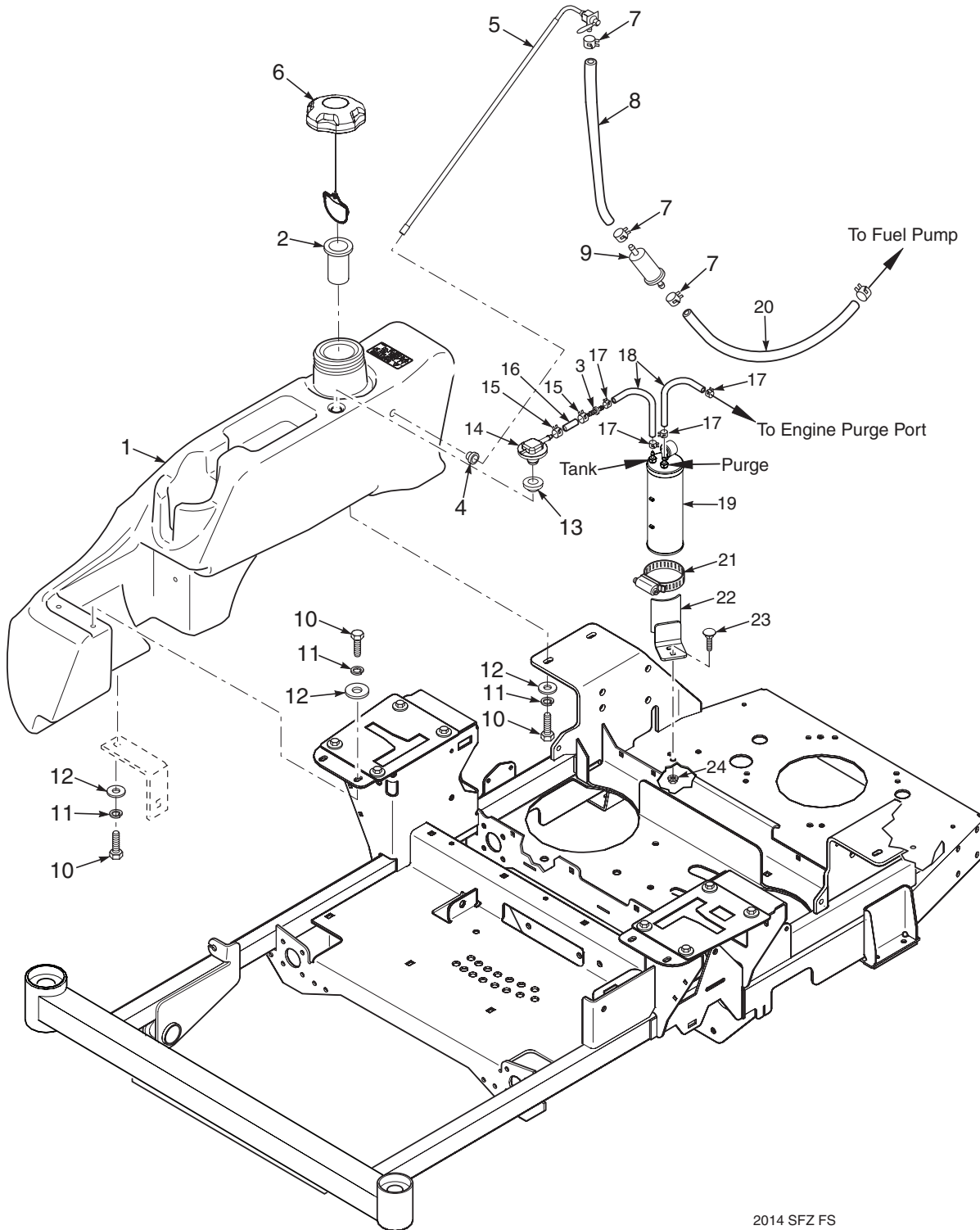

2014 SFZ FS

FUEL SYSTEM - SFZ48 / 52

Ref. No.	Part No.	Description
1	462751	Fuel Tank Assembly, LP - SFZ - LC
2	484279-01	Tube, Fuel Tank Insert
3	484343-01	Mender, 1/4 x 3/16 w/0.02 Hole
4	482571	Bushing, .56 Dia. Viton
5	483555	Fuel Tube Assembly
6	484286	Fuel Cap, Tethered
	484297	Fuel Cap w/Tethered - California Models Only (not shown)
7	48059-01	Clamp, Fuel Hose 1/4"
8	483617	Fuel Hose, 1/4" Non-Perm (order by inch)
9	*	Fuel Filter
10	04001-08	Bolt, Hex Head 5/16-18 x 3/4"
11	04030-03	Lockwasher, 5/16" Spring
12	04040-15	Flatwasher, 5/16-.375 x .875 x .083
13	484285	Grommet, Viton
14	484333	Remote Vent
15	48059-02	Clamp, Fuel Hose 7/32"
16	484347	Hose, 1/4" Vapor Recovery (order by inch)
17	48059-05	Clamp, Vapor Recovery Hose
18	484345	Hose, 3/16" (order by inch)
19	484342	Carbon Canister
	484366	Dust Filter, Carbon Canister
20	*	Fuel Hose
21	48136-17	Clamp, Hose
22	452233	Bracket Weldment, Kohler Models
23	04003-12	Bolt, Carriage 5/16-18 x 3/4"
24	04019-03	Nut, Serrated Flange 5/16-18

* = Available through engine manufacturer only.

FREEDOM TRANSAXLE

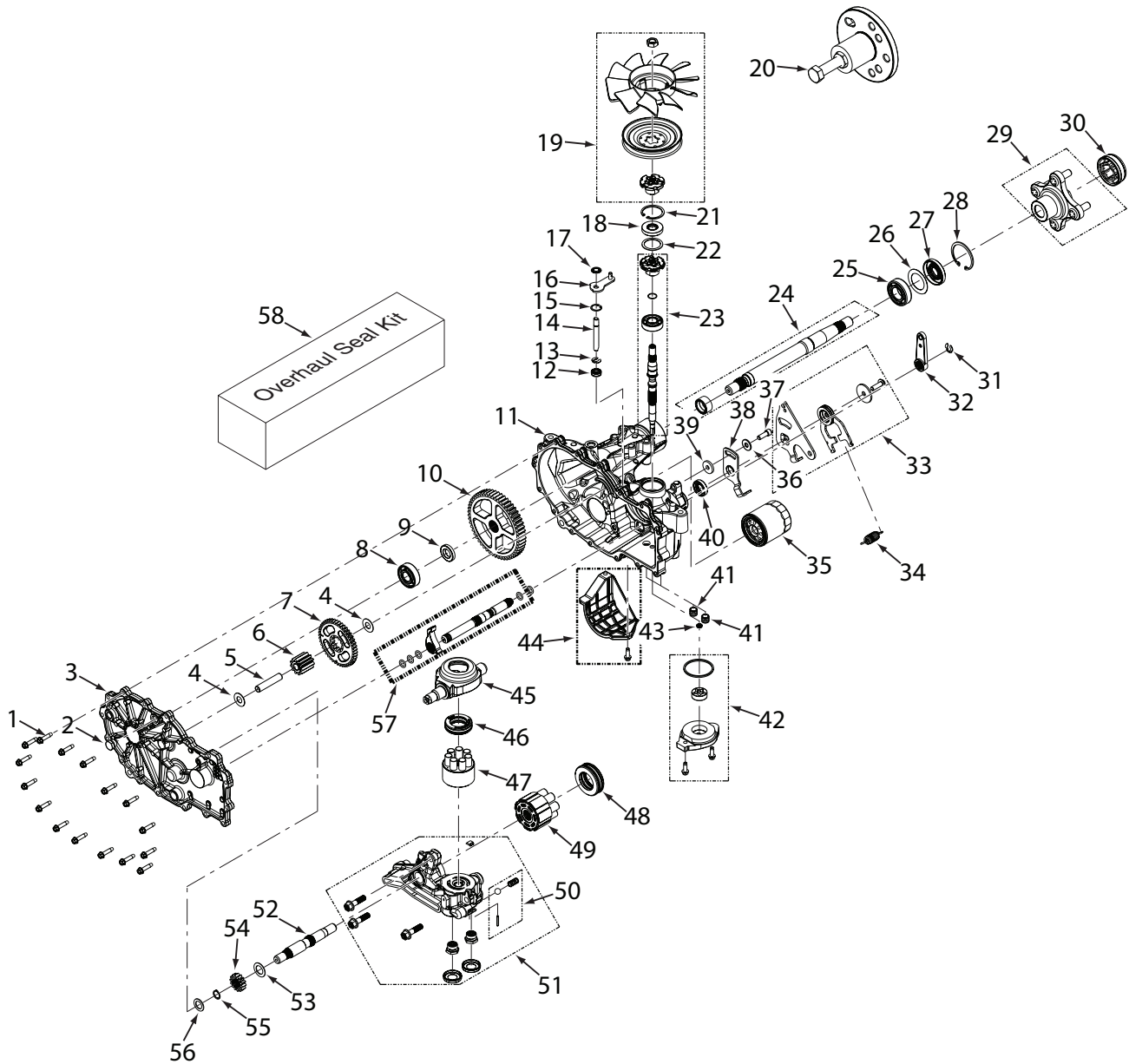

FREEDOM TRANSAXLE

Ref. No.	Part No.	Description
1	HG53246	Screw, Hex Washer
2	HG54730	Plug, External Hex Vent 9/16-18
3	HG71574	Kit, Side Cover LH
	HG71572	Kit, Side Cover RH
4	HG50132	Washer, Flat, .51 x 1 x .03
5	HG51083	Pin, Jackshaft
6	HG52583	Gear, 11T
7	HG52110	Gear, 45T
8	HG72749	Kit, Bearing
9	HG53336	Spacer, .75 x 1.320 x .257
10	HG52108	Gear, 54T
11	HG71421	Kit, Main Housing LH, Charge, Control
	HG71413	Kit, Main Housing RH Charge, Control
12	HG55232	Seal, Lip, .375 x .75 x .25
13	HG51628	Ring, Retaining External .375
14	HG52136	Rod, Bypass .375 x 2.88
15	HG51627	Ring, Retaining, .750, Internal
16	HG52370	Arm, Bypass (LH)
	HG51910	Arm, Bypass (RH)
17	HG51630	Ring, Retaining, .375 External
18	HG51161	Seal, Lip, 17 x 40 x 7
19	HG72973	Kit, Fan/Pulley
20	HG72320	Kit, Hub Puller
21	HG50329	Ring, Retaining Internal
22	HG50951	Washer, Flat, 1.23 x 1.57 x .04
23	HG73047	Kit, Input Shaft
24	HG71569	Kit, Shaft Axle
25	HG53656	Bearing 25.4 x 52 x 15 Ball (6205R)
26	HG53514	Washer, Flat, 1.355 x 2.035 x .021
27	HG53699	Seal, Lip, TC4, 1 x 2.06 x .38
28	HG50859	Ring, Retaining 2.25 Internal
29	HG71405	Kit, Hub, 4 Bolt
30	HG53088	Cap, Axle
31	HG53019	Ring, Retaining External .438
32	HG53973	Handle, Actuating
33	HG71598	Kit, RTN Bidirectional (LH)
	HG71595	Kit, RTN Bidirectional (RH)
34	HG51605	Spring, Extension
35	HG52114	Filter, Spin-on 2.6 x 3
36	HG44130	Washer, Flat, .34 x .88 x .06
37	HG51616	Bolt, 5/16-24 x 7/8" (w/patch)
38	HG51946	Arm, Return Left
	HG51945	Arm, Neutral Right
39	HG54315	Spacer, .32 ID x 1.005 OD x .1495 Thk
40	HG51140	Seal, Lip, 18 x 32 x 7
41	HG54501	Tube, Charge Triple O-ring

Ref. No.	Part No.	Description
42	HG72274	Kit, Charge
43	HG72291	Kit, Gerotor Seal
44	HG71854	Kit, Filter Guard (LH)
	HG73041	Kit, Filter Guard (RH)
45	HG51048	Swashplate, Trunnion
46	HG50551	Bearing, Thrust 30 x 52 x 13
47	HG70723	Kit,Block 7 Piston
48	HG51462	Bearing, Thrust 35 x 62 x 18
49	HG72882	Kit, 16cc Cylinder Block Assembly (steam treated)
50	HG71436	Kit, Charge Relief
51	HG72515	Kit, Center Section, LH Charge
	HG72516	Kit, Center Section, RH Charge
52	HG52150	Shaft, Motor
53	HG51069	Washer, Flat, .71 x 1.16 x .04
54	HG52109	Gear, 14T
55	HG44145	Retaining Ring, Motor Shaft
56	HG44371	Washer, Flat, .63 x 1 x .05
57	HG71569	Kit, Outboard, RH Rot B / LH Rot A (LH)
	HG72753	Kit, Outboard, RH Rot A / LH Rot B (RH)
58	HG72994	Kit, Seal (ZT-2800)
*	HG50928	Tube, Sealant



* Item not shown

REPLACEMENT DECALS AND INFORMATION PLATES

WARNING
 **INSTALL BELT COVER BEFORE OPERATING MACHINE**
 READ OPERATOR'S MANUAL 483402 1

WARNING
 DO NOT OPERATE WITHOUT DISCHARGE CHUTE, MULCHING KIT, OR ENTIRE GRASS CATCHER INSTALLED 483405 2

IMPORTANT
 Operation on slopes can be hazardous. This machine was originally equipped with a Rollover Protection Device with a Roll Bar and Seat Belt. See your dealer if either is missing or damaged. 483425 3

DANGER

SPINNING BLADES
 KEEP CLEAR

BLADE CONTACT & THROWN OBJECTS CAN INJURE 4

FORWARD
 **F**
REVERSE
 **R** 5

WARNING
 Replace seat only with Scag approved seat with seat mounting provisions and Scag approved seat belts. Failure to follow these directions could result in injury or death in the event of a rollover. 6

48
COMMERCIAL GRADE 7

WARNING
ROTATING BLADES AND BELTS
 * Keep hands, feet & clothing clear
 * Keep all guards in place
 * Shut off engine & disengage blade clutch before servicing
 * Use caution in directing discharge
 * Read instruction manual before operating
DO NOT OPERATE UNLESS GRASS CATCHER, MULCHING KIT OR DISCHARGE CHUTE IS INSTALLED 8

IMPORTANT ADJUSTMENT PROCEDURES
 READ OPERATOR'S MANUAL FOR MORE DETAILS
 Check tire pressure - Drive tires-8 psi -
 - Caster tires-25 psi

FREE WHEEL OPERATION
 To move machine without running engine, pull both dump valve rods up and back (located at rear of machine) and latch. Pull rods forward and latch into front slot to operate mower.

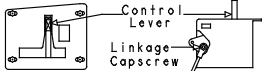
NEUTRAL ADJUSTMENT

 To re-set neutral, have engine off and control levers in neutral. Loosen upper linkage capscrew. Allow transmission to position linkage rod and tighten upper capscrew. Repeat for opposite side. If wheels still creep after adjustment, see an authorized Scag dealer.

HYDRAULIC FLUID LEVEL
 Check hydraulic fluid level while fluid is cool. Fluid level should be in sight window. Fill with 20W50 motor oil only.

IMPORTANT
 Do not overfill. Room for hot fluid expansion must be allowed or resulting expansion may cause leaks in the system.

TRACKING ADJUSTMENT

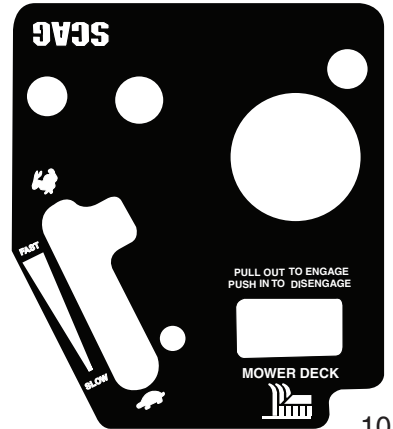
 If machine pulls to right, adjust LH control stop bolt CW (Inward) to slow left wheel down. Adjust RH control stop bolt CW (Inward) to slow right wheel down.

9

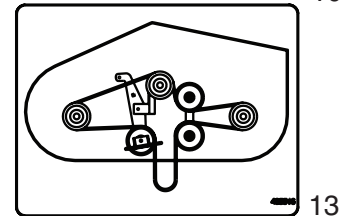

SCAG FREEDOM Z



RELEASE DECK LATCH

START/DRIVE PROCEDURE
 - Engage parking brake
 - Shift control handle to neutral position
 - Start engine
 - Release parking brake
 - Select forward or reverse with hydro control levers

USA SCAG POWER EQUIPMENT
 MAYFIELD, WEST BEND, WI
 DIVISION OF MAYFIELD

WARNING
 AVOID SERIOUS INJURY OR DEATH
 Read the Operators Manual
 - Do not operate on slopes unless you can keep the machine from rolling back down slowly.
 - If machine stops going uphill, stop blades and back down slowly.
 - Avoid sudden turns.
 - Do not mow when children or other people are around.
 - Never carry children even with blades off.
 - Look down and behind before mowing.
 - Keep safety devices (guards, shields, switches, etc.) in place and working.
 - Remove objects that could be thrown by the blades.
 - Avoid serious injury or death if you are struck by the blades.
 - Read the Operators Manual for more information.

12

REPLACEMENT DECALS AND INFORMATION PLATES

Ref. No.	Part No.	Description
1	483402	Decal, Belt Cover
2	483405	Decal, Warning
3	483425	Decal, ROPS
4	483505	Decal, Spinning Blades
5	481568	Decal, Traction Control
6	483633	Decal, Seat Replacement
7	483494	Decal, 48 Commercial
	483495	Decal, 52 Commercial
8	483406	Decal, Knives
9	483632	Decal, Adjustment SFZ
10	483499	Decal, Instrument Panel - SFZ48 & SFZ 52
11	483501	Decal, Front SFZ
12	485412	Decal, Cutting Height
*	483900	Decal, Warning Spark Arrestor (California only)
*	462155	Spanish Decal Kit - SFZ (not shown)
*	01411	DVD Video, Tips for Safe Operation of Your Scag Zero-Turn Mower (not shown)
13	485516	Decal, Belt Routing

ELECTRICAL SCHEMATIC

