

SCAG[®]

POWER EQUIPMENT

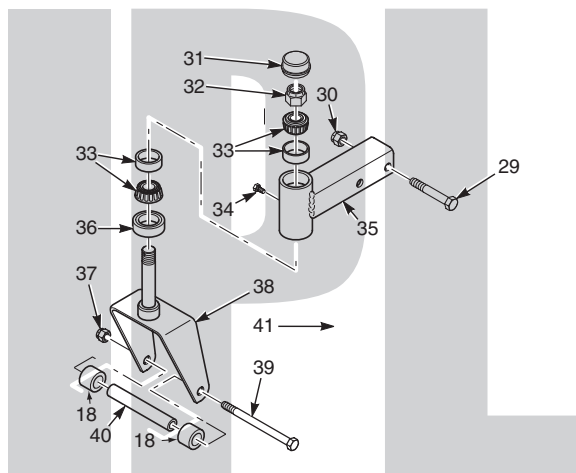

ILLUSTRATED PARTS MANUAL



Model SFZ61 Freedom Z

THIS MANUAL CONTAINS THE ILLUSTRATED PARTS LIST FOR MODELS:
SFZ61-730FS with a serial number of G6900400 to G6999999
SFZ61-30BS with a serial number of G6800400 to G6899999

Table of Contents

61" CUTTER DECK.....	2
CUTTER DECK CONTROLS - SFZ61	4
SHEET METAL COMPONENTS SFZ61	6
SEAT ASSEMBLY	8
BRAKE COMPONENTS - SFZ61.....	10
SFZ ROLL-OVER PROTECTION SYSTEM	12
DRIVE SYSTEM COMPONENTS - SFZ61.....	14
EXHAUST AND ELECTRICAL SYSTEM - SFZ61.....	16
SFZ61 FUEL SYSTEM	18
ZT-3400 HYDRAULIC AXLE ASSEMBLY -SFZ61	20
REPLACEMENT DECALS AND INFORMATION PLATES	22
ELECTRICAL SCHEMATIC	24

61" CUTTER DECK

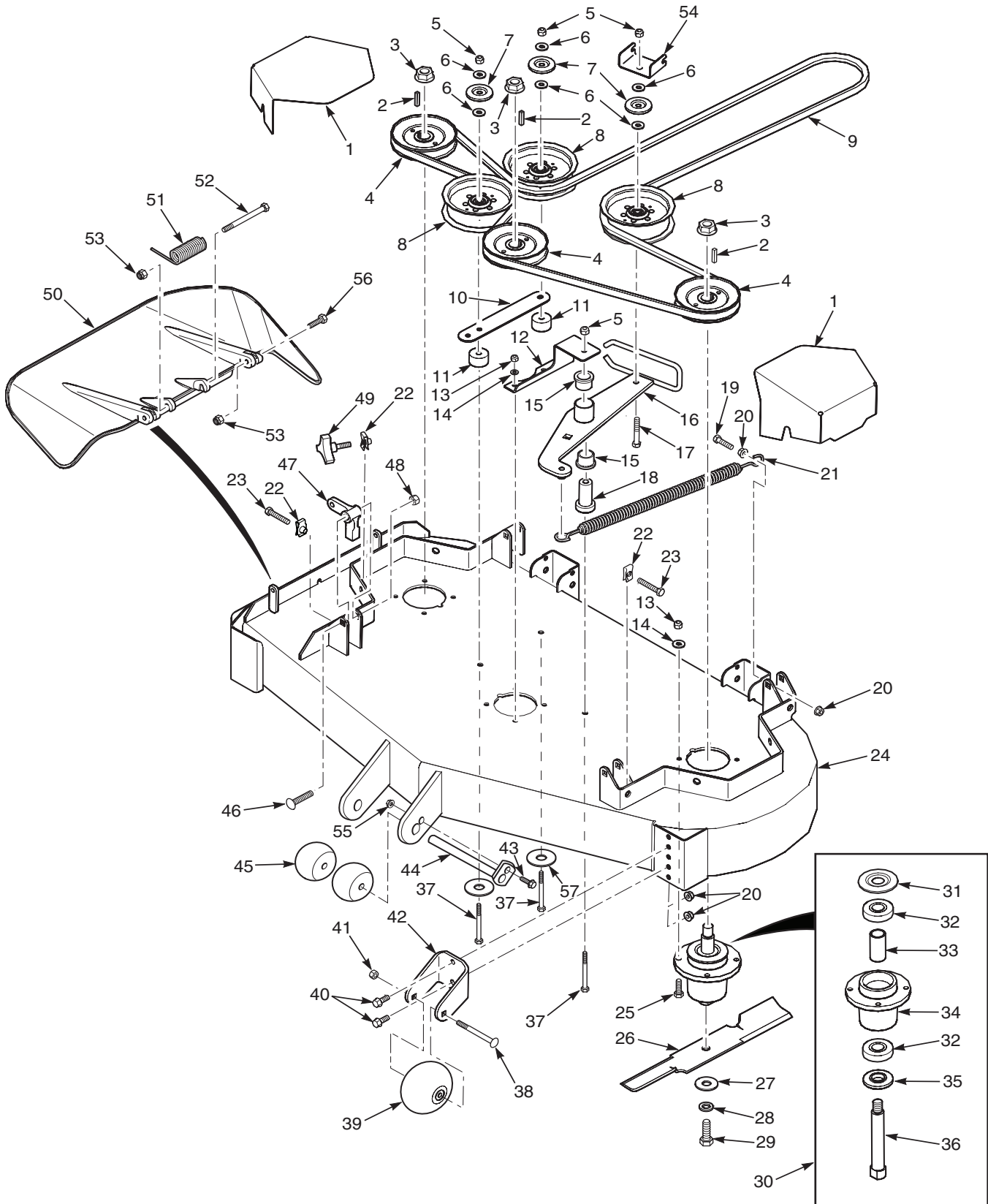

61" CUTTER DECK

	Part No.	Description
1	425260	Belt Cover
2	04063-01	Key, 1/4 x 1/4 x 1-1/4"
3	04112-06	Nut, 3/4-16 Spiral Lock
4	484026	Pulley, 6.32" OD - 25mm Bore
5	04021-09	Nut, Elastic Stop 3/8-16
6	04043-04	Flatwasher, 3/8-.391 x .938 x .105
7	424367	Dust Shield
8	483422	Pulley, 5" Idler
9	484031	Belt, Cutter Deck
10	424479	Brace, Pulley
11	43711	Spacer
12	425264	Support, Idler Pivot
13	04021-22	Nut, Elastic Stop
14	04030-03	Lockwasher, 5/16 Spring
15	483453-03	Bearing
16	462037	Idler Arm (incl. item #15)
17	04001-31	Bolt, Hex Head 3/8-16 x 2-1/2"
18	43708	Pivot, Idler
19	04001-136	Bolt, Hex Head 3/8-16 x 1-1/2 Gr.8
20	04019-04	Nut, Serrated Flange 3/8-16
21	483375	Spring, Idler
22	04110-03	U-Nut, 3/8-16
23	04107-04	Bolt, Hex Head 3/8-16 x 2" Special Lock
24	462227	Cutter Deck w/Decals, SFZ61
25	04001-11	Bolt, Hex Head 5/16-18 x 1-1/2"
26	482879	Cutter Blade, 21"
27	04043-06	Flatwasher, 5/8-.688 x 1.75 x .134 HD
28	04030-07	Lockwasher, 1/2 Spring
29	04001-121	Bolt, Hex Head 5/8-11 x 1-1/2"
30	461950	Spindle Assembly

	Part No.	Description
31	483304	Debris Shield
32	483303	Bearing
33	43693	Spacer
34	462014	Spindle Housing Assembly (Incl. item #32, 33)
35	43694	Protector, Bearing
36	43695	Shaft, Spindle
37	04001-77	Bolt, Hex Head 3/8-16 x 3-1/2"
38	04003-26	Bolt, Carriage 3/8-16 x 4"
39	481632	Wheel, Anti-Scalp
40	04017-27	Bolt, Hex Head 3/8-16 x 1" Ser. Flg.
41	04021-05	Nut, Center Lock 3/8-16
42	422478	Bracket, Anti-Scalp
43	04001-09	Bolt, Hex Head 5/16-18 x 1"
44	451926	Shaft Weldment
45	482295	Wheel, Anti-Scalp
46	04003-42	Bolt, Carriage 7/16-14 x 2-1/4"
47	483361	Lever, Deck Level
48	04021-11	Nut, Elastic Stop 7/16-14
49	481625-01	Knob w/Stud
50	462213	Discharge Chute Assembly
51	482245	Spring, Discharge Chute
52	04001-154	Bolt, Hex Head 5/16-18 x 4-3/4"
53	04021-10	Nut, Elastic Stop 5/16-18
54	424615	Bracket, Belt Guide
55	04019-03	Nut, Serrated Flange 5/16-18
56	04001-12	Bolt, Hex Head 5/16-18 x 1-3/4"
57	04041-38	Flatwasher, 3/8-.406 x 2.25 x .1875

CUTTER DECK CONTROLS - SFZ61

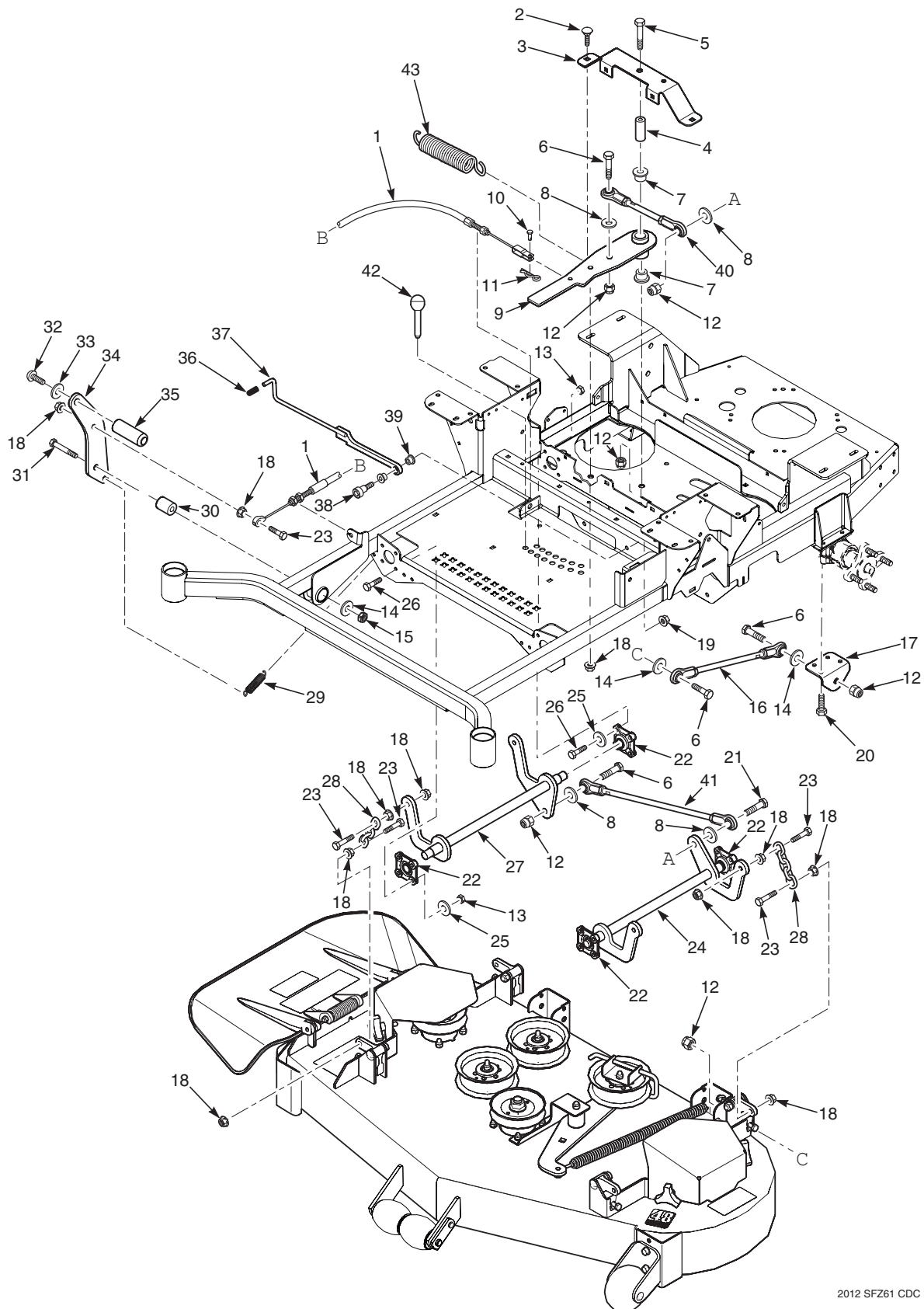

CUTTER DECK CONTROLS - SFZ61

Ref. No.	Part No.	Description
1	483341	Cable, Deck Lift
2	04003-31	Bolt, Carriage 3/8-16 x 3/4"
3	424476	Support, Idler Arm
4	43710	Spacer, Deck Lift Pivot
5	04001-90	Bolt, Hex Head 1/2-13 x 3-3/4"
6	04001-183	Bolt, Hex Head 1/2-13 x 1-3/4"
7	483453-03	Bearing
8	04040-07	Flatwasher, 1/2-.531 x 1.06 x .095
9	461999	Deck Lift Bellcrank Assembly
10	04064-17	Clevis Pin, 5/16 x 3/4"
11	04062-01	Hair Pin, .094 x 1.62"
12	04021-07	Nut, Elastic Stop 1/2-13
13	04021-10	Nut, Elastic Stop 5/16-18
14	04040-13	Flatwasher, 1/2-.562 x 1.375 x .109
15	04021-09	Nut, Center Lock 1/2-13
16	483332	Linkage, Push Arm
17	424489	Bracket, Push Arm Link
18	04019-04	Nut, Serrated Flange 3/8-16
19	04021-09	Nut, Elastic Stop 3/8-16
20	04001-49	Bolt, Hex Head 5/16-18 x 3"
21	04001-52	Bolt, Hex Head 1/2-13 x 2-1/2"
22	483334	Bearing, Deck Lift
23	04001-20	Bolt, Hex Head 3/8-16 x 1-1/2"
24	452112	Weldment, Deck Lift LH
25	04040-14	Flatwasher, 1/4-.312 x .750 x .065
26	04001-09	Bolt, Hex Head 5/16-18 x 1"
27	452113	Weldment, Deck Lift RH
28	482628	Chain, Deck lift
29	484038	Spring, Deck Lift
30	43710	Sleeve, Deck Lift Pivot
31	04001-74	Bolt, Hex Head 1/2-13 x 3"
32	04105-01	Bolt, Head Socket 5/8-11 x 1-1/2"
33	04030-07	Lockwasher, 5/8 Spring
34	424535	Pedal, Foot Bracket
35	424504	Foot Pedal
36	483492	Grip, Deck Latch
37	491254	Weldment, Deck Latch
38	04009-06	Bolt, Shoulder 1/2 x 1/2
39	483453-10	Bearing
40	483328	Linkage Assembly, Deck Lift
41	483367	Linkage Assembly, Deck Lift
42	483498	Pin, Height Adjuster
43	483374	Spring, Deck Lift

SHEET METAL COMPONENTS SFZ61

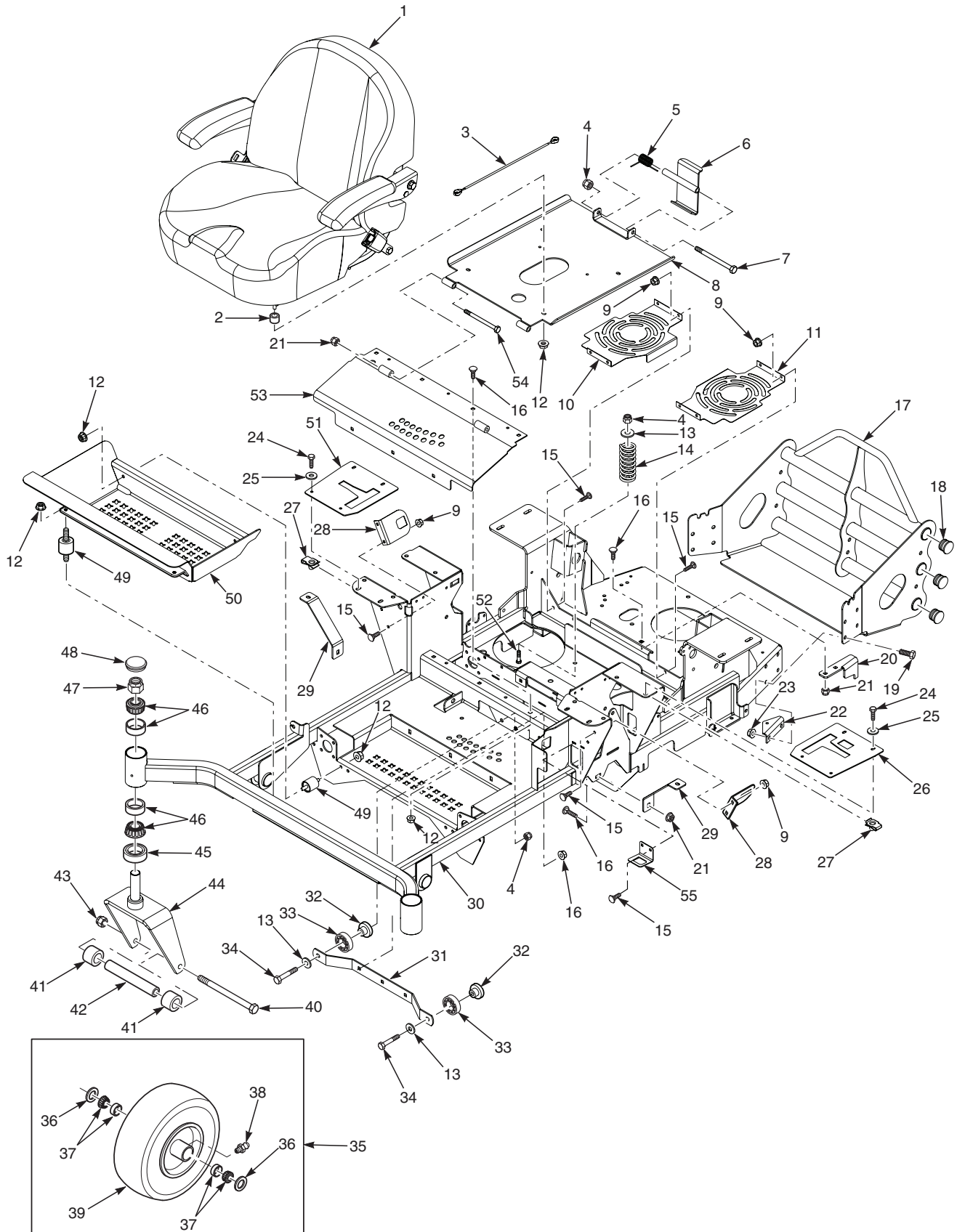

SHEET METAL COMPONENTS - SFZ61

	Part No.	Description
1	484375	Seat Assembly
2	43336	Spacer
3	483559	Cable, Seat Stop
4	04021-09	Nut, Elastic Stop 3/8-16
5	483371	Spring, Seat Latch
6	451883	Weldment, Seat Latch
7	04001-100	Bolt, Hex Head 3/8-16 x 6"
8	452264	Seat Plate Weldment, SFZ 61
9	04019-02	Nut, Serrated Flange 1/4-20
10	425698	Fan Cover, RH
11	425697	Fan Cover, LH
12	04019-03	Nut, Serrated Flange 5/16-18
13	04041-07	Flatwasher, 3/8-.391 x .938 x .105
14	483372	Spring, Seat
15	04003-07	Bolt, Carriage 1/4-20 x 1"
16	04003-12	Bolt, Carriage 5/16-18 x 3/4"
17	452334	Bumper Weldment
18	483535	Plug, Bumper Tube
19	04001-19	Bolt, Hex Head 3/8-16 x 1"
20	425696	Anti-Rotation Bracket
21	04021-10	Nut, Elastic Stop 5/16-18
22	424639	Bracket, Dump Valve
23	04019-04	Nut, Serrated Flange 3/8-16
24	04001-14	Bolt, Hex Head 1/4-20 x 1"
25	04040-14	Flatwasher, 1/4-.312 x .750 x .065
26	462483	Control Plate w/Decal, LH
27	04110-01	U-Nut, 1/4-20
28	424511	Bracket, Switch Mount
29	425700	Bracket, Tank Mount

Ref. No.	Part No.	Description
30	462443	Mainframe Assy., w/Decals
31	424480	Support, Deck Guide
32	43703	Spacer, Bearing
33	483379	Bearing
34	04001-31	Bolt, Hex Head 3/8-16 x 2-1/2"
35	482503	Wheel Assembly
36	482622	Seal
37	482621	Bearing
38	48114-04	Fitting, Grease
39	481613	Tire, 13 x 5-6
	482625	Rim
40	04001-134	Bolt, Hex Head 1/2-13 x 7-1/2"
41	43584	Spacer, Caster Wheel
42	43581	Sleeve, Caster Wheel
43	04021-07	Nut, Elastic Stop 1/2-13
44	451471	Yoke Weldment
45	481025	Seal, 2" OD x 1.625 ID
46	48668	Bearing Set
47	04021-20	Nut, Elastic Stop 1"-14
48	484195	Grease Cap
49	483493	Rubber Isolator
50	452263	Footplate Weldment, SFZ61
51	462484	Control PLate w/Decal, RH
52	04003-11	Bolt, Carriage 3/8-16 x 1-1/4"
53	462369	Deck Lift Cover w/Decal
54	04001-73	Bolt, Hex Head 5/16-18 x 3-3/4"
55	425889	Switch Bracket

SEAT ASSEMBLY

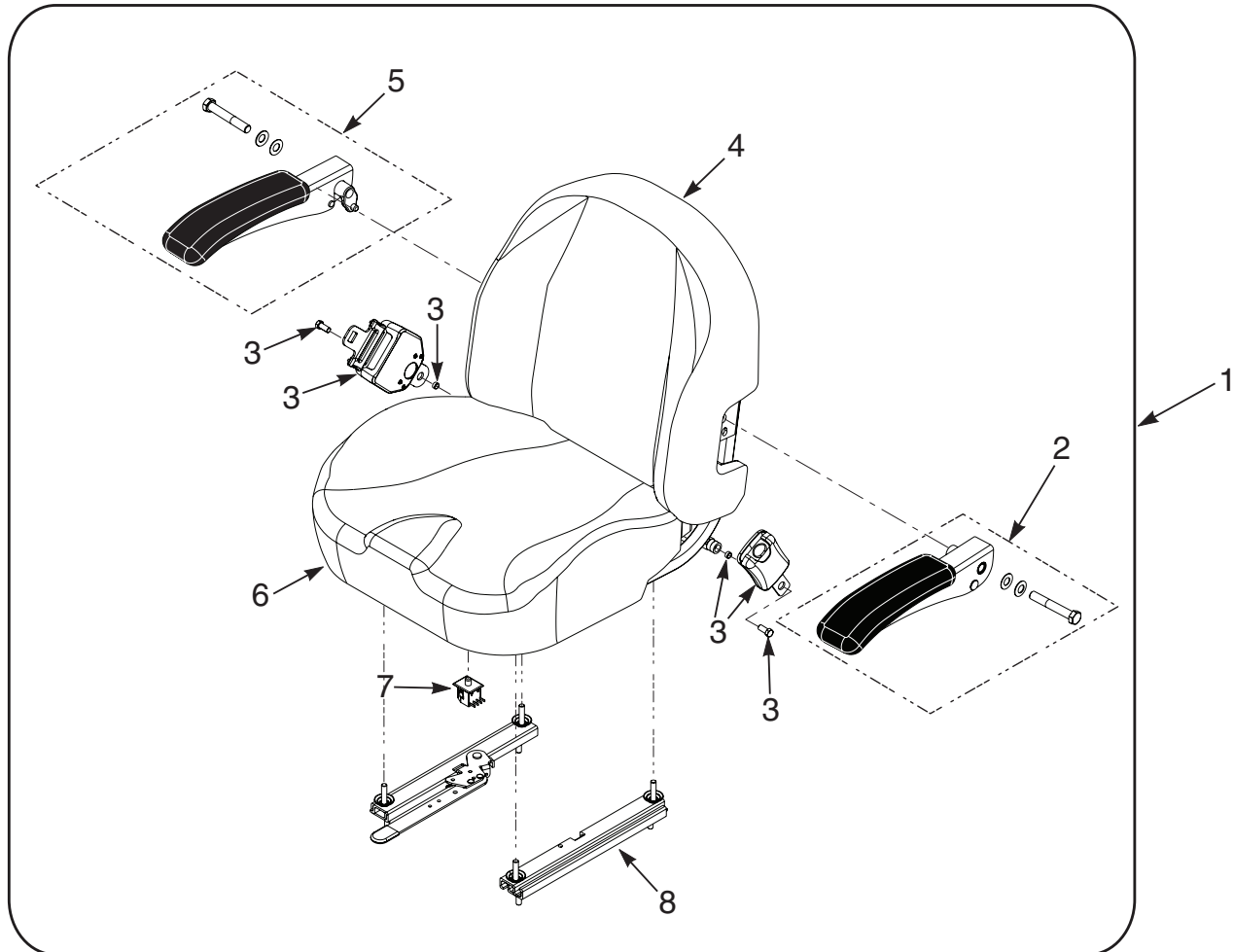

Ref. No.	Part No.	Description
1	484375	Seat Assembly
2	484260	Armrest Kit, LH
3	484527	Seatbelt Kit
4	484528	Back Cover
5	484261	Armrest Kit, RH
6	484529	Cushion Cover
7	483473	Switch
8	484526	Track Set

NOTES

BRAKE COMPONENTS - SFZ61

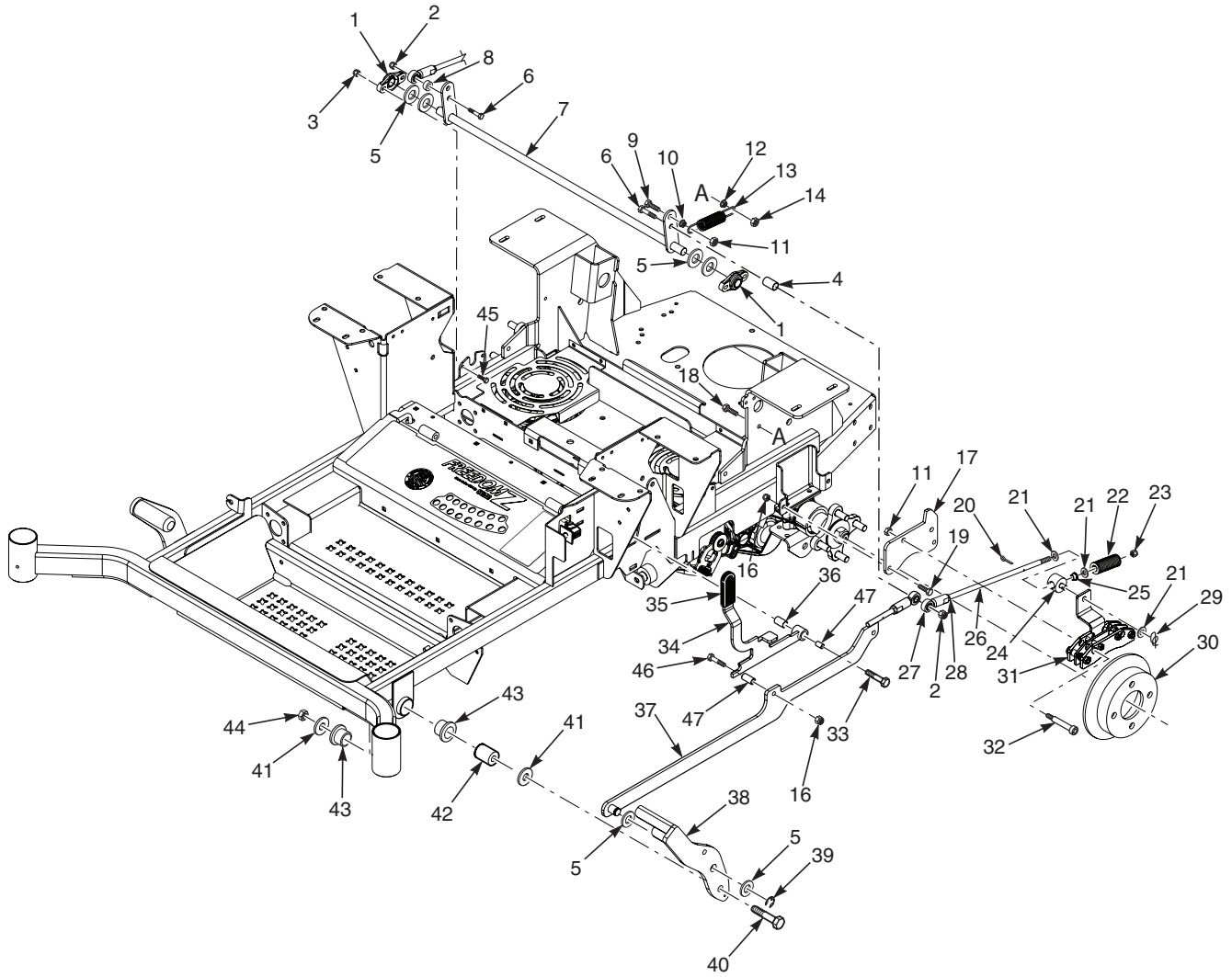

BRAKE COMPONENTS - SFZ61

Ref. No.	Part No.	Description
1	483504	Bearing
2	04021-09	Nut, Elastic Stop 3/8-16
3	04021-08	Nut, Elastic Stop 1/4-20
4	43720	Spacer
5	04040-09	Flatwasher, 5/8-.656 x 1.312 x .095
6	04001-46	Bolt, Hex Head 3/8-16 x 2-1/4"
7	452269	Weldment, Brake Lever
8	43674	Spacer
9	04001-32	Bolt, Hex Head 3/8-16 x 1-1/4"
10	04019-04	Nut, Serrated Flange 3/8-16
11	04021-05	Nut, Center Lock 3/8-16
12	04019-03	Nut, Serrated Flange 5/16-18
13	484038	Spring
14	04021-04	Nut, Center Lock 5/16-18
15	04041-07	Flatwasher, 3/8-.391 x .938 x .105
16	04021-10	Nut, Elastic Stop 5/16-18
17	425680	Mounting Bracket, Brake
18	04001-10	Bolt, Hex Head 5/16-18 x 1-1/4"
19	04001-09	Bolt, Hex Head 5/16-18 x 1"
20	04061-02	Cotter Pin, 3/32 x 3/4"
21	04040-05	Flatwasher, 3/8-.406 x .812 x .065
22	484535	Spring, Brake
23	04021-18	Nut, Elastic Stop 3/8-24
24	462452	Swivel Assembly, Brake
25	483453-23	Bearing
26	04004-54	Link, Brake
27	482330	Rod End
28	04020-25	Nut, 3/8-24 UNF Jam
29	04069-01	Pin, Rue Cotter - 3/8" Dia.
30	43853	Brake Hub
31	483701	Brake Caliper
32	04009-17	Bolt, Shoulder 1/2 x 2-1/2"
33	04009-16	Bolt, Shoulder 1/2 x 2"
34	462485	Latch Assembly, Brake (incl. # 35, #36)
35	482102	Grip, Brake Lever
36	483453-22	Bearing
37	462419	Linkage Weldment Assembly, Brake
38	452278	Brake Pedal Weldment
39	04050-01	Retaining Ring, .625 Ext. "E"
40	04001-74	Bolt, Hex Head 1/2-13 x 3"
41	04040-13	Flatwasher, 1/2-.562 x 1.375 x .109
42	43710	Sleeve
43	483453-03	Bearing
44	04021-19	Nut, Center Lock 1/2-13
45	04001-14	Bolt, Hex Head 1/4-20 x 1"
46	04001-12	Bolt, Hex Head 5/16-18 x 1-3/4"
47	43866	Sleeve, Handle Pivot

SFZ ROLL-OVER PROTECTION SYSTEM

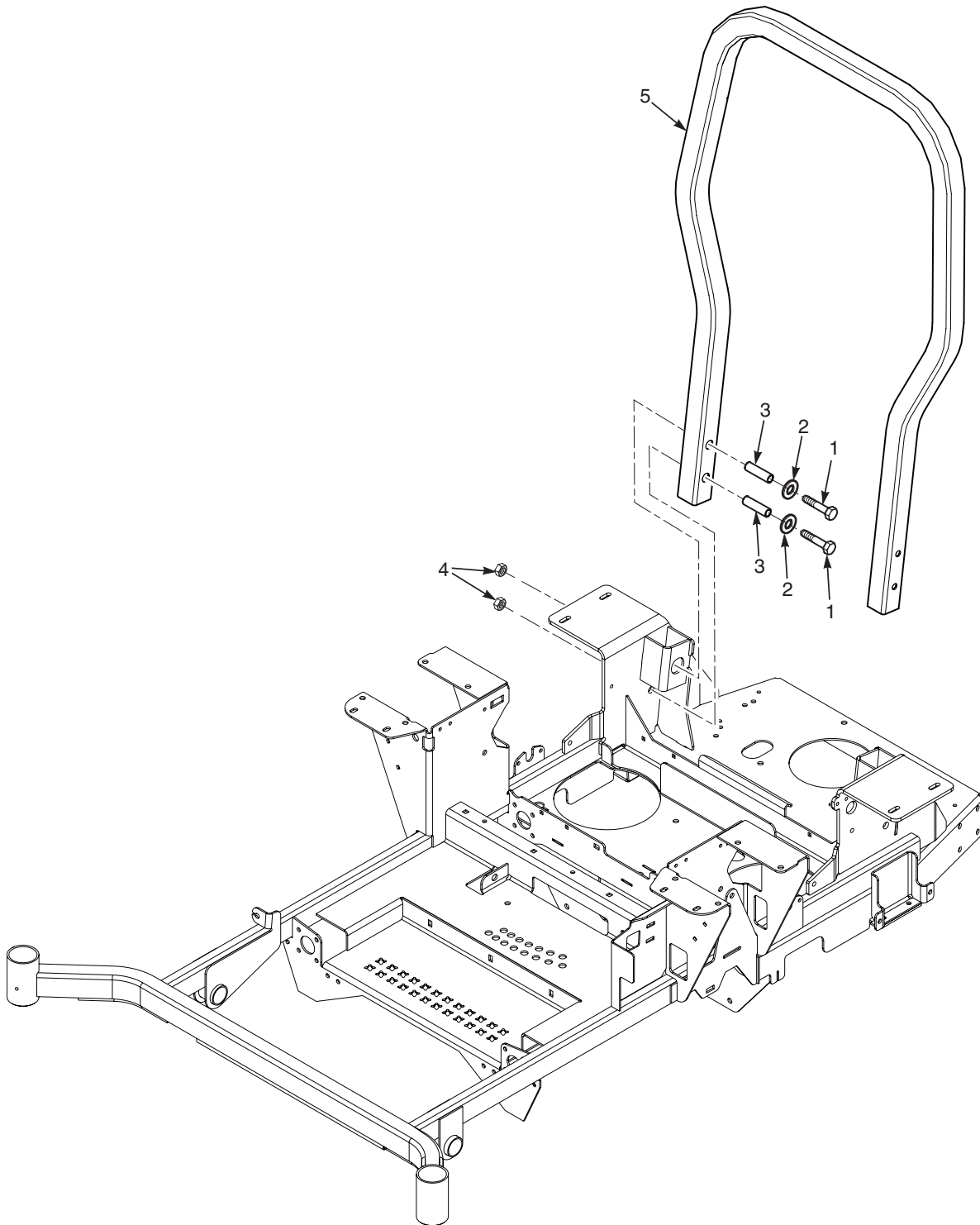

SFZ ROLL-OVER PROTECTION SYSTEM

Ref. No.	Part No.	Description
1	04001-197	Bolt, Hex Head 1/213 x 3" Gr. 8
2	04040-13	Flatwasher, 1/2 - .562 x 1.375 x .109
3	43743	Bushing, SFZ ROPS
4	04117-04	Nut, Flanged Elastic Stop, 1/2-13
5	462021	ROPS

DRIVE SYSTEM COMPONENTS - SFZ61

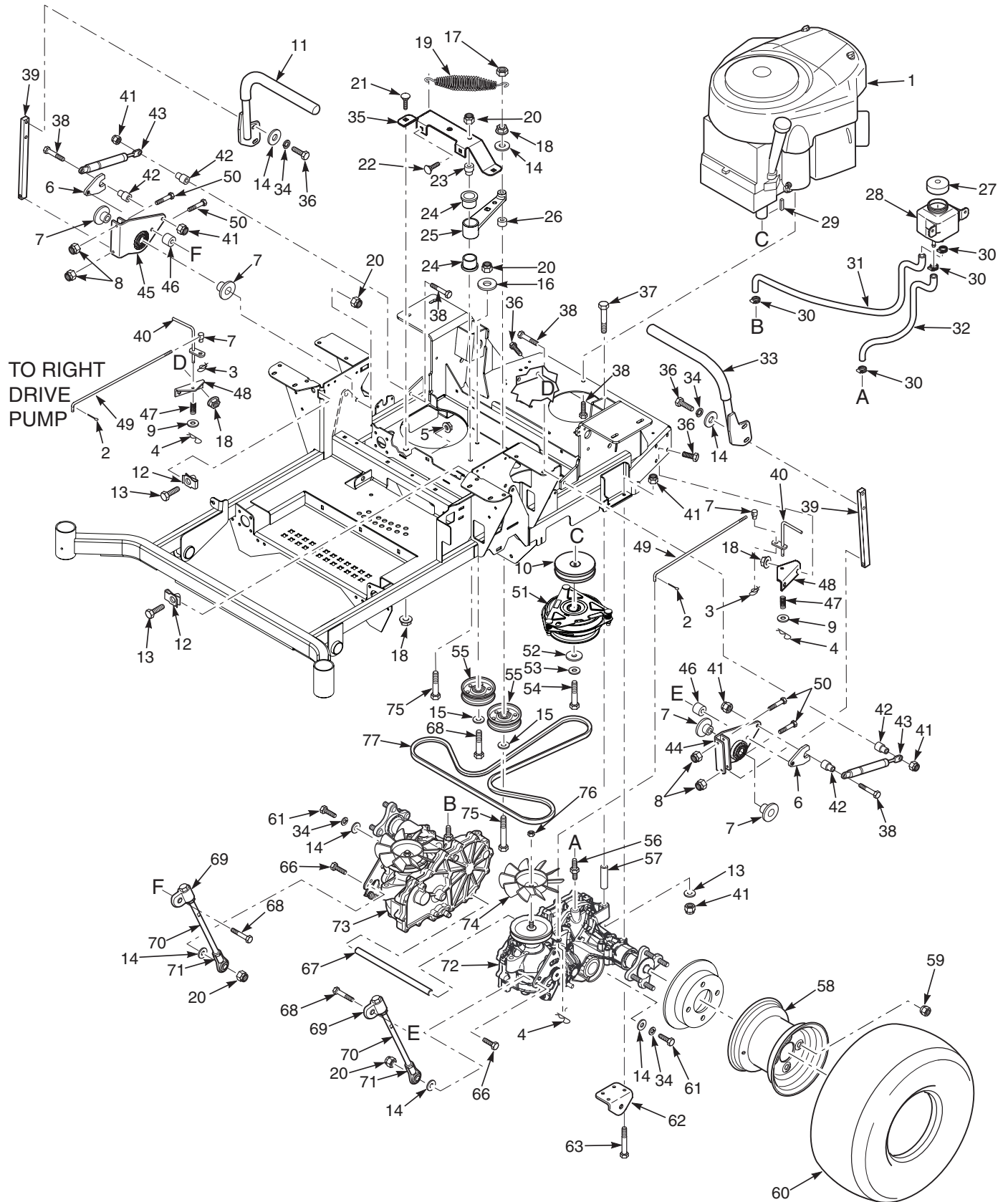

DRIVE SYSTEM COMPONENTS - SFZ61

Ref. No.	Part No.	Description
1	484456	Engine, Briggs & Stratton
	484383	Engine, Kawasaki
2	04061-01	Cotter Pin, 3/32 x 1"
3	04069-01	Pin, Rue Cotter 3/8" Dia.
4	04062-02	Hair Pin, .080 x 1.19"
5	04019-03	Nut, Serrated Flange 5/16-18
6	424687	Nut, Control Link
7	43719	Spacer, Linkage
8	04021-08	Nut, Elastic Stop 1/4-20
9	04040-14	Flatwasher, 1/4-.312 x .750 x .065
10	484373	Pulley, 5" OD - 1.125 Bore
11	462371	Handle Bar w/Grip
	484376	Grip
12	04110-03	U-Nut, 3/8-16
13	04107-01	Bolt, Hex Head 3/8-16 x 1-1/4" Special Lock
14	04041-07	Flatwasher, 3/8-.391 x .938 x .105
15	04043-04	Flatwasher, 3/8-.391 x .938 x .105 HD
16	04041-11	Flatwasher, 3/8-.406 x 1.5 x 7 GA.
17	04021-05	Nut, Center Lock 3/8-16
18	04019-04	Nut, Serrated Flange 3/8-16
19	483087	Spring, Transmission Idler
20	04021-09	Nut, Elastic Stop 3/8-16
21	04003-31	Bolt, Carriage 3/8-16 x 3/4"
22	04003-12	Bolt, Carriage 5/16-18 x 3/4"
23	43715	Shaft Pivot, Idler Arm
24	483453-04	Bearing
25	462122	Transmission Idler Arm Assembly
26	43720	Spacer, Idler Pulley
27	483514	Cap
28	483438	Reservoir Assembly
29	04063-02	Key, 1/4 x 1/4 x 2-1/4" - SFZ-61 Only
30	48136-05	Clamp, 0.87" Max Dia.
31	483431	Hose, RH Transmission
32	483432	Hose, LH Transmission
33	462370	Handle Bar Assembly, w/Grip
	484376	Grip
34	04030-04	Lockwasher, 3/8" Spring
35	424476	Support, Idler Arm
36	04001-19	Bolt, Hex Head 3/8-16 x 1"
37	04001-95	Bolt, Hex Head 5/16-18 x 5"
38	04001-11	Bolt, Hex Head 5/16-18 x 1-1/2"
39	424498	Bar, Control Lever
40	451912	Dump Valve Lever
41	04021-10	Nut, Elastic Stop 5/16-18
42	43602	Spacer, Pump Dampener
43	482794	Dampener
44	462127	Control Link, LH
45	462128	Control Link, RH
46	43674	Spacer
47	482070	Spring
48	424639	Bracket, Dump Mounting

Ref. No.	Part No.	Description
49	44162	Linkage, Dump Valve
50	04001-04	Bolt, Hex Head 1/4-20 x 1-1/2"
51	462228	Electric Clutch Assembly (61)
52	04041-28	Flatwasher, 7/16-.469 x 1.75 x .25
53	04041-28	Lockwasher, 7/16" spring
54	04102-08	Bolt, Hex Head 7/16-20 x 1-1/2" Patch SFZ-61
55	483638	Pulley, 3-1/2" Dia.
56	482800-04	Fitting, Transmission
57	43700	Spacer, Axle
58	481868	Rim w/Valve Stem (48, 52, 61)
59	04028-02	Wheel Nut, 1/2-20
60	484465	Wheel Assembly, 23 x 9.5-12
	484466	Tire, 23 x 9.5-12
	484056	Rim
61	04001-46	Bolt, Hex Head 3/8-16 x 2-1/4"
62	424489	Bracket, Pusharm Link
63	04001-49	Bolt, Hex Head 5/16-18 x 3"
64	HG51190	Clip, Brake Lever (order through Hydro-Gear)
65	HG52639	Lever, Brake (order through Hydro-Gear)
66	04001-32	Bolt, Hex Head 3/8-16 x 1-1/4"
67	43701	Spacer, Axle
68	04001-45	Bolt, Hex Head 3/8-16 x 2"
69	483563	Rod End, Adjustable 3/8-24
	04020-25	Nut, Jam 3/8-24 UNF RH
70	484405	Linkage, Pump
71	483575	Stake, Rod End Assembly
72	484454	Transaxle Assy., (ZS-KCEE-3LKG-11XX)
73	484455	Transaxle Assy., (ZS-GCEE-3LKF-11XX)
74		Fan (order through Hydro-Gear)
75	04001-54	Bolt, Hex Head 3/8-16 x 3"
76	HG44133	Fan Nut (order through Hydro-Gear)
77	484372	Belt, Transmission Drive

EXHAUST AND ELECTRICAL SYSTEM - SFZ61

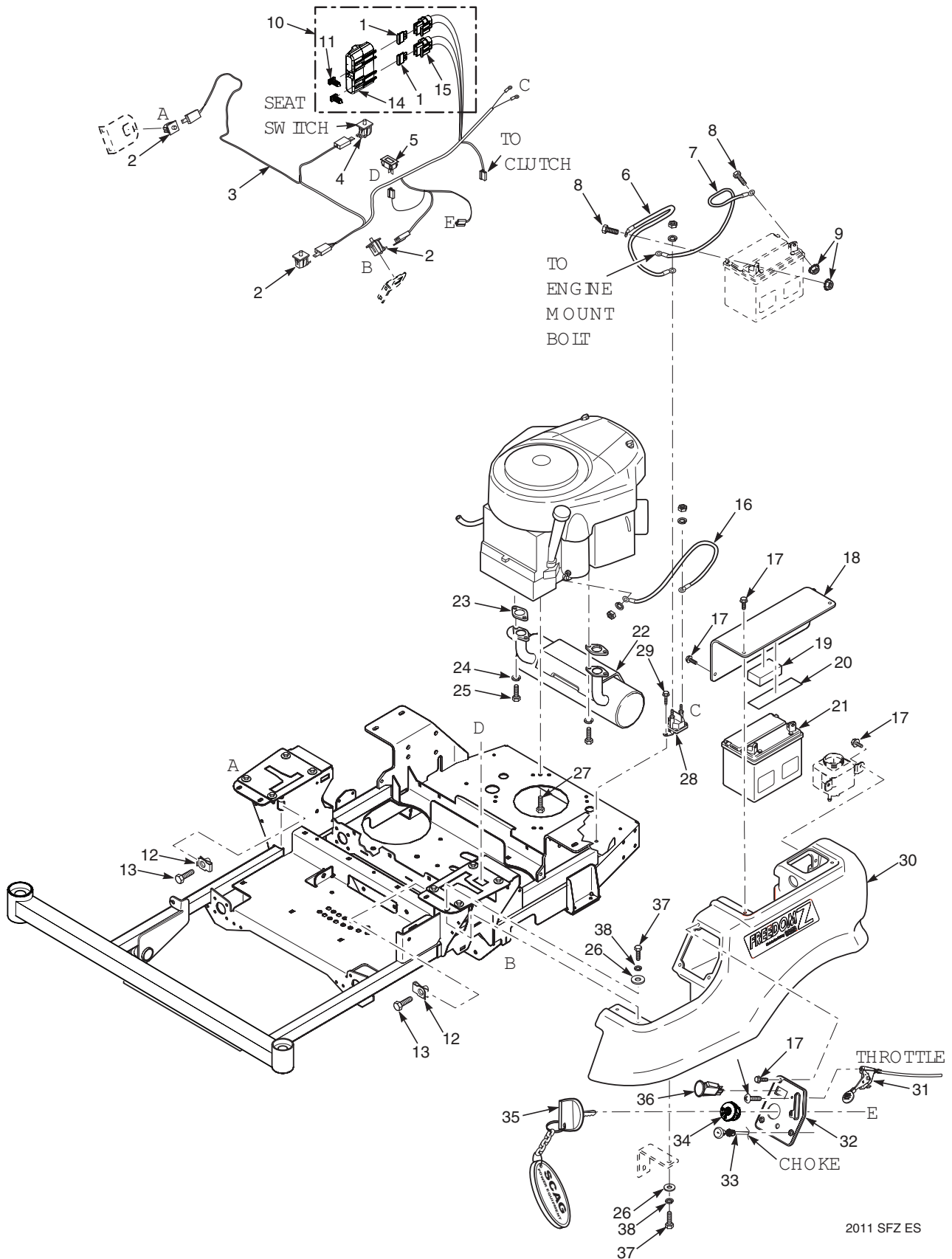

2011 SFZ ES

EXHAUST AND ELECTRICAL SYSTEM - SFZ61

Ref. No.	Part No.	Description
1	48298	Fuse, 20 amp
2	483473	Switch
3	484433	Wire Harness, Main
	483628	Wire Harness Adapter, Kawasaki (not shown)
4	483474	Switch, Seat
5	483537	Hourmeter
6	48029-13	Battery Cable, Red 25"
7	48029-11	Battery Cable, Black 27"
8	04001-44	Bolt, Hex Head 1/4-20 x 1/2"
9	04020-02	Nut, 1/4-20
10	483642	Double Fuse Assy. (incl. items 1, 14, 15, 46)
11	482588	Clip, Wire
12	04110-03	U-Nut, 3/8-16
13	04107-03	Bolt, Hex Head 3/8-16 x 1-1/4" Special Lock
14	483571	Cover, Sealed Double
15	483629	Fuse Holder
16	48029-09	Battery Cable, Red 9"
17	04017-04	Bolt, Hex Head 1/4-20 x 1/2" Serr. Flange
18	461996	Battery Cover (incl. items 19 & 20)
19	483452	Pad, Battery Hold Down
20	483508	Rubber Pad
21	483665	Battery (not avail. through Scag)
22	483381	Muffler, Briggs & Stratton
	484209	Muffler, Kawasaki
23	**	Exhaust Gasket
24	**	Lockwasher
25	**	Bolt
26	04040-15	Flatwasher, 5/16-.375 x .875 x .083
27	04001-32	Bolt, Hex Head 3/8-16 x 1-1/4" (Kawasaki)
	04030-04	Lockwasher, 3/8" Spring (Kawasaki)
	04001-11	Bolt, Hex Head 5/16-18 x 1-1/2" (Briggs)
	04019-03	Nut, 5/16-18 Serrated Flange
	04031-03	Lockwasher, 5/16" Spring (Briggs)
	04011-07	Capscrew, Hex Head 3/8-16 x 1-1/4" Self Tap (Briggs)

Ref. No.	Part No.	Description
28	483278	Solenoid
29	04011-14	Bolt, Self Tapping 1/2-20 x 3/4" Shakeproof
30	483364	Tank, LH
31	483434	Throttle Cable
32	462036	Instrument Panel w/Decal
33	483435	Choke Cable
34	483472	Ignition Switch
35	483366	Key, Ignition
	483609	Key w/Shroud
	462069	Key Assembly w/Fob
36	483957	PTO Switch
37	04001-08	Bolt, Hex Head 5/16-18 x 3/4"
38	04030-03	Lockwasher, 5/16" Spring

** Available through individual engine manufacturer.

SFZ61 FUEL SYSTEM

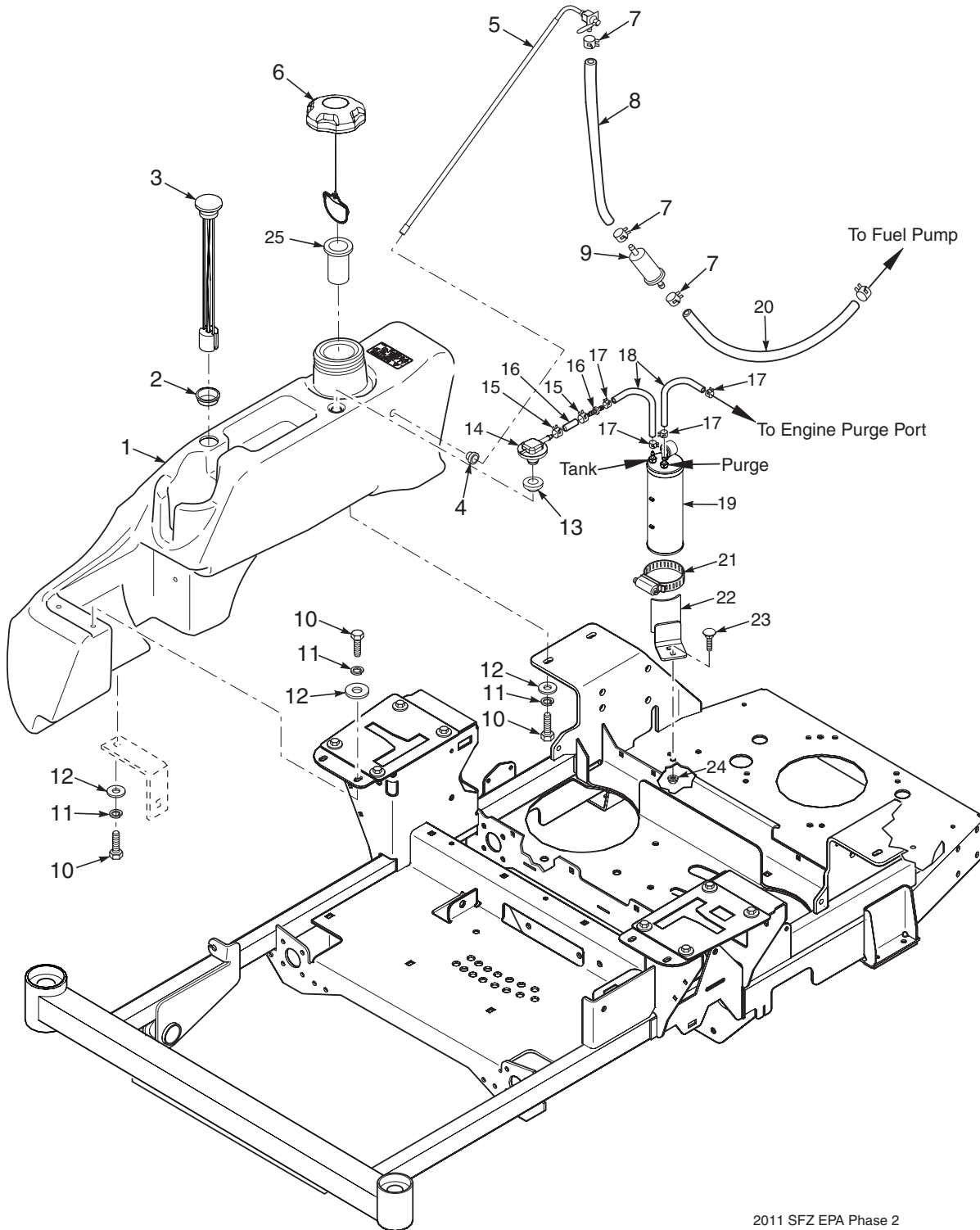

2011 SFZ EPA Phase 2

SFZ61 FUEL SYSTEM

Ref. No.	Part No.	Description
1	462292	Fuel Tank Assembly
2	483536	Grommet
3	484243	Fuel Gauge Assembly
4	482571	Bushing, .56 Dia. Viton
5	483555	Fuel Tube Assembly
6	484286	Fuel Cap, Tethered
7	48059-01	Clamp, Fuel Hose 1/4"
8	483617	Fuel Hose, 1/4" Non-Perm (order by inch)
9	*	Fuel Filter
10	04001-08	Bolt, Hex Head 5/16-18 x 3/4"
11	04030-03	Lockwasher, 5/16" Spring
12	04040-15	Flatwasher, 5/16-.375 x .875 x .083
13	484285	Grommet, Viton
14	484333	Remote Vent
15	48059-02	Clamp, Fuel Hose 7/32"
16	484347	Hose, 1/4" Vapor Recovery (order by inch)
17	48059-05	Clamp, Vapor Recovery Hose
18	484345	Hose, 3/16" (order by inch)
19	484342	Carbon Canister
20	*	Fuel Hose
21	48136-17	Clamp, Hose
22	452226	Bracket Weldment, SFZ48/52
	452233	Bracket Weldment, SFZ61
23	04003-12	Bolt, Carriage 5/16-18 x 3/4"
24	04019-03	Nut, Serrated Flange 5/16-18
25	484279-01	Tube, Fuel Tank Insert
26	484343-01	Mender, 1/4 x 3/16 w/0.02 Hole

* = Available through engine manufacturer only.

ZT-3400 HYDRAULIC AXLE ASSEMBLY -SFZ61

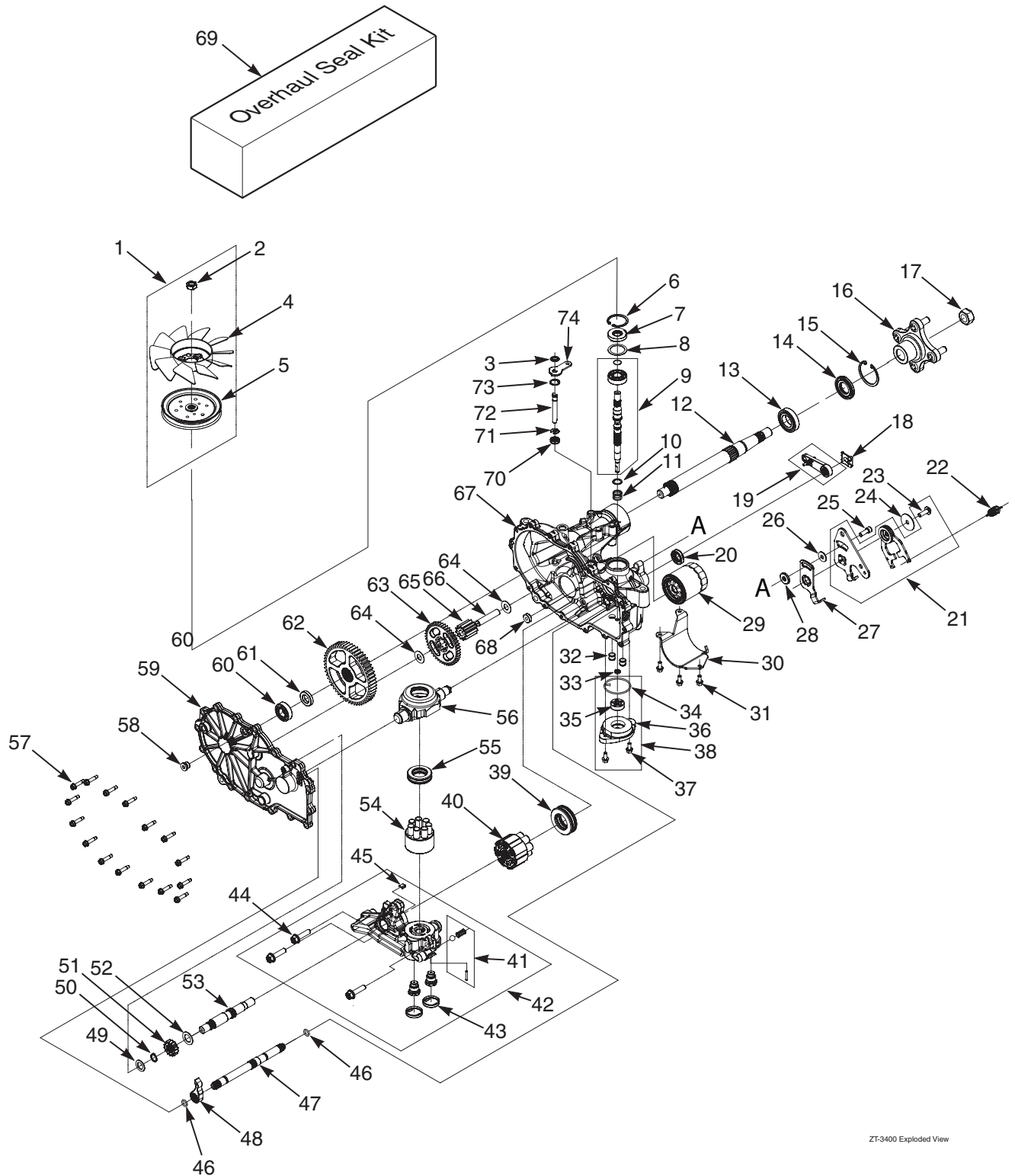

ZT-3400 HYDRAULIC AXLE ASSEMBLY - SFZ61

Ref. No.	Part No.	Description
1	HG71907	Kit, Fan & Pulley
2	HG44133	Nut, Elastic Stop 1/2-20
3	HG51523	Washer, OD Slotted .53 x 1.63 x .06
4	HG52747	Fan, 7" (10 Blade)
5	HG53435	Pulley"
6	HG53029	Ring, Retaining
7	HG51161	Seal, Lip 17 x 40 x 7
8	HG50951	Washer, 1.23 x 1.56 x .04
9	HG71978	Kit, Input Shaft
10	HG2003017	Washer, Flat .59 x .79 x .04
11	HG2003014	Spring, Block
12	HG53528	Shaft, Axle
13	HG50771	Bearing, Ball 25.4 x 52 x 15
14	HG50772	Seal, Lip 1 x 2.049 x .375
15	HG50859	Ring, Retaining 2.06 Internal
16	HG71405	Hub, 4-Bolt
17	HG50863	Nut, Hex Lock 3/4-16
18	HG52027	Clip, Retaining
19	HG52639	Handle, Brake Actuating
20	HG51140	Seal, Lip 12 x 32 x 7
21	HG71595	Kit, RTN Bi-Directional (Left Side)
	HG71598	Kit, RTN Bi-Directional (Right Side)
22	HG51605	Spring, RTN
23	HG51812	Bolt, Hex Head Cap Screw 5/16-24 x 1" Patch
24	HG51950	Washer, .343 x 1.5 x .062
25	HG51616	Bolt, Hex Head Cap Screw 5/16-24 x 1" Patch
26	HG44130	Washer, .34 x .88 x .06
27	HG51945	Arm, Neutral (Right Side)
	HG51946	Arm, Neutral (Left Side)
28	HG52527	Spacer, .320 x 1.005 x .179
29	HG52114	Filter, Oil
30	HG52257	Guard, Filter (Right Side)
	HG52247	Guard, Filter (Left Side)
31	HG53464	Screw, Hex Flange 1/4-20 x .625
32	HG52157	Tibe, Connecting
33	HG53456	Seal, Lip 8 x 12 x 3-VC
34	HG52250	O-Ring, -.137 x .103 x 2.050
35	HG50273	Gerotor Assembly (1.9 cc)
36	HG53468	Cover, Charge Pump
37	HG53464	Screw, Hex Flange 1/4-20 x .625
38	HG71977	Kit, Charge Pump
39	HG51462	Bearing, Thrust

Ref. No.	Part No.	Description
40	HG71579	Assembly, Cylinger Block
41	HG71436	Kit, Charge Relief
42	HG71972	Kit, Center Section (Right Side)
	HG71973	Kit, Center Section (Left Side)
43	HG52162	Seal, Plug 1.250 x .250
44	HG52137	HFHCS, 3/8-16 X 1-1/2" Patch
45	HG51448	Plate, By-Pass
46	HG51804	O-Ring, -.111 x .103 x 424
47	HG42640	Shaft, Brake
48	HG52776	Pawl, Brake
49	HG44371	Washer, .63 x 1 x .05
50	HG44145	Ring, Retaining .625
51	HG52342	Gear, 13T Steel
52	HG51069	Washer, .72 x 1.16 x .04
53	HG52150	Shaft, Motor
54	HG71971	Assembly, Block 7 Piston
55	HG53502	Bearing, Thrust
56	HG51048	Trunnion, Swashplate
57	HG53246	HFHCS, 1/4-20 x 1-1/8"
58	HG9005110	Plug, 9/16-18
	-5600	
59	HG71990	Kit, Cover (Right Side)
	HG71992	Kit, Cover (Left Side)
60	HG44121	Bearing, Ball .75 x 40 x 12
61	HG53336	Spacer, .750 x 1.320 x .257
62	HG43327	Gear, 54T
63	HG52110	Gear, 45T
64	HG50132	Washer, .5 X 1 X .03
65	HG52341	Gear, 14T Steel
66	HG51083	Jackshaft Pin
67	HG72025	Kit, Housing Main (Right Side)
	HG72026	Kit, Housing Main (Left Side)
68	HG51100	Magnet, Ring
69	HG71976	Seal Kit
70	HG51626	Seal, Lip .375 x .75 x .25
71	HG51628	Ring, Retaining .375 External
72	HG52136	Rod, By-Pass
73	HG51677	Ring, Retaining .750 Internal
74	HG51629	Arm, By-Pass
75	HG51630	Ring, Retaining .375 External

REPLACEMENT DECALS AND INFORMATION PLATES

WARNING
INSTALL BELT COVER BEFORE OPERATING MACHINE
 READ OPERATOR'S MANUAL
483402

WARNING
 DO NOT OPERATE WITHOUT DISCHARGE CHUTE, MULCHING KIT, OR ENTIRE GRASS CATCHER INSTALLED
483405

IMPORTANT
 Operation on slopes can be hazardous. This machine was originally equipped with a Rollover Protection Device with a Roll Bar and Seat Belt. See your dealer if either is missing or damaged.
483425

DANGER
SPINNING BLADES
KEEP CLEAR
BLADE CONTACT & THROWN OBJECTS CAN INJURE

FORWARD
F
R
 REVERSE

WARNING
ROTATING BLADES AND BELTS
 * Keep hands, feet & clothing clear
 * Keep all guards in place
 * Shut off engine & disengage blade clutch before servicing
 * Use caution in directing discharge
 * Read instruction manual before operating
DO NOT OPERATE UNLESS GRASS CATCHER, MULCHING KIT OR DISCHARGE CHUTE IS INSTALLED
483406

WARNING
 Replace seat only with Scag approved seat with seat mounting provisions and Scag approved seat belts. Failure to follow these directions could result in injury or death in the event of a rollover.
483418

61
COMMERCIAL GRADE

IMPORTANT ADJUSTMENT PROCEDURES
 READ OPERATORS MANUAL FOR MORE DETAILS
 Check tire pressure - Drive tires-8 psi
 - Caster tires-25 psi

FREE WHEEL OPERATION
 To move machine without running engine, pull both dump valve rods up and back (located at rear of machine) and latch. Pull rods forward and latch into front slot to operate mower.

NEUTRAL ADJUSTMENT
 Adjusting Nut
 Jamnut

TRACKING ADJUSTMENT
 Control Lever
 Stop Bolt

HYDRAULIC FLUID LEVEL
 Check hydraulic fluid level while fluid is cool. Fluid level should be in sight window. Fill with 20W50 motor oil only.

IMPORTANT
 Do not overfill. Room for hot fluid expansion must be allowed or resulting expansion may cause leaks in the system.

If machine pulls to right, adjust LH control stop bolt CW (Inward) to slow left wheel down.
 If machine pulls to left, adjust RH control stop bolt CW (Inward) to slow right wheel down.
483660

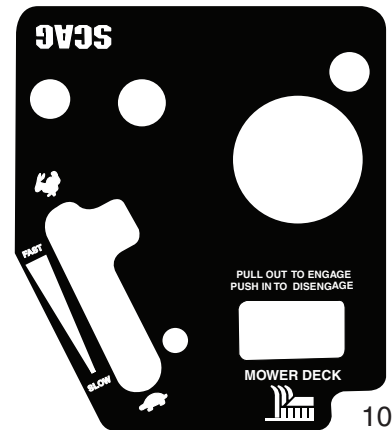

SCAG FREEDOM Z

MANUFACTURED UNDER ONE OR MORE OF THE FOLLOWING PATENTS:

 PATENTS PENDING

START/DRIVE PROCEDURE
 Engage parking brake, drive release, engage parking brake, start engine, select forward or reverse with drive control levers.

DECK LATCH RELEASE

FREEDOM Z
 Made in the USA by SCAG

MADE IN THE USA
 PLUMBLY
 HARTFORD, CT
 MOOREVILLE, VA

WARNING
 AVOID SERIOUS INJURY OR DEATH. Read the Operator's Manual and observe all safety precautions. Do not touch moving parts until you have stopped the machine and disengaged the blade. Stop blades and deck when starting. Do not touch deck or blades until they have stopped. Do not touch deck or blades until you have stopped the machine and disengaged the blade. Do not touch deck or blades until they have stopped. Do not touch deck or blades until they have stopped.

REPLACEMENT DECALS AND INFORMATION PLATES

Ref. No.	Part No.	Description
1	483402	Decal, Belt Cover
2	483405	Decal, Warning
3	483425	Decal, ROPS
4	483505	Decal, Spinning Blades
5	481568	Decal, Traction Control
6	483633	Decal, Seat Replacement
7	484044	Decal, 61 Commercial
8	483406	Decal, Knives
9	483660	Decal, Adjustment SFZ
10	483499	Decal, Instrument Panel
11	483501	Decal, Front SFZ
12	484372	Decal, Cutting Height - SFZ61
13	483044	Decal, Patent
*	462155	Spanish Decal Kit - SFZ (not shown)
*	01411	DVD Video, Tips for Safe Operation of Your Scag Zero-Turn Mower (not shown)

ELECTRICAL SCHEMATIC

