

SCAG

POWER EQUIPMENT

OPERATOR'S MANUAL



Freedom Z

Models: SFZ36-17KA
SFZ36-20BS
SFZ48-19KA
SFZ48-26BS
SFZ52-19KA
SFZ52-26BS
SFZ61-28BS

Congratulations on owning a Scag mower! This manual contains the operating instructions and safety information for your Scag mower. Reading this manual can provide you with assistance in maintenance and adjustment procedures to keep your mower performing to maximum efficiency. The specific models that this book covers are listed on the inside cover. Before operating your machine, please read all the information enclosed.



WARNING

FAILURE TO FOLLOW SAFE OPERATING PRACTICES MAY RESULT IN SERIOUS INJURY OR DEATH.

- Read this manual completely as well as other manuals that came with your mower.
- DO NOT operate on steep slopes. To check a slope, attempt to back up it (with the cutter deck down). If the machine can back up the slope without the wheels slipping, reduce speed and use extreme caution.
- Under no circumstances should the machine be operated on slopes greater than 15 degrees. ALWAYS FOLLOW OSHA APPROVED OPERATION.
- DO NOT mow on wet grass. Wet grass reduces traction and steering control.
- Keep all shields in place, especially the grass discharge chute.
- Before performing any maintenance or service, stop the machine and remove the spark plug wire and ignition key.
- If a mechanism becomes clogged, stop the engine before cleaning.
- Keep hands, feet and clothing away from power-driven parts.
- Keep others off the mower (only one person at a time)

REMEMBER - YOUR MOWER IS ONLY AS SAFE AS THE OPERATOR!

HAZARD CONTROL AND ACCIDENT PREVENTION ARE DEPENDENT UPON THE AWARENESS, CONCERN, PRUDENCE, AND PROPER TRAINING OF THE PERSONNEL INVOLVED IN THE OPERATION, TRANSPORT, MAINTENANCE, AND STORAGE OF THE EQUIPMENT.

This manual covers the operating instructions and illustrated parts list for:

SFZ36-17KA	with a serial number of	E2800001 to E2899999
SFZ36-20BS	with a serial number of	E3000001 to E3099999
SFZ48-19KA	with a serial number of	D8600001 to D8699999
SFZ48-26BS	with a serial number of	D8500001 to D8599999
SFZ52-19KA	with a serial number of	D8800001 to D8899999
SFZ52-26BS	with a serial number of	D8700001 to D8799999
SFZ61-28BS	with a serial number of	E6900001 to E6999999
SMFZ-36	with a serial number of	E3100001 to E3199999
SMFZ-48	with a serial number of	D9700001 to D9799999
SMFZ-52	with a serial number of	D9800001 to D9899999
SMFZ-61	with a serial number of	E7000001 to E7099999

Always use the entire serial number listed on the serial number tag when referring to this product.

Table of Contents

SECTION 1 - GENERAL INFORMATION	1
1.1 INTRODUCTION.....	1
1.2 DIRECTION REFERENCE	1
1.3 SERVICING THE ENGINE AND DRIVE TRAIN COMPONENTS.....	1
1.4 SYMBOLS	2
SECTION 2 - SAFETY INFORMATION	3
2.1 INTRODUCTION.....	3
2.2 SIGNAL WORDS	3
2.3 BEFORE OPERATION CONSIDERATIONS.....	3
2.4 OPERATION CONSIDERATIONS.....	4
2.5 ROLL-OVER PROTECTION SYSTEM	6
2.6 MAINTENANCE CONSIDERATIONS & STORAGE	7
2.7 USING A SPARK ARRESTOR.....	7
2.8 SAFETY AND INSTRUCTIONAL DECALS	8
SECTION 3 - SPECIFICATIONS	9
3.1 ENGINE	9
3.2 ELECTRICAL	9
3.3 TRACTOR	9
3.4 CUTTER DECK	10
3.5 HYDRAULIC SYSTEM	10
3.6 WEIGHTS AND DIMENSIONS	10
SECTION 4 - OPERATING INSTRUCTIONS	11
4.1 CONTROLS AND INSTRUMENT IDENTIFICATION	11
4.2 SAFETY INTERLOCK SYSTEM	12
4.3 INITIAL RUN-IN PROCEDURES.....	12
4.4 STARTING THE ENGINE	13
4.5 GROUND TRAVEL AND STEERING	13
4.6 ENGAGING THE DECK DRIVE (CUTTER BLADES).....	14
4.7 HILLSIDE OPERATION.....	15
4.8 PARKING THE MOWER.....	15
4.9 AFTER OPERATION	15
4.10 REMOVING CLOGGED MATERIAL	15
4.11 MOVING MOWER WITH ENGINE STOPPED	16
4.12 RECOMMENDATIONS FOR MOWING	16
4.13 ADJUSTING CUTTING HEIGHT.....	16
4.14 TOWING (OPTIONAL HITCH ACCESSORY) (NOT AVAILABLE FOR SFZ36)	17
SECTION 5 - TROUBLESHOOTING CUTTING CONDITIONS	18

SECTION 6 - ADJUSTMENTS	21
6.1 PARKING BRAKE ADJUSTMENT	21
6.2 TRAVEL ADJUSTMENTS	22
6.3 THROTTLE CONTROL AND CHOKE ADJUSTMENTS	23
6.4 BELT ADJUSTMENT	23
6.5 BELT ALIGNMENT.....	23
6.6 CUTTER DECK ADJUSTMENTS	24
6.7 ELECTRIC CLUTCH ADJUSTMENT	26
SECTION 7 - MAINTENANCE.....	27
7.1 MAINTENANCE CHART - RECOMMENDED SERVICE INTERVALS	27
7.2 HYDRAULIC SYSTEM	28
7.3 ENGINE OIL	29
7.4 ENGINE FUEL SYSTEM	30
7.5 ENGINE AIR CLEANER.....	31
7.6 BATTERY.....	31
7.7 DRIVE BELTS.....	32
7.8 CUTTER BLADES.....	33
7.9 TIRES.....	34
7.10 BODY, DECK, AND UPHOLSTERY	34
SECTION 8 - ILLUSTRATED PARTS LIST	35
8.1 SCAG APPROVED ATTACHMENTS AND ACCESSORIES.....	35
36 CUTTER DECK	36
48, 52 & 61 CUTTER DECKS	38
CUTTER DECK CONTROLS - SFZ36	40
CUTTER DECK CONTROLS - SFZ48 & SFZ52.....	42
CUTTER DECK CONTROLS - SFZ61	44
SHEET METAL COMPONENTS	46
SFZ ROLL-OVER PROTECTION SYSTEM	48
DRIVE SYSTEM COMPONENTS - SFZ36.....	50
DRIVE SYSTEM COMPONENTS - SFZ48, SFZ52 & SFZ61	52
FUEL AND ELECTRICAL SYSTEM - SFZ36	54
FUEL AND ELECTRICAL SYSTEM - SFZ48, SFZ52 & SFZ61	56
ZT-3100 HYDRAULIC AXLE ASSEMBLY	58
ZT-3400 HYDRAULIC AXLE ASSEMBLY -SFZ61.....	60
REPLACEMENT DECALS AND INFORMATION PLATES	62
ELECTRICAL SCHEMATIC	64
LIMITED WARRANTY - SFZ	FOLLOWING SECTION 8

GENERAL INFORMATION

1.1 INTRODUCTION

Your mower was built to the highest standards in the industry. However, the prolonged life and maximum efficiency of your mower depends on you following the operating, maintenance and adjustment instructions in this manual.

If additional information or service is needed, contact your Scag Power Equipment Dealer.

We encourage you to contact your dealer for repairs. All Scag dealers are informed of the latest methods to service this equipment and provide prompt and efficient service in the field or at their service shop. They carry a full line of Scag service parts.

THE REPLACEMENT OF ANY PART ON THIS PRODUCT BY OTHER THAN THE MANUFACTURER'S AUTHORIZED REPLACEMENT PART MAY ADVERSELY AFFECT THE PERFORMANCE, DURABILITY OR SAFETY OF THIS PRODUCT.

USE OF OTHER THAN ORIGINAL SCAG REPLACEMENT PARTS WILL VOID THE WARRANTY.

When ordering parts, always give the model and serial number of your mower. The serial number plate is located where shown in Figure 1-1.

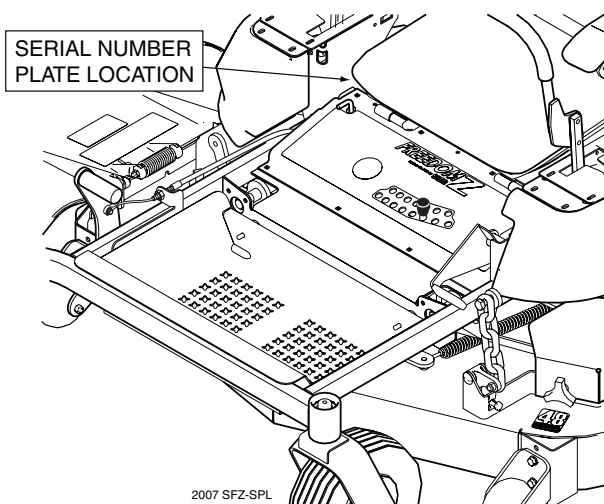

Figure 1-1. Mower Serial Number Plate Location

USE ONLY SCAG APPROVED ATTACHMENTS AND ACCESSORIES.

Attachments and accessories manufactured by companies other than Scag Power Equipment are not approved for use on this machine. See Section 8, Paragraph 8-1.

WARNING

For pictorial clarity, some illustrations and figures in this manual may show shields, guards or plates open or removed. Under no circumstances should your mower be operated without these devices in place.

All information is based upon product information available at the time of approval for printing. Scag Power Equipment reserves the right to make changes at any time without notice and without incurring any obligation.



















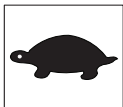

1.2 DIRECTION REFERENCE

The “Right” and “Left”, “Front” and “Rear” of the machine are referenced from the operator’s right and left when seated in the normal operating position and facing the forward travel direction.

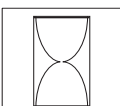
1.3 SERVICING THE ENGINE AND DRIVE TRAIN COMPONENTS

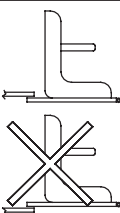
The detail servicing and repair of the engine, hydraulic pumps and gearboxes are not covered in this manual; only routine maintenance and general service instructions are provided. For service of these components during the limited warranty period, it is important to contact your Scag dealer or find a local authorized servicing agent of the component manufacturer. Any unauthorized work done on these components during the warranty period may void your warranty.

1.4 SYMBOLS

SYMBOL	DESCRIPTION	SYMBOL	DESCRIPTION
	Choke		Transmission
	Parking Brake		Spinning Blade
	On/Start		Spring Tension on Idler
	Off/Stop		Oil
	Falling Hazard		Thrown Object Hazard
	Fast		Slow
	Continuously Variable - Linear		Cutting Element - Basic Symbol
	Pinch Point		Cutting Element - Engage
	Hour meter/Elapsed Operating Hours		Cutting Element - Disengage
	STT MODELS Seat must be installed under the seat hold down bracket during installation. Failure to secure the seat under the hold down bracket could result in serious injury or death in a roll over.		CE Mark
	Thrown Object Hazard Keep Bystanders Away		Read Operator's Manual

SAFETY INFORMATION

2.1 INTRODUCTION

Your mower is only as safe as the operator. Carelessness or operator error may result in serious bodily injury or death. Hazard control and accident prevention are dependent upon the awareness, concern, prudence, and proper training of the personnel involved in the operation, transport, maintenance and storage of the equipment. Make sure every operator is properly trained and thoroughly familiar with all of the controls before operating the mower. The owner/user can prevent and is responsible for accidents or injuries occurring to themselves, other people or property.

READ THIS OPERATOR'S MANUAL BEFORE ATTEMPTING TO START YOUR MOWER.

A replacement manual is available from your authorized Scag Service Dealer or by contacting Scag Power Equipment, Service Department at P.O. Box 152, Mayville, WI 53050 or contact us via the Internet at www.scag.com. The manual for this machine can be downloaded by using the model and serial number or use the contact form to make your request. Please indicate the complete model and serial number of your Scag product when requesting replacement manuals.

2.2 SIGNAL WORDS



This symbol means **“Attention! Become Alert! Your Safety is Involved!”** The symbol is used with the following signal words to attract your attention to safety messages found on the decals on the machine and throughout this manual. The message that follows the symbol contains important information about safety. To avoid injury and possible death, carefully read the message! Be sure to fully understand the causes of possible injury or death.

SIGNAL WORD:

It is a distinctive word found on the safety decals on the machine and throughout this manual that alerts the viewer to the existence and relative degree of the hazard.

DANGER

The signal word “DANGER” denotes that an extremely hazardous situation exists on or near the machine that could result in high probability of death or irreparable injury if proper precautions are not taken.

WARNING

The signal word “WARNING” denotes that a hazard exists on or near the machine that can result in injury or death if proper precautions are not taken.

CAUTION

The signal word “CAUTION” is a reminder of safety practices on or near the machine that could result in personal injury if proper precautions are not taken.

Your safety and the safety of others depends significantly upon your knowledge and understanding of all correct operating practices and procedures of this machine.

2.3 BEFORE OPERATION CONSIDERATIONS

1. NEVER allow children to operate this riding mower. Do not allow adults to operate this machine without proper instructions.
2. Do not mow when children and/or others are present. Keep children out of the mowing area and in the watchful care of a responsible adult other than the operator. Be alert and turn machine off if a child enters the area.
3. DO NOT allow children to ride or play on the machine, it is not a toy.
4. Clear the area to be mowed of objects that could be picked up and thrown by the cutter blades.
5. DO NOT carry passengers.
6. DO NOT operate the machine under the influence of alcohol or drugs.

7. If the operator(s) or mechanic(s) cannot read English or Spanish, it is the owner's responsibility to explain this material to them.
8. DO NOT wear loose fitting clothing. Loose clothing, jewelry or long hair could get tangled in moving parts. Do not operate the machine wearing shorts; always wear adequate protective clothing including long pants. Wearing safety glasses, safety shoes and a helmet is advisable and is required by some local ordinances and insurance regulations.

WARNING

Always wear hearing protection. Operating this machine over prolonged periods of time can cause loss of hearing.

9. Keep the machine and attachments in good operating condition. Keep all shields and safety devices in place. If a shield, safety device or decal is defective or damaged, repair or replace it before operating the machine.

WARNING

This machine is equipped with an interlock system intended to protect the operator and others from injury. This is accomplished by preventing the engine from starting unless the deck drive is disengaged, the steering control levers are in the neutral position and the operator is in the seat. The system shuts off the engine if the operator leaves the seat with the deck drive engaged and/or the steering control levers are not in the neutral position and the parking brake is not engaged. Never operate equipment with the interlock system disconnected or malfunctioning.

10. Be sure the interlock switches are functioning correctly.
11. Fuel is flammable; handle it with care. Fill the fuel tank outdoors. Never fill it indoors. Use a funnel or spout to prevent spillage. Clean up any spillage before starting the engine.

12. DO NOT add fuel to a running or hot engine. Allow the engine to cool for several minutes before adding fuel. Never fuel indoors or inside enclosed trailers.
13. Keep flammable objects (cigarettes, matches, etc.), open flames and sparks away from the fuel tank and fuel container. Use only approved containers.
14. Equipment must comply with the latest requirements per SAE J137 and/or ANSI/ASAE S279 when driven on public roads.

- NOTE -

If the mower is driven on public roads, it must comply with state and local ordinances as well as SAE J137 and/or ANSI/ASAE S279 requirements. Contact your local authorities for regulations and equipment requirements.

15. Do not operate without the side discharge chute installed and in the down position or with an optional grass catcher or mulch plate completely installed.
16. Check the blade mounting bolts at frequent intervals for proper tightness.
17. Make sure all hydraulic fluid connections are tight and all hydraulic hoses and lines are in good condition before starting the machine.

2.4 OPERATION CONSIDERATIONS

1. Know the function of all controls and how to stop quickly.

WARNING

DO NOT operate on steep slopes. To check a slope, attempt to back up it (with the cutter deck down). If the machine can back up the slope without the wheels slipping, reduce speed and use extreme caution. Under no circumstances should the machine be operated on slopes greater than 15 degrees. ALWAYS FOLLOW OSHA APPROVED OPERATION.

2. Reduce speed and exercise extreme caution on slopes and in sharp turns to prevent tipping or loss of control. Be especially cautious when changing directions on slopes.

Section 2

3. To prevent tipping or loss of control, start and stop smoothly, avoid unnecessary turns and travel at reduced speed. Use caution when operating the mower on an incline with the optional grass catcher installed.
4. When using any attachment, never direct the discharge of material toward bystanders or allow anyone near the machine while in operation.
5. Before attempting to start the engine, with the operator in the seat, disengage power to the cutter deck, place the steering control levers in the neutral position and engage the parking brake.
6. If the mower discharge ever plugs, shut off the engine, remove the ignition key, and wait for all movement to stop before removing the obstruction.

 **WARNING**

DO NOT use your hand to dislodge the clogged discharge chute. Use a stick or other device to remove clogged material after the engine has stopped running and the blades have stopped turning.

7. Be alert for holes, rocks, roots and other hidden hazards in the terrain. Keep away from any drop-offs. Beware of overhead obstructions (low limbs, etc.), underground obstacles (sprinklers, pipes, tree roots, etc.). Cautiously enter a new area. Be alert for hidden hazards.
8. Disengage power to cutter deck before backing up. Do not mow in reverse unless absolutely necessary and then only after observation of the entire area behind the mower. If you must mow in reverse, maintain a constant lookout to the rear of the machine and mow slowly.
9. DO NOT turn sharply. Use care when backing up.
10. Disengage power to cutter deck before crossing roads, walks or gravel drives.
11. Mow only in daylight or good artificial light.
12. NEVER raise the deck with the blades engaged.
13. Take all possible precautions when leaving the machine unattended, such as disengaging the mower, lowering the attachments, setting the parking brake, stopping the engine, and removing the key.
14. Disengage power to the attachments when transporting or when not in use.

15. The machine and attachments should be stopped and inspected for damage after striking a foreign object, and damage should be repaired before restarting and operating the machine.

 **CAUTION**

Do not touch the engine or the muffler while the engine is running or immediately after stopping. These areas may be hot enough to cause a burn.

 **DANGER**

DO NOT run the engine inside a building or a confined area without proper ventilation. Exhaust fumes are hazardous and contain carbon monoxide which can cause brain injury and death.

16. Keep hands and feet away from cutter blades and moving parts. Contact can injure.
17. Transport the mower using a heavy duty trailer or truck. Insure the trailer or truck has all of the necessary lighting and markings as required by laws, codes, and ordinances. Secure a trailer with a safety chain.
18. Be cautious when loading and unloading onto trailers or trucks. Use only a full width ramp. Ramp angle should be no more than 15 degrees. Back up the ramp and drive down forward.
19. When transporting the mower, make sure the park brake is engaged, the steering control levers are in the neutral position, the engine is off with the key removed, and the wheels have been blocked.
20. Tie the mower down securely using straps, chains, cable, or ropes. Both front and rear straps must be directed down and outward from machine.
21. Use care when approaching blind corners, shrubs, trees, or other objects that may obscure vision.
22. NEVER leave the machine running unattended.

2.5 ROLL-OVER PROTECTION SYSTEM

WARNING

The seat belt must be securely fastened during operation. Failure to do so could cause serious injury or loss of life.

This mower has been designed for good traction and stability under normal mowing conditions. However, caution must be used when traveling on slopes, especially when the grass is wet. Do not mow on wet grass. Wet grass reduces traction and steering control.

Any or all parts of the Roll-Over Protection System **MUST NOT** be removed. Failure to adhere to this guideline could result in injury or death.

The potential exposure of the seat belt to severe environmental conditions make it crucial to inspect the seat belt system regularly.

It is recommended that the seat belt be inspected on a daily basis for signs of damage. Any seat belt system that shows cuts, fraying, extreme or unusual wear, significant discoloration due to UV exposure, dirt or stiffness, abrasion to the seat belt webbing, or damage to the buckle, latch plate, hardware or any other obvious problem should be replaced immediately.

WARNING

Failure to properly inspect and maintain the seat belt can cause serious injury or loss of life.

1. Check the full length of the seat belt webbing for cuts, wear, fraying, dirt and stiffness. See Figure 2-1.
2. Check the seat belt webbing in areas exposed to ultra violet rays from the sun or extreme dust or dirt. If the original color of the webbing in these areas is extremely faded and/or is packed with dirt, the physical strength of this webbing may have deteriorated. If this condition exists, replace the seat belt system.
3. Check the buckle and latch for proper operation and determine if the latch plate is excessively worn, deformed, or if the buckle is damaged or cracked. See Figure 2-1.

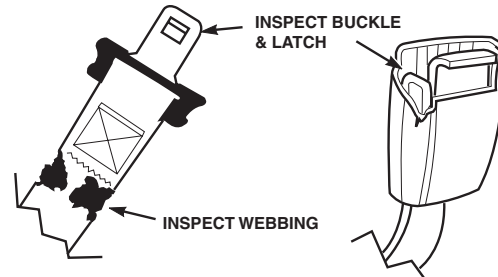

Figure 2-1. Seat Belt Inspection

WARNING

Reduce speed when turning, operating on slopes, slick or wet surfaces. Allow extra distance to stop.

Stay off of slopes too steep for safe operation. To check a slope, attempt to back up it (with the cutter deck down). If the machine can not back up the slope without the wheels slipping, do not operate the machine on this slope. Under no circumstances should the machine be operated on slopes greater than 15 degrees.

DO NOT mow near drop-offs, ditches or embankments. The machine could suddenly roll over if a wheel goes over the edge or if the edge caves in.

Operate the machine smoothly, no sudden turns, starts or stops on a slope.

NEVER tow on slopes. The weight of the towed equipment may cause loss of traction and loss of control.

DO NOT permit untrained personnel to operate the machine.

Be cautious when loading and unloading onto trailers or trucks.

Use only a full width ramp.

Ramp angle should be no more than 15 Degrees.

Back up the ramp and drive down forward.

Section 2

2.6 MAINTENANCE CONSIDERATIONS & STORAGE

1. Never make adjustments to the machine with the engine running unless specifically instructed to do so. If the engine is running, keep hands, feet, and clothing away from moving parts.
2. Disengage drives, lower implement, set parking brake, stop engine and remove key or disconnect spark plug wire to prevent accidental starting of the engine when servicing or adjusting the machine. Wait for all movement to stop before adjusting, cleaning or repairing.
3. Disconnect battery or remove spark plug wire before making any repairs. Disconnect the negative terminal first and the positive last. Reconnect the positive first and the negative last.
4. Keep all nuts, bolts and screws tight, to ensure the machine is in safe working condition. Check blade mounting bolts frequently to be sure they are tight.
5. Do not change the engine governor settings or overspeed the engine. See the engine operator's manual for information on engine settings.
6. To reduce fire hazard, keep the cutting units, drives, muffler and engine free of grass, leaves, excessive grease, oil and dirt.
7. Park the machine on level ground and engage the parking brake.
8. NEVER allow untrained personnel to service the machine.
9. Use care when checking blades. Use a Blade Buddy, wrap the blade(s) or wear gloves and USE CAUTION when servicing blades. Only replace blades. NEVER straighten or weld blades.
10. Keep all parts in good working condition. Replace all worn or damaged decals.
11. Use jack stands to support components when required.
12. Carefully release pressure from components with stored energy.

WARNING

Hydraulic fluid is under high pressure. Keep body and hands away from pinholes or nozzles that eject hydraulic fluid under high pressure. If you need service on your hydraulic system, please see your authorized Scag dealer. If hydraulic fluid is injected into the skin, it must be surgically removed within a few hours by a doctor or gangrene may result.

13. Let the engine cool before storing.
14. DO NOT store the machine near an open flame.
15. Shut off fuel while storing or transporting.
16. DO NOT store fuel near flames or drain indoors.
17. Charge batteries in an open, well ventilated area, away from spark and flames. Unplug charger before connecting or disconnecting from battery. Wear protective clothing and use insulated tools.

2.7 USING A SPARK ARRESTOR

The engine in this machine is not equipped with a spark arrester muffler. It is in violation of California Public Resource Code Section 4442 to use or operate this engine on or near any forest covered, brush covered or grass covered land unless the exhaust system is equipped with a spark arrester meeting any applicable local or state laws. Other states or federal areas may have similar laws. Check with your state or local authorities for regulations pertaining to these requirements.

SPECIFICATIONS**3.1 ENGINE**

General Type	Heavy Duty Industrial/Commercial Gasoline
Brand	Briggs & Stratton, Kawasaki
Horsepower:	
(Scag Model SFZ36-17KA)	17 HP (Spec.#FH541V-AW00-R)
(Scag Model SFZ48-19KA, SFZ52-19KA)	19 HP (Spec.# FH580V-AW00-R)
(Scag Model SFZ36-20BS)	20 HP (Spec# 40G7770117B1)
(Scag Model SFZ48-26BS, SFZ52-26BS)	26 HP (Spec.# 44P7770117E1)
(Scag Model SFZ61-28BS)	28 HP (Spec# 49M777930308)
Type	4 Cycle Gasoline, Twin Cylinder, Vertical Shaft
Cylinders.....	2 with Cast Iron Sleeves
Governor.....	Mechanical Type with Variable Speed Control Set At 3600 RPM
Idle Speed:	
Briggs & Stratton	1750 RPM
Kawasaki	1550 RPM
Fuel Pump	Integral Fuel Pump with In-Line Fuel Filter
Fuel.....	Non-Leaded Gasoline with a Minimum Octane Rating of 87
Oil Pump.....	Positive Displacement Gerotor™
Starter:.....	Electric Starting with Bendix Shift Starter
Belts.....	Kevlar cord. Self-adjusting, Self-tightening

3.2 ELECTRICAL

Battery	12 Volt
Charging System	Alternator
Charging Output:	
Briggs & Stratton	12 Volt, 16 Amp
Kawasaki	12 Volt, 13 Amp
System Polarity.....	Negative Ground
Starter.....	12 Volt Electric Ring Gear Type, Key Operated
Interlock Switches.....	Seat, Neutral Control, Mower Engagement (BBC), Parking Brake
Instrument Panel	Key Switch, Throttle Lever, Manual Choke, PTO Switch
Fuses.....	Two (2) 20 Amp

3.3 TRACTOR

Drive System	Hydraulic Drive with Two Hydro-Gear™ Integrated Zero-Turn Axles
Scag Model (SFZ36, SFZ48, SFZ52).....	Hydro-Gear™ ZT-3100
Scag Model (SFZ61)	Hydro-Gear™ ZT-3400
Steering/Travel Control	Twin Lever Fingertip Steering Control with Individual Control to Each Wheel with Gas Spring Dampers
Parking Brake	Lever Actuated Linkage to Brakes on Both Drive Wheel Axles
Wheels:	
(2) Front Caster	11 X 4.5-5 Two-Ply
(2) Drive - (36" Deck).....	18 X 7-8 Four-Ply Pneumatic Tubeless, Radius Edge
(2) Drive - (48"-52" Deck)	20 X 10-8 Four-Ply Pneumatic Tubeless, Radius Edge
(2) Drive - (61" Deck).....	20 x 10.5-8 Four-Ply Pneumatic Tubeless, Radius Edge
Tire Pressure:	
Front Caster.....	25 PSI
Drive	8 PSI
Fuel Tank	Single 6.5-Gallon Seamless Polyethylene Tanks with Large Opening and Fuel Cap
Seat	Padded, Thick Cushion with Extra Spring Support

Travel Speed:

- Forward 0-8 MPH
- Reverse 0-5 MPH

-NOTE- The machine will travel at 8 mph for transport purposes. For best cutting performance the forward travel speed should be adjusted depending upon the cutting conditions.

3.4 CUTTER DECK

Type Floating, Adjustable, Anti-Scalping, Hybrid Design Combines Out-Front and Belly-Mount Designs
 Construction 10-Gauge top with 11-Gauge reinforcement throughout the spindle area, 7-Gauge skirt for strength and longevity

True Cutting Width:

- 36 36" (91.44 cm)
- 48 48" (122.0 cm)
- 52 52" (132.0 cm)
- 61 61" (154.94 cm)

Cutting Height Adjustment.....Foot-Operated Lever Adjustment from Operator's Seat, 1.00" to 4.5" in 1/4"increments

Cutter Blades..... 0.197 in. Thick, Milled Edge, Wear Resistant Marbain™

Blade Engagement..... Electric Blade Engagement Clutch with Control Panel Switch
 Connected to the Cutter Deck through a Belt.

Discharge Opening..... Extra Wide Discharge Opening with Spring-Loaded Discharge Chute

Discharge Chute.....Black, Polypropylene (Plastic), Flexible

Spindles..... Heavy-Duty Spindle Shaft, Cast Aluminum Housing, Sealed Ball Bearing, Maintenance-Free

Spindle Pulleys..... Split Steel

Cutter Deck Belts..... B-section with Kevlar Cord. Self-Adjusting, Self-Tightening

Electric Clutch Type Ogura Heavy Duty PTO Clutch Brake

3.5 HYDRAULIC SYSTEM

Hydraulic Oil Filter 40 Micron Spin-on Element Type

Hydraulic Expansion Reservoir Nylon

3.6 WEIGHTS AND DIMENSIONS

	36	48/52	61
Length.....	73"	73"	79"
Tracking Width	35.5"	47.5"	47.5"
Overall Width w/chute down	48.5"	60.5" / 64.5"	73.5"
Overall Width w/chute up.....	37"	49" / 53"	62"
Overall Height.....	60"	60"	60"
Operating Weight.....	690#	775# / 785#	810#

PRODUCTIVITY.....

	36	48/52	61
--	-----------	--------------	-----------

Cutting Width	36"	48"/52"	61"
---------------------	-----	---------	-----

Acres Per Day.....	14	18.6/20.2	23.7
--------------------	----	-----------	------

The preceding chart will aid you in determining how many acres your Scag mower will cut per day. The chart is an estimate based on 8 hours per day cutting time at 6 MPH with a 20% allowance for overlap and turns.

OPERATING INSTRUCTIONS

CAUTION

Do not attempt to operate this mower unless you have read this manual. Learn the location and purpose of all controls and instruments before you operate this mower.

4.1 CONTROLS AND INSTRUMENT IDENTIFICATION

Before operating the mower, familiarize yourself with all mower and engine controls. Knowing the location, function and operation of these controls is important for safe and efficient operation of the mower.

1. **Ignition Switch (Figure 4-1).** The ignition switch is used to start the engine and has three positions; OFF, ON, and START.
2. **Mower Deck Switch (Figure 4-1).** Used to engage and disengage the mower drive system. Pulling up on the switch will engage the deck drive. Pushing down on the switch will disengage the deck drive.
3. **Engine Choke Control (Figure 4-1).** Used to start a cold engine.
4. **Engine Throttle Control (Figure 4-1).** Used to control the engine speed. Pushing the lever forward increases engine speed. Pulling the lever back decreases engine speed. Full back position is the IDLE position. Full forward is the cutting position.
5. **Fuel Gauge (Figure 4-1).** Indicates the amount of fuel in the fuel tank.

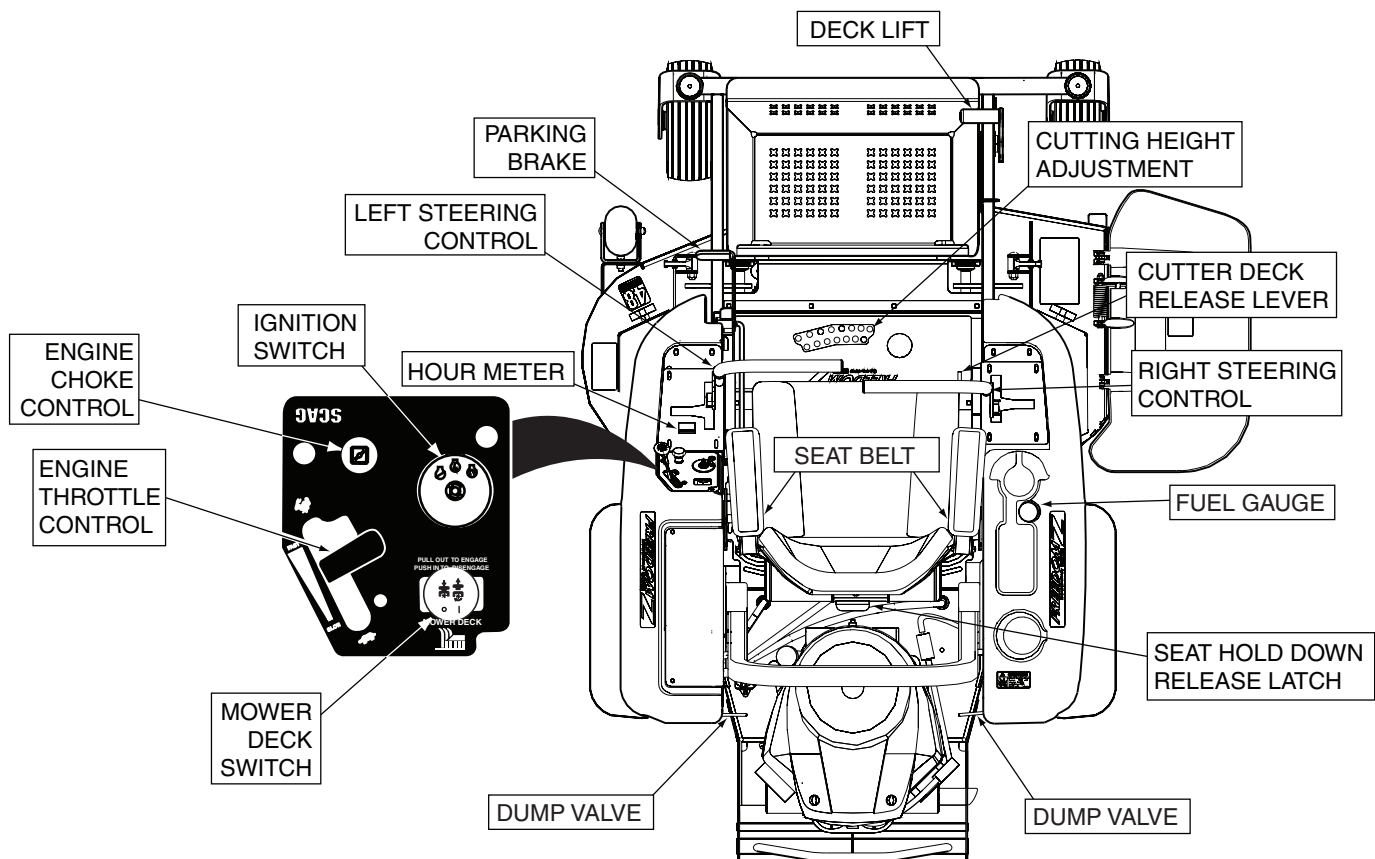

Figure 4-1. Controls and Instruments

6. **Hourmeter (Figure 4-1).** Indicates the number of hours the engine has been operated. It operates whenever the ignition key switch is in the ON position. Has preset maintenance reminders for engine and hydraulic system oil changes. Will start flashing scheduled maintenance 2 hours before preset time and continue flashing until 2 hours after. Automatically resets.
7. **Fuse Holders (Figure 4-1).** Two 20-amp fuses protect the mower's electrical system. To replace fuses, pull fuse out of the socket and install a new fuse.
8. **Left Steering Control (Figure 4-1).** Used to control the mower's left wheel when traveling forward or reverse.
9. **Right Steering Control (Figure 4-1).** Used to control the mower's right wheel when traveling forward or reverse.
10. **Parking Brake Control (Figure 4-1).** Used to engage and disengage the parking brakes. Pull the lever back to engage the parking brakes. Push the lever forward to disengage the parking brakes.
11. **Dump Valve Control Levers (Figure 4-2).** Located on the left and right side of the bumper, used to "free-wheel" the mower. Rotating the levers forward into the notch (towards the front of the mower) allows the unit to move under hydraulic power. Rotating the levers backward to the notch (towards the rear of the mower) allows the mower to be moved by hand (free-wheeling).

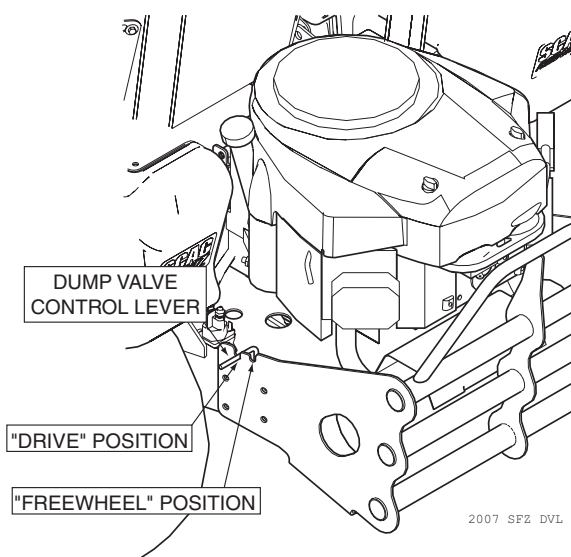

Figure 4-2. Dump Valve Control

12. **Deck Lift Foot Lever (Figure 4-1).** Used to raise and lower the cutter deck.
13. **Cutting Height Adjustment (Figure 4-1).** Used to set the cutter deck at the desired cutting height.
14. **Deck Release Lever (Figure 4-1).** Used to lock the cutter deck in the transport position. Push the foot pedal forward and pull back on the release lever to release the cutter deck for normal mowing.
15. **Seat Belt (Figure 4-1).** Used to secure the operator. Seat belt must be worn at all times during operation.
16. **Seat Hold Down Release Latch (Figure 4-1).** Located behind the seat. Used to secure the seat in the operator's position. Release the latch to gain access under the seat.

4.2 SAFETY INTERLOCK SYSTEM

The mower is equipped with a safety interlock system that prevents the engine from starting unless the deck drive is disengaged, the steering control levers are in the neutral position and the operator is in the seat. The interlock system shuts off the engine if the operator leaves the seat with the steering control levers not in the neutral position and/or the cutter blades engaged and the parking brake not engaged.

⚠ WARNING

Never operate the mower with the interlock system disconnected or malfunctioning. Do not disengage or bypass any switch; injury to yourself and others or property damage could result.

4.3 INITIAL RUN-IN PROCEDURES

FIRST DAY OF USE OR APPROXIMATELY 20 HOURS

1. Check all belts for proper alignment and wear at 2, 4 and 8 hours.
2. Change the engine oil and oil filter after the first 20 hours of operation. (See Section 7.4.)
3. Check hydraulic oil level in reservoir. (See Section 7.3.)
4. Check for loose hardware. Tighten as needed.

Section 4

5. Check interlock system for proper operation. (See Section 4.2.)
6. Check tire pressure. Adjust pressure if necessary. (See Section 7.10.)

4.4 STARTING THE ENGINE

CAUTION

DO NOT USE STARTING FLUIDS. Use of starting fluids in the air intake system may be potentially explosive or cause a “runaway” engine condition that could result in engine damage and/or personal injury.

1. Be sure the fuel shutoff valve, located behind the operator's seat, is completely open.
2. Sit in the operator's seat, fasten seat belt and place the steering control levers in the neutral position.
3. Engage the parking brake.
4. Place the PTO switch in the disengaged position.
5. If the engine is cold, choke the engine as needed.
6. Move the engine throttle control to about half engine speed.
7. Turn the ignition key to the START position and release the key as soon as the engine starts. Do not hold the key in the START position for more than 15 seconds at a time. Allow at least 60 seconds between each cranking attempt to prevent overheating of the starter motor. Prolonged cranking can damage the starter motor and shorten battery life.
8. Allow engine to warm before operating the mower.

4.5 GROUND TRAVEL AND STEERING

- IMPORTANT -

If you are not familiar with the operation of a machine with lever steering and/or hydrostatic transmissions, the steering and ground speed operations should be learned and practiced in an open area, away from buildings, fences, or obstructions.

Learn the operation on flat ground before operating on slopes.

Start practicing with a slow engine speed and slow forward travel.

Learn to feather the steering controls to obtain a smooth operating action.

Practice operating the mower until you are comfortable with the controls before proceeding to mow.

FORWARD TRAVEL

To travel forward with the mower, disengage the parking brake, pull levers inward out of the neutral lock position and slowly push the steering control levers forward an equal distance. The further the steering control levers are pushed forward the greater the forward speed will be. To increase the speed, push the steering control levers further forward and to decrease the speed, pull the steering control levers back.

To stop the forward travel, pull the steering control levers back to the neutral position.

To steer the mower left while traveling forward, pull the left steering lever back. The further the lever is pulled back, the quicker the mower will turn left.

To steer the mower right while traveling forward, pull the right steering control lever back. The further the lever is pulled back, the quicker the mower will turn right.

- NOTE -

Smooth operation of the steering levers will produce smooth mower operation. While learning the operation of the steering controls, keep the travel speed low.

- IMPORTANT -

Do not travel forward over a curb. The mower will hang up on the curb. Raise the deck and travel backwards over the curb at a 45 degree angle. (See Figure 4-1 item 12 for cutter deck raising description.)

REVERSE TRAVEL

CAUTION

Disengage power to the mower before backing up. Do not mow in reverse unless absolutely necessary and then only after observation of the entire area behind the mower.

CAUTION

Before backing up, observe the rear for persons and obstructions. Clear the area before backing up. Possible injury or property damage could occur.

To travel in reverse, pull levers inward out of the neutral lock position and pull both handles back. Keep the travel speed low while traveling in reverse.

- NOTE -

The mower may not travel straight in reverse. Slight adjustments may need to be made using the steering controls.

To steer left while traveling in reverse, allow the left steering control lever to move forward. The further the control is allowed to move forward, the quicker the mower will turn left.

To steer right while traveling in reverse, allow the right steering control lever to move forward. The further the control is allowed to move forward, the quicker the mower will turn right.

To stop the reverse travel, allow the steering control levers to return to the neutral position. If the mower is to be parked, place the handles in the neutral lock position and engage the parking brake.

4.6 ENGAGING THE DECK DRIVE (CUTTER BLADES)

1. Set the throttle at about 3/4 speed. Do not attempt to engage the deck drive at high speed as this shortens the electric clutch life — use only moderate engine speed when engaging the deck drive.
2. Engage the deck drive by pulling out on the yellow switch, located on the instrument panel, to the engage position. See Figure 4-3.

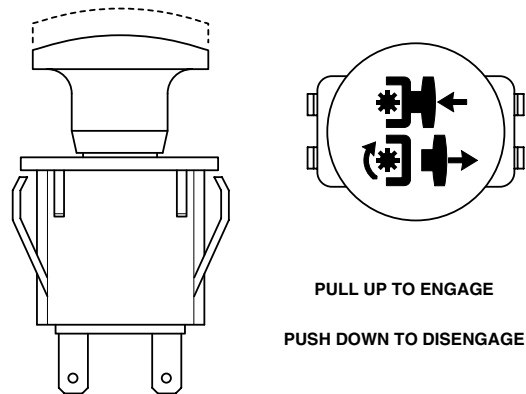

390S0138

Figure 4-3. Cutter Engage Switch

- NOTE -

A squealing noise may be heard when engaging or disengaging the deck drive. It is caused by the electric clutch plates meshing as the mower comes up to speed. This is normal.

3. To disengage the deck drive, push the switch in to the disengage position.
4. Always operate the engine at full throttle to properly maintain cutting speed. If the engine starts to lug down, reduce the forward speed and allow the engine to operate at maximum RPM.

Section 4

4.7 HILLSIDE OPERATION

WARNING

DO NOT operate on steep slopes. To check a slope, attempt to back up it (with the cutter deck down). If the machine can back up the slope without the wheels slipping, reduce speed and use extreme caution. Under no circumstances should the machine be operated on slopes greater than 15 degrees. ALWAYS FOLLOW OSHA APPROVED OPERATION.

1. This mower has been designed for good traction and stability under normal mowing conditions. However, caution must be used when traveling on slopes, especially when the grass is wet. Wet grass reduces traction and steering control. The Roll-Over Protection System is standard equipment for this machine. See Section 2.5, page 6 of this manual for further details.
2. Some areas may need to be mowed with a walk-behind mower or string trimmer
3. To prevent tipping or loss of control, do not start or stop suddenly, avoid unnecessary turns and travel at reduced speed. If tires lose traction, disengage blades and proceed slowly off the slope.
4. Avoid sudden starts when mowing uphill. Sudden starts may cause the machine to tip backwards.
5. Loss of traction may occur when traveling down hill. Weight transfers to the front of the machine and may cause the drive wheels to slip causing loss of braking or steering.
6. Keep tires properly inflated.
7. Use caution when operating the mower on an incline with the optional grass catcher installed.

4.8 PARKING THE MOWER

1. Park the machine on a flat, level surface only. Do not park the machine on an incline.
2. Place the steering control levers in the neutral position.
3. Disengage the cutter blades.
4. Slow the engine to idle speed.
5. Engage the parking brake.

6. Turn the ignition key to the OFF position and remove the key.

4.9 AFTER OPERATION

1. Wash the entire mower after each use. Do not use high pressure spray or direct the spray onto electrical components.

- IMPORTANT -

Do not wash a hot or running engine. Cold water will damage the engine. Use compressed air to clean the engine if it is hot.

2. Keep the entire mower clean to inhibit serious heat damage to the engine or hydraulic oil circuit.
3. Check the drive belts for proper alignment and any signs of wear. Correct and adjust if necessary.

DANGER

To avoid injury from burns, allow the mower to cool before removing the fuel tank cap and refueling.

4. After the mower has cooled down, fill the fuel tank with fresh, clean fuel at the end of every day of operation. See Engine Owner's Manual for proper octane requirements.
5. Check the tire pressure. Adjust pressure if necessary.

4.10 REMOVING CLOGGED MATERIAL

DANGER

ROTATING BLADES

NEVER PUT YOUR HANDS INTO THE DISCHARGE CHUTE FOR ANY REASON!

Shut off the engine and remove the key and only then use a stick or similar object to remove material if clogging has occurred.

1. If the discharge chute becomes clogged, shut off the engine and remove the ignition key. Using a stick or similar item, dislodge the clogged material. Then resume normal mowing.

4.11 MOVING MOWER WITH ENGINE STOPPED

To “free-wheel” or move the mower around without the engine running, place the dump valve levers in the FREE-WHEEL position. See Figure 4-2, page 13. Disengage the parking brake and move the mower by hand. When the machine is in the desired position, engage the parking brake and place the dump valve levers in the DRIVE position. The dump valve levers must be returned to the DRIVE position to drive the mower.

4.12 RECOMMENDATIONS FOR MOWING

1. Do not mow with dull blades. A dull blade will tear grass, resulting in poor lawn appearance and reduced mowing power.

WARNING

DO NOT operate without Discharge Chute, Mulching Kit, or entire Grass Catcher properly installed.

2. The discharge chute must not be removed and must be kept in the lowest position to deflect grass clippings and thrown objects downward. Direct the side discharge away from sidewalks or streets to minimize cleanup of clippings. When mowing close to obstacles, direct the discharge away from the obstacles to reduce the chance of property damage by thrown objects.
3. Cut grass when it is dry and not too tall. Do not cut grass too short (cut off 1/3 or less of existing grass for best appearance). Mow frequently.
4. Keep mower and discharge chute clean.
5. When mowing wet or tall grass, mow the grass twice. Raise the mower to the highest setting for the first pass and then make a second pass to the desired height.
6. Use a slow travel speed for trimming purposes.

7. Operate the engine at full throttle for best cutting. Mowing with a lower RPM causes the mower to tear the grass. The engine is designed to be operated at full speed.
8. Use the alternate stripe pattern for best lawn appearance. Vary the direction of the stripe each time the grass is mowed to avoid wear patterns in the grass.

4.13 ADJUSTING CUTTING HEIGHT

The mower deck can be adjusted from a height of 1 inch to 4-1/2 inches at 1/4-inch intervals. To adjust the cutting height:

WARNING

DO NOT adjust the cutting height with the mower blades rotating. Disengage the power to the cutter blades and then adjust cutting height.

1. Disengage the power to the cutter blades.
2. Push the cutting height adjustment foot pedal all the way forward using your right foot until it locks in place. See Figure 4-4.

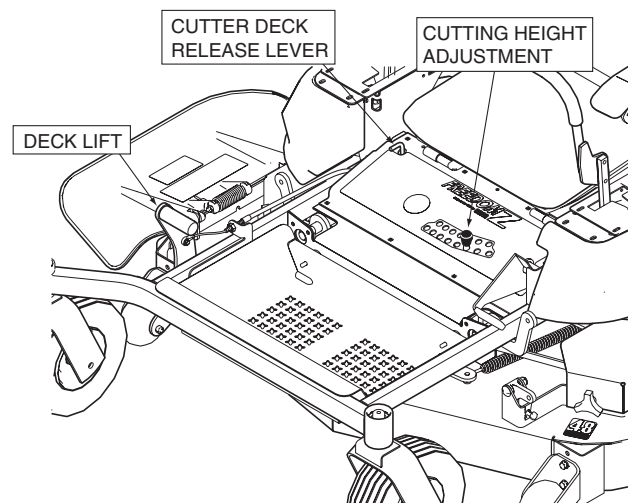

Figure 4-4. Adjusting Cutting Height

Section 4

3. Insert the pin into the cutting height index at the desired cutting height. Push forward on the deck lift foot lever, hold in place and lift up on the deck release lever. See Figure 4-4. Slowly release the foot pedal. A deck height decal is located on the cutting height index as an aid in adjusting the deck to the desired height. See Figure 4-4.

4.14 TOWING (OPTIONAL HITCH ACCESSORY) (NOT AVAILABLE FOR SFZ36)

1. NEVER allow children or others in or on towed equipment.
2. Tow only with a machine that has a hitch designed for towing. Do not attach towed equipment except at the hitch point.
3. Follow manufacturer's recommendations for weight limit for towed equipment. 250/lbs. maximum towing weight.
4. NEVER TOW ON SLOPES. The weight of the towed equipment may cause loss of traction and loss of control.
5. Travel slowly and allow extra distance to stop.
6. Zero-turning with a trailer attached could cause damage to the trailer or mower.

TROUBLESHOOTING CUTTING CONDITIONS

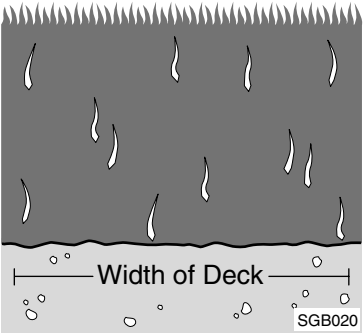
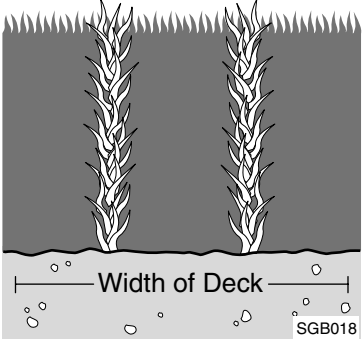
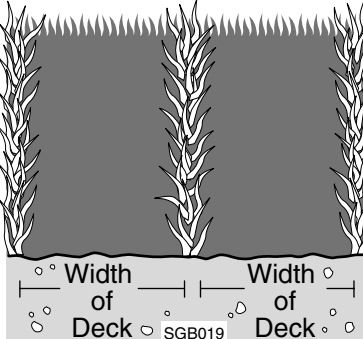
CONDITION	CAUSE	CURE
<p>STRINGERS - OCCASIONAL BLADES OF UNCUT GRASS</p> 	Low engine RPM	Run engine at full RPM
	Ground speed too fast	Slow speed to adjust for conditions
	Wet grass	Cut grass after it has dried out
	Dull blades, incorrect sharpening	Sharpen blades
	Deck plugged, grass accumulation	Clean underside of deck
	Belts slipping	Adjust belt tension
<p>STREAKING - STRIPS OF UNCUT GRASS IN CUTTING PATH</p> 	Dull, worn blades	Sharpen blades
	Incorrect blade sharpening	Sharpen blades
	Low engine RPM	Run engine at full RPM
	Belt slipping	Adjust belt tension
	Deck plugged, grass accumulation	Clean underside of deck
	Ground speed too fast	Slow speed to adjust for conditions
	Wet grass	Cut grass after it has dried out
	Bent blades	Replace blades
<p>STREAKING - STRIPS OF UNCUT GRASS BETWEEN CUTTING PATHS</p> 	Not enough overlapping between rows	Increase the overlap of each pass

TROUBLESHOOTING CUTTING CONDITIONS (CONT'D)

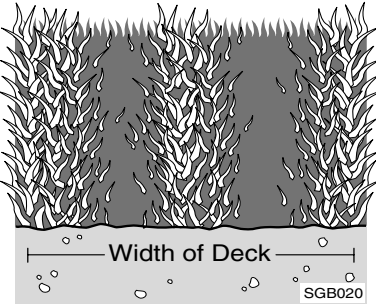
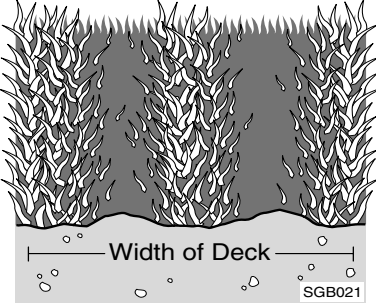
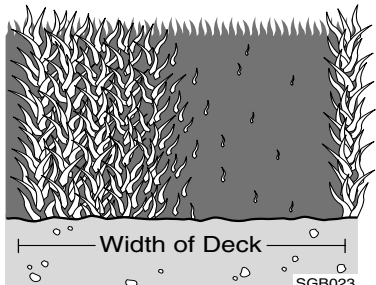
CONDITION	CAUSE	CURE
<p>UNEVEN CUT ON FLAT GROUND - WAVY HIGH-LOW APPEARANCE, SCALLOPED CUT, OR ROUGH CONTOUR</p>  <p>Width of Deck SGB020</p>	Lift worn from blade	Replace blade
	Blade upside down	Mount with cutting edge toward ground
	Deck plugged, grass accumulation	Clean underside of deck
	Too much blade angle (deck pitch)	Adjust pitch and level
	Deck mounted improperly	See your authorized SCAG dealer
	Bent spindle area	See your authorized SCAG dealer
	Dull blade	Sharpen blade
<p>UNEVEN CUT ON UNEVEN GROUND-WAVY APPEARANCE, HIGH-LOW SCALLOPED CUT, OR ROUGH CONTOUR</p>  <p>Width of Deck SGB021</p>	Uneven ground	May need to reduce ground speed, raise cutting height, and/or change direction of cut
<p>SLOPING RIDGE ACROSS WIDTH OF CUTTING PATH</p>  <p>Width of Deck SGB023</p>	Tire pressures not equal	Check and adjust tire pressure
	Wheels uneven	Check and adjust tire pressure
	Deck mounted incorrectly	See your authorized SCAG dealer
	Deck not level side-to-side	Check for level and correct

TROUBLESHOOTING CUTTING CONDITIONS (CONT'D)

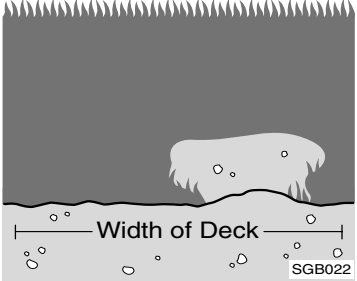
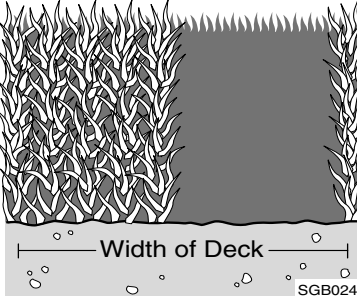
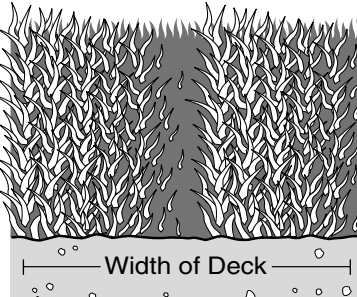
CONDITION	CAUSE	CURE
<p>SCALPING - BLADES HITTING DIRT OR CUTTING VERY CLOSE TO THE GROUND</p>  <p style="text-align: right; font-size: small;">SGB022</p>	Low tire pressures	Check and adjust pressures
	Ground speed too fast	Slow speed to adjust for conditions
	Cutting too low	May need to reduce ground speed, raise cutting height, change direction of cut, and/or change pitch and level
	Rough terrain	May need to reduce ground speed, raise cutting height, and/or change direction of cut
	Ground speed too fast	Slow speed to adjust for conditions
	Wet grass	Cut grass after it has dried out
<p>STEP CUT - RIDGE IN CENTER OF CUTTING PATH</p>  <p style="text-align: right; font-size: small;">SGB024</p>	Blades not mounted evenly	Adjust pitch and level
	Bent blade	Replace blade
	Internal spindle failure	See your authorized SCAG dealer
	Mounting of spindle incorrect	See your authorized SCAG dealer
<p>SLOPE CUT - SLOPING RIDGES ACROSS WIDTH OF CUTTING PATH</p>  <p style="text-align: right; font-size: small;">SGB025</p>	Bent spindle mounting area	See your authorized SCAG dealer
	Internal spindle failure	See your authorized SCAG dealer
	Bent deck housing	See your authorized SCAG dealer

ADJUSTMENTS

6.1 PARKING BRAKE ADJUSTMENT

WARNING

Do not operate the mower if the parking brake is not operable. Possible severe injury could result.

The parking brake linkage should be adjusted whenever the parking brake lever is placed in the “ENGAGE” position and the parking brake will not prevent the mower from moving. If the following procedures do not allow you to engage the parking brake properly, contact your Scag dealer for further brake adjustments.

1. Park the machine on a flat surface and block the caster wheels to prevent the machine from moving. Remove the ignition key.
2. Disengage the parking brake. See Figure 6-1.
3. Release the seat hold down latch and tilt the seat forward to gain access to the brake control linkage.
4. Remove the cotter pin securing the pivot to the brake control linkage. See Figure 6-2.
5. Push down on the brake control rod to disengage the parking brake and adjust the pivot until it meets the mounting hole. Insert the pivot into the brake control linkage and secure with the cotter pin.
6. Repeat steps 4 and 5 on the other side of the machine.
7. Test the parking brake.

- NOTE -

If this procedure does not achieve proper brake adjustment, please contact your authorized Scag dealer.

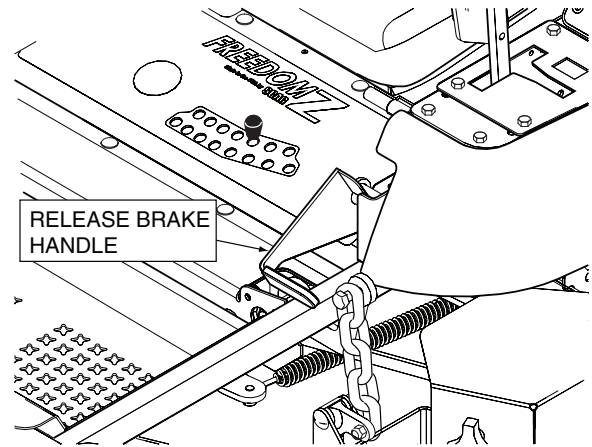

Figure 6-1. Brake Adjustment

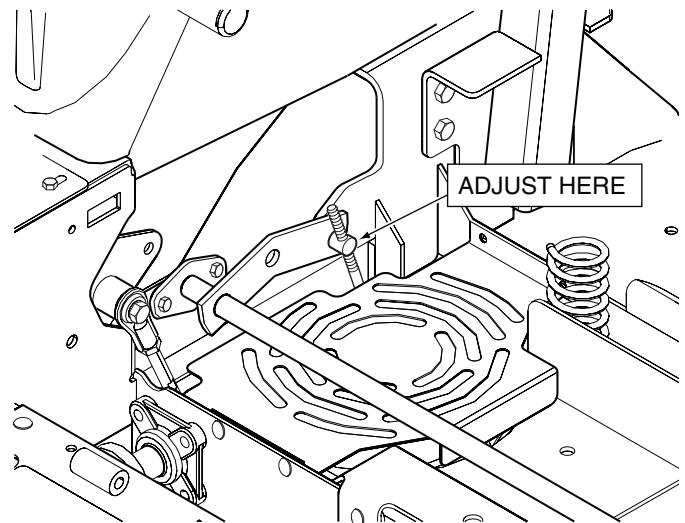

Figure 6-2. Brake Rod Adjustment

6.2 TRAVEL ADJUSTMENTS

Neutral or tracking adjustments will need to be made if:

- A. The steering control levers are in the neutral position and the machine creeps forward or backward. (See Neutral Adjustment).
- B. The steering control levers are in the full forward position and the mower pulls to one side or the other when traveling in a forward direction. (Tracking Adjustment, See Page 24).

NEUTRAL ADJUSTMENT

1. Be sure the dump valve levers are in the run position and the steering control levers are in the neutral lock position.
2. With an operator in the seat, start the engine and disengage the parking brake.

MOVE STEERING LEVER OUT TO THE NEUTRAL POSITION

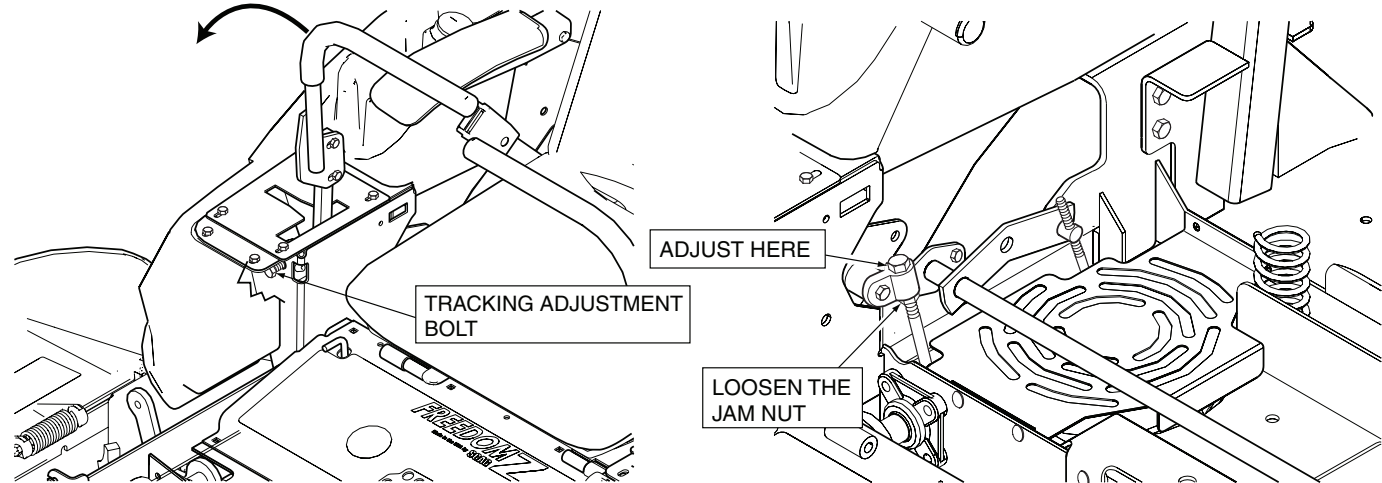

Figure 6-3. Steering Control Rod Adjustment

3. Run the engine at full operating speed and check if the machine creeps forward or backwards.
4. Adjust the RH wheel by loosening the jam nuts on the steering control rod and turning the adjustment nut until the drive wheel turns in the forward direction. Turn the adjustment nut back until the drive wheel stops moving. Turn the adjustment nut an additional 1/2 turn. See Figure 6-3.
5. Tighten the jam nuts and repeat for the LH wheel. See Figure 6-3.
6. Actuate the steering control levers forward and reverse several times and return them to the neutral position.
7. Check that the drive wheels remained in neutral and readjust if necessary.

Section 6**TRACKING ADJUSTMENT**** CAUTION**

Stop the engine and remove the key from the ignition before making any adjustments. Wait for all moving parts to come to a complete stop before beginning work.

 CAUTION

The engine and drive unit can get hot during operation causing burn injuries. Allow engine and drive components to cool before making any adjustments.

- NOTE -

Before proceeding with this adjustment, be sure that the caster wheels turn plus pivot freely and that the tire pressure in the drive wheels is correct. If the tire pressure is not correct, the machine will pull to the side with the lower pressure.

1. If at full speed the mower pulls right, it is an indication that the left wheel is turning faster than the right wheel. To adjust this condition, proceed as follows:
 - A. Stop the machine and place the steering control levers in the neutral position. Turn the tracking adjustment bolt for the LH pump inward (clockwise). This will cause the control rod to stroke the LH pump less, slowing down the LH wheel. See Figure 6-3.
2. If at full speed the mower pulls left, it is an indication that the right wheel is turning faster than the left wheel. To adjust this condition, proceed as follows:
 - A. Stop the machine and place the steering control levers in the neutral position. Turn the tracking adjustment bolt for the RH pump inward (clockwise). This will cause the control rod to stroke the RH pump less, slowing down the RH wheel. See Figure 6-3.

- NOTE -

If after making the adjustment as outlined do not correct the tracking or neutral, contact your local Authorized Scag Power Equipment Dealer.

6.3 THROTTLE CONTROL AND CHOKE ADJUSTMENTS

These adjustments must be performed by your Authorized Scag Power Equipment Dealer to ensure proper and efficient running of the engine. Should either need adjustment, contact your authorized Scag service center.

6.4 BELT ADJUSTMENT** WARNING**

Before removing any guards, shut the engine off and remove the ignition key.

All drive belts are spring loaded and self-tensioning, however after the first 2, 4, 8 and 10 hours of operation, the belts should be checked for proper alignment and wear. Thereafter, check the belts after every 40 hours of operation or weekly, whichever occurs first.

6.5 BELT ALIGNMENT

Belt alignment is important for proper performance of your Scag mower. If you experience frequent belt wear or breakage, see your authorized Scag service center for belt adjustment.

6.6 CUTTER DECK ADJUSTMENTS

Cutter deck level, pitch and height are set at the factory. However, if these adjustments should ever need to be made, the following procedures will aid in obtaining the proper cutter deck adjustment.

- NOTE -

Before proceeding with the cutter deck adjustments, be sure that all tires are properly inflated.

CUTTER DECK LEVEL

The cutter deck should be level from side-to-side for proper cutting performance. To check for level, be sure that the mower is on a flat, level surface, the tires are properly inflated and the cutter deck is set at the most common cutting height that you will use. On the RH side of the machine, check the distance from the top of the cutter deck to the floor. Next check the distance from the top of the cutter deck to the floor on the LH side of the machine. Both measurements should be the same. If the two measurements are different, the cutter deck level must be adjusted as follows:

1. If the cutter deck is lower on one side, loosen the elastic stop nuts securing the deck level links on the front and rear of the lower side. See Figure 6-4.

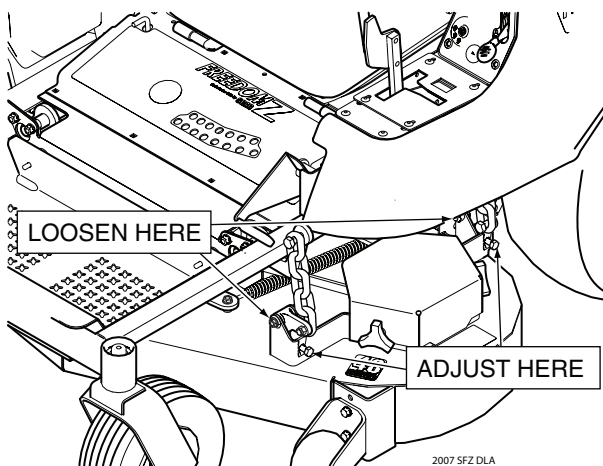

Figure 6-4. Cutter Deck Level Adjustment

2. Turn the adjustment bolts on the front and rear deck level links clockwise until the cutter deck is level between both sides. See Figure 6-4
3. Tighten the two (2) elastic stop nuts to secure the cutter deck in the proper position.

CUTTER DECK PITCH

The pitch of the cutter deck should be equal between the front and rear of the cutter deck for proper cutting performance. To check for proper deck pitch, be sure that the mower is on a flat, level surface and the tires are properly inflated.

Check the distance from the top of the cutter deck to the floor at the rear RH side of the cutter deck directly behind the cutter deck hanging chains. Next check the distance from the top of the cutter deck to the floor at the front RH side of the cutter deck directly in front of the cutter deck hanging chains. The measurement at the front of the cutter deck should be the same as the rear of the deck. Make these measurements at the LH side of the cutter deck also. If the measurement at the front of the deck is not the same, the cutter deck pitch must be adjusted as follows:

1. Loosen the elastic stop nuts securing the deck level links on the front of the cutter deck on both sides. See Figure 6-5 and 6-6.

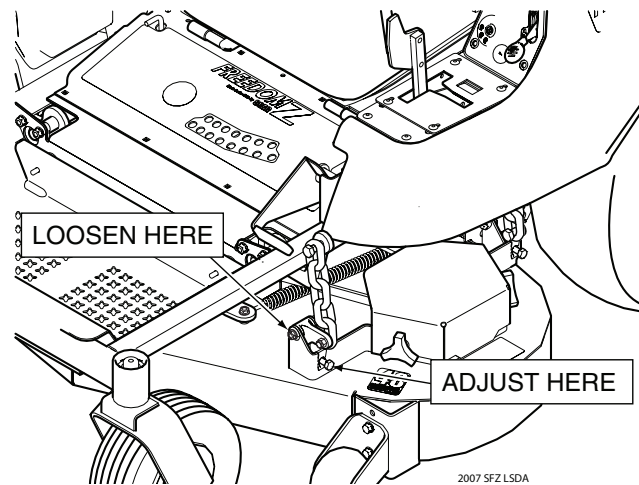

Figure 6-5. Cutter Deck Pitch Adjustment

2. Turn the adjustment bolts on both sides either clockwise to raise or counter-clockwise to lower the front of the cutter deck until the measurements are equal. Tighten the elastic stop nuts.

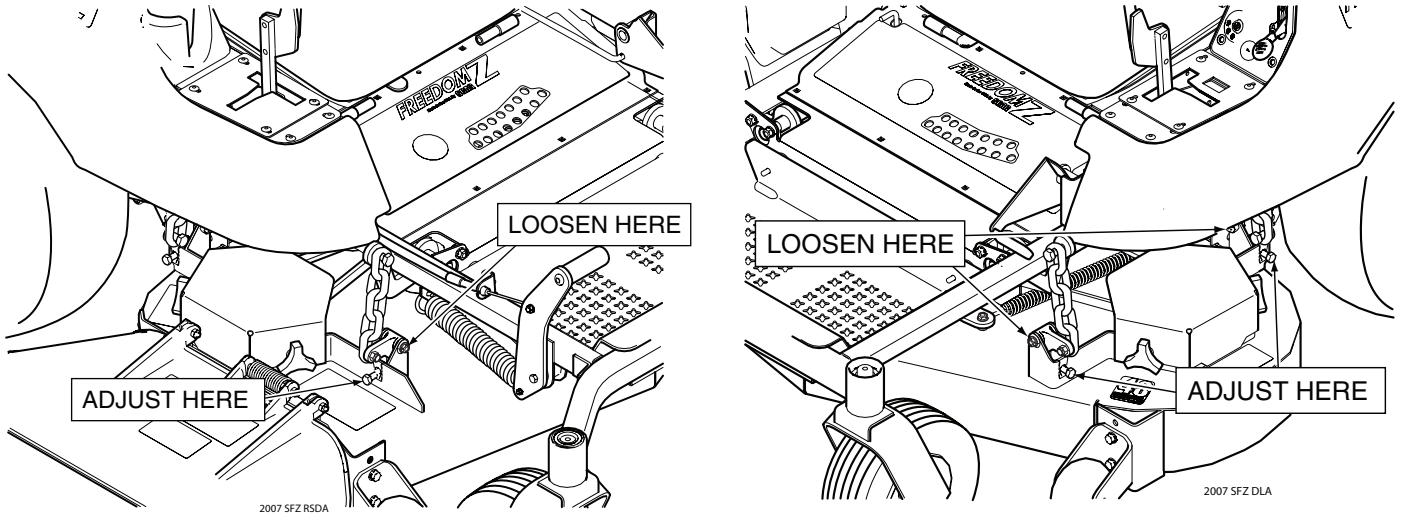

Figure 6-6. Cutter Deck Pitch Adjustment

- NOTE -

To prevent the cutter deck from teetering, all four (4) cutter deck hanging chains must have tension on them. If all four chains do not have tension on them and the deck teeters, you must readjust the cutter deck as outlined in the procedures above. All measurements should be taken from the top edge of the deck as the deck has an uneven bottom edge.

CUTTER DECK HEIGHT

The cutter deck height adjustment is made to ensure that the cutter deck is cutting at the height indicated on the cutting height index gauge. To check for proper deck height, be sure that the mower is on a flat, level surface and the tires are properly inflated.

1. Place the cutter deck in the 3" cutting position. Push on the cutter deck foot pedal and pull up on the cutter deck release lever to lower the cutter deck.
2. Check the measurement from the floor to the cutter blade tip. If the measurement is not 3", an adjustment can be made using the deck level links
3. Loosen the elastic stop nuts securing the deck level links on both sides of the cutter deck. See Figure 6-7.

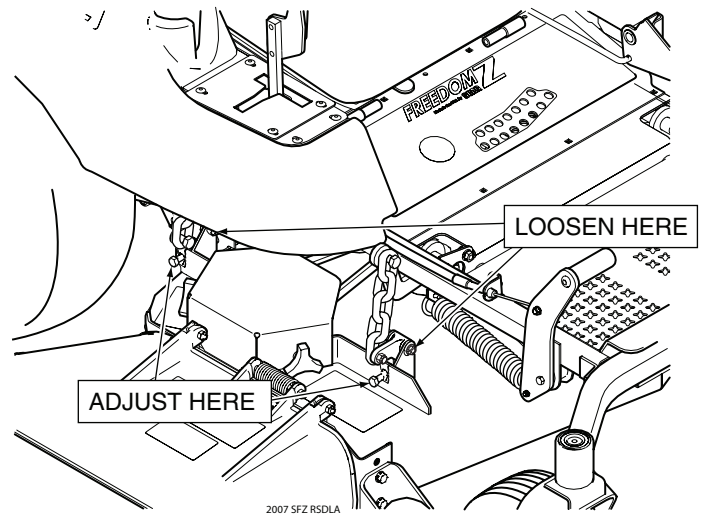

Figure 6-7. Cutter Deck Height Adjustment

4. Turn the adjustment bolts equal amount of turns either clockwise to raise or counter-clockwise to lower the cutter deck until the measurement at the cutter blade is 3" on both sides..
5. Tighten the elastic stop nuts on the deck level links.

6.7 ELECTRIC CLUTCH ADJUSTMENT

The electric clutch serves two functions in the operation of the mower. In addition to starting and stopping the power flow to the cutter blades, the clutch also acts as a brake to assist in stopping blade rotation when the PTO is switched off or the operator presence circuit is interrupted.

When the clutch is disengaged, the air gap between the armature and rotor must be adjusted to fifteen thousandths of an inch, 0.015, for proper operation. The airgap adjustment is made at three bolts on the clutch. There are three inspection windows, one next to each adjusting bolt. See Figure 6-3.

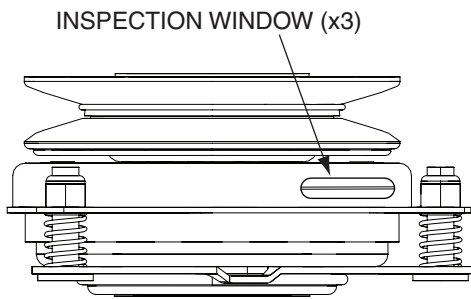

Figure 6-1. Clutch Air Gap Adjustment

1. Locate the inspection windows on the clutch.
2. Place a 0.015 feeler gauge in the slot between the rotor and the armature. See Figure 6-4.

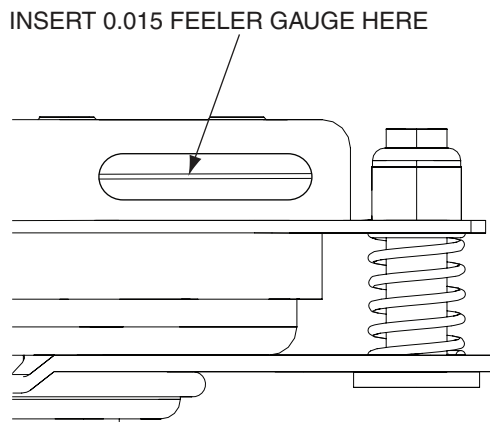

Figure 6-1. Clutch Air Gap Adjustment

3. Tighten or loosen the adjusting bolt as needed to achieve the 0.015 inch airgap. See Figure 6-5. Perform this operation at all three inspection windows.

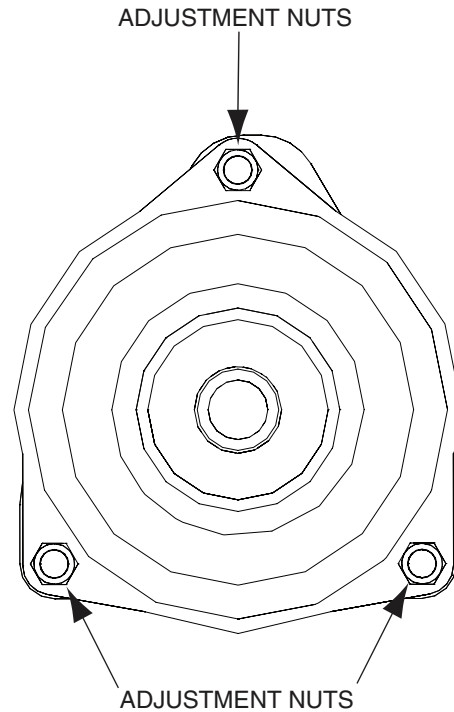

Figure 6-1. Clutch Air Gap Adjustment

This adjustment should be done every 500 hours of operation or annually, whichever comes first. In cases where the machine is heavily used, airgap settings should be checked more often.

If the air gap is too narrow, the clutch armature may drag when disengaged, resulting in premature failure.

MAINTENANCE

7.1 MAINTENANCE CHART - RECOMMENDED SERVICE INTERVALS

BREAK-IN (FIRST 10)	HOURS						PROCEDURE	COMMENTS
	8	20	40	100	200	400		
X							Check all hardware for tightness	
X							Check hydraulic oil level	See paragraph 7.2
X							Check all belts for proper alignment	See paragraph 7.7
X							Check hydraulic hoses for leaks	Use extreme caution when checking the hydraulic hoses. See paragraph 2.6
	X						Check engine oil level	See paragraph 7.3
	X						*Clean mower	See paragraph 7.10
	X						Check condition of blades	See paragraph 7.8
	X						Check tire pressure	See paragraph 7.9
	X						Inspect seat belt for wear or damage	See paragraph 2.5
	X						Check safety interlock system	See paragraph 4.2
		X					Change engine oil and filter	See paragraph 7.3
			X				Check battery, clean battery posts and cables	See paragraph 7.6
			X				Check belts for proper alignment	See paragraph 7.7
				X			Change engine oil	See paragraph 7.3
				X			Drain hydraulic system, replace hydraulic oil and filters	Use SAE 20W50 Motor Oil. See paragraph 7.2
				X			*Clean air cleaner element	See paragraph 7.5
					X		Check all hardware for tightness	
					X		Change engine oil and filter	See paragraph 7.3
					X		Check hydraulic oil level	See paragraph 7.2
						X	Replace engine fuel filter	See paragraph 7.4
						X	Drain hydraulic system, replace hydraulic oil and filters	Use SAE 20W50 Motor Oil. See paragraph 7.2
						X	Adjust electric PTO clutch	See paragraph 6.7

* Perform these maintenance procedures more frequently under extreme dusty or dirty conditions

7.2 HYDRAULIC SYSTEM

A. CHECKING HYDRAULIC OIL LEVEL

The hydraulic oil level should be checked after the first 10 hours of operation. Thereafter, check the oil after every 200 hours of machine operation or monthly, whichever occurs first.

- IMPORTANT -

If the oil level is consistently low, check for leaks and correct immediately.

1. Wipe dirt and contaminants from around the reservoir cap. Remove the cap from the hydraulic oil reservoir.
2. When the machine is "cold" (before operation), visually check the level of the hydraulic system oil. Hydraulic system oil level should be in the middle of the indicator window located on the left side of the machine. See Figure 7-2. **DO NOT** overfill; (overfilling the oil reservoir may cause oil seepage).
3. Clean the fill cap and install it onto the reservoir.

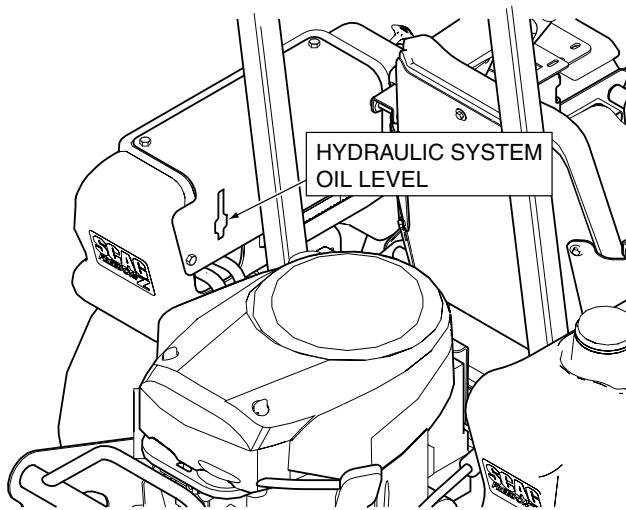

Figure 7-2. Hydraulic System Oil Level

B. CHANGING HYDRAULIC OIL

The hydraulic system oil should be changed after the first 120 hours of machine operation and every 400 hours or annually thereafter, whichever occurs first. The oil should also be changed if the color of the fluid has become black or milky. A black color and/or a rancid odor usually indicates possible overheating of the oil, and a milky color usually indicates water in the hydraulic oil.

- IMPORTANT -

The hydraulic system oil should be changed if you notice the presence of water or a rancid odor to the hydraulic oil.

1. Park the mower on a level surface and stop the engine.
2. Remove the three 1/4" filter guard screws and filter guard from both axles. See Figure 7-3. Clean any loose debris around the perimeter of the filter.

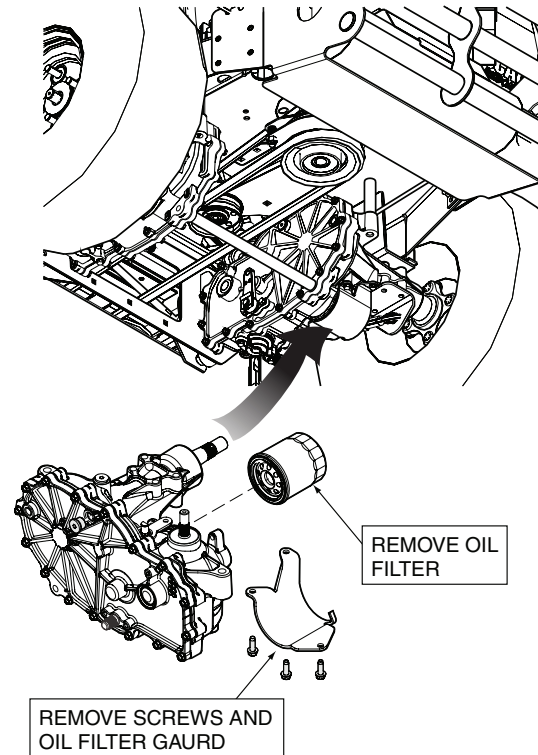

Figure 7-3. Hydraulic Oil Filter and Drain Plug

3. Place a suitable container under the hydraulic oil filters. Remove the cover from the left side tank to gain access to the hydraulic expansion reservoir. Remove the fill cap from the reservoir.
4. Remove the hydraulic filters from both axles and allow the fluid to drain into the container. Properly discard the oil when the system has drained completely. See Figure 7-3.
5. Once the hydraulic system has drained, install new hydraulic oil filters to both axles by hand, turn 3/4 to one complete turn after filter gasket contacts the filter base.
6. Reinstall the filter guards and torque the screws to 65 in/lbs.

Section 7

- Remove the top port plug from both axles before filling with oil. See Figure 7-4.

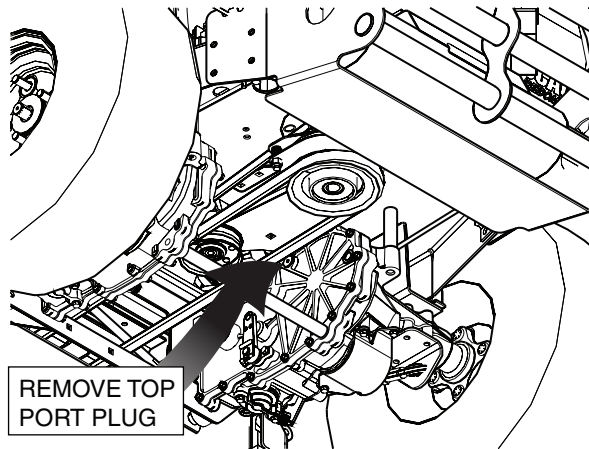

Figure 7-4. Top Port Plug Location

- Fill the hydraulic expansion reservoir with 20w50 motor oil until the oil just appears at the bottom of each axle top port. Approximately 5 quart capacity. Reinstall the top port plugs and torque to 180 in/lbs.

-NOTE-

The left side axle will fill with oil first using approximately 4 quarts of oil. Reinstall the top port plug in the left axle and continue to fill the hydraulic system through the expansion reservoir. The right side axle should fill up to the bottom on the top port plug after adding an additional one quart of oil. Reinstall the top port plug on the right axle and fill the hydraulic expansion reservoir to the proper level as explained in Section 7.2.

- Reinstall the hydraulic expansion reservoir cap.
- The hydraulic system will need to be purged of all air. Raise the rear of the machine so the drive wheels are off the ground. Use jackstands and block the front caster wheels to prevent the machine from moving.
- Move the dump valve control levers to the "freewheel" position. See Figure 7-5.

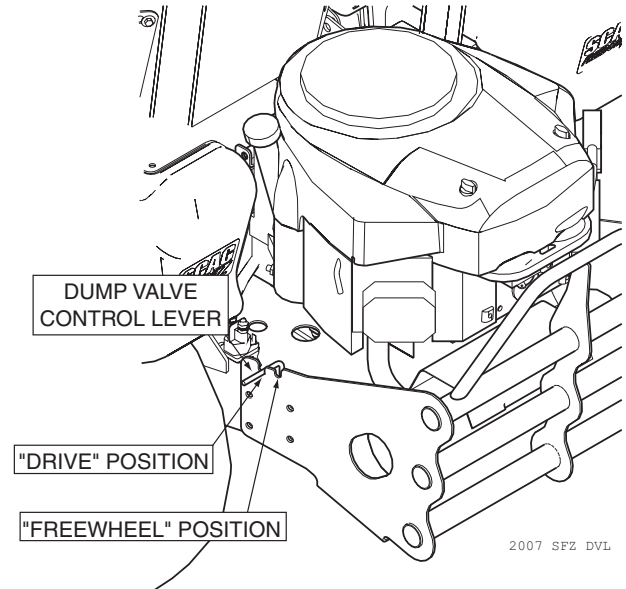

Figure 7-5. Dump Valve Control Lever

- While in the operator's position, start the engine and disengage the parking brake.
- Run the engine at 1/2 throttle and move the steering control levers to full forward and reverse 5 to 6 times.
- Engage the parking brake. Move the dump valve control levers to the "drive" position. See Figure 7-5.
- While in the operator's position, run the engine at 1/2 throttle. Release the parking brake, move the steering control levers to full forward and reverse 5 to 6 times. It may be necessary to repeat steps 12 to 15 until the air is completely purged from the system.
- Check the hydraulic system oil level as explained in Section 7.2.

7.3 ENGINE OIL

A. CHECKING ENGINE CRANKCASE OIL LEVEL

The engine oil level should be checked after every 8 hours of operation or daily as instructed in the Engine Operator's Manual furnished with this mower.

B. CHANGING ENGINE CRANKCASE OIL

After the first 20 hours of operation, change the engine crankcase oil and replace the oil filter. Thereafter, change the engine crankcase oil after every 100 hours of operation or bi-weekly, whichever occurs first. Refer to the Engine Operator's Manual furnished with this mower for instructions.

C. CHANGING ENGINE OIL FILTER

After the first 20 hours of operation, replace the engine oil filter. Thereafter, replace the oil filter after every 200 hours of operation or every month, whichever occurs first. Refer to Engine Operator's Manual for instructions.

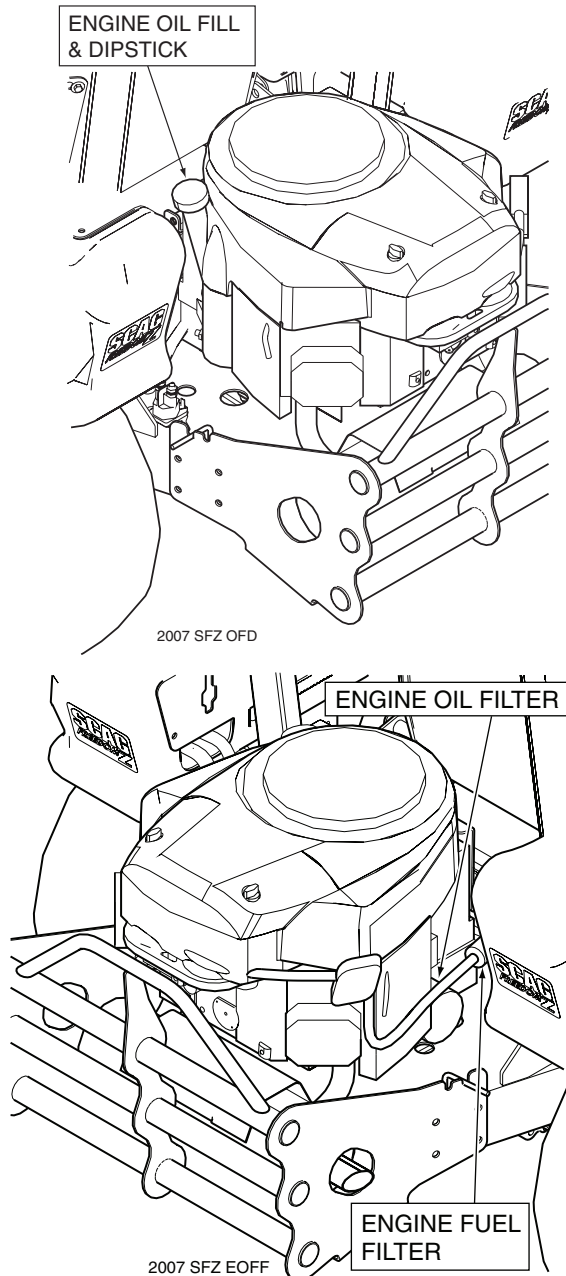

Figure 7-6. Oil Fill / Dipstick, Oil Filter, Fuel Filter

7.4 ENGINE FUEL SYSTEM

DANGER

To avoid injury from burns, allow the mower to cool before removing the fuel tank cap and refueling.

A. FILLING THE FUEL TANK

Fill the fuel tank at the beginning of each operating day to within one (1) inch below the filler neck. Do not overfill. Use clean, fresh unleaded gasoline with a minimum octane rating of 87 and a maximum of 10% Ethanol.

DO NOT use E85 Fuel. Using E85 Fuel will cause severe damage to the engine.

To avoid personal injury or property damage, use extreme care in handling gasoline. Gasoline is extremely flammable and the vapors are explosive.

1. Extinguish all cigarettes, cigars, pipes and other sources of ignition.
2. Use only an approved gasoline container.
3. Never remove the gas cap or add fuel with the engine running. Allow the engine to completely cool before fueling.
4. Never fuel the machine indoors or in an enclosed trailer.
5. Never store the machine or fuel container where there is an open flame, spark or pilot light such as on a water heater or other appliances.
6. Never fill containers inside a vehicle or on a truck or trailer bed with a plastic liner. Always place containers on the ground away from your vehicle before filling.
7. Remove the machine from the truck or trailer and fuel on the ground. If this is not possible, then refuel the machine with a portable container, rather than from a gasoline dispenser nozzle.
8. Keep the nozzle in contact with the rim of fuel tank or container opening at all times until fueling is complete. Do not use a nozzle lock-open device.

Section 7

9. If fuel is spilled on clothing, change clothing immediately and wash affected skin.
10. Replace gas cap and tighten securely.

B. REPLACING IN-LINE FUEL FILTER ELEMENTS

The engine fuel filter should be replaced after every 400 hours of operation or annually, whichever occurs first. See Figure 7-7.

1. Close the shut-off valve.
2. Remove and replace the engine fuel filter. Open the fuel shut-off valve.

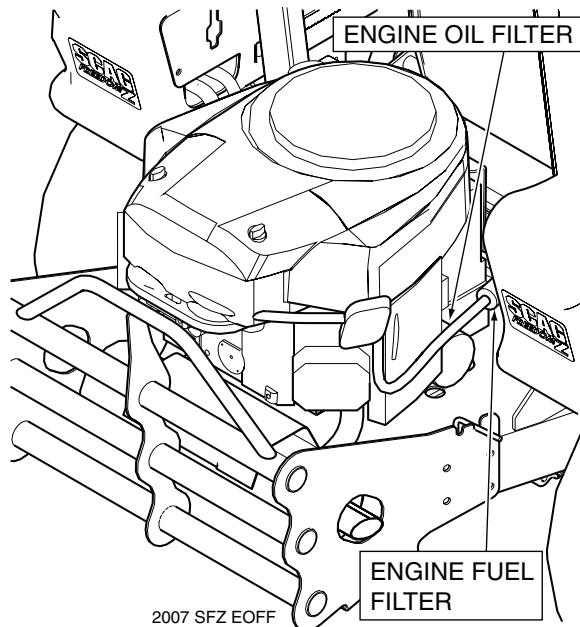

Figure 7-7. Fuel Filter

7.5 ENGINE AIR CLEANER

A. CLEANING AND/OR REPLACING AIR CLEANER ELEMENT

For any air cleaner, the operating environment dictates the air cleaner service periods. Inspect and clean the air cleaner element after every 100 hours of operation or bi-weekly, whichever occurs first and replace the element if required.

- NOTE -

In extremely dusty conditions it may be necessary to check the element once or twice daily to prevent engine damage.

1. Loosen the two bolts securing the air cleaner cover to the air cleaner assembly and remove the cover. Set aside.
2. Remove the air cleaner and inspect.
3. Clean or replace the air cleaner and foam pre-cleaner as recommended by the engine manufacturer.
4. Replace the air cleaner cover and secure.

7.6 BATTERY

! WARNING

Lead-acid batteries produce flammable and explosive gases. To avoid personal injury when checking, testing or charging batteries, **DO NOT** use smoking materials near batteries. Keep arcs, sparks and flames away from batteries. Provide proper ventilation and wear safety glasses.

! WARNING

Battery posts, terminals, and related accessories contain lead and lead compounds, chemicals known to cause cancer and reproductive harm. Wash hands after handling.

WARNING

Electric storage battery fluid contains sulfuric acid which is **POISON** and can cause **SEVERE CHEMICAL BURNS**. Avoid contact of fluid with eyes, skin, or clothing. Use proper protective gear when handling batteries. **DO NOT** tip any battery beyond 45° angle in any direction. If fluid contact does occur, follow first aid suggestions below.

BATTERY ELECTROLYTE FIRST AID

External Contact — Flush with water.

Eyes — Flush with water for at least 15 minutes and get medical attention immediately.

Internal — Drink large quantities of water. Follow with Milk Of Magnesia, beaten egg, or vegetable oil. Get medical attention immediately. In case of internal contact, DO NOT give fluids that would induce vomiting.

Charging rates between 3 and 50 amperes are satisfactory if excessive gassing or spewing of electrolyte does not occur or the battery does not feel excessively hot (over 125°F). If spewing or gassing occurs or the temperature exceeds 125°F, the charging rate must be reduced or temporarily stopped to permit cooling.

B. JUMP STARTING

1. The booster battery must be a 12 volt type. If a vehicle is used for jump starting, it must have a negative ground system.
2. When connecting the jumper cables, connect the positive cable to the positive battery post, then connect the negative cable to the negative battery post.

7.7 DRIVE BELTS

All drive belts are spring-loaded and self-tensioning, however after the first 2, 4, 8 and 10 hours of operation, the belts should be checked for proper alignment and wear. Thereafter, check the belts after every 40 hours of operation or weekly, whichever occurs first.

- NOTE -

If you experience frequent belt wear or breakage, see your authorized Scag service center for belt adjustment.

A. CHARGING THE BATTERY

Refer to the battery charger's manual for specific instructions.

Under normal conditions the engine's alternator will have no problem keeping a charge on the battery. If the battery has been completely discharged for a long period of time, the alternator may not be able to recharge the battery, and a battery charger will be required.

DO NOT charge a frozen battery. It may explode and cause injury. Let the battery warm before attaching a charger.

Whenever possible, remove the battery from the mower before charging and make sure the electrolyte covers the plates in all cells.

WARNING

BATTERIES PRODUCE EXPLOSIVE GASES. Charge the battery in a well ventilated space so gases produced while charging can dissipate.

Section 7

7.8 CUTTER BLADES

A. BLADE INSPECTION

1. Remove the ignition key before servicing the blades.
2. Raise the mower deck to the highest position. Place the lanyard pin in the highest cutting height position to prevent the cutter deck from falling.

WARNING

Always wear proper hand and eye protection when working with cutter blades.

3. Check the cutter blades for straightness. If the cutter blades appear bent, they will need to be replaced.

WARNING

Do not attempt to straighten a bent blade, and never weld a broken or cracked blade. Always replace it with a new blade to assure safety.

4. If a blade cutting edge is dull or nicked, it should be sharpened. Remove the blades for sharpening. See "Blade Replacement."

- NOTE -

Keep the blades sharp. Cutting with dull blades not only yields a poor mowing job, but slows the cutting speed of the mower and causes extra wear on the engine and the blade drive by pulling hard.

B. BLADE SHARPENING

- NOTE -

If possible, use a file to sharpen the blade. Using a wheel grinder may burn the blade.

- NOTE -

DO NOT sharpen the blades beyond 1/3 of the width of the blade. See Figure 7-8.

1. Sharpen the cutting edge at the same bevel as the original. See Figure 7-8. Sharpen only the top of the cutting edge to maintain sharpness.

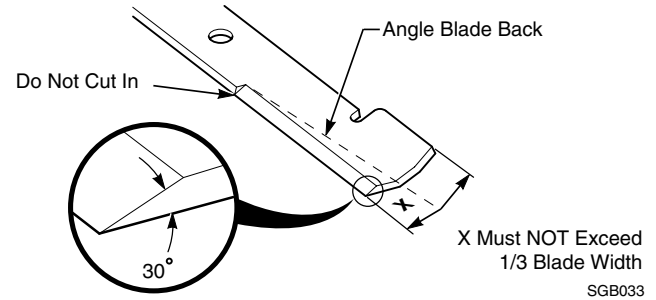

Figure 7-8. Blade Sharpening

2. Check the balance of the blade. If the blades are out of balance, vibration and premature wear can occur. See your authorized Scag dealer for blade balancing or special tools, if you choose to balance your own blades.

C. BLADE REPLACEMENT

WARNING

Always wear proper hand and eye protection when working with cutter blades.

1. Remove the ignition key before replacing the blades.
2. Raise the mower deck to the highest position. Place the lanyard pin in the highest cutting height position to prevent the cutter deck from falling.
3. Secure the cutter blades to prevent them from rotating, (use the optional Blade Buddy tool P/N 9212, to assist in securing the cutter blades), remove the blade attaching bolt. Remove the cutter blade, bolt, lockwasher and flatwasher from the spindle shaft. See Figure 7-9.
4. To install the new cutter blade, put the lockwasher and flatwasher onto the blade bolt and slide the bolt into the hole in the cutter blade.

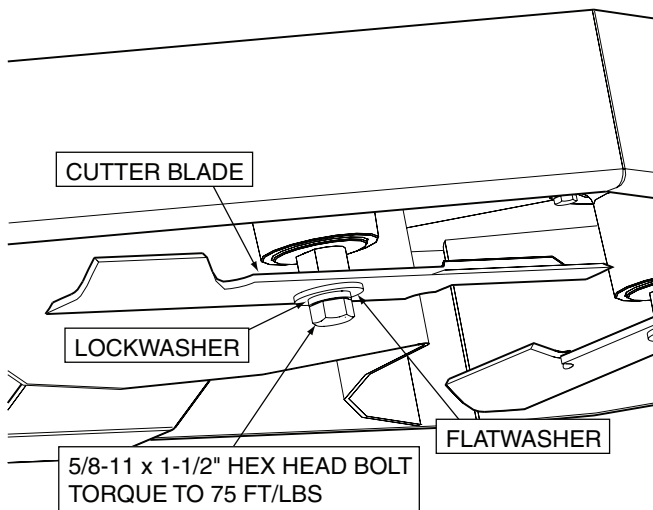

Figure 7-9. Blade Replacement

- NOTE -

Be sure that the blade is installed with the lift wing toward the top.

2. Do not spray electrical components.
3. Use a mild soap solution or a vinyl/rubber cleaner to clean the seat.
4. Repair damaged metal surfaces using Scag touch-up paint available from your authorized Scag dealer. Wax the mower for maximum paint protection.
5. Install the cutter blade onto the cutter spindle shaft. Secure the blades from rotating and torque to 75 ft/lbs. See Figure 7-9.

7.9 TIRES

Check the tire pressures after every 8 hours of operation or daily.

Caster Wheels	25 PSI
Drive Wheels	8 PSI

7.10 BODY, DECK, AND UPHOLSTERY

⚠ CAUTION

Do not wash any portion of the equipment while it is hot. Do not wash the engine; use compressed air.

1. After each use, wash the mower and cutter deck. Use cold water and automotive cleaners. Do not use pressure cleaners.

ILLUSTRATED PARTS LIST

8.1 SCAG APPROVED ATTACHMENTS AND ACCESSORIES.

Attachments and accessories manufactured by companies other than Scag Power Equipment are not approved for use on this machine.

Scag approved attachments and accessories:

- GC-SFZ (p/n 9074, requires p/n 9069, 9070 9071 or 9073 baffle kit)
- Mulch Plate (p/n 920G, 9298, 9299, 920U)
- Hurricane Mulch (p/n 920D, 9293, 9294, 920T)
- SFZ Hitch (p/n 9296 - SFZ48, SFZ52 & SFZ61 Only)
- Freedom Striper (p/n 9297 - SFZ48, SFZ52 & SFZ61 Only)
- GC-4D (p/n 9054 - SFZ48, SFZ52 & SFZ61 Only)
- GC-F4 (p/n 9055 - SFZ48, SFZ52 & SFZ61 Only)
- Blade Buddy (p/n 9212)
- SFZ Lights (p/n 920A)
- 8" Chrome Wheel Covers (set of 2) (p/n 920H) - Not Available for SFZ36

36 CUTTER DECK

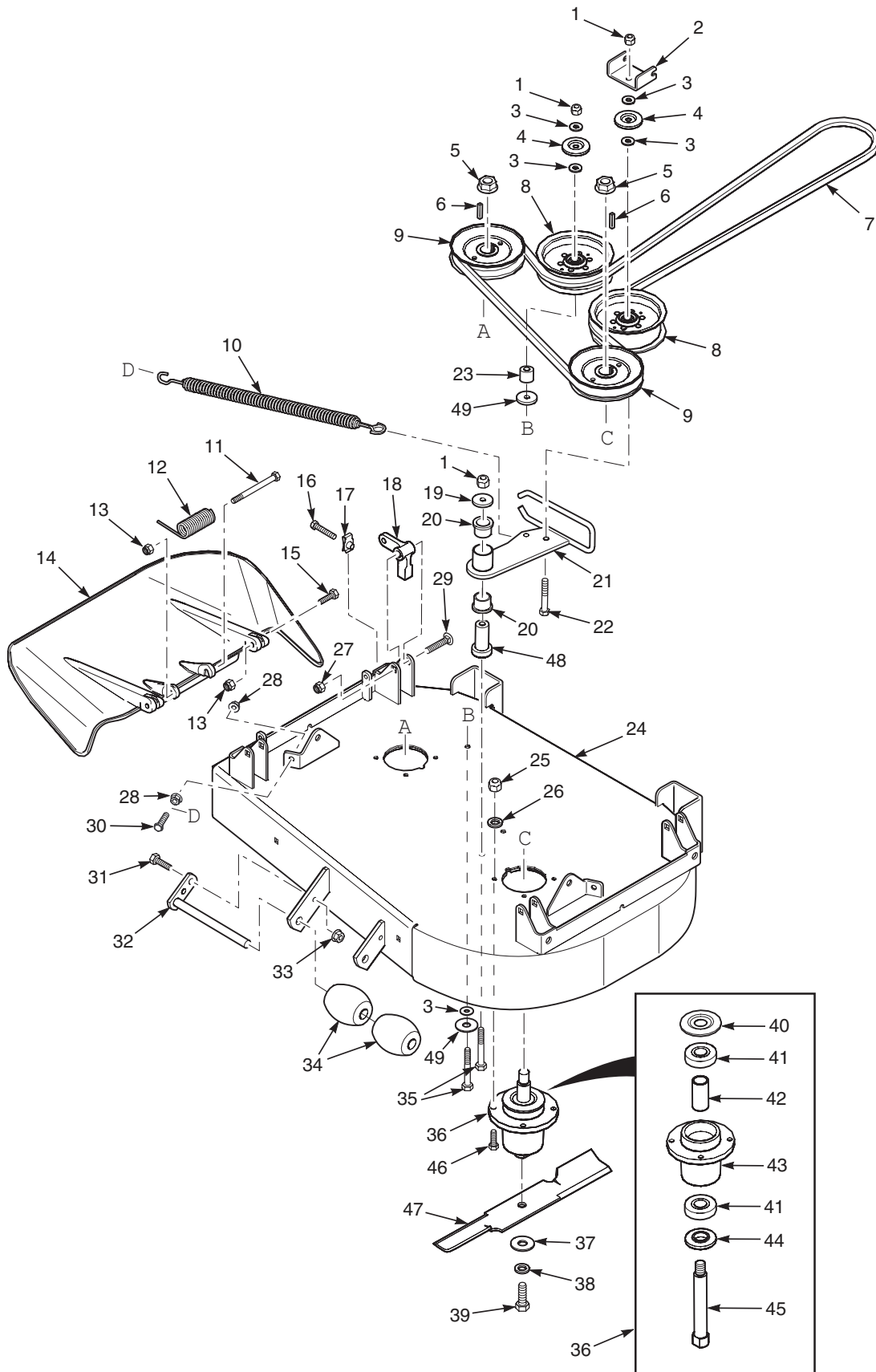

36 CUTTER DECK

Ref. No.	Part No.	Description
1	04021-09	Nut, Elastic Stop 3/8-16
2	424615	Bracket, Belt Guide
3	04043-04	Flatwasher, 3/8-.391 x .938 x .105
4	424367	Dust Shield
5	04112-06	Nut, 3/4-16 Spiral Lock
6	04063-01	Key, 1/4 x 1/4 x 1-1/4"
7	483667	Belt, Cutter Deck
8	483442	Pulley, 5" Idler
9	483324	Pulley, 5.73" OD - 25mm Bore
10	483375	Spring, Idler
11	04001-154	Bolt, Hex Head 5/16-18 x 4-3/4"
12	482245	Spring, Discharge Chute
13	04021-10	Nut, Elastic Stop 5/16-18
14	462031	Discharge Chute Assembly
15	04001-12	Bolt, Hex Head 5/16-18 x 1-3/4"
16	04107-05	Bolt, Hex Head 3/8-16 x 2" Special Lock
17	04110-03	U-Nut, 3/8-16
18	483361	Lever, Deck Level
19	04041-11	Flatwasher, 3/8-.406 x 1.50" x 7 Ga.
20	483453-03	Bearing
21	462133	Idler Arm (incl. item #20)
22	04001-31	Bolt, Hex Head 3/8-16 x 2-1/2"
23	43711	Spacer
24	462135	Cutter Deck w/Decals, SFZ36
25	04021-22	Nut, Elastic Stop 5/16-18

Ref. No.	Part No.	Description
26	04030-03	Lockwasher, 5/16 Spring
27	04021-11	Nut, Elastic Stop 7/16-14
28	04019-04	Nut, Serrated Flange 3/8-16
29	04003-42	Bolt, Carriage 7/16-14 x 2-1/4"
30	04001-136	Bolt, Hex Head 3/8-16 x 1-1/2" Gr.8
31	04001-09	Bolt, Hex Head 5/16-18 x 1"
32	451926	Shaft Weldment
33	04019-03	Nut, Serrated Flange 5/16-18
34	482295	Wheel, Anti-Scalp
35	04001-77	Bolt, Hex Head 3/8-16 x 3-1/2"
36	461950	Spindle Assembly
37	04043-06	Flatwasher, 5/8-11 x 1-1/2"
38	04030-07	Lockwasher, 1/2 Spring
39	04001-121	Bolt, Hex Head 5/8-11 x 1-1/2"
40	483304	Debris Shield
41	483303	Bearing
42	43693	Spacer, Bearing
43	462014	Spindle Housing Assembly (incl. item #41, 42)
44	43694	Protector, Bearing
45	43695	Shaft, Spindle
46	04001-175	Bolt, Hex Head 5/16-18 x 1-1/2" Gr.8
47	482878	Cutter Blade, 48"
48	43708	Pivot, Idler
49	04041-38	Flatwasher, 3/8-.406 x 2.25" x .1875

48, 52 & 61 CUTTER DECKS

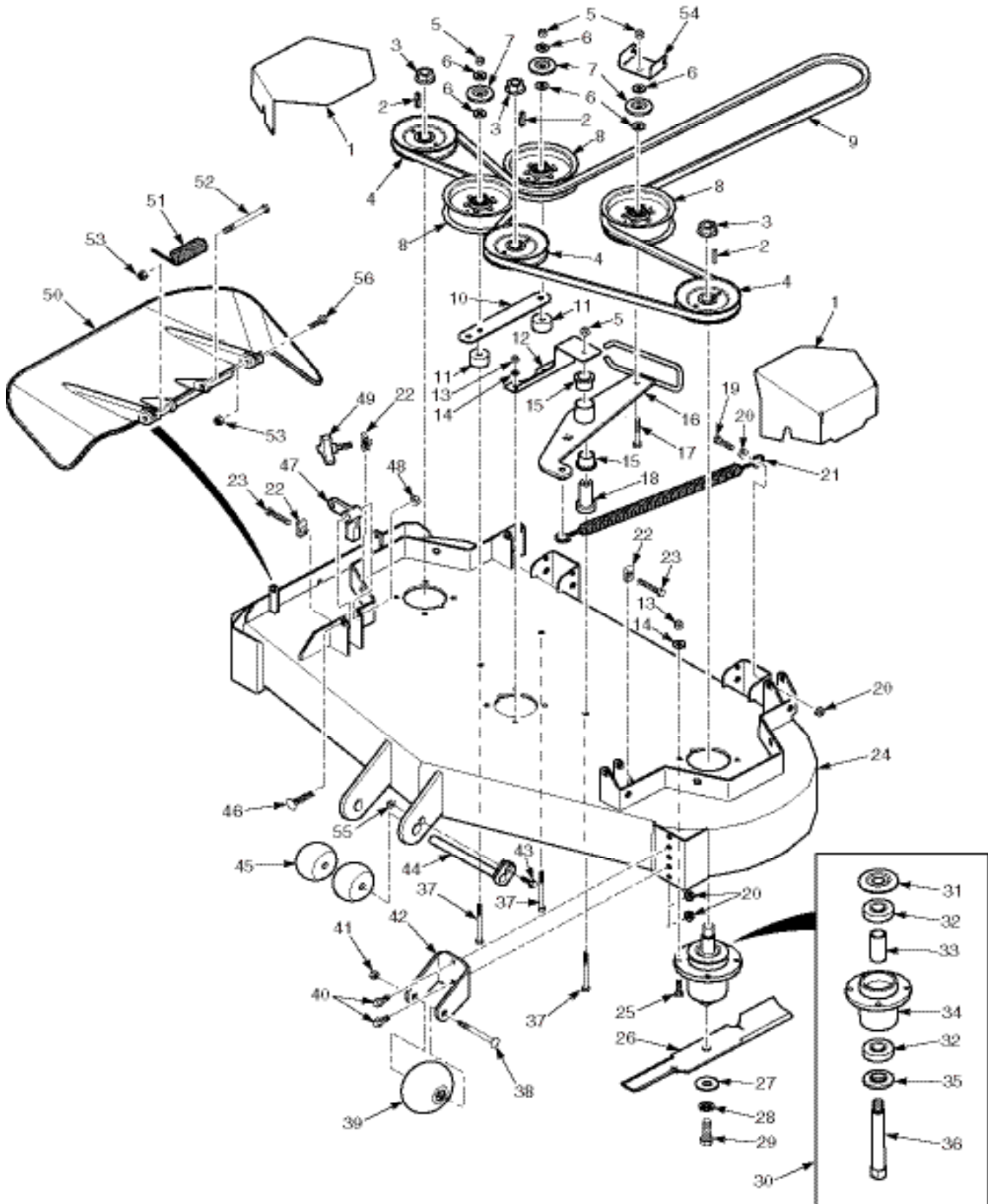

48, 52 & 61 CUTTER DECKS

	Part No.	Description	48	52	61
1	424528	Belt Cover	x	x	
	425260	Belt Cover			x
2	04063-01	Key, 1/4 x 1/4 x 1-1/4"	x	x	x
3	04112-06	Nut, 3/4-16 Spiral Lock	x	x	x
4	483323	Pulley, 5.13" OD - 25mm Bore	x		
	483324	Pulley, 5.73" OD - 25mm Bore		x	
	484026	Pulley, 6.32" OD - 25mm Bore			x
5	04021-09	Nut, Elastic Stop 3/8-16	x	x	x
6	04043-04	Flatwasher, 3/8-.391 x .938 x .105	x	x	x
7	424367	Dust Shield	x	x	x
8	483422	Pulley, 5" Idler	x	x	x
9	483325	Belt, Cutter Deck	x		
	483326	Belt, Cutter Deck		x	
	484031	Belt, Cutter Deck			x
10	424479	Brace, Pulley	x	x	x
11	43711	Spacer	x	x	x
12	424548	Support, Idler Pivot	x		
	424547	Support, Idler Pivot		x	
	425264	Support, Idler Pivot			x
13	04021-22	Nut, Elastic Stop	x	x	x
14	04030-03	Lockwasher, 5/16 Spring	x	x	x
15	483453-03	Bearing	x	x	x
16	462037	Idler Arm (incl. item #15)	x	x	x
17	04001-31	Bolt, Hex Head 3/8-16 x 2-1/2"	x	x	x
18	43708	Pivot, Idler	x	x	x
19	04001-136	Bolt, Hex Head 3/8-16 x 1-1/2 Gr.8	x	x	x
20	04019-04	Nut, Serrated Flange 3/8-16	x	x	x
21	483375	Spring, Idler	x	x	x
22	04110-03	U-Nut, 3/8-16	x	x	x
23	04107-04	Bolt, Hex Head 3/8-16 x 2" Special Lock	x	x	x
24	462039	Cutter Deck w/Decals, SFZ48	x		
	462040	Cutter Deck w/Decals, SFZ52		x	
	462227	Cutter Deck w/Decals, SFZ61			x
25	04001-11	Bolt, Hex Head 5/16-18 x 1-1/2"	x	x	x
26	482877	Cutter Blade, 16-1/2"	x		
	482878	Cutter Blade, 18"		x	
	482879	Cutter Blade, 21"			x

	Part No.	Description	48	52	61
27	04043-06	Flatwasher, 5/8-.688 x 1.75 x .134 HD	x	x	x
28	04030-07	Lockwasher, 1/2 Spring	x	x	x
29	04001-121	Bolt, Hex Head 5/8-11 x 1-1/2"	x	x	x
30	461950	Spindle Assembly	x	x	x
31	483304	Debris Shield	x	x	x
32	483303	Bearing	x	x	x
33	43693	Spacer	x	x	x
34	462014	Spindle Housing Assembly (Incl. item #32, 33)	x	x	x
35	43694	Protector, Bearing	x	x	x
36	43695	Shaft, Spindle	x	x	x
37	04001-77	Bolt, Hex Head 3/8-16 x 3-1/2"	x	x	x
38	04003-26	Bolt, Carriage 3/8-16 x 4"	x	x	x
39	481632	Wheel, Anti-Scalp	x	x	x
40	04017-27	Bolt, Hex Head 3/8-16 x 1" Ser. Fig.	x	x	x
41	04021-05	Nut, Center Lock 3/8-16	x	x	x
42	422478	Bracket, Anti-Scalp	x	x	x
43	04001-09	Bolt, Hex Head 5/16-18 x 1"	x	x	x
44	451926	Shaft Weldment	x	x	x
45	482295	Wheel, Anti-Scalp	x	x	x
46	04003-42	Bolt, Carriage 7/16-14 x 2-1/4"	x	x	x
47	483361	Lever, Deck Level	x	x	x
48	04021-11	Nut, Elastic Stop 7/16-14	x	x	x
49	481625-01	Knob w/Stud	x	x	x
50	462031	Discharge Chute Assembly	x		
	462032	Discharge Chute Assembly		x	
	462213	Discharge Chute Assembly			x
51	482245	Spring, Discharge Chute	x	x	x
52	04001-154	Bolt, Hex Head 5/16-18 x 4-3/4"	x	x	x
53	04021-10	Nut, Elastic Stop 5/16-18	x	x	x
54	424615	Bracket, Belt Guide	x	x	x
55	04019-03	Nut, Serrated Flange 5/16-18	x	x	x
56	04001-12	Bolt, Hex Head 5/16-18 x 1-3/4"	x	x	x

CUTTER DECK CONTROLS - SFZ36

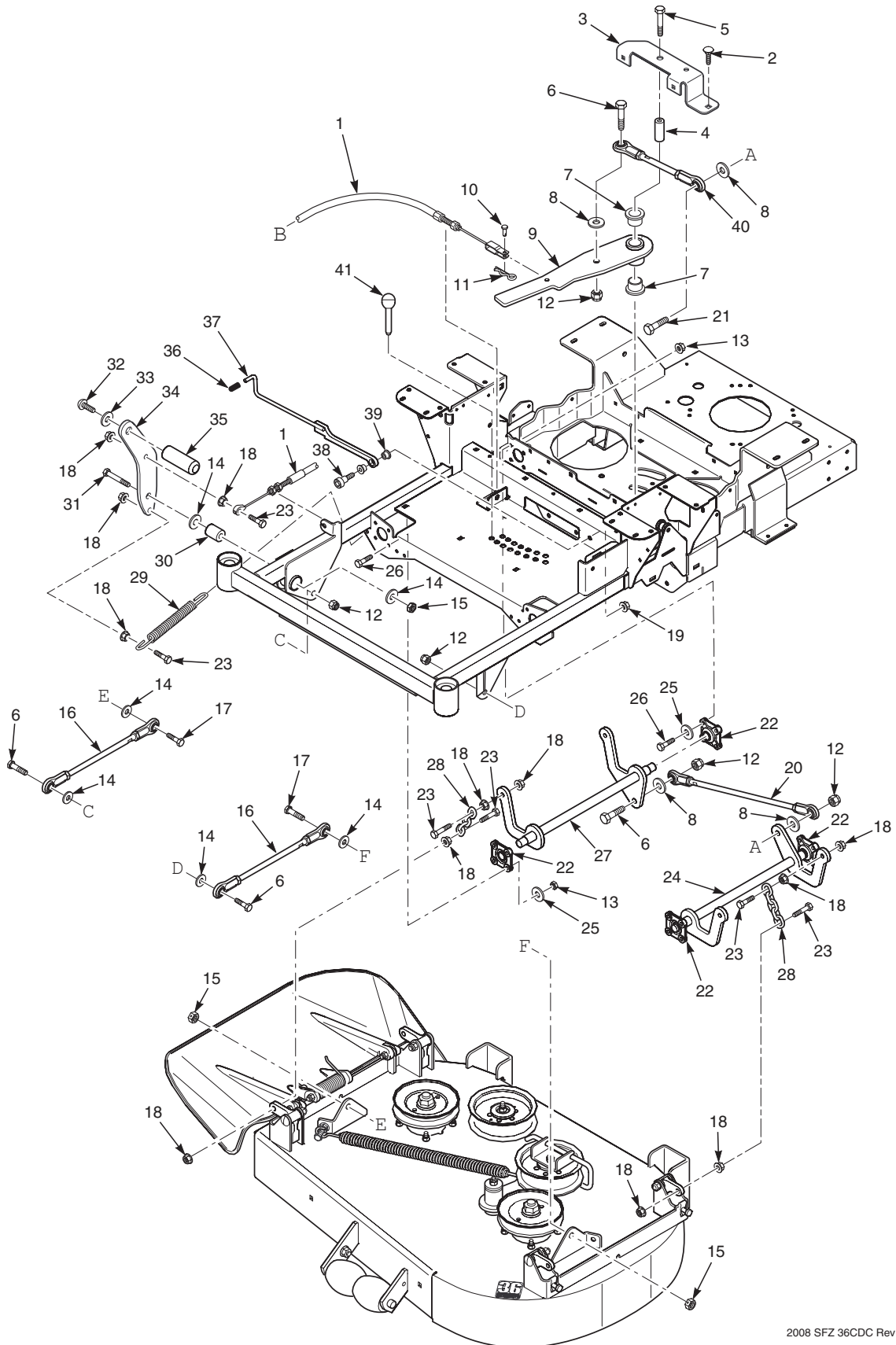

CUTTER DECK CONTROLS - SFZ36

Ref. No.	Part No.	Description
1	483341	Cable, Deck Lift
2	04003-31	Bolt, Carriage 3/8-16 x 3/4"
3	424827	Support, Idler Arm
4	43710	Spacer, Deck Lift Pivot
5	04001-90	Bolt, Hex Head 1/2-13 x 3-3/4"
6	04001-183	Bolt, Hex Head 1/2-13 x 1-3/4"
7	483453-03	Bearing
8	04040-07	Flatwasher, 1/2-.531 x 1.06 x .095
9	461999	Deck Lift Bellcrank Assembly
10	04064-17	Clevis Pin, 5/16 x 3/4"
11	04062-01	Hair Pin, .094 x 1.62"
12	04021-07	Nut, Elastic Stop 1/2-13
13	04021-10	Nut, Elastic Stop 5/16-18
14	04040-13	Flatwasher, 1/2-.562 x 1.375 x .109
15	04021-09	Nut, Center Lock 1/2-13
16	483332	Linkage, Push Arm
17	04001-71	Bolt, Hex Head 1/2-13 x 1-1/2"
18	04019-04	Nut, Serrated Flange 3/8-16
19	04021-09	Nut, Elastic Stop 3/8-16
20	483349	Linkage Assembly, Deck Lift
21	04001-52	Bolt, Hex Head 1/2-13 x 2-1/2"
22	483334	Bearing, Deck Lift
23	04001-20	Bolt, Hex Head 3/8-16 x 1-1/2"
24	451982	Weldment, Deck Lift LH
25	04040-14	Flatwasher, 1/4-.312 x .750 x .065
26	04001-09	Bolt, Hex Head 5/16-18 x 1"
27	451983	Weldment, Deck Lift RH
28	482628	Chain, Deck lift
29	483374	Spring, Deck Lift
30	43710	Sleeve, Deck Lift Pivot
31	04001-74	Bolt, Hex Head 1/2-13 x 3"
32	04105-01	Bolt, Head Socket 5/8-11 x 1-1/2"
33	04030-07	Lockwasher, 5/8 Spring
34	424844	Pedal, Foot Bracket
35	424504	Foot Pedal
36	483492	Grip, Deck Latch
37	491254	Weldment, Deck Latch
38	04009-06	Bolt, Shoulder 1/2 x 1/2
39	483453-10	Bearing
40	483328	Linkage Assembly, Deck Lift
41	483498	Pin, Height Adjuster

CUTTER DECK CONTROLS - SFZ48 & SFZ52

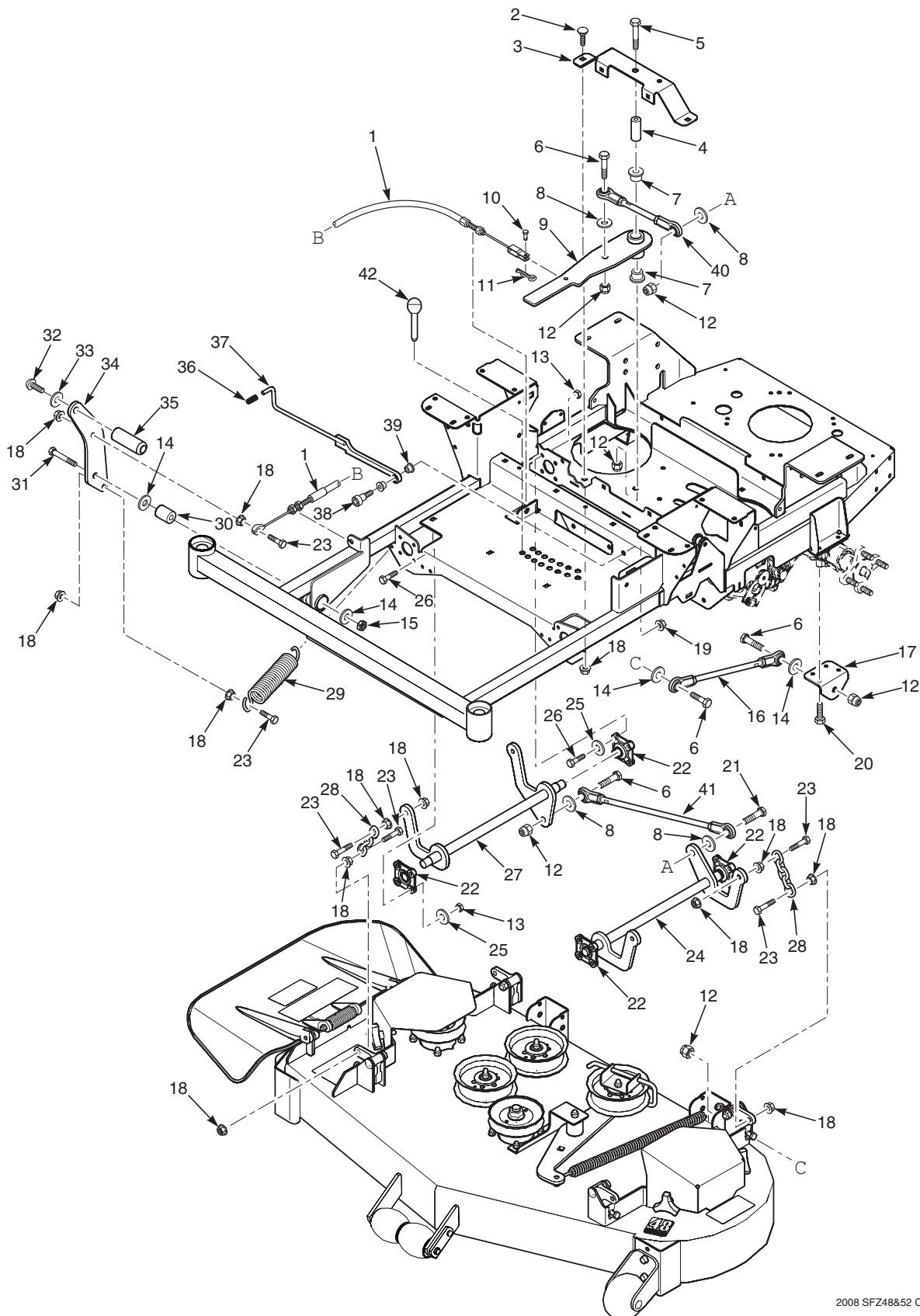

CUTTER DECK CONTROLS - SFZ48 & SFZ52

Ref. No.	Part No.	Description
1	483341	Cable, Deck Lift
2	04003-31	Bolt, Carriage 3/8-16 x 3/4"
3	424476	Support, Idler Arm
4	43710	Spacer, Deck Lift Pivot
5	04001-90	Bolt, Hex Head 1/2-13 x 3-3/4"
6	04001-183	Bolt, Hex Head 1/2-13 x 1-3/4"
7	483453-03	Bearing
8	04040-07	Flatwasher, 1/2-.531 x 1.06 x .095
9	461999	Deck Lift Bellcrank Assembly
10	04064-17	Clevis Pin, 5/16 x 3/4"
11	04062-01	Hair Pin, .094 x 1.62"
12	04021-07	Nut, Elastic Stop 1/2-13
13	04021-10	Nut, Elastic Stop 5/16-18
14	04040-13	Flatwasher, 1/2-.562 x 1.375 x .109
15	04021-09	Nut, Center Lock 1/2-13
16	483332	Linkage, Push Arm
17	424489	Bracket, Push Arm Link
18	04019-04	Nut, Serrated Flange 3/8-16
19	04021-09	Nut, Elastic Stop 3/8-16
20	04001-49	Bolt, Hex Head 5/16-18 x 3"
21	04001-52	Bolt, Hex Head 1/2-13 x 2-1/2"
22	483334	Bearing, Deck Lift
23	04001-20	Bolt, Hex Head 3/8-16 x 1-1/2"
24	451868	Weldment, Deck Lift LH
25	04040-14	Flatwasher, 1/4-.312 x .750 x .065
26	04001-09	Bolt, Hex Head 5/16-18 x 1"
27	451867	Weldment, Deck Lift RH
28	482628	Chain, Deck lift
29	483374	Spring, Deck Lift
30	43710	Sleeve, Deck Lift Pivot
31	04001-74	Bolt, Hex Head 1/2-13 x 3"
32	04105-01	Bolt, Head Socket 5/8-11 x 1-1/2"
33	04030-07	Lockwasher, 5/8 Spring
34	424535	Pedal, Foot Bracket
35	424504	Foot Pedal
36	483492	Grip, Deck Latch
37	491254	Weldment, Deck Latch
38	04009-06	Bolt, Shoulder 1/2 x 1/2
39	483453-10	Bearing
40	483328	Linkage Assembly, Deck Lift
41	483367	Linkage Assembly, Deck Lift
42	483498	Pin, Height Adjuster

CUTTER DECK CONTROLS - SFZ61

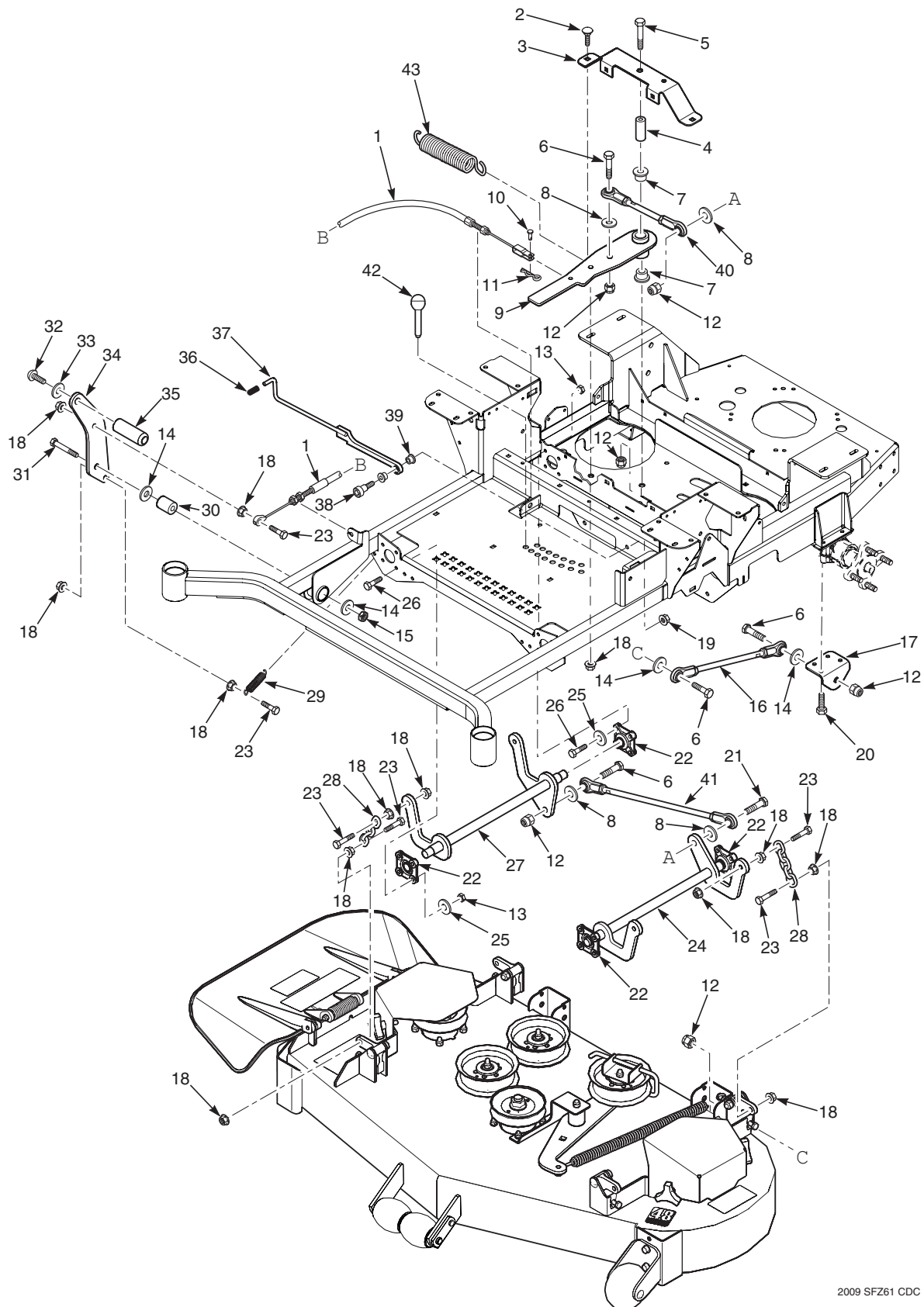

2009 SFZ61 CDC

CUTTER DECK CONTROLS - SFZ61

Ref. No.	Part No.	Description
1	483341	Cable, Deck Lift
2	04003-31	Bolt, Carriage 3/8-16 x 3/4"
3	424476	Support, Idler Arm
4	43710	Spacer, Deck Lift Pivot
5	04001-90	Bolt, Hex Head 1/2-13 x 3-3/4"
6	04001-183	Bolt, Hex Head 1/2-13 x 1-3/4"
7	483453-03	Bearing
8	04040-07	Flatwasher, 1/2-.531 x 1.06 x .095
9	461999	Deck Lift Bellcrank Assembly
10	04064-17	Clevis Pin, 5/16 x 3/4"
11	04062-01	Hair Pin, .094 x 1.62"
12	04021-07	Nut, Elastic Stop 1/2-13
13	04021-10	Nut, Elastic Stop 5/16-18
14	04040-13	Flatwasher, 1/2-.562 x 1.375 x .109
15	04021-09	Nut, Center Lock 1/2-13
16	483332	Linkage, Push Arm
17	424489	Bracket, Push Arm Link
18	04019-04	Nut, Serrated Flange 3/8-16
19	04021-09	Nut, Elastic Stop 3/8-16
20	04001-49	Bolt, Hex Head 5/16-18 x 3"
21	04001-52	Bolt, Hex Head 1/2-13 x 2-1/2"
22	483334	Bearing, Deck Lift
23	04001-20	Bolt, Hex Head 3/8-16 x 1-1/2"
24	452112	Weldment, Deck Lift LH
25	04040-14	Flatwasher, 1/4-.312 x .750 x .065
26	04001-09	Bolt, Hex Head 5/16-18 x 1"
27	452113	Weldment, Deck Lift RH
28	482628	Chain, Deck lift
29	484038	Spring, Deck Lift
30	43710	Sleeve, Deck Lift Pivot
31	04001-74	Bolt, Hex Head 1/2-13 x 3"
32	04105-01	Bolt, Head Socket 5/8-11 x 1-1/2"
33	04030-07	Lockwasher, 5/8 Spring
34	424535	Pedal, Foot Bracket
35	424504	Foot Pedal
36	483492	Grip, Deck Latch
37	491254	Weldment, Deck Latch
38	04009-06	Bolt, Shoulder 1/2 x 1/2
39	483453-10	Bearing
40	483328	Linkage Assembly, Deck Lift
41	483367	Linkage Assembly, Deck Lift
42	483498	Pin, Height Adjuster
43	483374	Spring, Deck Lift

SHEET METAL COMPONENTS

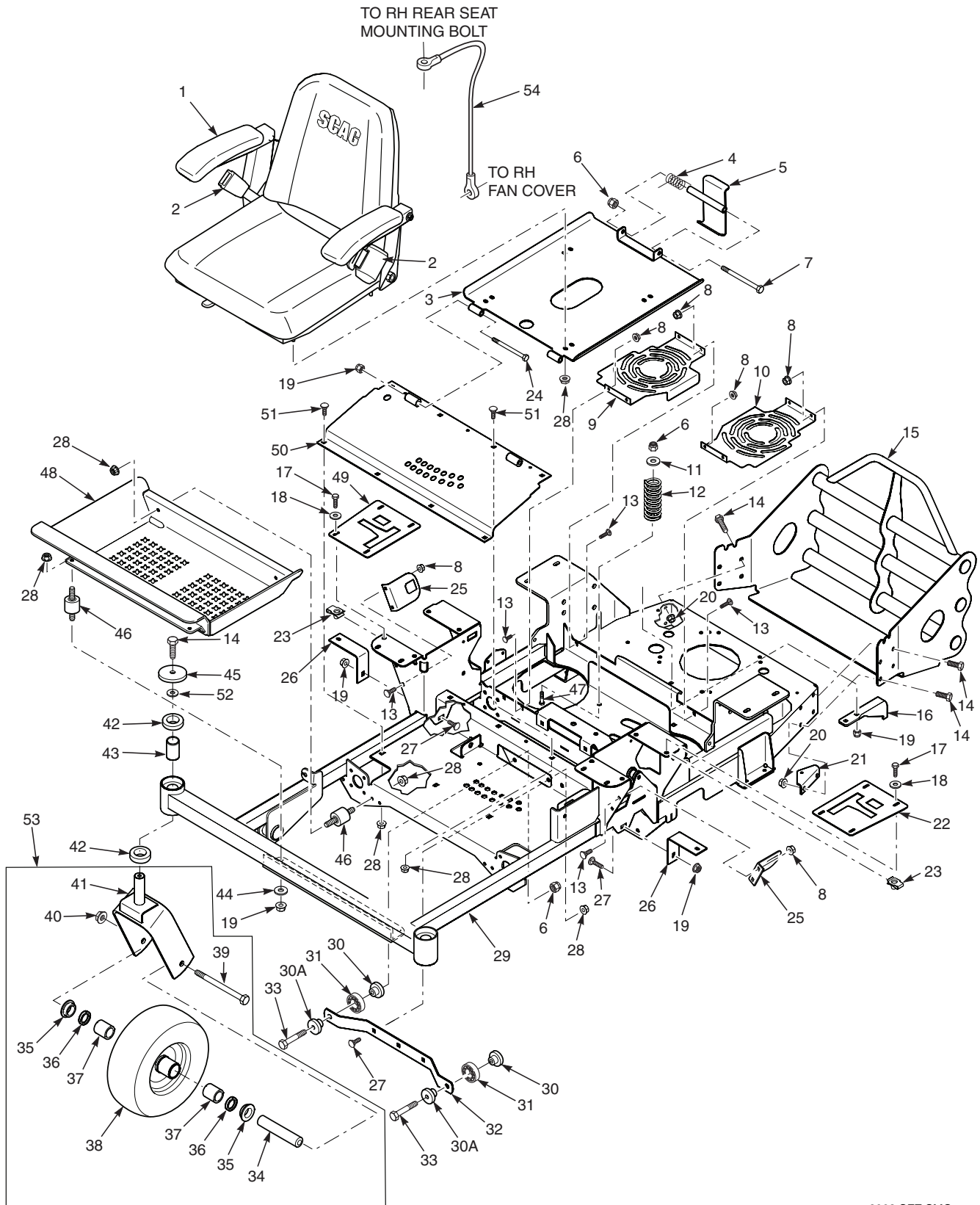

SHEET METAL COMPONENTS

	Part No.	Description	36	48 52	61	Ref. No.	Part No.	Description	36	48 52	61
1	483408	Seat Assembly	x	x	x	27	04003-12	Bolt, Carriage 5/16-18 x 3/4"	x	x	x
	483544	Back Cushion	x	x	x	28	04019-03	Nut, Serrated Flange 5/16-18	x	x	x
	483545	Bottom Cushion	x	x	x	29	462131	Main Frame w/Decals	x		
	483549	Arm Rest Kit	x	x	x		462022	Main Frame w/Decals		x	
	483543	Seat Adjustment Kit	x	x	x		462214	Main Frame w/Decals			x
2	483412	Seat Belt Assembly, Retractable	x	x	x	30	43719	Spacer, Bearing	x		
	461990	Hardware Package, Mounting	x	x	x		43703	Spacer, Bearing		x	x
3	462034	Seat Base w/Decal	x	x	x	30A	43719	Spacer, Bearing (SFZ36 Only)			
4	483371	Spring, Seat Latch	x	x	x		04041-07	Flatwasher, 3/8-.391 x .938 x .105	x		
5	451883	Seat Latch	x	x	x	31	483379	Bearing	x		x
6	04021-09	Nut, Elastic Stop 3/8-16	x	x	x	32	424480	Support, Deck Guide	x	x	x
7	04001-100	Bolt, Hex Head 3/8-16 x 6"	x	x	x	33	04001-21	Bolt, Hex Head 3/8-16 x 1-3/4"		x	
8	04019-02	Nut, Serrated Flange 1/4-20	x	x	x		04001-31	Bolt, Hex Head 3/8-16 x 2-1/2"	x		x
9	424829	Cover, Fan RH	x			34	43698	Sleeve, Front Caster Wheel		x	x
	424585	Cover, Fan RH		x	x	35	483453-09	Bearing	x	x	x
10	424828	Cover, Fan LH	x			36	483486	Seal, 1 x 1.375 x .25	x	x	x
	424550	Cover, Fan LH		x	x	37	483453-08	Bearing	x	x	x
11	04041-07	Flatwasher, 3/8-.391 x .938 x .105	x	x	x	38	483409	Caster Wheel Assembly	x	x	x
12	483372	Spring, Seat	x	x	x		483417	Tire, 11 x 4-5.00 2-Ply	x	x	x
13	04003-07	Bolt, Carriage 1/4-20 x 1"	x	x	x		483410	Rim, 5 x 3.25 w/Valve	x	x	x
14	04001-19	Bolt, Hex Head 3/8-16 x 1"	x	x	x	39	04001-80	Bolt, Hex Head 1/2-13 x 6-1/2"	x	x	x
15	451995	Rear Bumper	x			40	04021-07	Nut, Elastic Stop 1/2-13	x	x	x
	451929	Rear Bumper		x	x	41	451845	Yoke, Caster Wheel	x	x	x
	483535	Plug, Bumper Tube (not shown)	x	x	x	42	483466	Bearing	x	x	x
16	424792	Bracket, Anti-Rotation	x				424636	Spacer, Yoke (not shown)	x	x	x
	424523	Bracket, Anti-Rotation		x		43	43736	Spacer, Caster Bearing	x	x	x
	425328	Bracket, Anti-Rotation			x	44	04040-15	Flatwasher, 5/16-.375 x .875 x .083	x	x	x
17	04001-14	Bolt, Hex Head 1/4-20 x 1"	x	x	x	45	04041-38	Flatwasher, 3/8-.406 x 2.25 x .188	x	x	x
18	04040-14	Flatwasher, 1/4-.312 x .750 x .065	x	x	x	46	483493	Rubber Isolator	x	x	x
19	04021-10	Nut, Elastic Stop 5/16-18	x	x	x	47	04003-11	Bolt, Carriage 3/8-16 x 1-1/4"	x	x	
20	04019-04	Nut, Serrated Flange 3/8-16	x	x	x	48	451889	Footplate Weldment			x
21	424639	Bracket, Dump Valve	x	x	x		452104	Footplate Weldment (61 Only)	x	x	
22	462129	Control Plate LH	x			49	462130	Control Plate RH	x		x
	462023	Control Plate LH		x	x		462024	Control Plate RH		x	x
23	04110-01	U-Nut 1/4-20	x	x	x	50	462005	Weldment, Deck Lift Cover	x	x	x
24	04001-73	Bolt, Hex Head 5/16-18 x 3-3/4"	x	x	x	51	04003-14	Bolt, Carriage 5/16-18 x 1/2"	x	x	x
25	424511	Bracket, Switch Mount	x	x	x	52	04040-11	Flatwasher, 7/16-.50 x 1.250 x .083	x	x	x
26	424516	Bracket, Tank Mount	x	x	x	53	462015	Caster Wheel Assembly w/Yoke	x	x	x
						54	483559	Cable, Seat Stop	x	x	x

SFZ ROLL-OVER PROTECTION SYSTEM

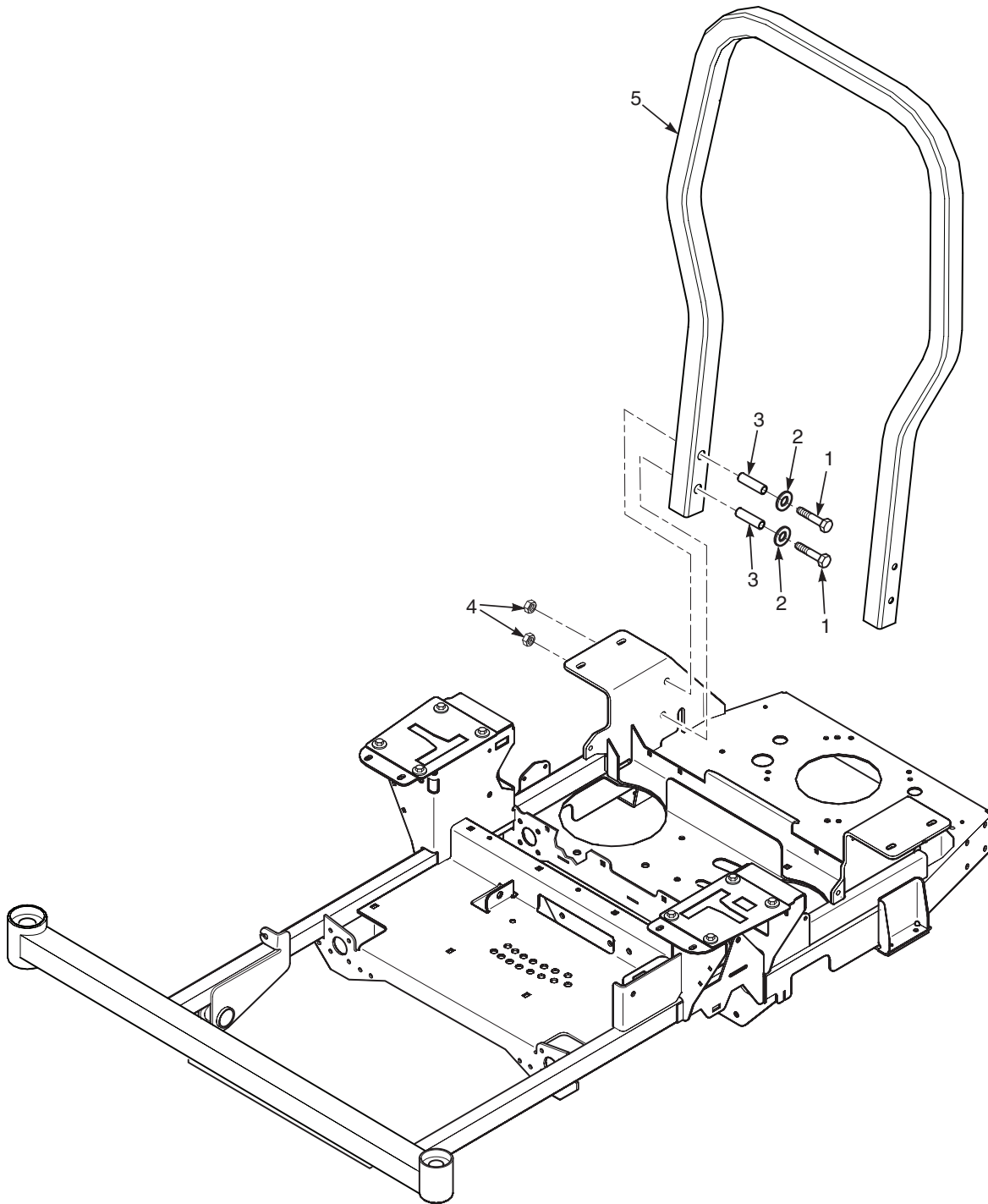

SFZ ROLL-OVER PROTECTION SYSTEM

Ref. No.	Part No.	Description
1	04001-184	Bolt, Hex Head 1/213 x 3-1/4" Gr. 8
2	04040-13	Flatwasher, 1/2 - .562 x 1.375 x .109
3	43743	Bushing, SFZ ROPS
4	04117-04	Nut, Flanged Elastic Stop, 1/2-13
5	462106	ROPS, SFZ36
	462021	ROPS, SFZ48, SFZ52 & SFZ61

DRIVE SYSTEM COMPONENTS - SFZ36

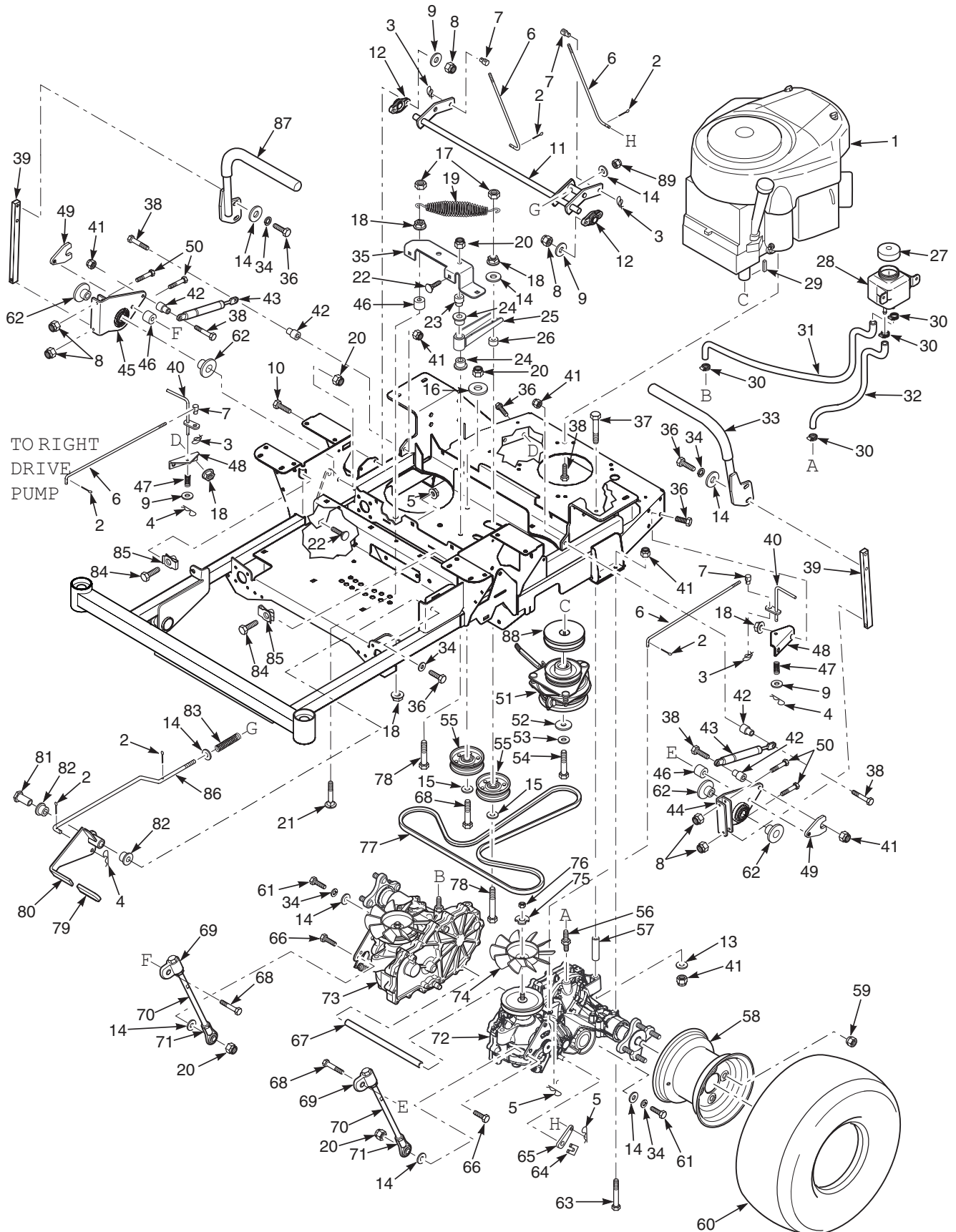

DRIVE SYSTEM COMPONENTS - SFZ36

Ref. No.	Part No.	Description
1	483707	Engine, Briggs & Stratton 20hp
	483706	Engine, Kawasaki 17hp
2	04061-01	Cotter Pin, 3/32 x 1"
3	04069-01	Pin, Rue Cotter 3/8" Dia.
4	04062-02	Hair Pin, .080 x 1.19"
5	04019-03	Nut, Serrated Flange 5/16-18
6	44162	Rod, Brake Adjustment
7	43726	Joint, Swivel
8	04021-08	Nut, Elastic Stop 1/4-20
9	04040-14	Flatwasher, 1/4-.312 x .750 x .065
10	04017-07	Bolt, Serrated Flange 1/4-20 x 1-1/4"
11	451998	Weldment, Brake Lever
12	483504	Bearing
13	04040-15	Flatwasher, 5/16-.375 x .875 x .083
14	04041-07	Flatwasher, 3/8-.391 x .938 x .105
15	04043-04	Flatwasher, 3/8-.391 x .938 x .105 HD
16	04041-11	Flatwasher, 3/8-.406 x 1.5 x 7 GA.
17	04021-05	Nut, Center Lock 3/8-16
18	04019-04	Nut, Serrated Flange 3/8-16
19	483087	Spring, Transmission Idler
20	04021-09	Nut, Elastic Stop 3/8-16
21	04003-03	Bolt, Carriage 3/8-16 x 2"
22	04003-12	Bolt, Carriage 5/16-18 x 3/4"
23	43715	Shaft Pivot, Idler Arm
24	483453-04	Bearing
25	462122	Transmission Idler Arm Assembly
26	43720	Spacer, Idler Pulley
27	483514	Cap
28	483438	Reservoir Assembly
29	04063-31	Key, 1/4 x 1/4 x 1-3/4"
30	48136-05	Clamp, 0.87" Max Dia.
31	483431	Hose, RH Transmission
32	483698	Hose, LH Transmission
33	462001	Handle Bar Assembly, w/Grip
	482340	Grip
34	04030-04	Lockwasher, 3/8" Spring
35	424827	Support, Idler Arm
36	04001-19	Bolt, Hex Head 3/8-16 x 1"
37	04001-191	Bolt, Hex Head 5/16-18 x 6"
38	04001-11	Bolt, Hex Head 5/16-18 x 1-1/2"
39	424498	Bar, Control Lever
40	451912	Dump Valve Lever
41	04021-10	Nut, Elastic Stop 5/16-18
42	43602	Spacer, Pump Dampener
43	482794	Dampener
44	462127	Control Link, LH
45	462128	Control Link, RH

Ref. No.	Part No.	Description
46	43674	Spacer
47	482070	Spring
48	424639	Bracket, Dump Mounting
49	424687	Nut, Control Linkage
50	04001-04	Bolt, Hex Head 1/4-20 x 1-1/2"
51	462012	Electric Clutch Assembly
52	04041-28	Flatwasher, 7/16-.469 x 1.75 x .25
53	04030-05	Lockwasher, 7/16" spring
54	04102-03	Bolt, Hex Head 7/16-20 x 2-1/4" Patch
55	483638	Pulley, 3-1/2" Dia.
56	482800-04	Fitting, Transmission
57	43765	Spacer, Axle
58	483658	Rim w/Valve Stem
59	04028-02	Wheel Nut, 1/2-20
60	483657	Wheel Assembly
	483659	Tire, 18 x 7-8 4-Ply
61	04001-46	Bolt, Hex Head 3/8-16 x 2-1/4"
62	43719	Spacer, Linkage
63	04001-39	Bolt, Hex Head 5/16-18 x 2-1/4"
64	HG51190	Clip, Brake Lever (order through Hydro-Gear)
65	HG52639	Lever, Brake (order through Hydro-Gear)
66	04001-32	Bolt, Hex Head 3/8-16 x 1-1/4"
67	43766	Spacer, Axle
68	04001-45	Bolt, Hex Head 3/8-16 x 2"
69	483563	Rod End, Adjustable
	04020-25	Nut, Jam 3/8-24 UNF RH
70	483668	Linkage, Pump
71	483682	Stake, Rod End Assembly
72	483663	Transaxle Assy., (ZJ-KMEF-3LKG-1FXX)
73	483664	Transaxle Assy., (ZJ-GMEF-3LKF-1FXX)
74	HG52476	Fan (order through Hydro-Gear)
75	HG51523	Fan Washer (order through Hydro-Gear)
76	HG51244	Fan Nut (order through Hydro-Gear)
77	483666	Belt, TRansmission Drive
78	04001-54	Bolt, Hex Head 3/8-16 x 3"
79	482102	Grip, Brake Handle
80	462010	Brake Handle Assembly
81	43722	Spacer, Brake Handle
82	483453-05	Bearing
83	483538	Spring, Brake
84	04107-01	Bolt, Hex Head 3/8-16 x 1-1/4" Special Lock
85	04110-03	U-Nut, 3/8-16
86	44164	Rod, Brake Linkage
87	462000	Handle Bar w/Grip
	482340	Grip
88	483670	Pulley, 4-1/2" Dia. 1" Bore
89	04021-18	Nut, Elastic Stop 3/8-24 Gr. 8

DRIVE SYSTEM COMPONENTS - SFZ48, SFZ52 & SFZ61

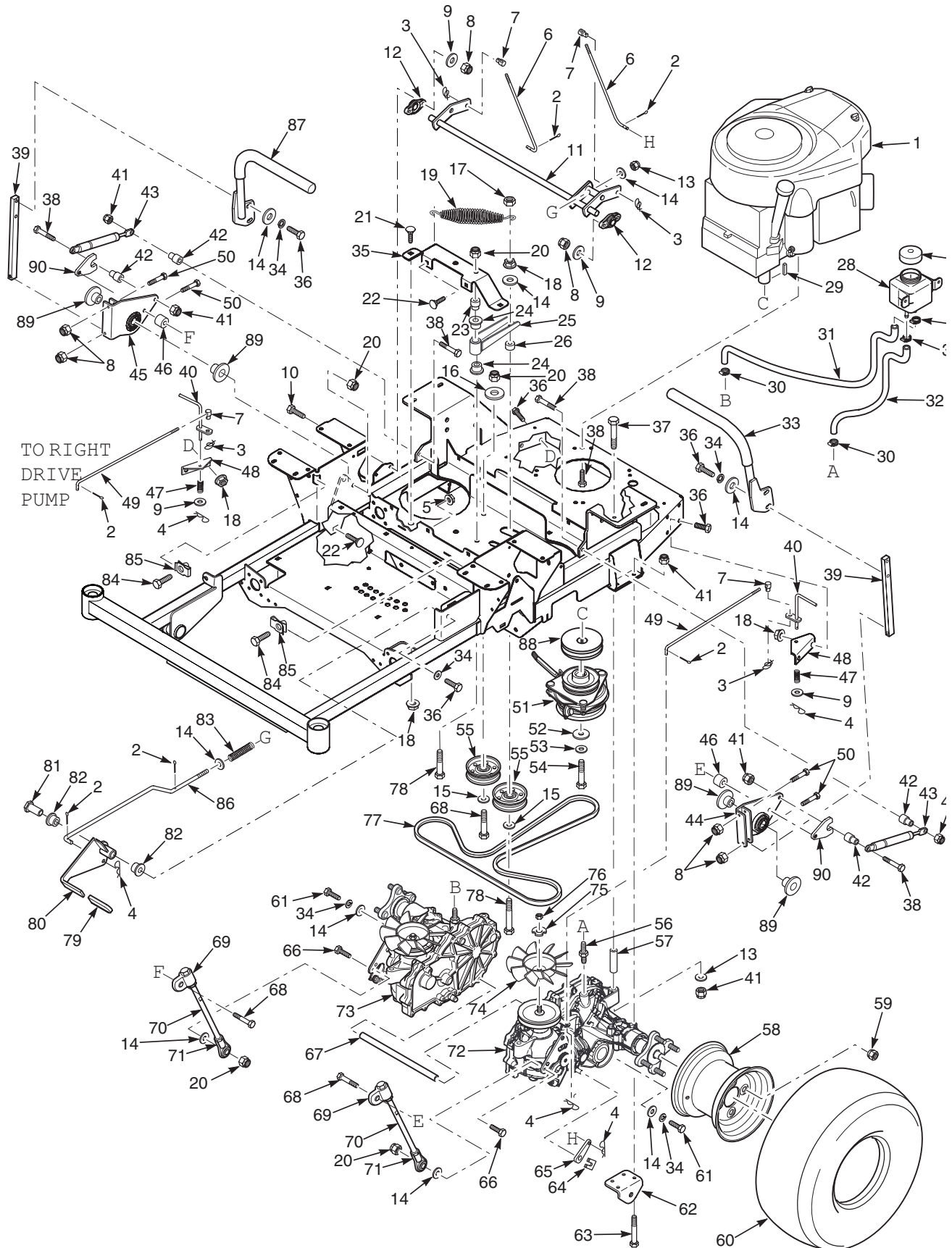

DRIVE SYSTEM COMPONENTS - SFZ48, SFZ52 & SFZ61

Ref. No.	Part No.	Description
1	483465	Engine, Briggs & Stratton 26hp
	483516	Engine, Kawasaki 19hp
	484133	Engine, Briggs & Stratton 28hp (61 Only)
2	04061-01	Cotter Pin, 3/32 x 1"
3	04069-01	Pin, Rue Cotter 3/8" Dia.
4	04062-02	Hair Pin, .080 x 1.19"
5	04019-03	Nut, Serrated Flange 5/16-18
6	44165	Rod, Brake Adjustment
7	43726	Joint, Swivel
8	04021-08	Nut, Elastic Stop 1/4-20
9	04040-14	Flatwasher, 1/4-.312 x .750 x .065
10	04017-07	Bolt, Serrated Flange 1/4-20 x 1-1/4"
11	451884	Weldment, Brake Lever
12	483504	Bearing
13	04040-15	Flatwasher, 5/16-.375 x .875 x .083
14	04041-07	Flatwasher, 3/8-.391 x .938 x .105
15	04043-04	Flatwasher, 3/8-.391 x .938 x .105 HD
16	04041-11	Flatwasher, 3/8-.406 x 1.5 x 7 GA.
17	04021-05	Nut, Center Lock 3/8-16
18	04019-04	Nut, Serrated Flange 3/8-16
19	483087	Spring, Transmission Idler
20	04021-09	Nut, Elastic Stop 3/8-16
21	04003-31	Bolt, Carriage 3/8-16 x 3/4"
22	04003-12	Bolt, Carriage 5/16-18 x 3/4"
23	43715	Shaft Pivot, Idler Arm
24	483453-04	Bearing
25	462122	Transmission Idler Arm Assembly
26	43720	Spacer, Idler Pulley
27	483514	Cap
28	483438	Reservoir Assembly
29	04063-31	Key, 1/4 x 1/4 x 1-3/4"
	04063-02	Key, 1/4 x 1/4 x 2-1/4" - SFZ-61 Only
30	48136-05	Clamp, 0.87" Max Dia.
31	483431	Hose, RH Transmission
32	483432	Hose, LH Transmission
33	462001	Handle Bar Assembly, w/Grip
	482340	Grip
34	04030-04	Lockwasher, 3/8" Spring
35	424476	Support, Idler Arm
36	04001-19	Bolt, Hex Head 3/8-16 x 1"
37	04001-95	Bolt, Hex Head 5/16-18 x 5"
38	04001-11	Bolt, Hex Head 5/16-18 x 1-1/2"
39	424498	Bar, Control Lever
40	451912	Dump Valve Lever
41	04021-10	Nut, Elastic Stop 5/16-18
42	43602	Spacer, Pump Dampener
43	482794	Dampener
44	462127	Control Link, LH
45	462128	Control Link, RH
46	43674	Spacer
47	482070	Spring
48	424639	Bracket, Dump Mounting

Ref. No.	Part No.	Description
49	44162	Linkage, Dump Valve
50	04001-04	Bolt, Hex Head 1/4-20 x 1-1/2"
51	462012	Electric Clutch Assembly (48, 52)
	462228	Electric Clutch Assembly (61)
52	04041-28	Flatwasher, 7/16-.469 x 1.75 x .25 (48, 52)
	43832	Spacer, Crankshaft, SFZ-61 (repl. 04041-28)
53	04030-05	Lockwasher, 7/16" spring
54	04102-03	Bolt, Hex Head 7/16-20 x 2-1/4" Patch
	04102-08	Bolt, Hex Head 7/16-20 x 1-1/2" Patch SFZ-61
55	483638	Pulley, 3-1/2" Dia.
56	482800-04	Fitting, Transmission
57	43700	Spacer, Axle
58	481868	Rim w/Valve Stem (48, 52, 61)
59	04028-02	Wheel Nut, 1/2-20
60	483390	Wheel Assembly (48, 52)
	483389	Tire, 20 x 10-8 2-Ply (48, 52, 61)
	484056	Wheel Assembly (61)
61	04001-46	Bolt, Hex Head 3/8-16 x 2-1/4"
62	424489	Bracket, Pusharm Link
63	04001-49	Bolt, Hex Head 5/16-18 x 3"
64	HG51190	Clip, Brake Lever (order through Hydro-Gear)
65	HG52639	Lever, Brake (order through Hydro-Gear)
66	04001-32	Bolt, Hex Head 3/8-16 x 1-1/4"
67	43701	Spacer, Axle
68	04001-45	Bolt, Hex Head 3/8-16 x 2"
69	483563	Rod End, Adjustable
	04020-25	Nut, Jam 3/8-24 UNF RH
70	483574	Linkage, Pump
71	483575	Stake, Rod End Assembly
72	483527	Transaxle Assy., (ZL-KCEF-3LKG-1EXX)
	484064	Transaxle Assy., (ZU-KCEE-3LKG-12XX) - SFZ61
73	483528	Transaxle Assy., (ZL-GCEF-3LKF-1EXX)
	484065	Transaxle Assy., (ZU-GCEE-3LKF-12XX) - SFZ61
74	HG51862	Fan (order through Hydro-Gear)
75	HG51523	Fan Washer (order through Hydro-Gear)
76	HG44133	Fan Nut (order through Hydro-Gear)
77	483314	Belt, TRansmission Drive
78	04001-54	Bolt, Hex Head 3/8-16 x 3"
79	482102	Grip, Brake Handle
80	462010	Brake Handle Assembly
81	43722	Spacer, Brake Handle
82	483453-05	Bearing
83	483538	Spring, Brake
84	04107-01	Bolt, Hex Head 3/8-16 x 1-1/4" Special Lock
85	04110-03	U-Nut, 3/8-16
86	44157	Rod, Brake Linkage
87	462000	Handle Bar w/Grip
	482340	Grip
88	483320	Pulley, 4-1/2" Dia. 1" Bore
	484071	Pulley, 4-1/2" Dia. 1.125" Bore
89	43719	Spacer, Linkage
90	424687	Nut, Control Linkage

FUEL AND ELECTRICAL SYSTEM - SFZ36

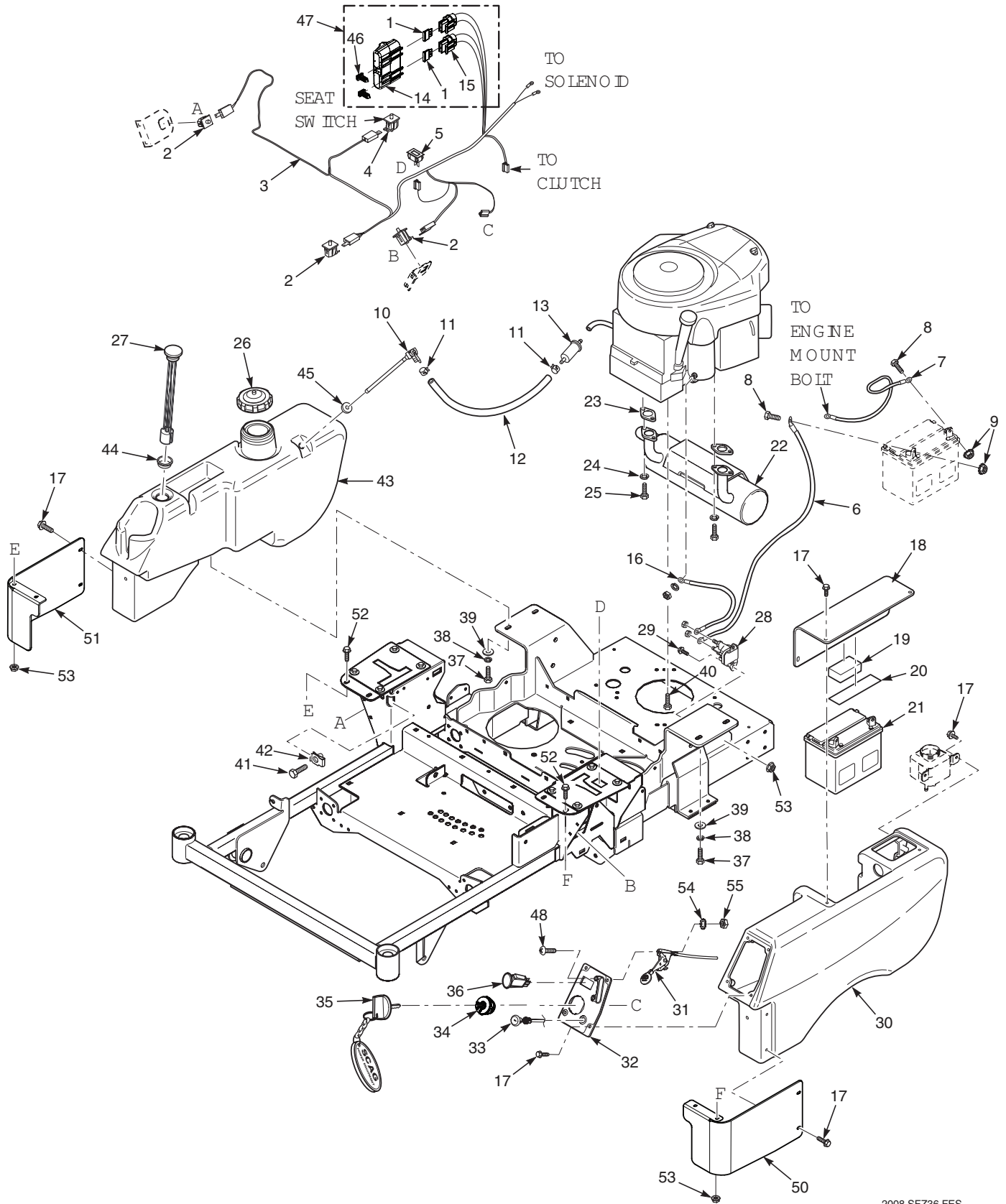

FUEL AND ELECTRICAL SYSTEM - SFZ36

Ref. No.	Part No.	Description
1	48298	Fuse, 20 amp
2	483473	Switch
3	483621	Wire Harness, Main
4	483474	Switch, Seat
5	483537	Hourmeter
6	48029-13	Battery Cable, Red 25"
7	48029-11	Battery Cable, Black 27"
8	04001-44	Bolt, Hex Head 1/4-20 x 1/2"
9	04020-02	Nut, 1/4-20
10	483557	Fuel Tube Assembly
11	48059-01	Clamp, Fuel Hose 1/4" ID
12	483617	Fuel Hose, 1/4" ID Non-Perm (order by inch)
13	**	Fuel Filter
14	483571	Cover, Sealed Double
15	483629	Fuse Holder
16	48029-09	Battery Cable, Red 9"
17	04017-04	Bolt, Hex Head 1/4-20 x 1/2" Serr. Flange
18	461996	Battery Cover (incl. items 19 & 20)
19	483452	Pad, Battery Hold Down
20	483508	Rubber Pad
21	483665	Battery (not avail. through Scag)
22	483381	Muffler, Briggs & Stratton
	483383	Muffler, Kawasaki
23	**	Exhaust Gasket
24	**	Lockwasher
25	**	Bolt
26	483792	Cap, Fuel Tank
27	483523	Fuel Gauge Assembly
28	483278	Solenoid
29	04001-03	Bolt, Hex Head 1/4-20 x 0.63"

Ref. No.	Part No.	Description
30	483672	Tank, LH
31	483434	Throttle Cable, Briggs & Stratton
	483645	Throttle Cable, Kawasaki
32	462136	Instrument Panel w/Decal
33	483435	Choke Cable, Briggs & Stratton
	483646	Choke Cable, Kawasaki
34	483472	Ignition Switch
35	483366	Key, Ignition
	483609	Key w/Shroud
	462069	Key Assembly w/Fob
36	483957	PTO Switch
37	04001-08	Bolt, Hex Head 5/16-18 x 3/4"
38	04030-03	Lockwasher, 5/16" Spring
39	04040-15	Flatwasher, 5/16-.375 x .875 x .083
40	04001-11	Bolt, Hex Head 5/16-18 x 1-1/2"
41	04107-03	Bolt, Hex Head 3/8-16 x 1-1/4" Special Lock
42	04110-03	U-Nut, 3/8-16
43	462099	Fuel Tank Assembly, RH
44	483536	Grommet
45	482571	Bushing, 0.56" Dia. Viton
46	482588	Clip, Wire
47	483642	Double Fuse Assy. (incl. items 1, 14, 15, 46)
48	04010-12	Screw, #10-32 X 3/4"
49	04019-01	Nut, Serrated Flange #10-32
50	424830	Control Cover, LH
51	424822	Control Cover, RH
52	04017-05	Bolt, Hex Head 1/4-20 x 3/4" Serr. Flange
53	04019-02	Nut, Serrated Flange 1/4-20
54	04031-01	Lockwasher, #10 External Tooth
55	04020-01	Nut, Hex #10-32

** Available through individual engine manufacturer.

FUEL AND ELECTRICAL SYSTEM - SFZ48, SFZ52 & SFZ61

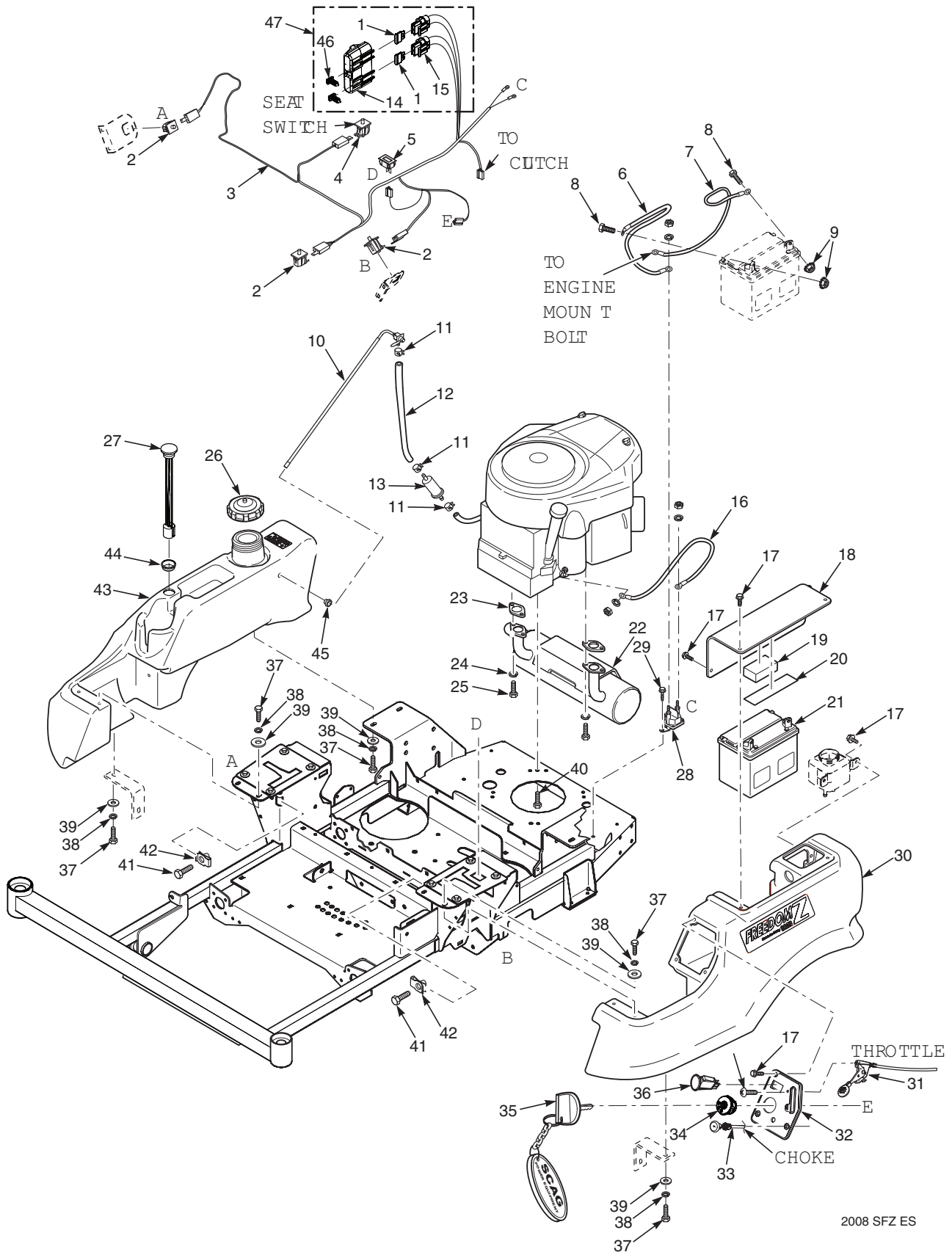

FUEL AND ELECTRICAL SYSTEM - SFZ48, SFZ52 & SFZ61

Ref. No.	Part No.	Description
1	48298	Fuse, 20 amp
2	483473	Switch
3	483621	Wire Harness, Main
4	483474	Switch, Seat
5	483537	Hourmeter
6	48029-13	Battery Cable, Red 25"
7	48029-11	Battery Cable, Black 27"
8	04001-44	Bolt, Hex Head 1/4-20 x 1/2"
9	04020-02	Nut, 1/4-20
10	483555	Fuel Tube Assembly
11	48059-01	Clamp, Fuel Hose 1/4" ID
12	483617	Fuel Hose, 1/4" ID Non-Perm (order by inch)
13	**	Fuel Filter
14	483571	Cover, Sealed Double
15	483629	Fuse Holder
16	48029-09	Battery Cable, Red 9"
17	04017-04	Bolt, Hex Head 1/4-20 x 1/2" Serr. Flange
18	461996	Battery Cover (incl. items 19 & 20)
19	483452	Pad, Battery Hold Down
20	483508	Rubber Pad
21	483665	Battery (not avail. through Scag)
22	483381	Muffler, Briggs & Stratton
	483383	Muffler, Kawasaki
23	**	Exhaust Gasket
24	**	Lockwasher
25	**	Bolt
26	483792	Cap, Fuel Tank
27	483523	Fuel Gauge Assembly
28	483278	Solenoid
29	04011-13	Bolt, Self Tapping 1/2-20 x 3/4" Shakeproof

Ref. No.	Part No.	Description
30	483364	Tank, LH
31	483434	Throttle Cable, Briggs & Stratton
	483645	Throttle Cable, Kawasaki
32	462036	Instrument Panel w/Decal
33	483435	Choke Cable, Briggs & Stratton
	483646	Choke Cable, Kawasaki
34	483472	Ignition Switch
35	483366	Key, Ignition
	483609	Key w/Shroud
	462069	Key Assembly w/Fob
36	483957	PTO Switch
37	04001-08	Bolt, Hex Head 5/16-18 x 3/4"
38	04030-03	Lockwasher, 5/16" Spring
39	04040-15	Flatwasher, 5/16-.375 x .875 x .083
40	04001-11	Bolt, Hex Head 5/16-18 x 1-1/2"
41	04107-03	Bolt, Hex Head 3/8-16 x 1-1/4" Special Lock
42	04110-03	U-Nut, 3/8-16
43	462009	Fuel Tank Assembly, RH
44	483536	Grommet
45	482571	Bushing, 0.56" Dia. Viton
46	482588	Clip, Wire
47	483642	Double Fuse Assy. (incl. items 1, 14, 15, 46)

** Available through individual engine manufacturer.

ZT-3100 HYDRAULIC AXLE ASSEMBLY

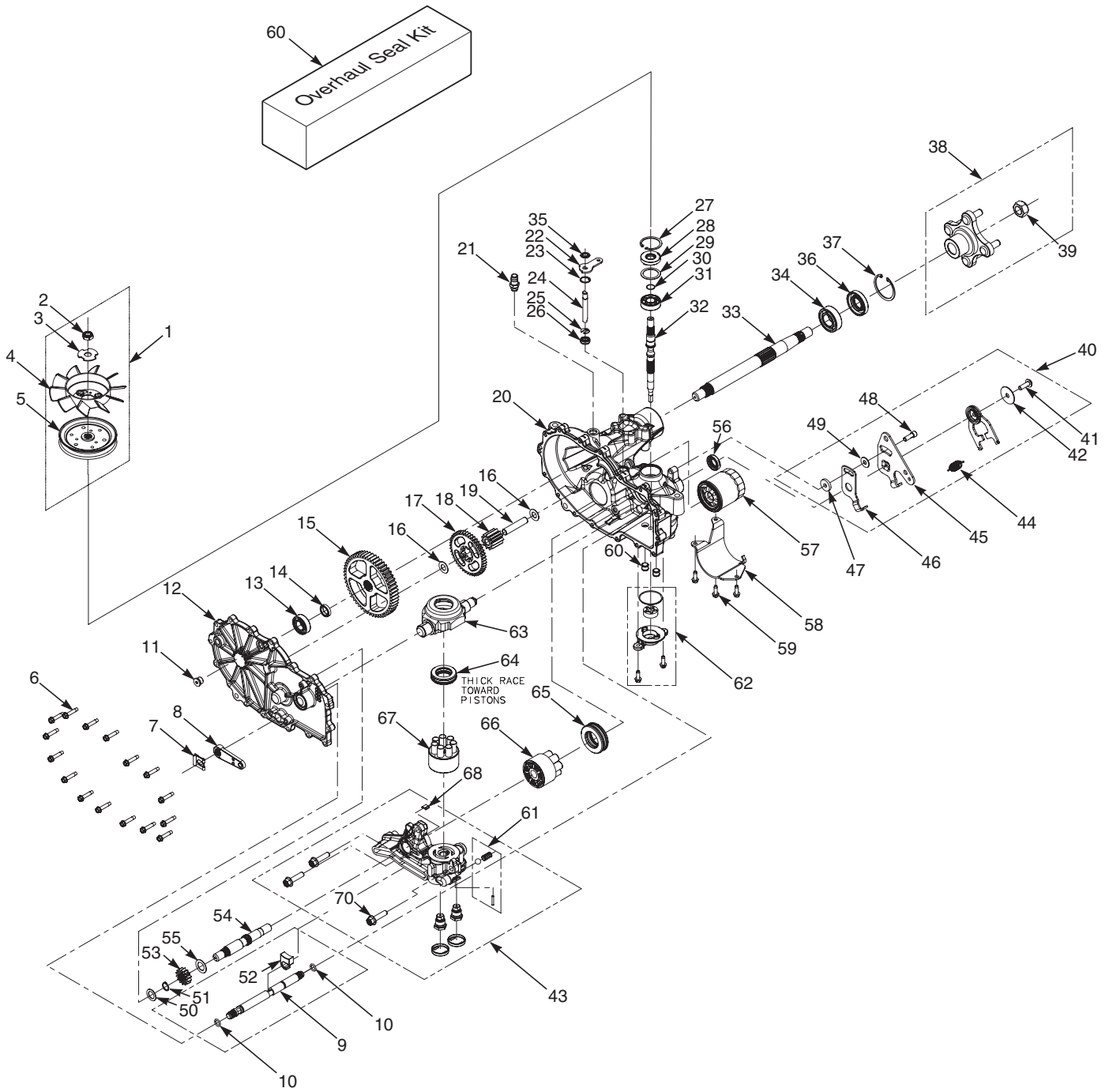

ZT-3100 HYDRAULIC AXLE ASSEMBLY

Ref. No.	Part No.	Description
1	HG71512	Kit, Fan & Pulley (SFZ36)
	HG70489	Kit, Fan & Pulley
2	HG51244	Nut, Hex Locking 1/2-20
3	HG51523	Washer, Slotted
4	HG52576	Fan, 7" Dai. (10 Blade) - (SFZ36)
	HG51862	Fan, 7" Dai. (10 Blade)
5	HG50302	Pulley, Cupped 4-1/2" Dia (SFZ36)
	HG52364	Pulley, Cupped 4-1/2" Dia
	HG52366	Hub, Pulley
6	HG51190	Bolt, Hex Head 1/4-20 x 1-11/4"
7	HG52027	Clip, Retaining
8	HG52639	Handle, Brake
9	HG52640	Shaft, Brake
10	HG51804	O-Ring
11	HG9005110-5600	Plug, 9/16-18
12	HG71572	Kit, Side Cover RH
	HG71574	Kit, Side Cover LH
13	HG44121	Bearing, Ball .75 x 40 x 12
14	HG52161	Spacer, .75 x 1.0 x .257
15	HG52108	Gear, 54T
16	HG50132	Washer, .5 x 1.0 x .03
17	HG52148	Gear, 43T (SFZ36)
	HG52110	Gear, 45T
18	HG52586	Gear, 11T
19	HG51083	Jackshaft Pin
20	HG71413	Kit, Housing RH
	HG71421	Kit, Housing LH
21	482800-03	Fitting
22	HG51329	Arm, By-Pass
23	HG51627	Ring, Retaining .750 Internal
24	HG52136	Rod, By-Pass
25	HG51628	Ring, .Retaining .375 External
26	HG51626	Seal, Lip .375 x .75 x .25
27	HG50329	Ring, Retaining 2.06 Internal
28	HG51161	Seal, Lip 17 x 40 x 7
29	HG50951	Washer, 1.23 x 1.56 x .04
30	HG2000022	Ring, Retaining Wire
31	HG50315	Bearing, Ball 17 x 40 x 12 Open
32	HG52155	Shaft, Input
33	HG71570	Shaft Kit, Axle (SFZ36)
	HG71569	Shaft Kit, Axle
34	HG50771	Bearing, Ball 1.0 x 52 x 15 Open
35	HG51630	Ring, Retaining .375 External

Ref. No.	Part No.	Description
36	HG50772	Seal, Lip 25 x 52 x 10 TC Gray
37	HG50859	Ring, Retaining 2.06 Internal
38	HG71446	Hub Kit (SFZ36)
	HG71505	Hub Kit
39	HG50863	Nut, Hex Locking
40	HG71595	Kit, RTN Assembly
41	HG51812	Bolt, 5/16-24 x 1" Patch
42	HG51950	Washer, .343 x 1.5 x .062
43	HG71565	Kit, Center Section RH
	HG71566	Kit, Center Section LH
44	HG51605	Spring
45	HG52682	Arm, Control
46	HG51945	Arm, Neutral RH
	HG51946	Arm, Neutral LH
47	HG52527	Spacer, .320 x 1.005 x .179
48	HG51616	Bolt, 5/16-24 x 1" Patch
49	HG44130	Washer, .34 x .88 x .06
50	HG44371	Washer, .63 x 1.0 x .05
51	HG44145	Ring, Retaining
52	HG52641	Pawl, Brake
53	HG52344	Gear, 16T (SFZ36)
	HG52341	Gear, 14T
54	HG52150	Shaft, Motor
55	HG51069	Washer, .72 x 1.16 x .04
56	HG51140	Seal, Lip 18 x 32 x 7
57	HG52114	Filter
58	HG52257	Filter Guard
59	HG50752	Bolt, 1/4-20 x 3/4"
60	HG71410	Seal Kit
61	HG71436	Kit, Charge Relief
62	HG71411	Kit, Charge Pump
63	HG51048	Trunnion Washplate
64	HG50551	Thrust Bearing
65	HG51462	Thrust Bearing
66	HG71579	Kit, Motor Cylinder Block
67	HG70723	Kit, Cylinder Block
68	HG71448	Plate, By-Pass
69	HG71436	Kit, Charge Relief
70	HG52137	Bolt, Hex Head 3/8-16 x 1-1/2" Patch

ZT-3400 HYDRAULIC AXLE ASSEMBLY -SFZ61

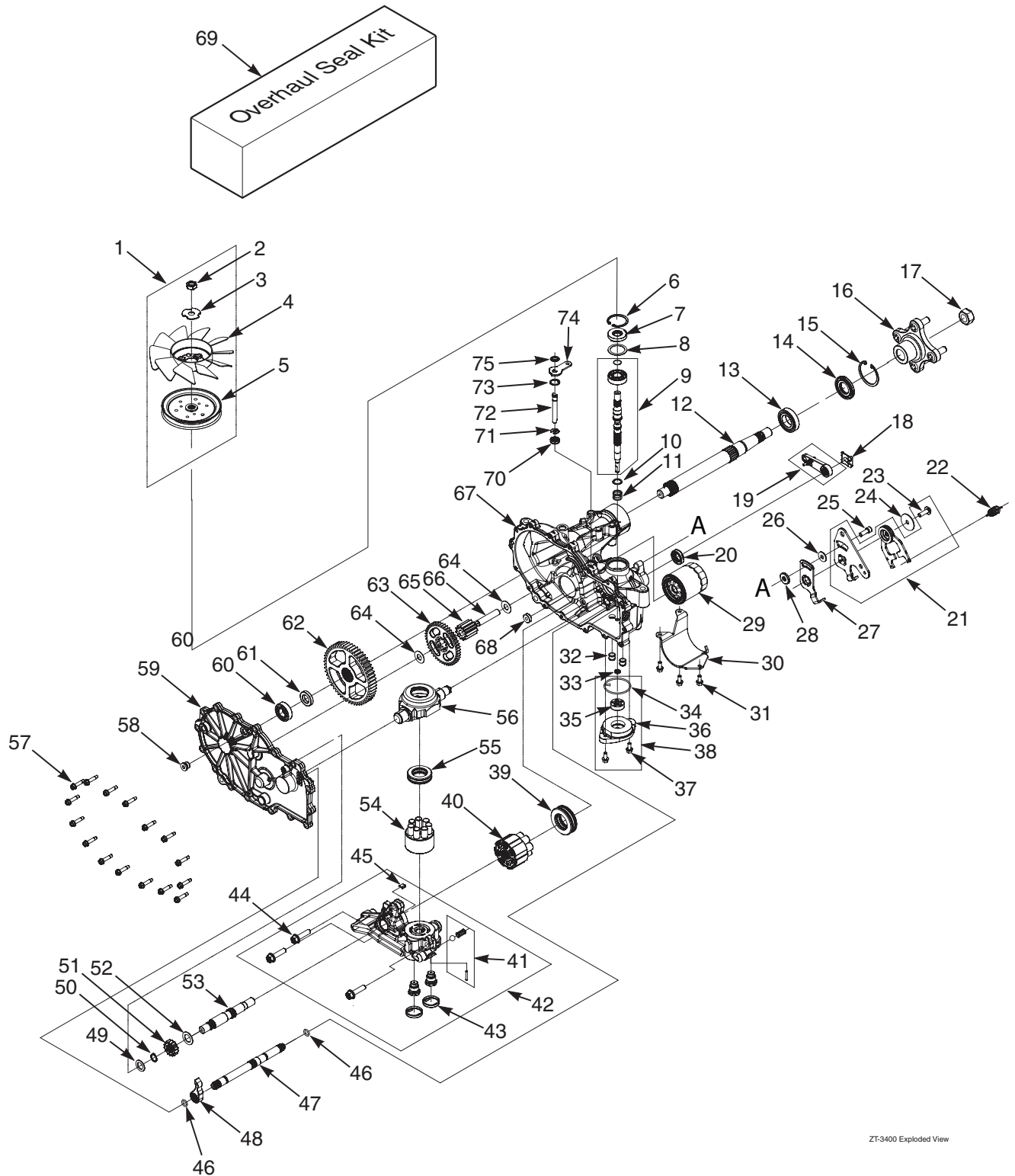

ZT-3400 Exploded View

ZT-3400 HYDRAULIC AXLE ASSEMBLY - SFZ61

Ref. No.	Part No.	Description
1	HG72034	Kit, Fan & Pulley
2	HG44133	Nut, Elastic Stop 1/2-20
3	HG51523	Washer, OD Slotted .53 x 1.63 x .06
4	HG51862	Fan, 7" (10 Blade)
5	HG53619	Pulley, 4-1/2"
6	HG53029	Ring, Retaining
7	HG51161	Seal, Lip 17 x 40 x 7
8	HG50951	Washer, 1.23 x 1.56 x .04
9	HG71978	Kit, Input Shaft
10	HG2003017	Washer, Flat .59 x .79 x .04
11	HG2003014	Spring, Block
12	HG53528	Shaft, Axle
13	HG50771	Bearing, Ball 25.4 x 52 x 15
14	HG50772	Seal, Lip 1 x 2.049 x .375
15	HG50859	Ring, Retaining 2.06 Internal
16	HG71405	Hub, 4-Bolt
17	HG50863	Nut, Hex Lock 3/4-16
18	HG52027	Clip, Retaining
19	HG52639	Handle, Brake Actuating
20	HG51140	Seal, Lip 12 x 32 x 7
21	HG71595	Kit, RTN Bi-Directional (Left Side)
	HG71598	Kit, RTN Bi-Directional (Right Side)
22	HG51605	Spring, RTN
23	HG51812	Bolt, Hex Head Cap Screw 5/16-24 x 1" Patch
24	HG51950	Washer, .343 x 1.5 x .062
25	HG51616	Bolt, Hex Head Cap Screw 5/16-24 x 1" Patch
26	HG44130	Washer, .34 x .88 x .06
27	HG51945	Arm, Neutral (Right Side)
	HG51946	Arm, Neutral (Left Side)
28	HG52527	Spacer, .320 x 1.005 x .179
29	HG52114	Filter, Oil
30	HG52257	Guard, Filter (Right Side)
	HG52247	Guard, Filter (Left Side)
31	HG53464	Screw, Hex Flange 1/4-20 x .625
32	HG52157	Tibe, Connecting
33	HG53456	Seal, Lip 8 x 12 x 3-VC
34	HG52250	O-Ring, -.137 x .103 x 2.050
35	HG50273	Gerotor Assembly (1.9 cc)
36	HG53468	Cover, Charge Pump
37	HG53464	Screw, Hex Flange 1/4-20 x .625
38	HG71977	Kit, Charge Pump
39	HG51462	Bearing, Thrust

Ref. No.	Part No.	Description
40	HG71579	Assembly, Cylinger Block
41	HG71436	Kit, Charge Relief
42	HG71972	Kit, Center Section (Right Side)
	HG71973	Kit, Center Section (Left Side)
43	HG52162	Seal, Plug 1.250 x .250
44	HG52137	HFHCS, 3/8-16 X 1-1/2" Patch
45	HG51448	Plate, By-Pass
46	HG51804	O-Ring, -.111 x .103 x 424
47	HG42640	Shaft, Brake
48	HG52776	Pawl, Brake
49	HG44371	Washer, .63 x 1 x .05
50	HG44145	Ring, Retaining .625
51	HG52342	Gear, 13T Steel
52	HG51069	Washer, .72 x 1.16 x .04
53	HG52150	Shaft, Motor
54	HG71971	Assembly, Block 7 Piston
55	HG53502	Bearing, Thrust
56	HG51048	Trunnion, Swashplate
57	HG53246	HFHCS, 1/4-20 x 1-1/8"
58	HG9005110	Plug, 9/16-18
	-5600	
59	HG71990	Kit, Cover (Right Side)
	HG71992	Kit, Cover (Left Side)
60	HG44121	Bearing, Ball .75 x 40 x 12
61	HG53336	Spacer, .750 x 1.320 x .257
62	HG43327	Gear, 54T
63	HG52343	Gear, 46T
64	HG50132	Washer, .5 X 1 X .03
65	HG52586	Gear, 11T Steel
66	HG51083	Jackshaft Pin
67	HG72025	Kit, Housing Main (Right Side)
	HG72026	Kit, Housing Main (Left Side)
68	HG51100	Magnet, Ring
69	HG71976	Seal Kit
70	HG51626	Seal, Lip .375 x .75 x .25
71	HG51628	Ring, Retaining .375 External
72	HG52136	Rod, By-Pass
73	HG51677	Ring, Retaining .750 Internal
74	HG51629	Arm, By-Pass
75	HG51630	Ring, Retaining .375 External

REPLACEMENT DECALS AND INFORMATION PLATES

Ref. No.	Part No.	Description
1	483402	Decal, Belt Cover
2	483405	Decal, Warning
3	483425	Decal, ROPS
4	483505	Decal, Spinning Blades
5	481568	Decal, Traction Control
6	483633	Decal, Seat Replacement
7	483710	Decal, 36 Commercial
	483494	Decal, 48 Commercial
	483495	Decal, 52 Commercial
	484044	Decal, 61 Commercial
8	483406	Decal, Knives
9	483660	Decal, Adjustment SFZ
10	483695	Decal, Instrument Panel - SFZ36
	483499	Decal, Instrument Panel - SFZ48, SFZ52 & SFZ 61
11	483501	Decal, Front SFZ
12	483467	Decal, Cutting Height
13	483044	Decal, Patent

ELECTRICAL SCHEMATIC

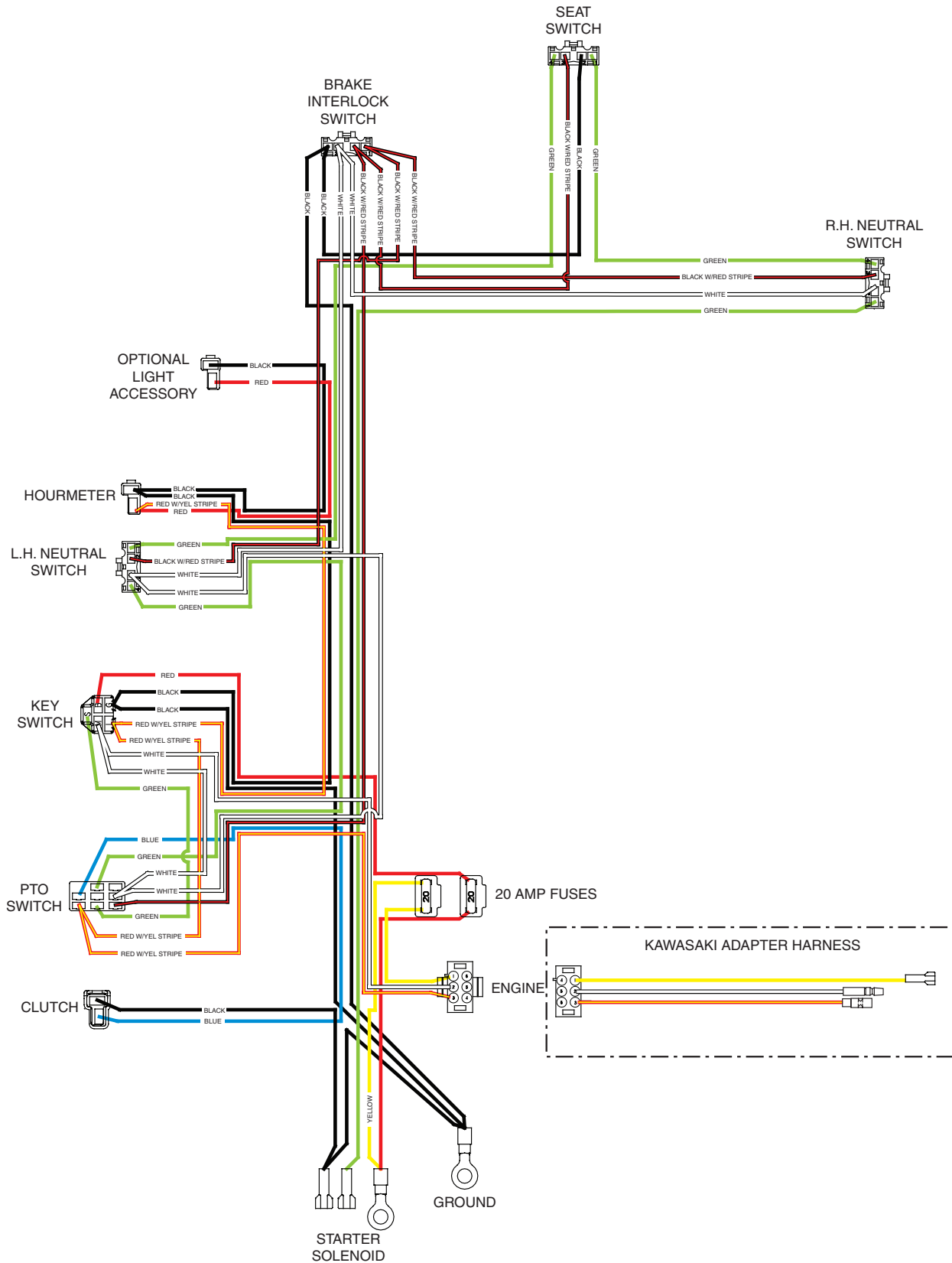

LIMITED WARRANTY - SFZ

Any part of the Scag commercial mower manufactured by Scag Power Equipment and found, in the reasonable judgment of Scag, to be defective in materials or workmanship, will be repaired or replaced by an Authorized Scag Service Dealer without charge for parts and labor during the periods specified below. This warranty is limited to the original purchaser and is not transferable. Proof of purchase will be required by the dealer to substantiate any warranty claims. All warranty work must be performed by an Authorized Scag Service Dealer.

This warranty is limited to the following specified periods from the date of the original retail purchase for defects in materials or workmanship:

- Wear items including drive belts, blades, hydraulic hoses and tires are warranted for ninety (90) days.
- Batteries are covered for ninety (90) days.
- Frame and structural components including the oil reservoir are warranted for one (1) year (parts and labor) for commercial use or three (3) years / 500 hours (whichever comes first) (Parts and labor) for non-commercial use.
- Cutter decks are warranted against cracking for a period of one (1) years. (parts and labor) for commercial use or three (3) years / 500 hours (whichever comes first) (First and second year of the warranty covers parts and labor. The third year covers parts or labor to repair) for non-commercial use. The repair or replacement of the cutter deck will be at the option of Scag Power Equipment. We reserve the right to request components for evaluation. This warranty does not cover any mower that has been subject to misuse, neglect, negligence, or accident, or that has been operated in any way contrary to the operating instructions as specified in the Operator's Manual.
- Engines and electric starters are covered by the engine manufacturer's warranty period.
- Major drive system components are warranted for one (1) year (parts and labor) for commercial use or three (3) year / 500 hour (whichever comes first) (Parts and labor) for non-commercial use by Scag Power Equipment. (commercial and non-commercial warranty excludes fittings, hoses, drive belts). The repair or replacement of the hydraulic axles will be at the option of Scag Power Equipment. This warranty does not cover any mower that has been subject to misuse, neglect, negligence, or accident, or that has been operated in any way contrary to the operating instructions as specified in the Operator's Manual.
- Electric clutches have a Limited Warranty for one (1) year (parts and labor) for commercial use or three (3) year / 500 hours (whichever comes first) (Parts and labor) for non-commercial use.
- Spindle assemblies have a Limited Warranty for one (1) year (parts and labor) for commercial use or three years / 500 hours (whichever comes first) (First and second year of the warranty covers parts and labor. The third year covers parts only) for non-commercial use.
- Any Scag product used for rental purposes is covered by a 90 day warranty.

The Scag mower, including any defective part must be returned to an Authorized Scag Service Dealer within the warranty period. The expense of delivering the mower to the dealer for warranty work and the expense of returning it to the owner after repair will be paid for by the owner. Scag's responsibility is limited to making the required repairs and no claim of breach of warranty shall be cause for cancellation or rescission of the contract of sale of any Scag mower. "Non-Commercial" use is defined as a single property owner, where the single property is the residence of the owner of the mower. If the mower is cutting more than the owners single property, it is deemed commercial use and the "non-commercial" warranty does not apply. Scag Power Equipment reserves the right to deny and / or void the non-commercial warranty if it believes it to be in commercial use.

This warranty does not cover any mower that has been subject to misuse, neglect, negligence, or accident, or that has been operated in any way contrary to the operating instructions as specified in the Operator's Manual. The warranty does not apply to any damage to the mower that is the result of improper maintenance, or to any mower or parts that have not been assembled or installed as specified in the Operator's Manual and Assembly Manual. The warranty does not cover any mower that has been altered or modified, changing performance or durability. In addition, the warranty does not extend to repairs made necessary by normal wear, or by the use of parts or accessories which, in the reasonable judgment of Scag, are either incompatible with the Scag mower or adversely affect its operation, performance or durability.

Scag Power Equipment reserves the right to change or improve the design of any mower without assuming any obligation to modify any mower previously manufactured. All other implied warranties are limited in duration to the one (1) year warranty commercial use, three (3) years for non-commercial use or ninety (90) days for mowers used for rental purpose. Accordingly, any such implied warranties including merchantability, fitness for a particular purpose, or otherwise, are disclaimed in their entirety after the expiration of the appropriate two year or ninety day warranty period. Scag's obligation under this warranty is strictly and exclusively limited to the repair or replacement of defective parts and Scag does not assume or authorize anyone to assume for them any other obligation. Some states do not allow limitations on how long an implied warranty lasts, so the above limitation may not apply to you.

Scag assumes no responsibility for incidental, consequential or other damages including, but not limited to, expense for gasoline, expense of delivering the mower to an Authorized Scag Service Dealer and expense of returning it to the owner, mechanic's travel time, telephone or telegram charges, rental of a like product during the time warranty repairs are being performed, travel, loss or damage to personal property, loss of revenue, loss of use of the mower, loss of time or inconvenience. Some states do not allow the exclusion or limitation of incidental or consequential damages, so the above limitation or exclusion may not apply to you. This warranty gives you specific legal rights, and you may also have other rights which vary from state to state.