

SCAG

POWER EQUIPMENT

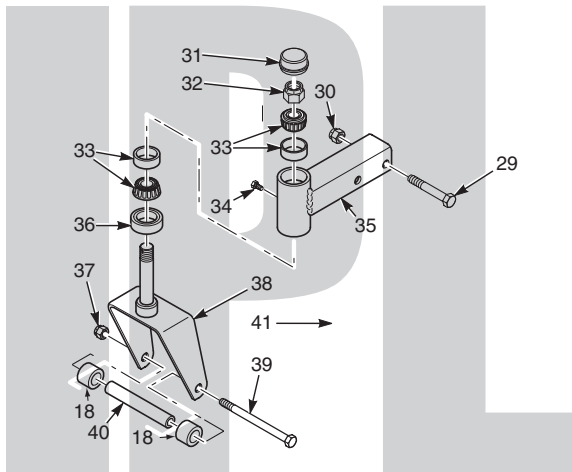

ILLUSTRATED PARTS MANUAL



Model SFZ Freedom Z

THIS MANUAL CONTAINS THE ILLUSTRATED PARTS LIST FOR MODELS:

SFZ36-18FS
SFZ48-20FS
SFZ48-26BS
SFZ52-20FS
SFZ52-26BS
SFZ61-28BS

with a serial number of F3100001 to F3199999
with a serial number of F3200400 to F3299999
with a serial number of F3300400 to F3399999
with a serial number of F3400250 to F3499999
with a serial number of F3500300 to F3599999
with a serial number of F3600001 to F3699999

Table of Contents

36 CUTTER DECK	2
48, 52 & 61 CUTTER DECKS	4
CUTTER DECK CONTROLS - SFZ36	6
CUTTER DECK CONTROLS - SFZ48 & SFZ52.....	8
CUTTER DECK CONTROLS - SFZ61	10
SHEET METAL COMPONENTS	12
SFZ ROLL-OVER PROTECTION SYSTEM	14
DRIVE SYSTEM COMPONENTS - SFZ36.....	16
DRIVE SYSTEM COMPONENTS - SFZ48, SFZ52 & SFZ61	18
EXHAUST AND ELECTRICAL SYSTEM - SFZ36.....	20
SFZ36 FUEL SYSTEM - EPA PHASE 2	22
SFZ36 FUEL SYSTEM - EPA PHASE 3	24
EXHAUST AND ELECTRICAL SYSTEM - SFZ48, SFZ52 & SFZ61.....	26
SFZ48, SFZ52 & SFZ61 FUEL SYSTEM - EPA PHASE 2	28
SFZ48, SFZ52 & SFZ61 FUEL SYSTEM - EPA PHASE 3	30
ZT-3100 HYDRAULIC AXLE ASSEMBLY	32
ZT-3400 HYDRAULIC AXLE ASSEMBLY -SFZ61	34
REPLACEMENT DECALS AND INFORMATION PLATES	36
ELECTRICAL SCHEMATIC	38

36 CUTTER DECK

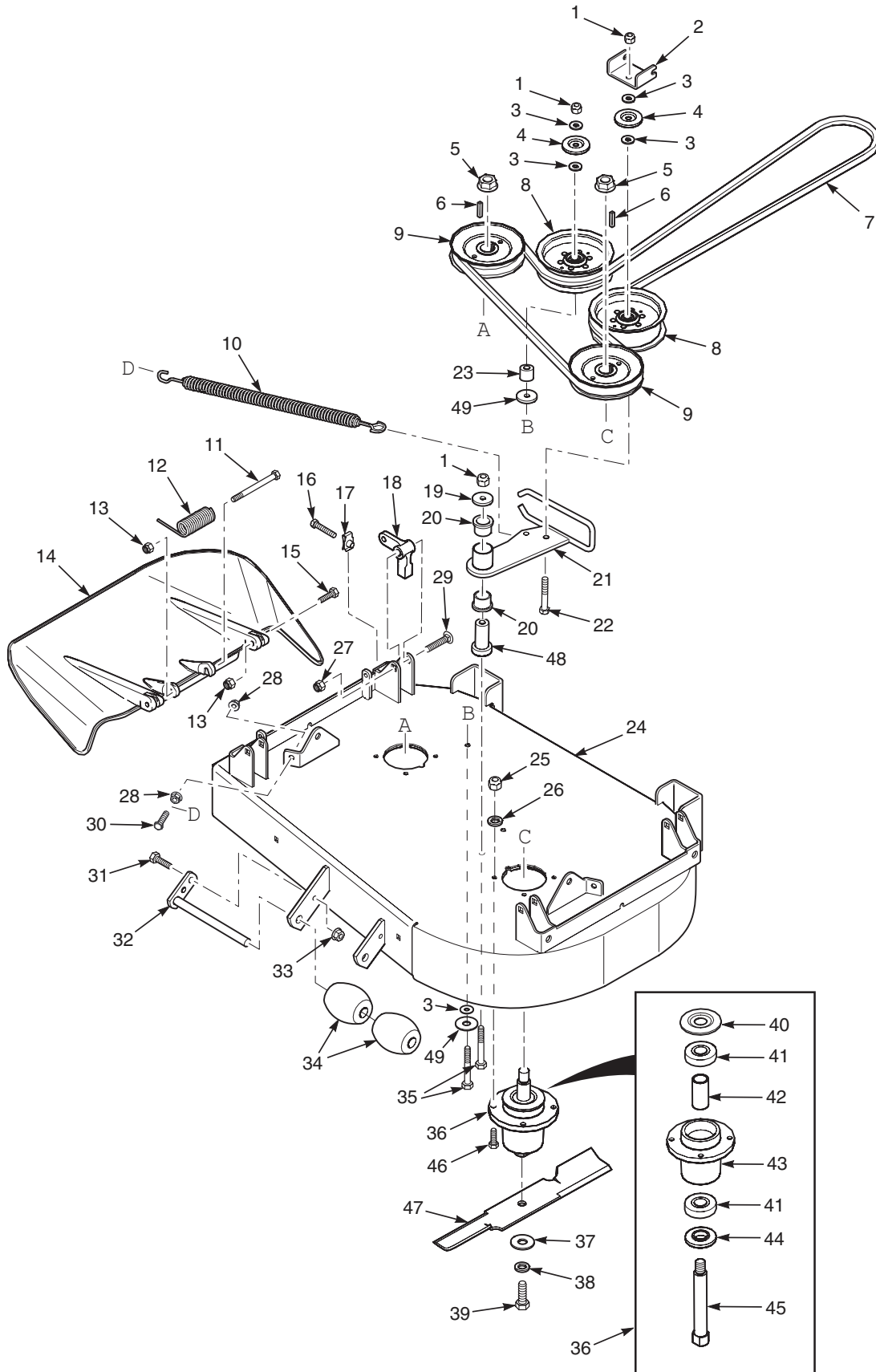

36 CUTTER DECK

Ref. No.	Part No.	Description
1	04021-09	Nut, Elastic Stop 3/8-16
2	424615	Bracket, Belt Guide
3	04043-04	Flatwasher, 3/8-.391 x .938 x .105
4	424367	Dust Shield
5	04112-06	Nut, 3/4-16 Spiral Lock
6	04063-01	Key, 1/4 x 1/4 x 1-1/4"
7	483667	Belt, Cutter Deck
8	483442	Pulley, 5" Idler
9	483324	Pulley, 5.73" OD - 25mm Bore
10	483375	Spring, Idler
11	04001-154	Bolt, Hex Head 5/16-18 x 4-3/4"
12	482245	Spring, Discharge Chute
13	04021-10	Nut, Elastic Stop 5/16-18
14	462031	Discharge Chute Assembly
15	04001-12	Bolt, Hex Head 5/16-18 x 1-3/4"
16	04107-05	Bolt, Hex Head 3/8-16 x 2" Special Lock
17	04110-03	U-Nut, 3/8-16
18	483361	Lever, Deck Level
19	04041-11	Flatwasher, 3/8-.406 x 1.50" x 7 Ga.
20	483453-03	Bearing
21	462133	Idler Arm (incl. item #20)
22	04001-31	Bolt, Hex Head 3/8-16 x 2-1/2"
23	43711	Spacer
24	462135	Cutter Deck w/Decals, SFZ36
25	04021-22	Nut, Elastic Stop 5/16-18

Ref. No.	Part No.	Description
26	04030-03	Lockwasher, 5/16 Spring
27	04021-11	Nut, Elastic Stop 7/16-14
28	04019-04	Nut, Serrated Flange 3/8-16
29	04003-42	Bolt, Carriage 7/16-14 x 2-1/4"
30	04001-136	Bolt, Hex Head 3/8-16 x 1-1/2" Gr.8
31	04001-09	Bolt, Hex Head 5/16-18 x 1"
32	451926	Shaft Weldment
33	04019-03	Nut, Serrated Flange 5/16-18
34	482295	Wheel, Anti-Scalp
35	04001-77	Bolt, Hex Head 3/8-16 x 3-1/2"
36	461950	Spindle Assembly
37	04043-06	Flatwasher, 5/8-11 x 1-1/2"
38	04030-07	Lockwasher, 1/2 Spring
39	04001-121	Bolt, Hex Head 5/8-11 x 1-1/2"
40	483304	Debris Shield
41	483303	Bearing
42	43693	Spacer, Bearing
43	462014	Spindle Housing Assembly (incl. item #41, 42)
44	43694	Protector, Bearing
45	43695	Shaft, Spindle
46	04001-175	Bolt, Hex Head 5/16-18 x 1-1/2" Gr.8
47	482878	Cutter Blade, 48"
48	43708	Pivot, Idler
49	04041-38	Flatwasher, 3/8-.406 x 2.25" x .1875

48, 52 & 61 CUTTER DECKS

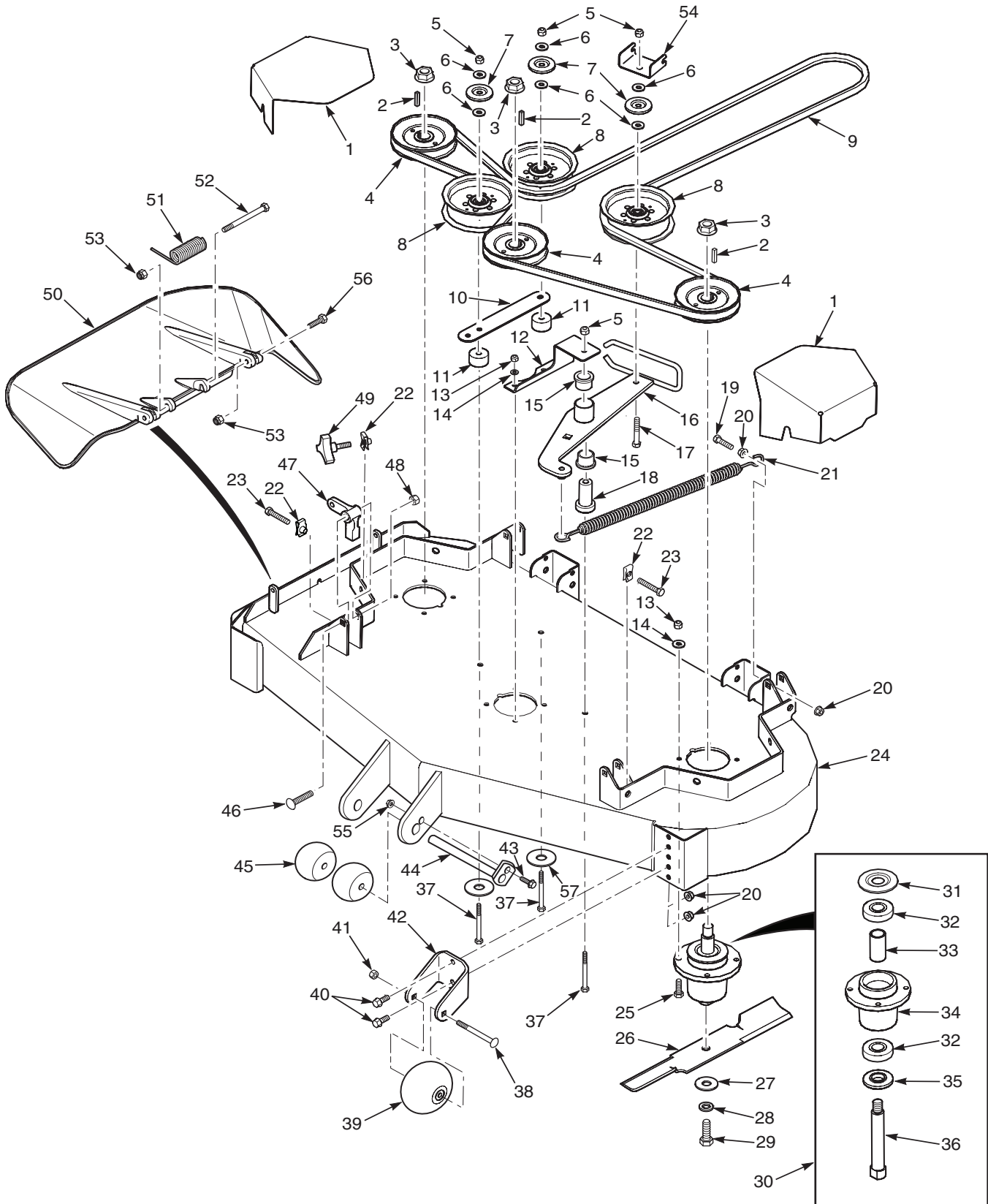

48, 52 & 61 CUTTER DECKS

	Part No.	Description	48	52	61
1	424528	Belt Cover	x	x	
	425260	Belt Cover			x
2	04063-01	Key, 1/4 x 1/4 x 1-1/4"	x	x	x
3	04112-06	Nut, 3/4-16 Spiral Lock	x	x	x
4	483323	Pulley, 5.13" OD - 25mm Bore	x		
	483324	Pulley, 5.73" OD - 25mm Bore		x	
	484026	Pulley, 6.32" OD - 25mm Bore			x
5	04021-09	Nut, Elastic Stop 3/8-16	x	x	x
6	04043-04	Flatwasher, 3/8-.391 x .938 x .105	x	x	x
7	424367	Dust Shield	x	x	x
8	483422	Pulley, 5" Idler	x	x	x
9	483325	Belt, Cutter Deck	x		
	483326	Belt, Cutter Deck		x	
	484031	Belt, Cutter Deck			x
10	424479	Brace, Pulley	x	x	x
11	43711	Spacer	x	x	x
12	424548	Support, Idler Pivot	x		
	424547	Support, Idler Pivot		x	
	425264	Support, Idler Pivot			x
13	04021-22	Nut, Elastic Stop	x	x	x
14	04030-03	Lockwasher, 5/16 Spring	x	x	x
15	483453-03	Bearing	x	x	x
16	462037	Idler Arm (incl. item #15)	x	x	x
17	04001-31	Bolt, Hex Head 3/8-16 x 2-1/2"	x	x	x
18	43708	Pivot, Idler	x	x	x
19	04001-136	Bolt, Hex Head 3/8-16 x 1-1/2 Gr.8	x	x	x
20	04019-04	Nut, Serrated Flange 3/8-16	x	x	x
21	483375	Spring, Idler	x	x	x
22	04110-03	U-Nut, 3/8-16	x	x	x
23	04107-04	Bolt, Hex Head 3/8-16 x 2"			
		Special Lock	x	x	x
24	462039	Cutter Deck w/Decals, SFZ48	x		
	462040	Cutter Deck w/Decals, SFZ52		x	
	462227	Cutter Deck w/Decals, SFZ61			x
25	04001-11	Bolt, Hex Head 5/16-18 x 1-1/2"	x	x	x
26	482877	Cutter Blade, 16-1/2"	x		
	482878	Cutter Blade, 18"		x	
	482879	Cutter Blade, 21"			x

	Part No.	Description	48	52	61
27	04043-06	Flatwasher, 5/8-.688 x 1.75 x .134 HD	x	x	x
28	04030-07	Lockwasher, 1/2 Spring	x	x	x
29	04001-121	Bolt, Hex Head 5/8-11 x 1-1/2"	x	x	x
30	461950	Spindle Assembly	x	x	x
31	483304	Debris Shield	x	x	x
32	483303	Bearing	x	x	x
33	43693	Spacer	x	x	x
34	462014	Spindle Housing Assembly (Incl. item #32, 33)	x	x	x
35	43694	Protector, Bearing	x	x	x
36	43695	Shaft, Spindle	x	x	x
37	04001-77	Bolt, Hex Head 3/8-16 x 3-1/2"	x	x	x
38	04003-26	Bolt, Carriage 3/8-16 x 4"	x	x	x
39	481632	Wheel, Anti-Scalp	x	x	x
40	04017-27	Bolt, Hex Head 3/8-16 x 1" Ser. Flg.	x	x	x
41	04021-05	Nut, Center Lock 3/8-16	x	x	x
42	422478	Bracket, Anti-Scalp	x	x	x
43	04001-09	Bolt, Hex Head 5/16-18 x 1"	x	x	x
44	451926	Shaft Weldment	x	x	x
45	482295	Wheel, Anti-Scalp	x	x	x
46	04003-42	Bolt, Carriage 7/16-14 x 2-1/4"	x	x	x
47	483361	Lever, Deck Level	x	x	x
48	04021-11	Nut, Elastic Stop 7/16-14	x	x	x
49	481625-01	Knob w/Stud	x	x	x
50	462031	Discharge Chute Assembly	x		
	462032	Discharge Chute Assembly		x	
	462213	Discharge Chute Assembly			x
51	482245	Spring, Discharge Chute	x	x	x
52	04001-154	Bolt, Hex Head 5/16-18 x 4-3/4"	x	x	x
53	04021-10	Nut, Elastic Stop 5/16-18	x	x	x
54	424615	Bracket, Belt Guide	x	x	x
55	04019-03	Nut, Serrated Flange 5/16-18	x	x	x
56	04001-12	Bolt, Hex Head 5/16-18 x 1-3/4"	x	x	x
57	04041-38	Flatwasher, 3/8-.406 x 2.25 x .1875	x	x	x

CUTTER DECK CONTROLS - SFZ36

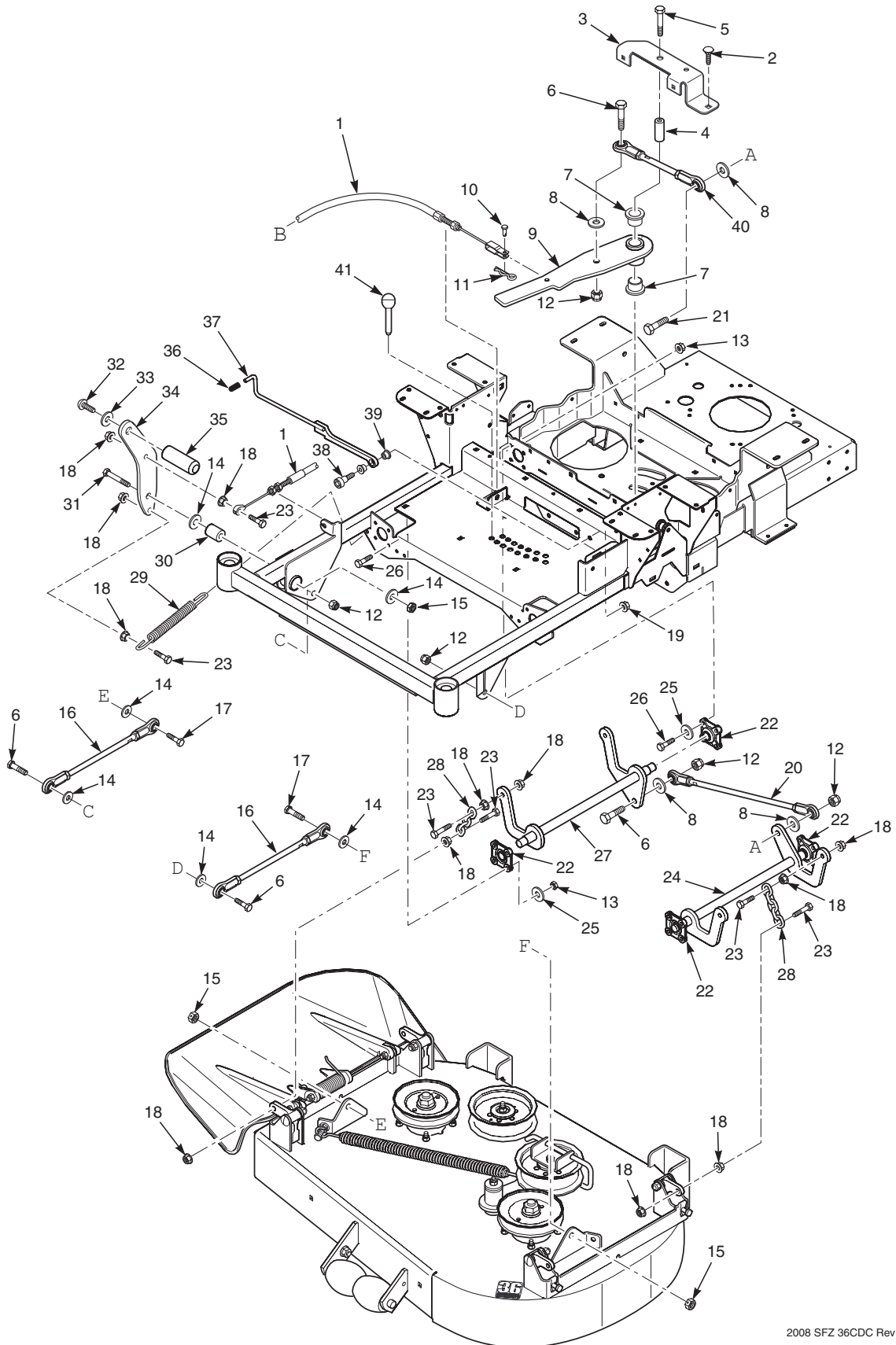

CUTTER DECK CONTROLS - SFZ36

Ref. No.	Part No.	Description
1	483341	Cable, Deck Lift
2	04003-31	Bolt, Carriage 3/8-16 x 3/4"
3	424827	Support, Idler Arm
4	43710	Spacer, Deck Lift Pivot
5	04001-90	Bolt, Hex Head 1/2-13 x 3-3/4"
6	04001-183	Bolt, Hex Head 1/2-13 x 1-3/4"
7	483453-03	Bearing
8	04040-07	Flatwasher, 1/2-.531 x 1.06 x .095
9	461999	Deck Lift Bellcrank Assembly
10	04064-17	Clevis Pin, 5/16 x 3/4"
11	04062-01	Hair Pin, .094 x 1.62"
12	04021-07	Nut, Elastic Stop 1/2-13
13	04021-10	Nut, Elastic Stop 5/16-18
14	04040-13	Flatwasher, 1/2-.562 x 1.375 x .109
15	04021-09	Nut, Center Lock 1/2-13
16	483332	Linkage, Push Arm
17	04001-71	Bolt, Hex Head 1/2-13 x 1-1/2"
18	04019-04	Nut, Serrated Flange 3/8-16
19	04021-09	Nut, Elastic Stop 3/8-16
20	483349	Linkage Assembly, Deck Lift
21	04001-52	Bolt, Hex Head 1/2-13 x 2-1/2"
22	483334	Bearing, Deck Lift
23	04001-20	Bolt, Hex Head 3/8-16 x 1-1/2"
24	451982	Weldment, Deck Lift LH
25	04040-14	Flatwasher, 1/4-.312 x .750 x .065
26	04001-09	Bolt, Hex Head 5/16-18 x 1"
27	451983	Weldment, Deck Lift RH
28	482628	Chain, Deck lift
29	483374	Spring, Deck Lift
30	43710	Sleeve, Deck Lift Pivot
31	04001-74	Bolt, Hex Head 1/2-13 x 3"
32	04105-01	Bolt, Head Socket 5/8-11 x 1-1/2"
33	04030-07	Lockwasher, 5/8 Spring
34	424844	Pedal, Foot Bracket
35	424504	Foot Pedal
36	483492	Grip, Deck Latch
37	491254	Weldment, Deck Latch
38	04009-06	Bolt, Shoulder 1/2 x 1/2
39	483453-10	Bearing
40	483328	Linkage Assembly, Deck Lift
41	483498	Pin, Height Adjuster

CUTTER DECK CONTROLS - SFZ48 & SFZ52

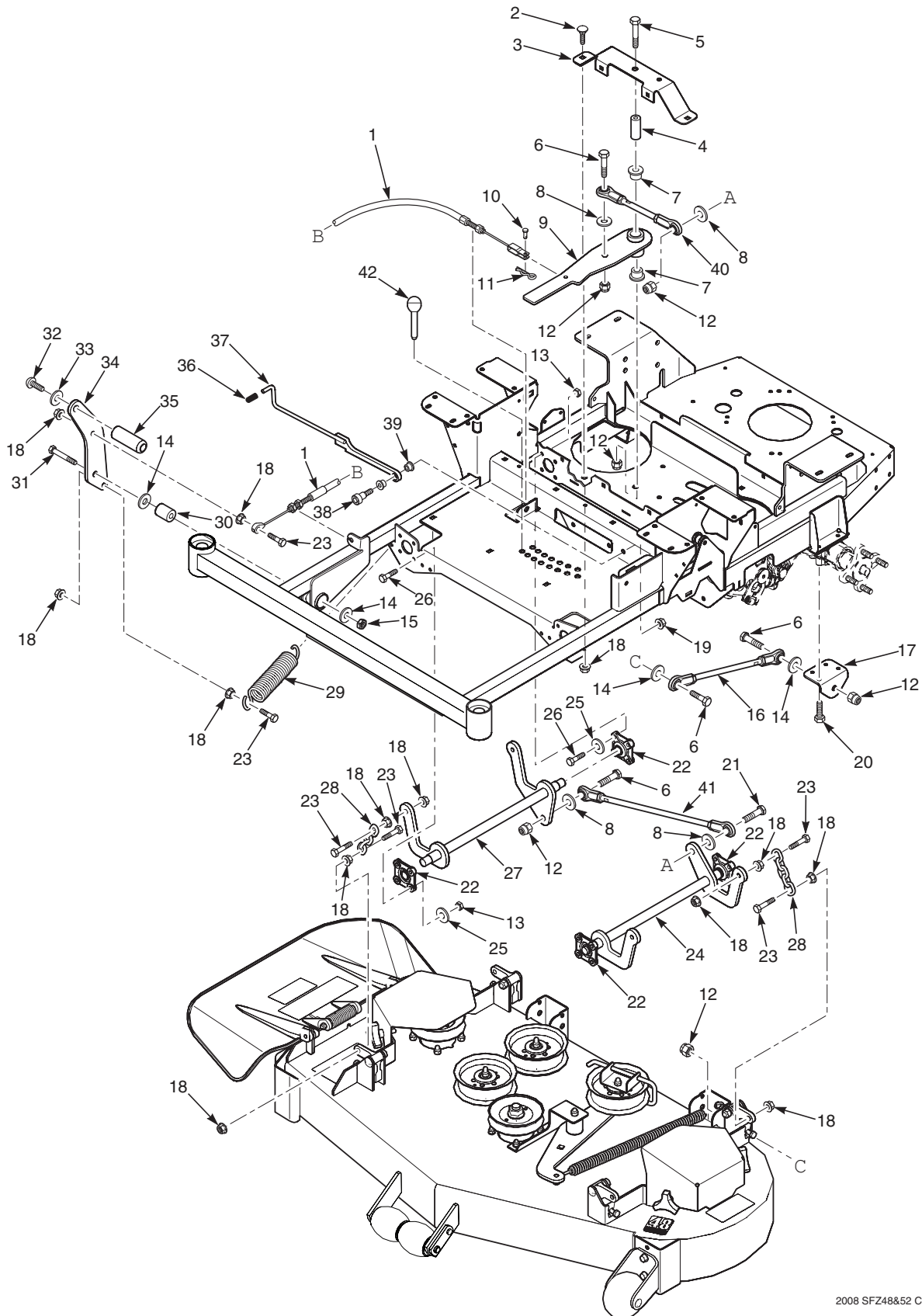

CUTTER DECK CONTROLS - SFZ48 & SFZ52

Ref. No.	Part No.	Description
1	483341	Cable, Deck Lift
2	04003-31	Bolt, Carriage 3/8-16 x 3/4"
3	424476	Support, Idler Arm
4	43710	Spacer, Deck Lift Pivot
5	04001-90	Bolt, Hex Head 1/2-13 x 3-3/4"
6	04001-183	Bolt, Hex Head 1/2-13 x 1-3/4"
7	483453-03	Bearing
8	04040-07	Flatwasher, 1/2-.531 x 1.06 x .095
9	461999	Deck Lift Bellcrank Assembly
10	04064-17	Clevis Pin, 5/16 x 3/4"
11	04062-01	Hair Pin, .094 x 1.62"
12	04021-07	Nut, Elastic Stop 1/2-13
13	04021-10	Nut, Elastic Stop 5/16-18
14	04040-13	Flatwasher, 1/2-.562 x 1.375 x .109
15	04021-09	Nut, Center Lock 1/2-13
16	483332	Linkage, Push Arm
17	424489	Bracket, Push Arm Link
18	04019-04	Nut, Serrated Flange 3/8-16
19	04021-09	Nut, Elastic Stop 3/8-16
20	04001-49	Bolt, Hex Head 5/16-18 x 3"
21	04001-52	Bolt, Hex Head 1/2-13 x 2-1/2"
22	483334	Bearing, Deck Lift
23	04001-20	Bolt, Hex Head 3/8-16 x 1-1/2"
24	451868	Weldment, Deck Lift LH
25	04040-14	Flatwasher, 1/4-.312 x .750 x .065
26	04001-09	Bolt, Hex Head 5/16-18 x 1"
27	451867	Weldment, Deck Lift RH
28	482628	Chain, Deck lift
29	483374	Spring, Deck Lift
30	43710	Sleeve, Deck Lift Pivot
31	04001-74	Bolt, Hex Head 1/2-13 x 3"
32	04105-01	Bolt, Head Socket 5/8-11 x 1-1/2"
33	04030-07	Lockwasher, 5/8 Spring
34	424535	Pedal, Foot Bracket
35	424504	Foot Pedal
36	483492	Grip, Deck Latch
37	491254	Weldment, Deck Latch
38	04009-06	Bolt, Shoulder 1/2 x 1/2
39	483453-10	Bearing
40	483328	Linkage Assembly, Deck Lift
41	483367	Linkage Assembly, Deck Lift
42	483498	Pin, Height Adjuster

CUTTER DECK CONTROLS - SFZ61

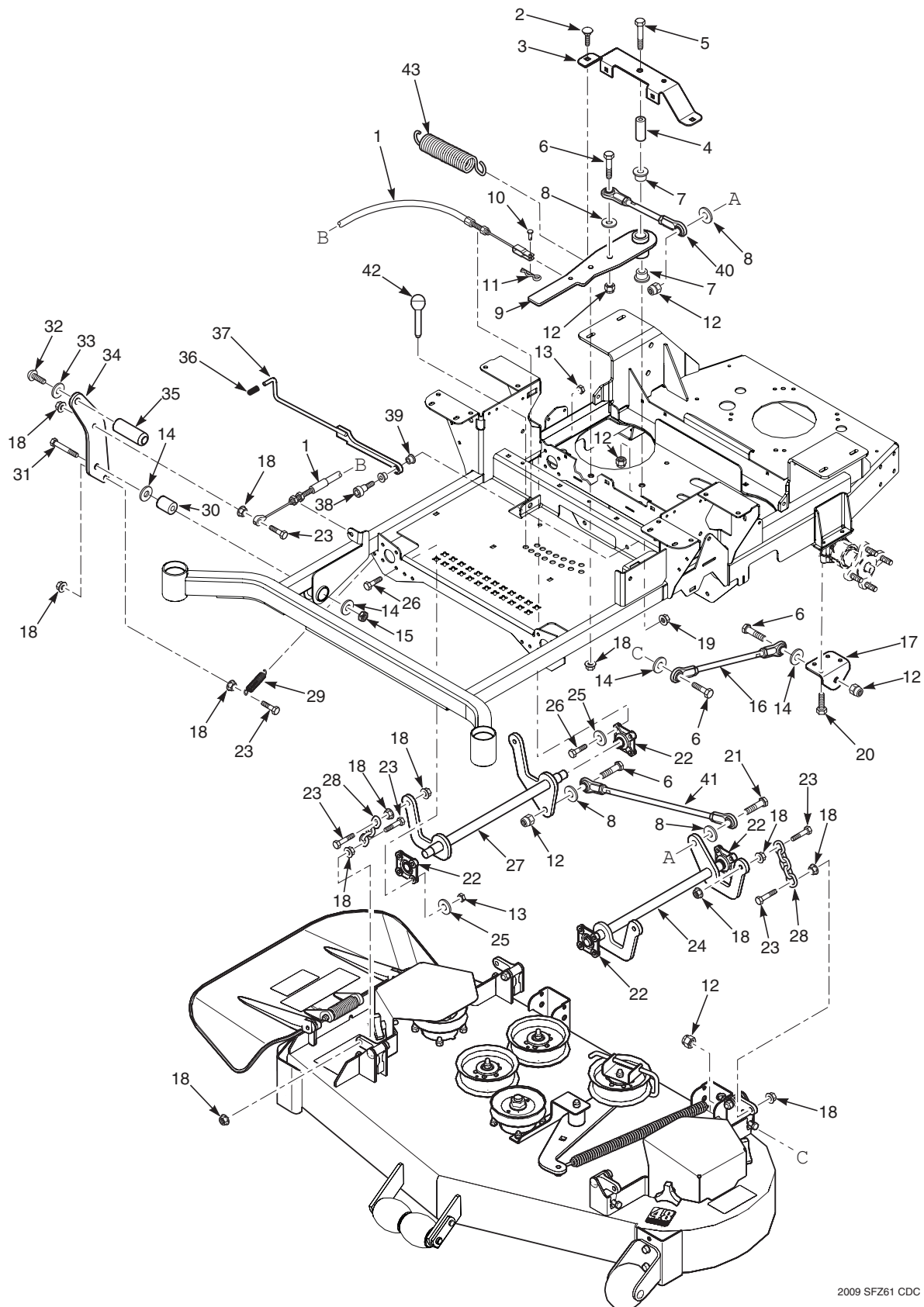

CUTTER DECK CONTROLS - SFZ61

Ref. No.	Part No.	Description
1	483341	Cable, Deck Lift
2	04003-31	Bolt, Carriage 3/8-16 x 3/4"
3	424476	Support, Idler Arm
4	43710	Spacer, Deck Lift Pivot
5	04001-90	Bolt, Hex Head 1/2-13 x 3-3/4"
6	04001-183	Bolt, Hex Head 1/2-13 x 1-3/4"
7	483453-03	Bearing
8	04040-07	Flatwasher, 1/2-.531 x 1.06 x .095
9	461999	Deck Lift Bellcrank Assembly
10	04064-17	Clevis Pin, 5/16 x 3/4"
11	04062-01	Hair Pin, .094 x 1.62"
12	04021-07	Nut, Elastic Stop 1/2-13
13	04021-10	Nut, Elastic Stop 5/16-18
14	04040-13	Flatwasher, 1/2-.562 x 1.375 x .109
15	04021-09	Nut, Center Lock 1/2-13
16	483332	Linkage, Push Arm
17	424489	Bracket, Push Arm Link
18	04019-04	Nut, Serrated Flange 3/8-16
19	04021-09	Nut, Elastic Stop 3/8-16
20	04001-49	Bolt, Hex Head 5/16-18 x 3"
21	04001-52	Bolt, Hex Head 1/2-13 x 2-1/2"
22	483334	Bearing, Deck Lift
23	04001-20	Bolt, Hex Head 3/8-16 x 1-1/2"
24	452112	Weldment, Deck Lift LH
25	04040-14	Flatwasher, 1/4-.312 x .750 x .065
26	04001-09	Bolt, Hex Head 5/16-18 x 1"
27	452113	Weldment, Deck Lift RH
28	482628	Chain, Deck lift
29	484038	Spring, Deck Lift
30	43710	Sleeve, Deck Lift Pivot
31	04001-74	Bolt, Hex Head 1/2-13 x 3"
32	04105-01	Bolt, Head Socket 5/8-11 x 1-1/2"
33	04030-07	Lockwasher, 5/8 Spring
34	424535	Pedal, Foot Bracket
35	424504	Foot Pedal
36	483492	Grip, Deck Latch
37	491254	Weldment, Deck Latch
38	04009-06	Bolt, Shoulder 1/2 x 1/2
39	483453-10	Bearing
40	483328	Linkage Assembly, Deck Lift
41	483367	Linkage Assembly, Deck Lift
42	483498	Pin, Height Adjuster
43	483374	Spring, Deck Lift

SHEET METAL COMPONENTS

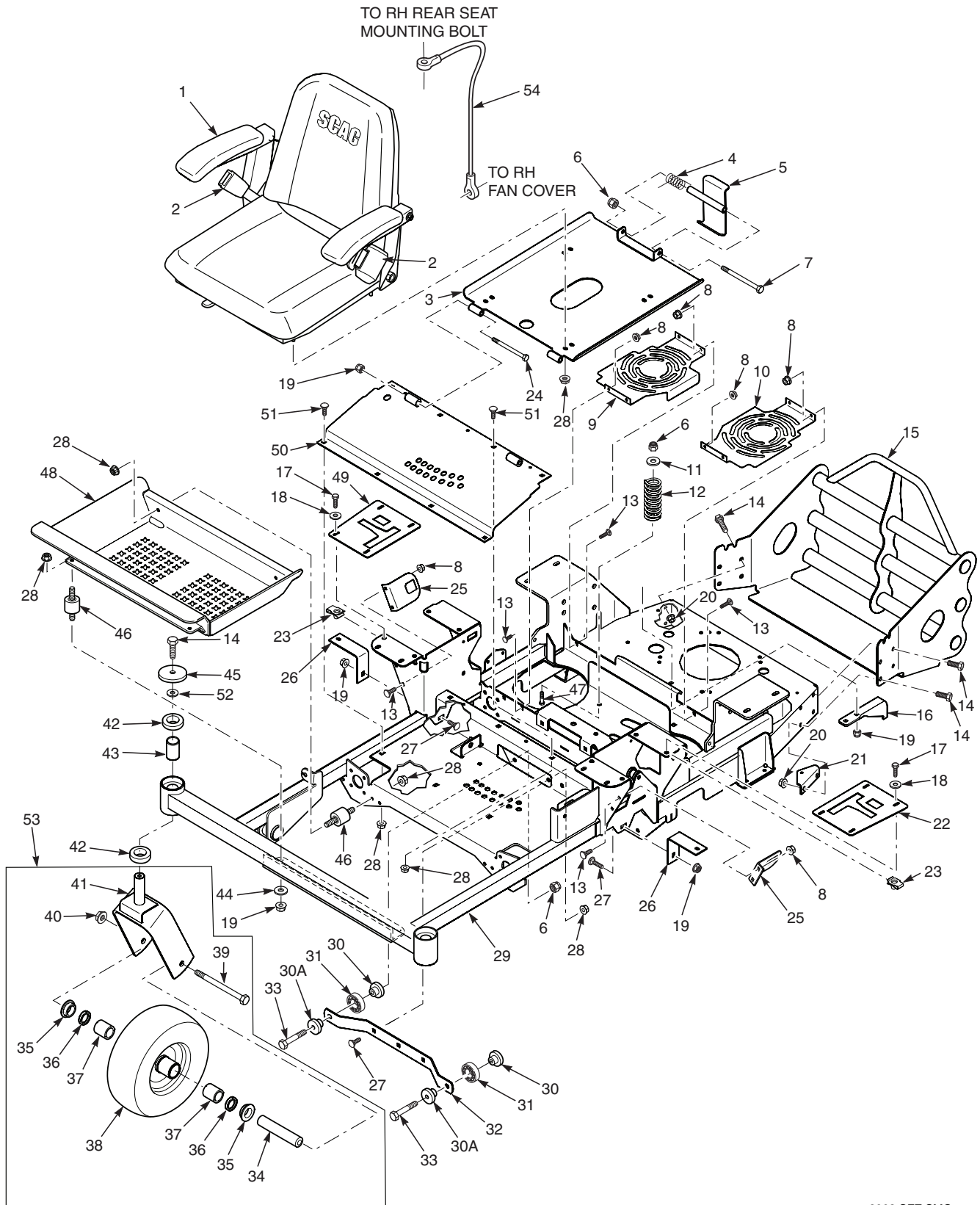

SHEET METAL COMPONENTS

	Part No.	Description	36	48 52	61	Ref. No.	Part No.	Description	36	48 52	61
1	483408	Seat Assembly	x	x	x	27	04003-12	Bolt, Carriage 5/16-18 x 3/4"	x	x	x
	483544	Back Cushion	x	x	x	28	04019-03	Nut, Serrated Flange 5/16-18	x	x	x
	483545	Bottom Cushion	x	x	x	29	462309	Main Frame w/Decals	x		
	483549	Arm Rest Kit	x	x	x		462310	Main Frame w/Decals		x	
	483543	Seat Adjustment Kit	x	x	x		462311	Main Frame w/Decals			x
2	483412	Seat Belt Assembly, Retractable	x	x	x	30	43719	Spacer, Bearing	x		
	461990	Hardware Package, Mounting	x	x	x		43703	Spacer, Bearing		x	x
3	462034	Seat Base w/Decal	x	x	x	30A	43719	Spacer, Bearing (SFZ36 Only)			
4	483371	Spring, Seat Latch	x	x	x		04041-07	Flatwasher, 3/8-.391 x .938 x .105	x		
5	451883	Seat Latch	x	x	x	31	483379	Bearing	x		x
6	04021-09	Nut, Elastic Stop 3/8-16	x	x	x	32	424480	Support, Deck Guide	x	x	x
7	04001-100	Bolt, Hex Head 3/8-16 x 6"	x	x	x	33	04001-21	Bolt, Hex Head 3/8-16 x 1-3/4"		x	
8	04019-02	Nut, Serrated Flange 1/4-20	x	x	x		04001-31	Bolt, Hex Head 3/8-16 x 2-1/2"	x		x
9	424829	Cover, Fan RH	x			34	43698	Sleeve, Front Caster Wheel		x	x
	424585	Cover, Fan RH		x	x	35	483453-09	Bearing	x	x	x
10	424828	Cover, Fan LH	x			36	483486	Seal, 1 x 1.375 x .25	x	x	x
	424550	Cover, Fan LH		x	x	37	483453-08	Bearing	x	x	x
11	04041-07	Flatwasher, 3/8-.391 x .938 x .105	x	x	x	38	483409	Caster Wheel Assembly	x	x	x
12	483372	Spring, Seat	x	x	x		483417	Tire, 11 x 4-5.00 2-Ply	x	x	x
13	04003-07	Bolt, Carriage 1/4-20 x 1"	x	x	x		483410	Rim, 5 x 3.25 w/Valve	x	x	x
14	04001-19	Bolt, Hex Head 3/8-16 x 1"	x	x	x	39	04001-80	Bolt, Hex Head 1/2-13 x 6-1/2"	x	x	x
15	451995	Rear Bumper	x			40	04021-07	Nut, Elastic Stop 1/2-13	x	x	x
	451929	Rear Bumper		x	x	41	451845	Yoke, Caster Wheel	x	x	x
	483535	Plug, Bumper Tube (not shown)	x	x	x	42	483466	Bearing	x	x	x
16	424792	Bracket, Anti-Rotation	x				424636	Spacer, Yoke (not shown)	x	x	x
	424523	Bracket, Anti-Rotation		x		43	43736	Spacer, Caster Bearing	x	x	x
	425328	Bracket, Anti-Rotation			x	44	04040-15	Flatwasher, 5/16-.375 x .875 x .083	x	x	x
17	04001-14	Bolt, Hex Head 1/4-20 x 1"	x	x	x	45	04041-38	Flatwasher, 3/8-.406 x 2.25 x .188	x	x	x
18	04040-14	Flatwasher, 1/4-.312 x .750 x .065	x	x	x	46	483493	Rubber Isolator	x	x	x
19	04021-10	Nut, Elastic Stop 5/16-18	x	x	x	47	04003-11	Bolt, Carriage 3/8-16 x 1-1/4"	x	x	
20	04019-04	Nut, Serrated Flange 3/8-16	x	x	x	48	451889	Footplate Weldment	x	x	
21	424639	Bracket, Dump Valve	x	x	x		452104	Footplate Weldment (61 Only)			x
22	462129	Control Plate LH	x			49	462130	Control Plate RH	x		x
	462023	Control Plate LH		x	x		462024	Control Plate RH		x	x
23	04110-01	U-Nut 1/4-20	x	x	x	50	462005	Weldment, Deck Lift Cover	x	x	x
24	04001-73	Bolt, Hex Head 5/16-18 x 3-3/4"	x	x	x	51	04003-14	Bolt, Carriage 5/16-18 x 1/2"	x	x	x
25	424511	Bracket, Switch Mount	x	x	x	52	04040-11	Flatwasher, 7/16-.50 x 1.250 x .083	x	x	x
26	424516	Bracket, Tank Mount	x	x	x	53	462015	Caster Wheel Assembly w/Yoke	x	x	x
						54	483559	Cable, Seat Stop	x	x	x

SFZ ROLL-OVER PROTECTION SYSTEM

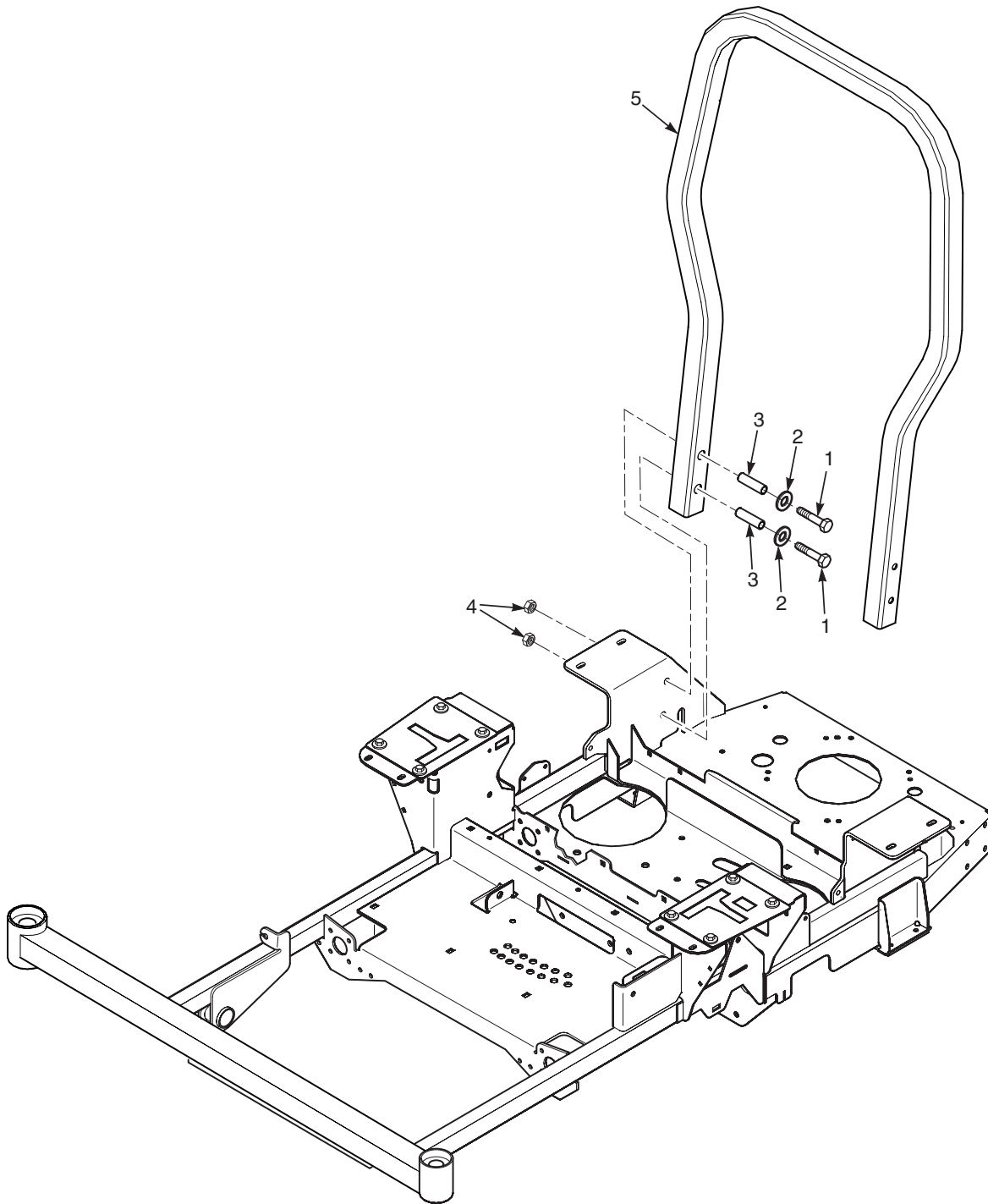

SFZ ROLL-OVER PROTECTION SYSTEM

Ref. No.	Part No.	Description
1	04001-184	Bolt, Hex Head 1/213 x 3-1/4" Gr. 8
2	04040-13	Flatwasher, 1/2 - .562 x 1.375 x .109
3	43743	Bushing, SFZ ROPS
4	04117-04	Nut, Flanged Elastic Stop, 1/2-13
5	462106	ROPS, SFZ36
	462021	ROPS, SFZ48, SFZ52 & SFZ61

DRIVE SYSTEM COMPONENTS - SFZ36

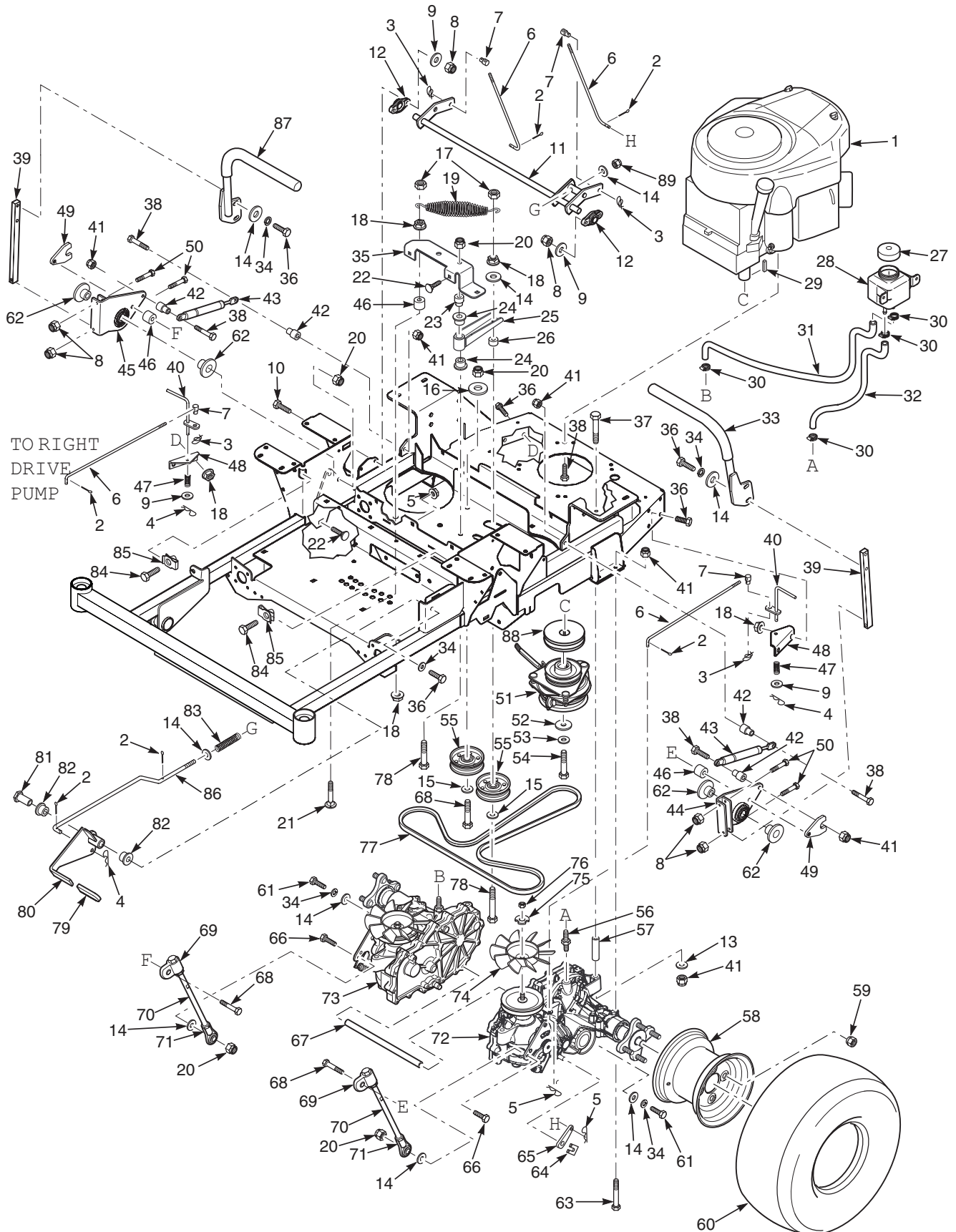

DRIVE SYSTEM COMPONENTS - SFZ36

Ref. No.	Part No.	Description
1	483707	Engine, Briggs & Stratton 20hp
	484221	Engine, Kawasaki 18hp
2	04061-01	Cotter Pin, 3/32 x 1"
3	04069-01	Pin, Rue Cotter 3/8" Dia.
4	04062-02	Hair Pin, .080 x 1.19"
5	04019-03	Nut, Serrated Flange 5/16-18
6	44162	Rod, Brake Adjustment
7	43726	Joint, Swivel
8	04021-08	Nut, Elastic Stop 1/4-20
9	04040-14	Flatwasher, 1/4-.312 x .750 x .065
10	04017-07	Bolt, Serrated Flange 1/4-20 x 1-1/4"
11	451998	Weldment, Brake Lever
12	483504	Bearing
13	04040-15	Flatwasher, 5/16-.375 x .875 x .083
14	04041-07	Flatwasher, 3/8-.391 x .938 x .105
15	04043-04	Flatwasher, 3/8-.391 x .938 x .105 HD
16	04041-11	Flatwasher, 3/8-.406 x 1.5 x 7 GA.
17	04021-05	Nut, Center Lock 3/8-16
18	04019-04	Nut, Serrated Flange 3/8-16
19	483087	Spring, Transmission Idler
20	04021-09	Nut, Elastic Stop 3/8-16
21	04003-03	Bolt, Carriage 3/8-16 x 2"
22	04003-12	Bolt, Carriage 5/16-18 x 3/4"
23	43715	Shaft Pivot, Idler Arm
24	483453-04	Bearing
25	462122	Transmission Idler Arm Assembly
26	43720	Spacer, Idler Pulley
27	483514	Cap
28	483438	Reservoir Assembly
29	04063-31	Key, 1/4 x 1/4 x 1-3/4"
30	48136-05	Clamp, 0.87" Max Dia.
31	483431	Hose, RH Transmission
32	483698	Hose, LH Transmission
33	462001	Handle Bar Assembly, w/Grip
	482340	Grip
34	04030-04	Lockwasher, 3/8" Spring
35	424827	Support, Idler Arm
36	04001-19	Bolt, Hex Head 3/8-16 x 1"
37	04001-191	Bolt, Hex Head 5/16-18 x 6"
38	04001-11	Bolt, Hex Head 5/16-18 x 1-1/2"
39	424498	Bar, Control Lever
40	451912	Dump Valve Lever
41	04021-10	Nut, Elastic Stop 5/16-18
42	43602	Spacer, Pump Dampener
43	482794	Dampener
44	462127	Control Link, LH
45	462128	Control Link, RH

Ref. No.	Part No.	Description
46	43674	Spacer
47	482070	Spring
48	424639	Bracket, Dump Mounting
49	424687	Nut, Control Linkage
50	04001-04	Bolt, Hex Head 1/4-20 x 1-1/2"
51	462012	Electric Clutch Assembly
52	04041-28	Flatwasher, 7/16-.469 x 1.75 x .25
53	04030-05	Lockwasher, 7/16" spring
54	04102-03	Bolt, Hex Head 7/16-20 x 2-1/4" Patch
55	483638	Pulley, 3-1/2" Dia.
56	482800-04	Fitting, Transmission
57	43765	Spacer, Axle
58	483658	Rim w/Valve Stem
59	04028-02	Wheel Nut, 1/2-20
60	483657	Wheel Assembly
	483659	Tire, 18 x 7-8 4-Ply
61	04001-46	Bolt, Hex Head 3/8-16 x 2-1/4"
62	43719	Spacer, Linkage
63	04001-39	Bolt, Hex Head 5/16-18 x 2-1/4"
64	HG51190	Clip, Brake Lever (order through Hydro-Gear)
65	HG52639	Lever, Brake (order through Hydro-Gear)
66	04001-32	Bolt, Hex Head 3/8-16 x 1-1/4"
67	43766	Spacer, Axle
68	04001-45	Bolt, Hex Head 3/8-16 x 2"
69	483563	Rod End, Adjustable
	04020-25	Nut, Jam 3/8-24 UNF RH
70	483668	Linkage, Pump
71	483682	Stake, Rod End Assembly
72	483663	Transaxle Assy., (ZJ-KMEF-3LKG-1FXX)
73	483664	Transaxle Assy., (ZJ-GMEF-3LKF-1FXX)
74	HG52476	Fan (order through Hydro-Gear)
75	HG51523	Fan Washer (order through Hydro-Gear)
76	HG51244	Fan Nut (order through Hydro-Gear)
77	483666	Belt, TRansmission Drive
78	04001-54	Bolt, Hex Head 3/8-16 x 3"
79	482102	Grip, Brake Handle
80	462010	Brake Handle Assembly
81	43722	Spacer, Brake Handle
82	483453-05	Bearing
83	483538	Spring, Brake
84	04107-01	Bolt, Hex Head 3/8-16 x 1-1/4" Special Lock
85	04110-03	U-Nut, 3/8-16
86	44164	Rod, Brake Linkage
87	462000	Handle Bar w/Grip
	482340	Grip
88	483670	Pulley, 4-1/2" Dia. 1" Bore
89	04021-18	Nut, Elastic Stop 3/8-24 Gr. 8

DRIVE SYSTEM COMPONENTS - SFZ48, SFZ52 & SFZ61

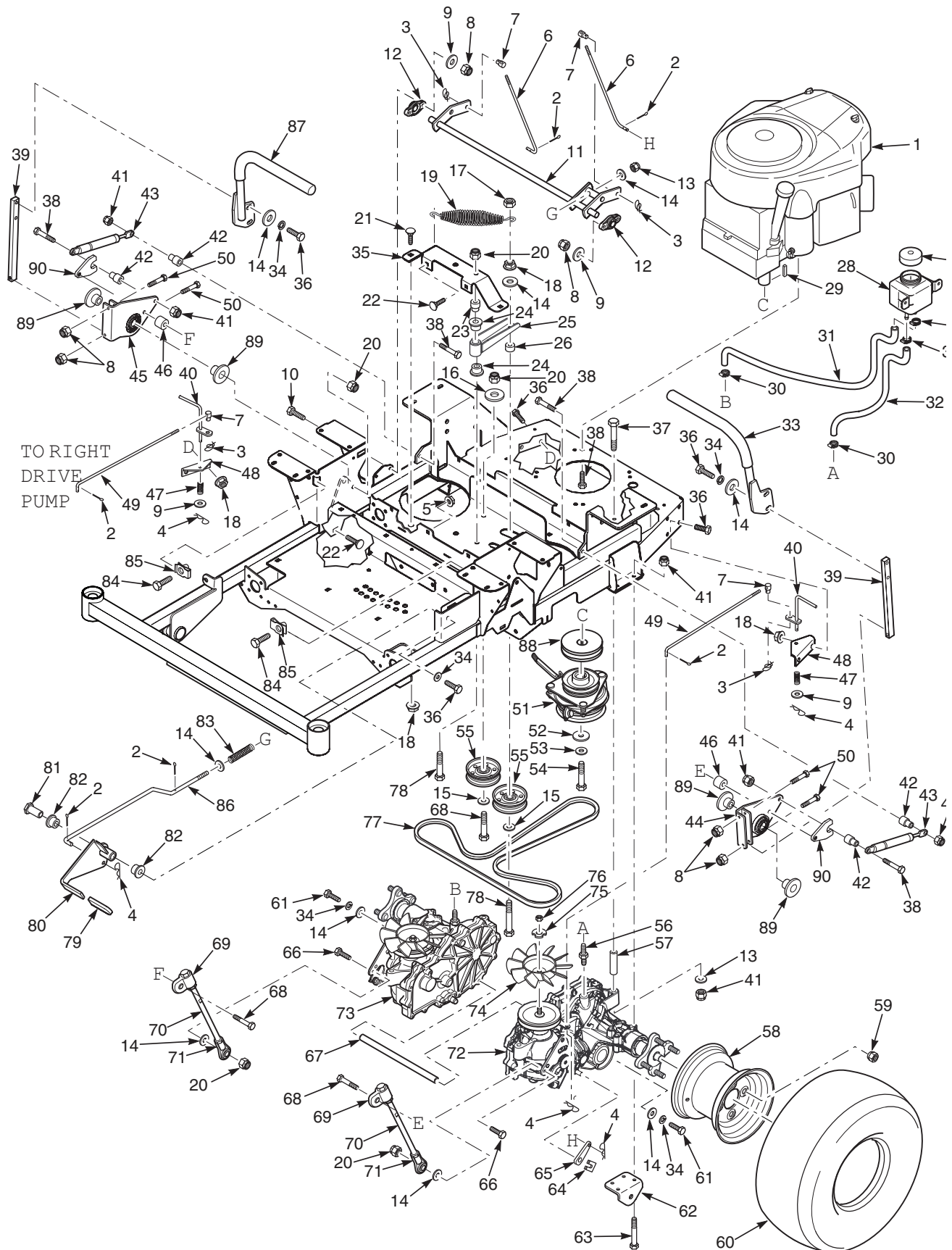

DRIVE SYSTEM COMPONENTS - SFZ48, SFZ52 & SFZ61

Ref. No.	Part No.	Description
1	483465	Engine, Briggs & Stratton 26hp
	484222	Engine, Kawasaki 20hp
	484133	Engine, Briggs & Stratton 28hp (61 Only)
2	04061-01	Cotter Pin, 3/32 x 1"
3	04069-01	Pin, Rue Cotter 3/8" Dia.
4	04062-02	Hair Pin, .080 x 1.19"
5	04019-03	Nut, Serrated Flange 5/16-18
6	44165	Rod, Brake Adjustment
7	43726	Joint, Swivel
8	04021-08	Nut, Elastic Stop 1/4-20
9	04040-14	Flatwasher, 1/4-.312 x .750 x .065
10	04017-07	Bolt, Serrated Flange 1/4-20 x 1-1/4"
11	451884	Weldment, Brake Lever
12	483504	Bearing
13	04040-15	Flatwasher, 5/16-.375 x .875 x .083
14	04041-07	Flatwasher, 3/8-.391 x .938 x .105
15	04043-04	Flatwasher, 3/8-.391 x .938 x .105 HD
16	04041-11	Flatwasher, 3/8-.406 x 1.5 x 7 GA.
17	04021-05	Nut, Center Lock 3/8-16
18	04019-04	Nut, Serrated Flange 3/8-16
19	483087	Spring, Transmission Idler
20	04021-09	Nut, Elastic Stop 3/8-16
21	04003-31	Bolt, Carriage 3/8-16 x 3/4"
22	04003-12	Bolt, Carriage 5/16-18 x 3/4"
23	43715	Shaft Pivot, Idler Arm
24	483453-04	Bearing
25	462122	Transmission Idler Arm Assembly
26	43720	Spacer, Idler Pulley
27	483514	Cap
28	483438	Reservoir Assembly
29	04063-31	Key, 1/4 x 1/4 x 1-3/4"
	04063-02	Key, 1/4 x 1/4 x 2-1/4" - SFZ-61 Only
30	48136-05	Clamp, 0.87" Max Dia.
31	483431	Hose, RH Transmission
32	483432	Hose, LH Transmission
33	462001	Handle Bar Assembly, w/Grip
	482340	Grip
34	04030-04	Lockwasher, 3/8" Spring
35	424476	Support, Idler Arm
36	04001-19	Bolt, Hex Head 3/8-16 x 1"
37	04001-95	Bolt, Hex Head 5/16-18 x 5"
38	04001-11	Bolt, Hex Head 5/16-18 x 1-1/2"
39	424498	Bar, Control Lever
40	451912	Dump Valve Lever
41	04021-10	Nut, Elastic Stop 5/16-18
42	43602	Spacer, Pump Dampener
43	482794	Dampener
44	462127	Control Link, LH
45	462128	Control Link, RH
46	43674	Spacer
47	482070	Spring
48	424639	Bracket, Dump Mounting

Ref. No.	Part No.	Description
49	44162	Linkage, Dump Valve
50	04001-04	Bolt, Hex Head 1/4-20 x 1-1/2"
51	462012	Electric Clutch Assembly (48, 52)
	462228	Electric Clutch Assembly (61)
52	04041-28	Flatwasher, 7/16-.469 x 1.75 x .25 (48, 52)
	43832	Spacer, Crankshaft, SFZ-61 (repl. 04041-28)
53	04030-05	Lockwasher, 7/16" spring
54	04102-03	Bolt, Hex Head 7/16-20 x 2-1/4" Patch
	04102-08	Bolt, Hex Head 7/16-20 x 1-1/2" Patch SFZ-61
55	483638	Pulley, 3-1/2" Dia.
56	482800-04	Fitting, Transmission
57	43700	Spacer, Axle
58	481868	Rim w/Valve Stem (48, 52, 61)
59	04028-02	Wheel Nut, 1/2-20
60	483390	Wheel Assembly (48, 52)
	483389	Tire, 20 x 10-8 2-Ply (48, 52, 61)
	484056	Wheel Assembly (61)
61	04001-46	Bolt, Hex Head 3/8-16 x 2-1/4"
62	424489	Bracket, Pusharm Link
63	04001-49	Bolt, Hex Head 5/16-18 x 3"
64	HG51190	Clip, Brake Lever (order through Hydro-Gear)
65	HG52639	Lever, Brake (order through Hydro-Gear)
66	04001-32	Bolt, Hex Head 3/8-16 x 1-1/4"
67	43701	Spacer, Axle
68	04001-45	Bolt, Hex Head 3/8-16 x 2"
69	483563	Rod End, Adjustable
	04020-25	Nut, Jam 3/8-24 UNF RH
70	483574	Linkage, Pump
71	483575	Stake, Rod End Assembly
72	483527	Transaxle Assy., (ZL-KCEF-3LKG-1EXX)
	484064	Transaxle Assy., (ZU-KCEE-3LKG-12XX) - SFZ61
73	483528	Transaxle Assy., (ZL-GCEF-3LKF-1EXX)
	484065	Transaxle Assy., (ZU-GCEE-3LKF-12XX) - SFZ61
74	HG51862	Fan (order through Hydro-Gear)
75	HG51523	Fan Washer (order through Hydro-Gear)
76	HG44133	Fan Nut (order through Hydro-Gear)
77	483314	Belt, TRansmission Drive
78	04001-54	Bolt, Hex Head 3/8-16 x 3"
79	482102	Grip, Brake Handle
80	462010	Brake Handle Assembly
81	43722	Spacer, Brake Handle
82	483453-05	Bearing
83	483538	Spring, Brake
84	04107-01	Bolt, Hex Head 3/8-16 x 1-1/4" Special Lock
85	04110-03	U-Nut, 3/8-16
86	44157	Rod, Brake Linkage
87	462000	Handle Bar w/Grip
	482340	Grip
88	483320	Pulley, 4-1/2" Dia. 1" Bore
	484071	Pulley, 4-1/2" Dia. 1.125" Bore
89	43719	Spacer, Linkage
90	424687	Nut, Control Linkage

EXHAUST AND ELECTRICAL SYSTEM - SFZ36

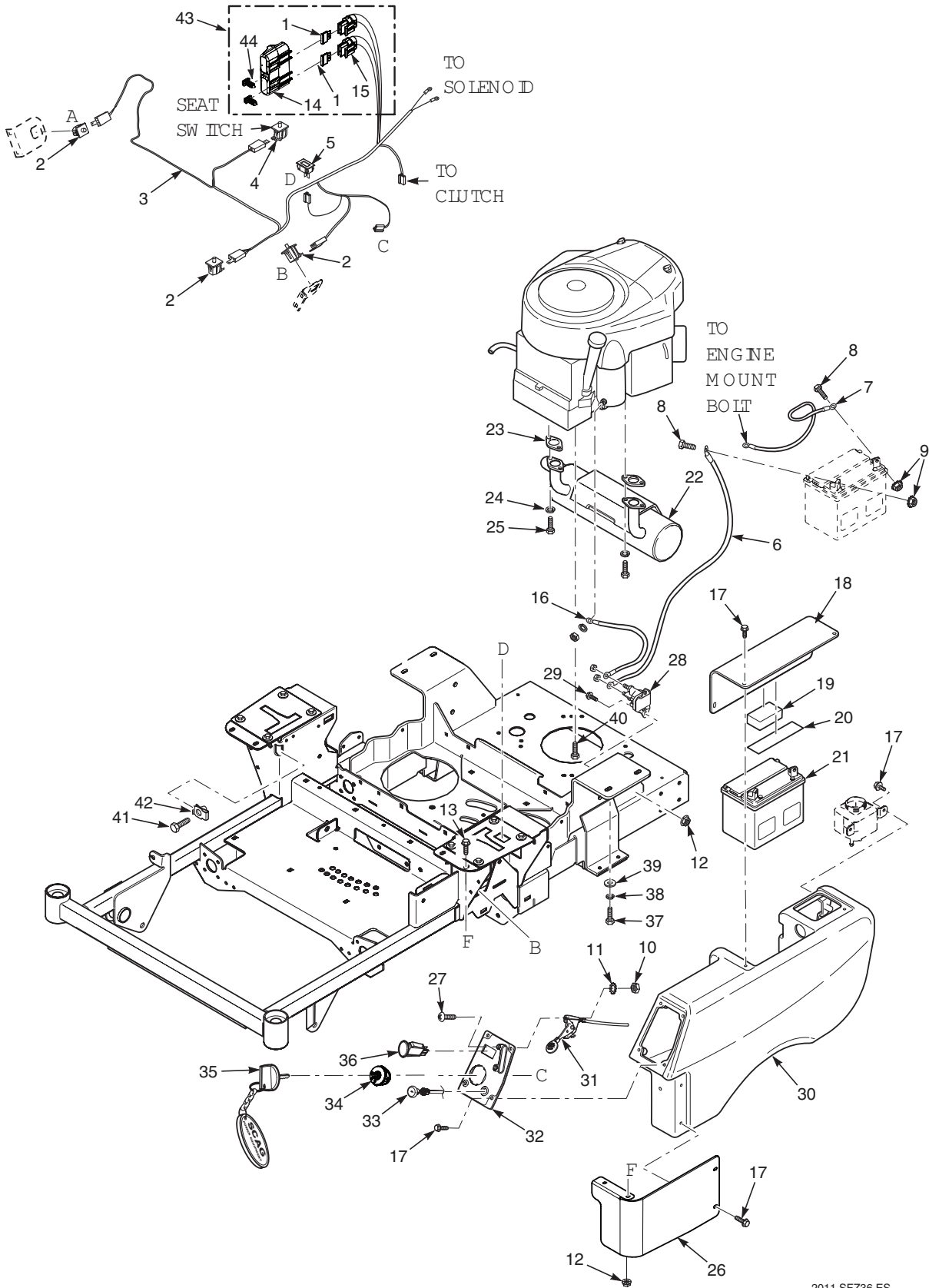

EXHAUST AND ELECTRICAL SYSTEM - SFZ36

Ref. No.	Part No.	Description
1	48298	Fuse, 20 amp
2	483473	Switch
3	483621	Wire Harness, Main
	483629	Wire Harness Adapter, Kawasaki (not shown)
4	483474	Switch, Seat
5	483537	Hourmeter
6	48029-13	Battery Cable, Red 25"
7	48029-11	Battery Cable, Black 27"
8	04001-44	Bolt, Hex Head 1/4-20 x 1/2"
9	04020-02	Nut, 1/4-20
10	04020-01	Nut, Hex #10-32
11	04031-01	Lockwasher, #10 External Tooth
12	04019-02	Nut, Serrated Flange 1/4-20
13	04017-05	Bolt, Hex Head 1/4-20 x 3/4" Serr. Flange
14	483571	Cover, Sealed Double
15	483629	Fuse Holder
16	48029-09	Battery Cable, Red 9"
17	04017-04	Bolt, Hex Head 1/4-20 x 1/2" Serr. Flange
18	461996	Battery Cover (incl. items 19 & 20)
19	483452	Pad, Battery Hold Down
20	483508	Rubber Pad
21	483665	Battery (not avail. through Scag)
22	483381	Muffler, Briggs & Stratton
	484036	Muffler, Kawasaki
23	**	Exhaust Gasket
24	**	Lockwasher
25	**	Bolt
26	424830	Control Cover, LH
27	04010-12	Screw, #10-32 X 3/4"
28	483278	Solenoid
29	04001-03	Bolt, Hex Head 1/4-20 x 0.63"

Ref. No.	Part No.	Description
30	483672	Tank, LH
31	483434	Throttle Cable
32	462136	Instrument Panel w/Decal
33	483435	Choke Cable
34	483472	Ignition Switch
35	483366	Key, Ignition
	483609	Key w/Shroud
	462069	Key Assembly w/Fob
36	483957	PTO Switch
37	04001-08	Bolt, Hex Head 5/16-18 x 3/4"
38	04030-03	Lockwasher, 5/16" Spring
39	04040-15	Flatwasher, 5/16-.375 x .875 x .083
40	04001-32	Bolt, Hex Head 3/8-16 x 1-1/4" (Kawasaki)
	04030-04	Lockwasher, 3/8" Spring (Kawasaki)
41	04107-03	Bolt, Hex Head 3/8-16 x 1-1/4" Special Lock
42	04110-03	U-Nut, 3/8-16
43	483642	Double Fuse Assy. (incl. items 1, 14, 15, 46)
44	482588	Clip, Wire

** Available through individual engine manufacturer.

SFZ36 FUEL SYSTEM - EPA PHASE 2 (models produced prior to 1/1/2011)

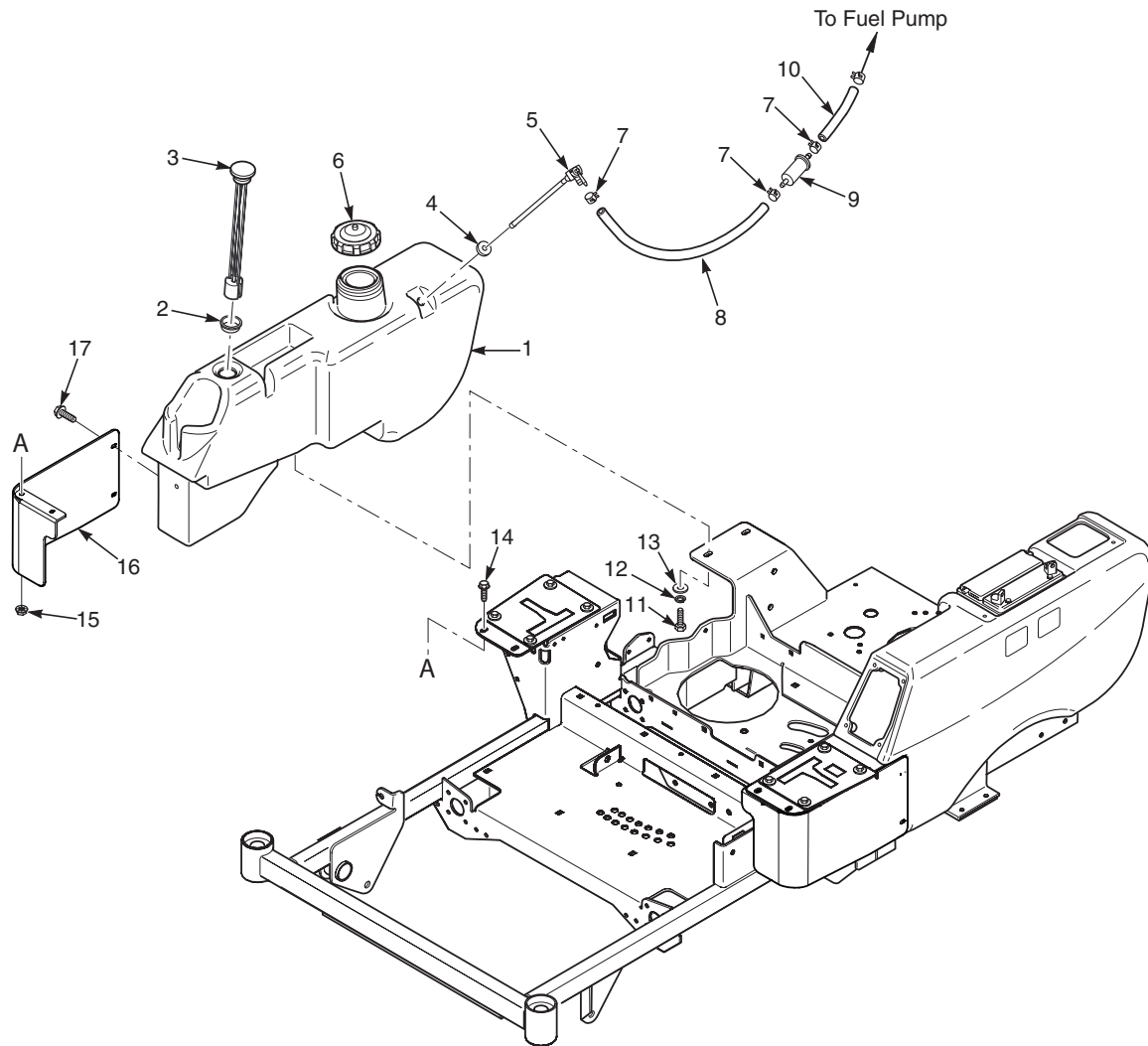

**SFZ36 FUEL SYSTEM - EPA PHASE 2
(models produced prior to 1/1/2011)**

Ref. No.	Part No.	Description
1	462099	Fuel Tanks Assembly
2	483536	Grommet
3	483523	Fuel Gauge Assembly
4	482571	Bushing, 0.56 Dia. Viton
5	483557	Fuel Tube Assembly
6	483792	Fuel Cap
7	48059-01	Clamp, Fuel Hose 1/4" ID
8	483617	Fuel Hose, 1/4" ID Non-Perm (order by inch)
9	*	Fuel Filter
10	*	Fuel Hose
11	04001-08	Bolt, Hex Head 5/16-18 x 3/4"
12	04030-03	Lockwasher, 5/16- Spring
13	04040-15	Flatwasher, 5/16-.375 x .875 x .083
14	04017-05	Bolt, Hex Head 1/4-20 x 3/4" Serrated Flange
15	04019-02	Nut, Serrated Flange 1/4-20
16	424822	Control Cover, RH
17	04017-04	Bolt, Hex Head 1/4-20 x 1/2" Serrated Flange

* = Available through engine manufacturer only.

SFZ36 FUEL SYSTEM - EPA PHASE 3 (models produced after to 1/1/2011)

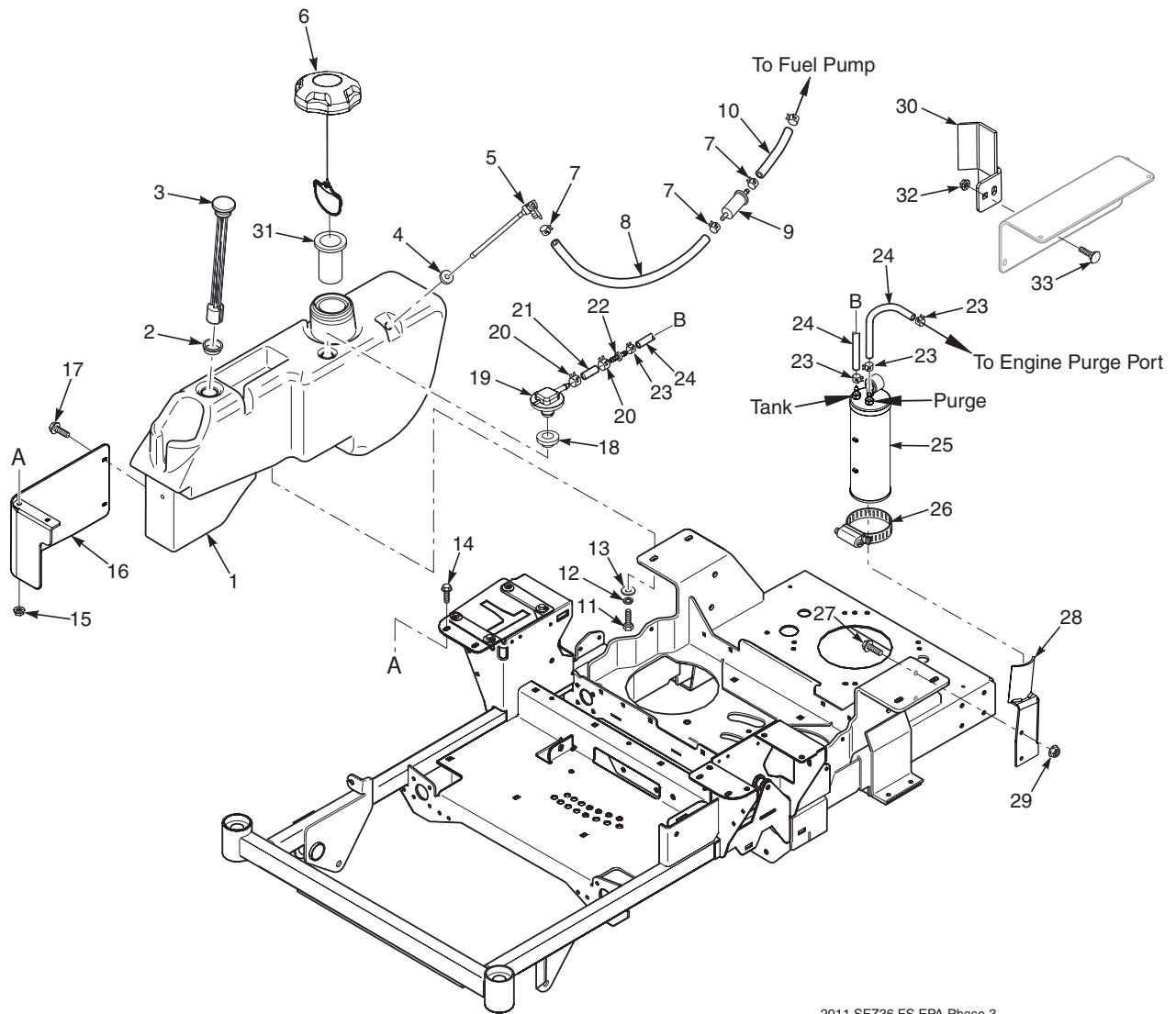

2011 SFZ36 FS EPA Phase 3

**SFZ36 FUEL SYSTEM - EPA PHASE 3
(models produced after to 1/1/2011)**

Ref. No.	Part No.	Description
1	462291	Fuel Tanks Assembly
2	483536	Grommet
3	484243	Fuel Gauge Assembly
4	482571	Bushing, 0.56 Dia. Viton
5	483557	Fuel Tube Assembly
6	484286	Fuel Cap, Tethered
7	48059-01	Clamp, Fuel Hose 1/4" ID
8	483617	Fuel Hose, 1/4" ID Non-Perm (order by inch)
9	*	Fuel Filter
10	*	Fuel Hose
11	04001-08	Bolt, Hex Head 5/16-18 x 3/4"
12	04030-03	Lockwasher, 5/16- Spring
13	04040-15	Flatwasher, 5/16-.375 x .875 x .083
14	04017-05	Bolt, Hex Head 1/4-20 x 3/4" Serrated Flange
15	04019-02	Nut, Serrated Flange 1/4-20
16	424822	Control Cover, RH
17	04017-04	Bolt, Hex Head 1/4-20 x 1/2" Serrated Flange
18	484285	Grommet, Viton
19	484333	Remote Vent
20	48059-02	Clamp, Fuel Hose 7/32 ID
21	484347	Hose, 1/4" Vapor Recovery (order by inch)
22	484343-01	Mender, 1/4 x 3/16 w/0.02 Hole
23	48059-05	Clamp, Vapor Recovery Hose 3/16"
24	484345	Hose, 3/16" (order by inch)
25	484342	Carbon Canister
26	48136-17	Clamp, Hose
27	04001-01	Bolt, Hex Head 1/4-20 x 3/4"
28	452230	Bracket Weldment
29	04019-02	Nut, Serrated Flange 1/4-20
30	452231	Guard Weldment, Canister
31	484279-01	Tube, Fuel Tank Insert
32	04019-03	Nut, 5/16-18 Serrated Flange
33	04003-14	Bolt, Carriage 5/16-18 x 1/2"

* = Available through engine manufacturer only.

EXHAUST AND ELECTRICAL SYSTEM - SFZ48, SFZ52 & SFZ61

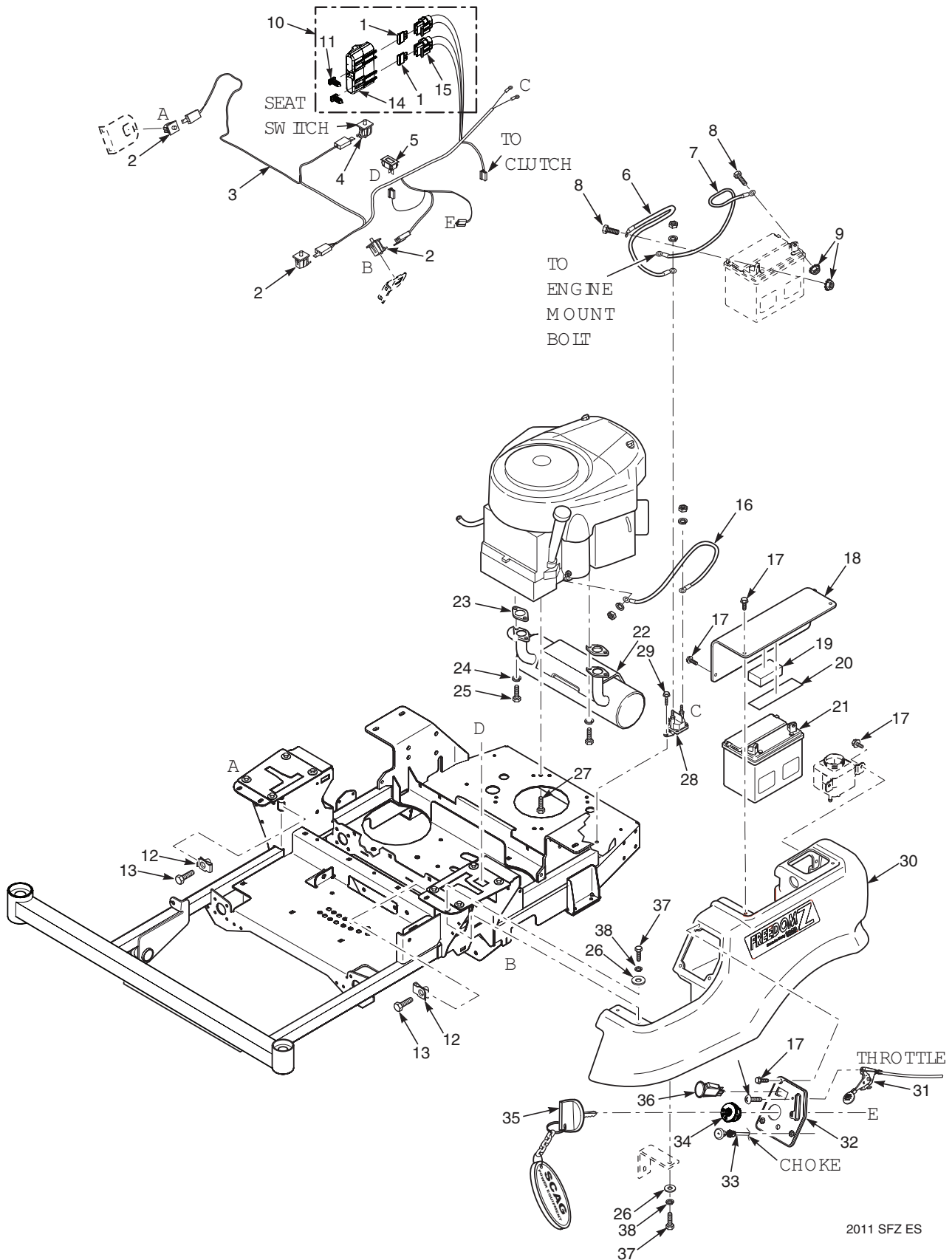

2011 SFZ ES

EXHAUST AND ELECTRICAL SYSTEM - SFZ48, SFZ52 & SFZ61

Ref. No.	Part No.	Description
1	48298	Fuse, 20 amp
2	483473	Switch
3	483621	Wire Harness, Main
	483628	Wire Harness Adapter, Kawasaki (not shown)
4	483474	Switch, Seat
5	483537	Hourmeter
6	48029-13	Battery Cable, Red 25"
7	48029-11	Battery Cable, Black 27"
8	04001-44	Bolt, Hex Head 1/4-20 x 1/2"
9	04020-02	Nut, 1/4-20
10	483642	Double Fuse Assy. (incl. items 1, 14, 15, 46)
11	482588	Clip, Wire
12	04110-03	U-Nut, 3/8-16
13	04107-03	Bolt, Hex Head 3/8-16 x 1-1/4" Special Lock
14	483571	Cover, Sealed Double
15	483629	Fuse Holder
16	48029-09	Battery Cable, Red 9"
17	04017-04	Bolt, Hex Head 1/4-20 x 1/2" Serr. Flange
18	461996	Battery Cover (incl. items 19 & 20)
19	483452	Pad, Battery Hold Down
20	483508	Rubber Pad
21	483665	Battery (not avail. through Scag)
22	483381	Muffler, Briggs & Stratton
	484036	Muffler, Kawasaki
23	**	Exhaust Gasket
24	**	Lockwasher
25	**	Bolt
26	04040-15	Flatwasher, 5/16-.375 x .875 x .083
27	04001-32	Bolt, Hex Head 3/8-16 x 1-1/4" (Kawasaki)
	04030-04	Lockwasher, 3/8" Spring (Kawasaki)
	04001-11	Bolt, Hex Head 5/16-18 x 1-1/2" (Briggs)
	04019-03	Nut, 5/16-18 Serrated Flange
	04031-03	Lockwasher, 5/16" Spring (Briggs)
	04011-07	Capscrew, Hex Head 3/8-16 x 1-1/4" Self Tap (Briggs)

Ref. No.	Part No.	Description
28	483278	Solenoid
29	04011-14	Bolt, Self Tapping 1/2-20 x 3/4" Shakeproof
30	483364	Tank, LH
31	483434	Throttle Cable
32	462036	Instrument Panel w/Decal
33	483435	Choke Cable
34	483472	Ignition Switch
35	483366	Key, Ignition
	483609	Key w/Shroud
	462069	Key Assembly w/Fob
36	483957	PTO Switch
37	04001-08	Bolt, Hex Head 5/16-18 x 3/4"
38	04030-03	Lockwasher, 5/16" Spring

** Available through individual engine manufacturer.

SFZ48, SFZ52 & SFZ61 FUEL SYSTEM - EPA PHASE 2 (models produced prior to 1/1/2011)

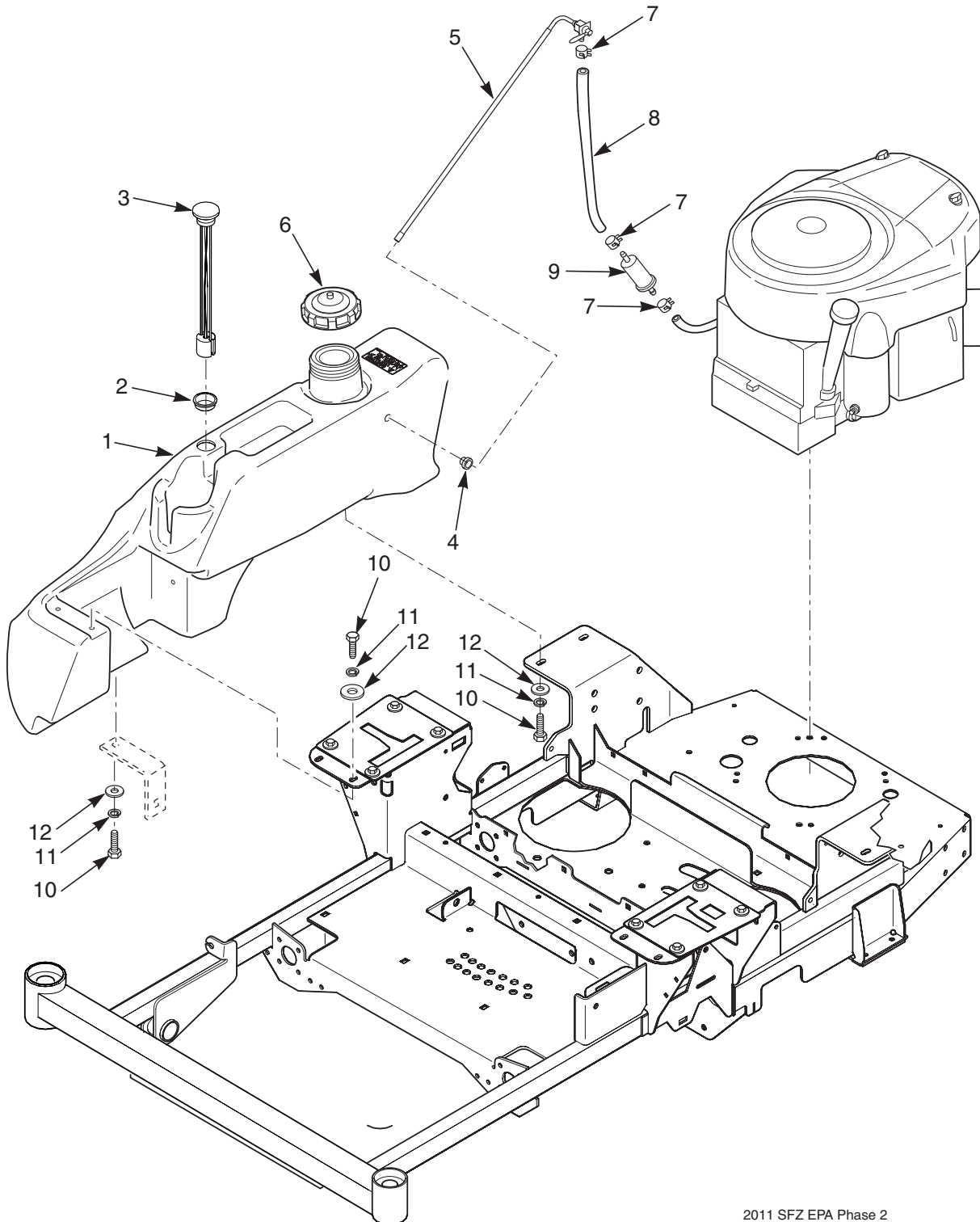

2011 SFZ EPA Phase 2

**SFZ48, SFZ52 & SFZ61 FUEL SYSTEM - EPA PHASE 2
(models produced prior to 1/1/2011)**

Ref. No.	Part No.	Description
1	462319	Fuel Tank Assembly
2	483536	Grommet
3	484243	Fuel Gauge Assembly
4	482571	Bushing, 0.56 Dia Viton
5	483555	Fuel Tube Assembly
6	483792	Fuel Cap
7	48059-01	Clamp, Fuel Hose 1/4"
8	483617	Fuel Hose, 1/4" ID Non-Perm (order by inch)
9	*	Fuel Filter
10	04001-08	Bolt, Hex Head 5/16-18 x 3/4"
11	04030-03	Lockwasher, 5/16" Spring
12	04040-15	Flatwasher, 5/16-.375 x .875 x .083

* = Available through engine manufacturer only.

SFZ48, SFZ52 & SFZ61 FUEL SYSTEM - EPA PHASE 3 (models produced after to 1/1/2011)

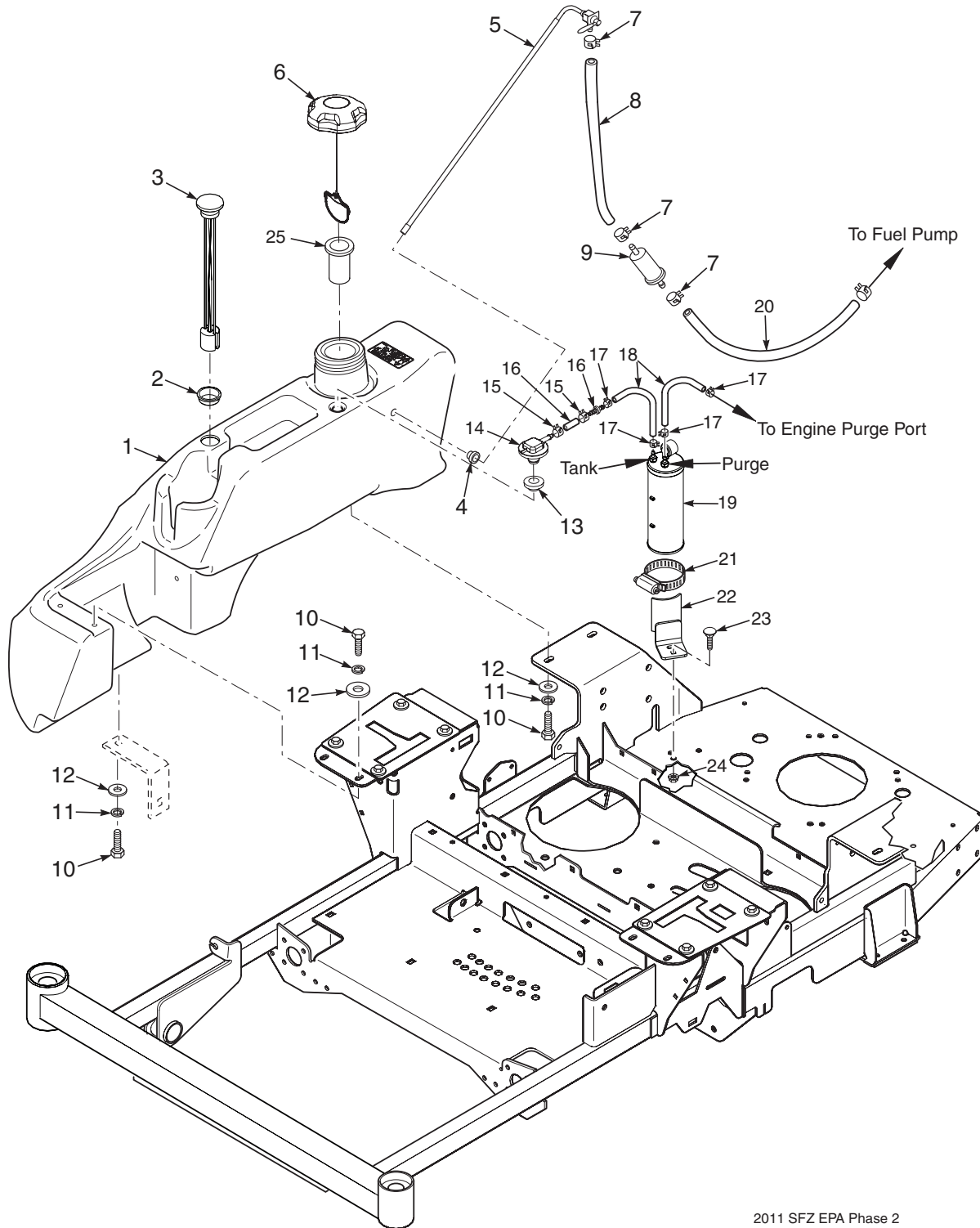

2011 SFZ EPA Phase 2

**SFZ48, SFZ52 & SFZ61 FUEL SYSTEM - EPA PHASE 3
(models produced after to 1/1/2011)**

Ref. No.	Part No.	Description
1	462292	Fuel Tank Assembly
2	483536	Grommet
3	484243	Fuel Gauge Assembly
4	482571	Bushing, .56 Dia. Viton
5	483555	Fuel Tube Assembly
6	484286	Fuel Cap, Tethered
7	48059-01	Clamp, Fuel Hose 1/4"
8	483617	Fuel Hose, 1/4" Non-Perm (order by inch)
9	*	Fuel Filter
10	04001-08	Bolt, Hex Head 5/16-18 x 3/4"
11	04030-03	Lockwasher, 5/16" Spring
12	04040-15	Flatwasher, 5/16-.375 x .875 x .083
13	484285	Grommet, Viton
14	484333	Remote Vent
15	48059-02	Clamp, Fuel Hose 7/32"
16	484347	Hose, 1/4" Vapor Recovery (order by inch)
17	48059-05	Clamp, Vapor Recovery Hose
18	484345	Hose, 3/16" (order by inch)
19	484342	Carbon Canister
20	*	Fuel Hose
21	48136-17	Clamp, Hose
22	452226	Bracket Weldment, SFZ48/52
	452233	Bracket Weldment, SFZ61
23	04003-12	Bolt, Carriage 5/16-18 x 3/4"
24	04019-03	Nut, Serrated Flange 5/16-18
25	484279-01	Tube, Fuel Tank Insert
26	484343-01	Mender, 1/4 x 3/16 w/0.02 Hole

* = Available through engine manufacturer only.

ZT-3100 HYDRAULIC AXLE ASSEMBLY

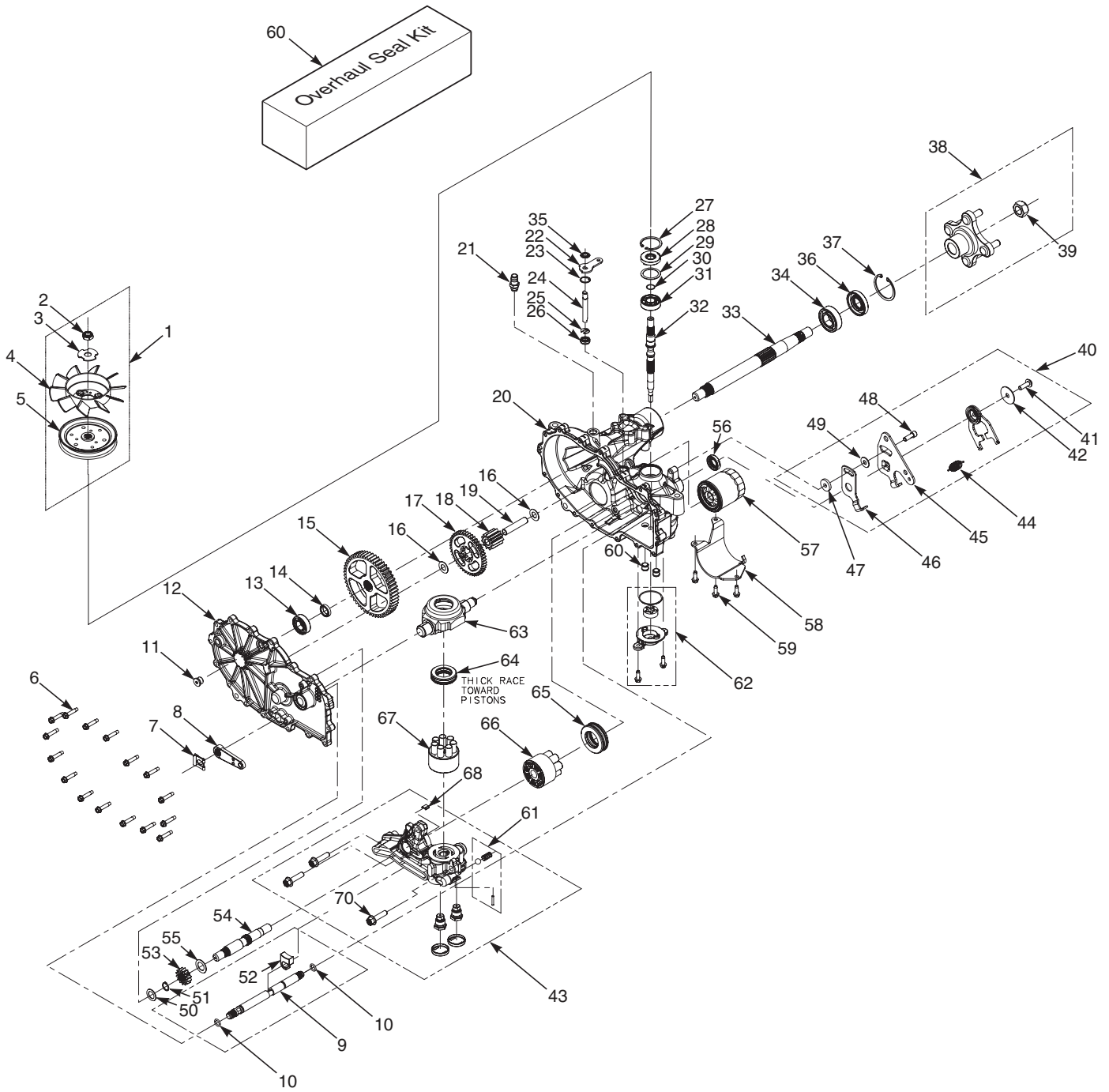

ZT-3100 HYDRAULIC AXLE ASSEMBLY

Ref. No.	Part No.	Description
1	HG71512	Kit, Fan & Pulley (SFZ36)
	HG70489	Kit, Fan & Pulley
2	HG51244	Nut, Hex Locking 1/2-20
3	HG51523	Washer, Slotted
4	HG52576	Fan, 7" Dai. (10 Blade) - (SFZ36)
	HG51862	Fan, 7" Dai. (10 Blade)
5	HG50302	Pulley, Cupped 4-1/2" Dia (SFZ36)
	HG52364	Pulley, Cupped 4-1/2" Dia
	HG52366	Hub, Pulley
6	HG51190	Bolt, Hex Head 1/4-20 x 1-11/4"
7	HG52027	Clip, Retaining
8	HG52639	Handle, Brake
9	HG52640	Shaft, Brake
10	HG51804	O-Ring
11	HG9005110-5600	Plug, 9/16-18
12	HG71572	Kit, Side Cover RH
	HG71574	Kit, Side Cover LH
13	HG44121	Bearing, Ball .75 x 40 x 12
14	HG52161	Spacer, .75 x 1.0 x .257
15	HG52108	Gear, 54T
16	HG50132	Washer, .5 x 1.0 x .03
17	HG52148	Gear, 43T (SFZ36)
	HG52110	Gear, 45T
18	HG52586	Gear, 11T
19	HG51083	Jackshaft Pin
20	HG71413	Kit, Housing RH
	HG71421	Kit, Housing LH
21	482800-03	Fitting
22	HG51329	Arm, By-Pass
23	HG51627	Ring, Retaining .750 Internal
24	HG52136	Rod, By-Pass
25	HG51628	Ring, .Retaining .375 External
26	HG51626	Seal, Lip .375 x .75 x .25
27	HG50329	Ring, Retaining 2.06 Internal
28	HG51161	Seal, Lip 17 x 40 x 7
29	HG50951	Washer, 1.23 x 1.56 x .04
30	HG2000022	Ring, Retaining Wire
31	HG50315	Bearing, Ball 17 x 40 x 12 Open
32	HG52155	Shaft, Input
33	HG71570	Shaft Kit, Axle (SFZ36)
	HG71569	Shaft Kit, Axle
34	HG50771	Bearing, Ball 1.0 x 52 x 15 Open
35	HG51630	Ring, Retaining .375 External

Ref. No.	Part No.	Description
36	HG50772	Seal, Lip 25 x 52 x 10 TC Gray
37	HG50859	Ring, Retaining 2.06 Internal
38	HG71446	Hub Kit (SFZ36)
	HG71505	Hub Kit
39	HG50863	Nut, Hex Locking
40	HG71595	Kit, RTN Assembly
41	HG51812	Bolt, 5/16-24 x 1" Patch
42	HG51950	Washer, .343 x 1.5 x .062
43	HG71565	Kit, Center Section RH
	HG71566	Kit, Center Section LH
44	HG51605	Spring
45	HG52682	Arm, Control
46	HG51945	Arm, Neutral RH
	HG51946	Arm, Neutral LH
47	HG52527	Spacer, .320 x 1.005 x .179
48	HG51616	Bolt, 5/16-24 x 1" Patch
49	HG44130	Washer, .34 x .88 x .06
50	HG44371	Washer, .63 x 1.0 x .05
51	HG44145	Ring, Retaining
52	HG52641	Pawl, Brake
53	HG52344	Gear, 16T (SFZ36)
	HG52341	Gear, 14T
54	HG52150	Shaft, Motor
55	HG51069	Washer, .72 x 1.16 x .04
56	HG51140	Seal, Lip 18 x 32 x 7
57	HG52114	Filter
58	HG52257	Filter Guard
59	HG50752	Bolt, 1/4-20 x 3/4"
60	HG71410	Seal Kit
61	HG71436	Kit, Charge Relief
62	HG71411	Kit, Charge Pump
63	HG51048	Trunnion Washplate
64	HG50551	Thrust Bearing
65	HG51462	Thrust Bearing
66	HG71579	Kit, Motor Cylinder Block
67	HG70723	Kit, Cylinder Block
68	HG71448	Plate, By-Pass
69	HG71436	Kit, Charge Relief
70	HG52137	Bolt, Hex Head 3/8-16 x 1-1/2" Patch

ZT-3400 HYDRAULIC AXLE ASSEMBLY -SFZ61

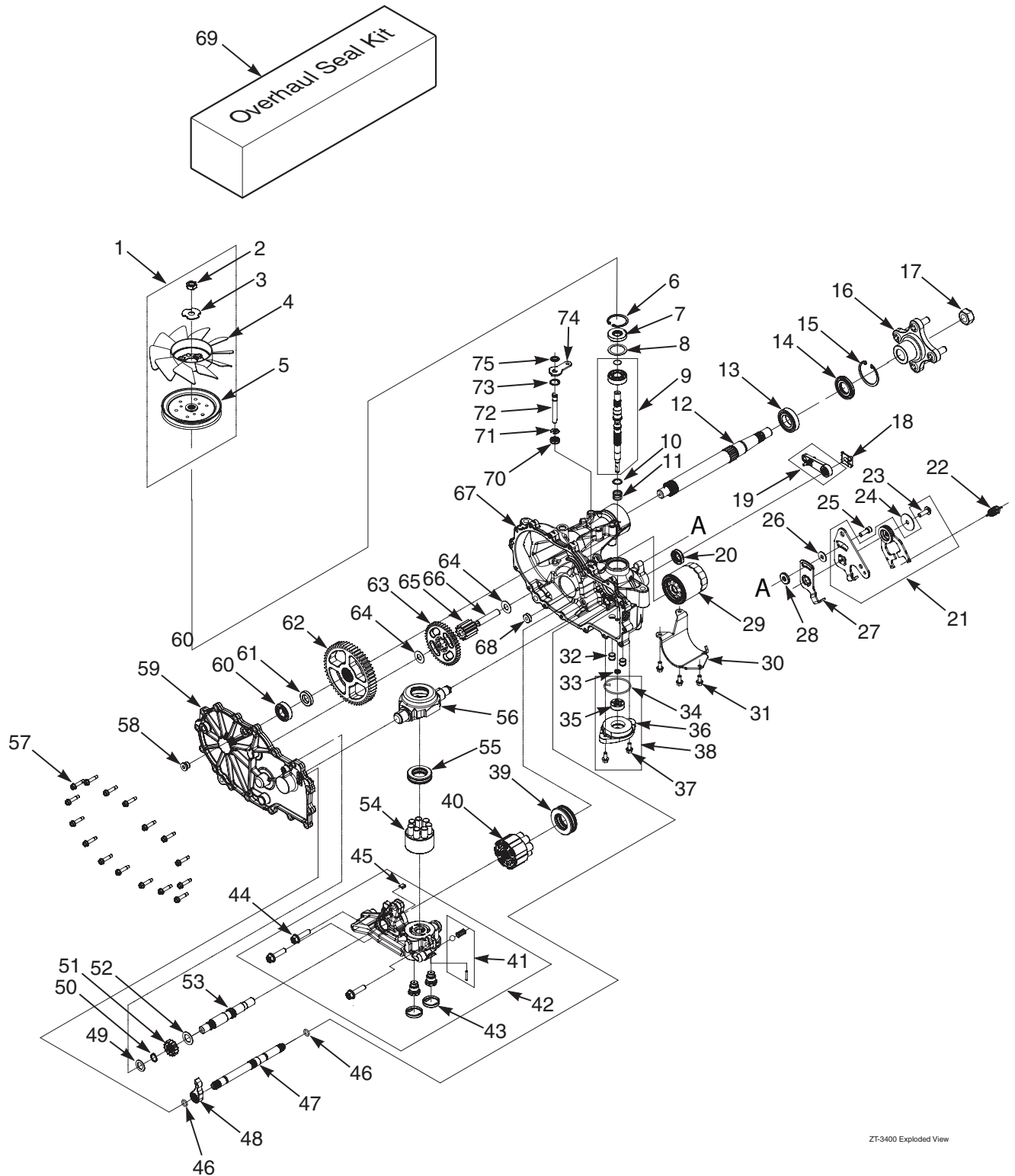

ZT-3400 HYDRAULIC AXLE ASSEMBLY - SFZ61

Ref. No.	Part No.	Description
1	HG72034	Kit, Fan & Pulley
2	HG44133	Nut, Elastic Stop 1/2-20
3	HG51523	Washer, OD Slotted .53 x 1.63 x .06
4	HG51862	Fan, 7" (10 Blade)
5	HG53619	Pulley, 4-1/2"
6	HG53029	Ring, Retaining
7	HG51161	Seal, Lip 17 x 40 x 7
8	HG50951	Washer, 1.23 x 1.56 x .04
9	HG71978	Kit, Input Shaft
10	HG2003017	Washer, Flat .59 x .79 x .04
11	HG2003014	Spring, Block
12	HG53528	Shaft, Axle
13	HG50771	Bearing, Ball 25.4 x 52 x 15
14	HG50772	Seal, Lip 1 x 2.049 x .375
15	HG50859	Ring, Retaining 2.06 Internal
16	HG71405	Hub, 4-Bolt
17	HG50863	Nut, Hex Lock 3/4-16
18	HG52027	Clip, Retaining
19	HG52639	Handle, Brake Actuating
20	HG51140	Seal, Lip 12 x 32 x 7
21	HG71595	Kit, RTN Bi-Directional (Left Side)
	HG71598	Kit, RTN Bi-Directional (Right Side)
22	HG51605	Spring, RTN
23	HG51812	Bolt, Hex Head Cap Screw 5/16-24 x 1" Patch
24	HG51950	Washer, .343 x 1.5 x .062
25	HG51616	Bolt, Hex Head Cap Screw 5/16-24 x 1" Patch
26	HG44130	Washer, .34 x .88 x .06
27	HG51945	Arm, Neutral (Right Side)
	HG51946	Arm, Neutral (Left Side)
28	HG52527	Spacer, .320 x 1.005 x .179
29	HG52114	Filter, Oil
30	HG52257	Guard, Filter (Right Side)
	HG52247	Guard, Filter (Left Side)
31	HG53464	Screw, Hex Flange 1/4-20 x .625
32	HG52157	Tibe, Connecting
33	HG53456	Seal, Lip 8 x 12 x 3-VC
34	HG52250	O-Ring, -.137 x .103 x 2.050
35	HG50273	Gerotor Assembly (1.9 cc)
36	HG53468	Cover, Charge Pump
37	HG53464	Screw, Hex Flange 1/4-20 x .625
38	HG71977	Kit, Charge Pump
39	HG51462	Bearing, Thrust

Ref. No.	Part No.	Description
40	HG71579	Assembly, Cylinger Block
41	HG71436	Kit, Charge Relief
42	HG71972	Kit, Center Section (Right Side)
	HG71973	Kit, Center Section (Left Side)
43	HG52162	Seal, Plug 1.250 x .250
44	HG52137	HFHCS, 3/8-16 X 1-1/2" Patch
45	HG51448	Plate, By-Pass
46	HG51804	O-Ring, -.111 x .103 x .424
47	HG42640	Shaft, Brake
48	HG52776	Pawl, Brake
49	HG44371	Washer, .63 x 1 x .05
50	HG44145	Ring, Retaining .625
51	HG52342	Gear, 13T Steel
52	HG51069	Washer, .72 x 1.16 x .04
53	HG52150	Shaft, Motor
54	HG71971	Assembly, Block 7 Piston
55	HG53502	Bearing, Thrust
56	HG51048	Trunnion, Swashplate
57	HG53246	HFHCS, 1/4-20 x 1-1/8"
58	HG9005110	Plug, 9/16-18
	-5600	
59	HG71990	Kit, Cover (Right Side)
	HG71992	Kit, Cover (Left Side)
60	HG44121	Bearing, Ball .75 x 40 x 12
61	HG53336	Spacer, .750 x 1.320 x .257
62	HG43327	Gear, 54T
63	HG52343	Gear, 46T
64	HG50132	Washer, .5 X 1 X .03
65	HG52586	Gear, 11T Steel
66	HG51083	Jackshaft Pin
67	HG72025	Kit, Housing Main (Right Side)
	HG72026	Kit, Housing Main (Left Side)
68	HG51100	Magnet, Ring
69	HG71976	Seal Kit
70	HG51626	Seal, Lip .375 x .75 x .25
71	HG51628	Ring, Retaining .375 External
72	HG52136	Rod, By-Pass
73	HG51677	Ring, Retaining .750 Internal
74	HG51629	Arm, By-Pass
75	HG51630	Ring, Retaining .375 External

REPLACEMENT DECALS AND INFORMATION PLATES

Ref. No.	Part No.	Description
1	483402	Decal, Belt Cover
2	483405	Decal, Warning
3	483425	Decal, ROPS
4	483505	Decal, Spinning Blades
5	481568	Decal, Traction Control
6	483633	Decal, Seat Replacement
7	483710	Decal, 36 Commercial
	483494	Decal, 48 Commercial
	483495	Decal, 52 Commercial
	484044	Decal, 61 Commercial
8	483406	Decal, Knives
9	483660	Decal, Adjustment SFZ
10	483695	Decal, Instrument Panel - SFZ36
	483499	Decal, Instrument Panel - SFZ48, SFZ52 & SFZ 61
11	483501	Decal, Front SFZ
12	483467	Decal, Cutting Height
13	483044	Decal, Patent
*	462155	Spanish Decal Kit - SFZ (not shown)
*	01411	DVD Video, Tips for Safe Operation of Your Scag Zero-Turn Mower (not shown)

ELECTRICAL SCHEMATIC

