

SCAG[®]

POWER EQUIPMENT

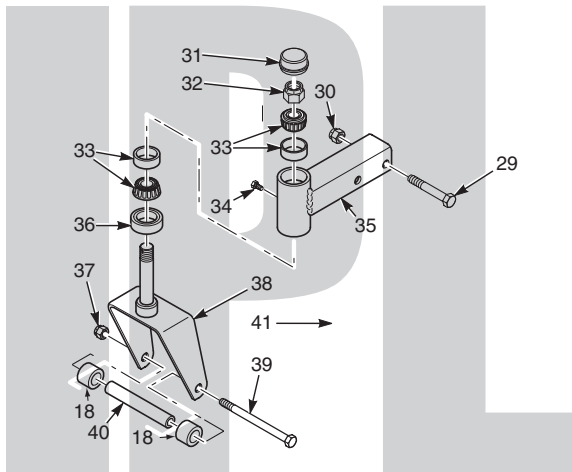

ILLUSTRATED PARTS MANUAL



Model SFZP Freedom Z Pro

THIS MANUAL CONTAINS THE ILLUSTRATED PARTS LIST FOR MODELS:

SFZP52-23FS
SFZ52P-25BS
SFZ61P-24FS
SFZP61-27BS

with a serial number of K8100000 to K8199999
with a serial number of K8200000 to K8299999
with a serial number of K8300000 to K8399999
with a serial number of K8400000 to K8499999

Table of Contents

52" CUTTER DECK.....	2
61" CUTTER DECK.....	4
CUTTER DECK CONTROLS - SFZP52.....	6
CUTTER DECK CONTROLS - SFZP61.....	8
SHEET METAL COMPONENTS SFZP.....	10
SEAT ASSEMBLY.....	12
NOTES.....	13
BRAKE COMPONENTS - SFZP.....	14
SFZP ROLL-OVER PROTECTION SYSTEM.....	16
DRIVE SYSTEM COMPONENTS - SFZP52 & SFZP61.....	18
EXHAUST AND ELECTRICAL SYSTEM - SFZP.....	20
SFZP FUEL SYSTEM.....	22
ZT-3100 HYDRAULIC AXLE ASSEMBLY - SFZP52.....	24
ZT-3400 HYDRAULIC AXLE ASSEMBLY - SFZP61.....	26
REPLACEMENT DECALS AND INFORMATION PLATES.....	28
SFZP - ELECTRICAL SCHEMATIC.....	30

52" CUTTER DECK

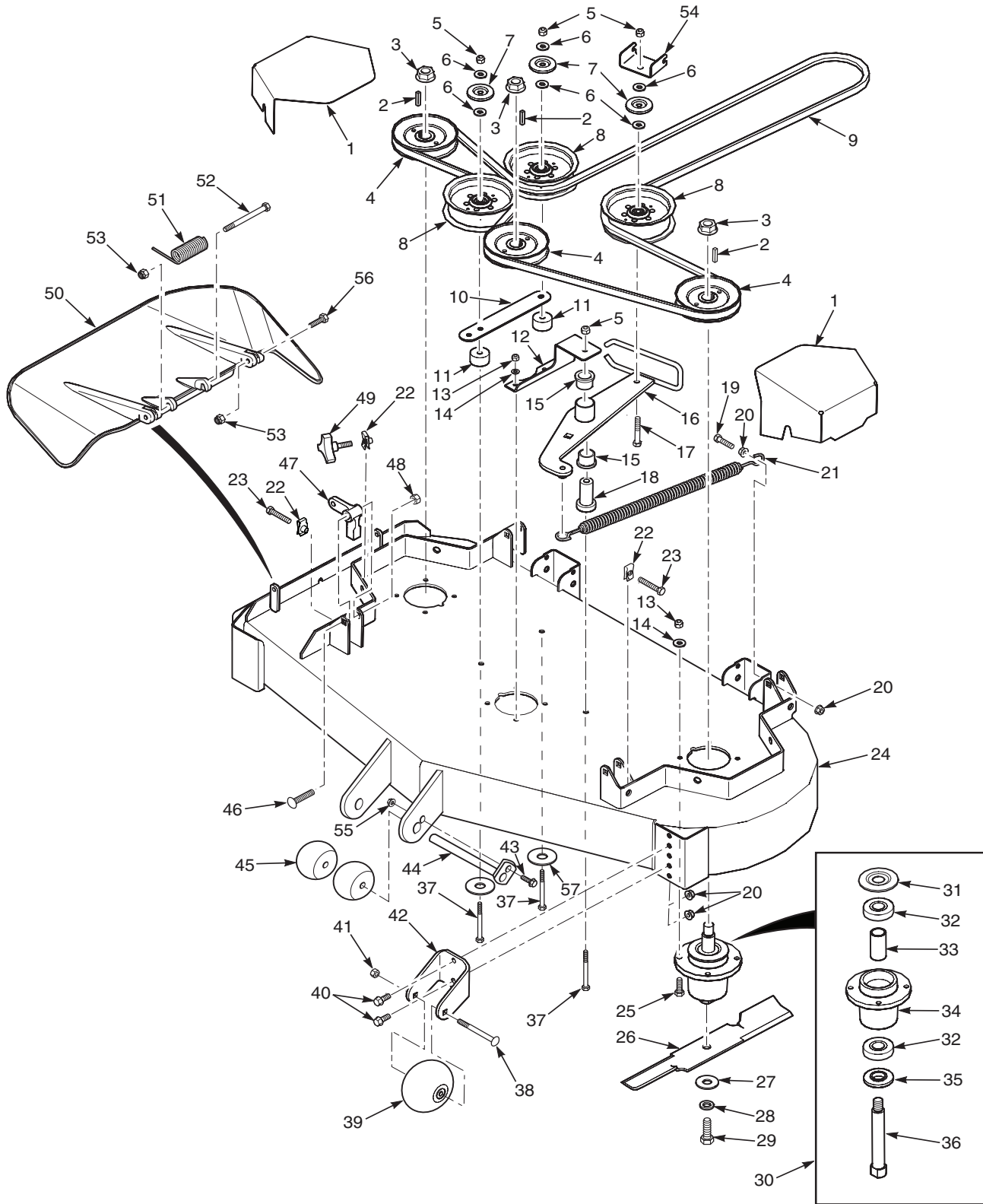

52" CUTTER DECK

	Part No.	Description
1	424528	Belt Cover
2	04063-01	Key, 1/4 x 1/4 x 1-1/4"
3	04112-06	Nut, 3/4-16 Spiral Lock
4	483324	Pulley, 5.73" OD - 25mm Bore
5	04021-09	Nut, Elastic Stop 3/8-16
6	04043-04	Flatwasher, 3/8-.391 x .938 x .105
7	424367	Dust Shield
8	483422	Pulley, 5" Idler
9	483326	Belt, Cutter Deck
10	424479	Brace, Pulley
11	43711	Spacer
12	424547	Support, Idler Pivot
13	04021-22	Nut, Elastic Stop
14	04030-03	Lockwasher, 5/16 Spring
15	483453-03	Bearing
16	462037	Idler Arm (incl. item #15)
17	04001-31	Bolt, Hex Head 3/8-16 x 2-1/2"
18	43708	Pivot, Idler
19	04001-136	Bolt, Hex Head 3/8-16 x 1-1/2 Gr.8
20	04019-04	Nut, Serrated Flange 3/8-16
21	483375	Spring, Idler
22	04110-03	U-Nut, 3/8-16
23	04107-04	Bolt, Hex Head 3/8-16 x 2"Special Lock
24	462040	Cutter Deck w/Decals, SFZ52
25	4001-11	Bolt, Hex Head 5/16-18 x 1-1/2"
26	482878	Cutter Blade, 18"
27	04043-06	Flatwasher, 5/8-.688 x 1.75 x .134 HD
28	04030-07	Lockwasher, 1/2 Spring
29	04001-121	Bolt, Hex Head 5/8-11 x 1-1/2"
30	461950	Spindle Assembly

	Part No.	Description
31	483304	Debris Shield
32	483303	Bearing
33	43693	Spacer
34	462014	Spindle Housing Assembly (Incl. item #32, 33)
35	43694	Protector, Bearing
36	43695	Shaft, Spindle
37	04001-77	Bolt, Hex Head 3/8-16 x 3-1/2"
38	04003-26	Bolt, Carriage 3/8-16 x 4"
39	481632	Wheel, Anti-Scalp
40	04017-27	Bolt, Hex Head 3/8-16 x 1" Ser. Fig.
41	04021-05	Nut, Center Lock 3/8-16
42	422478	Bracket, Anti-Scalp
43	04001-09	Bolt, Hex Head 5/16-18 x 1"
44	451926	Shaft Weldment
45	482295	Wheel, Anti-Scalp
46	04003-42	Bolt, Carriage 7/16-14 x 2-1/4"
47	483361	Lever, Deck Level
48	04021-11	Nut, Elastic Stop 7/16-14
49	481625-01	Knob w/Stud
50	462032	Discharge Chute Assy. SFZ52
*	462474	CA Discharge Chute, 52
51	482245	Spring, Discharge Chute
52	04001-154	Bolt, Hex Head 5/16-18 x 4-3/4"
53	04021-10	Nut, Elastic Stop 5/16-18
54	424615	Bracket, Belt Guide
55	04019-03	Nut, Serrated Flange 5/16-18
56	04001-12	Bolt, Hex Head 5/16-18 x 1-3/4"
57	04041-38	Flatwasher, 3/8-.406 x 2.25 x .1875
*	424211	Turbo Baffle

* = California Models Only (not shown)

61" CUTTER DECK

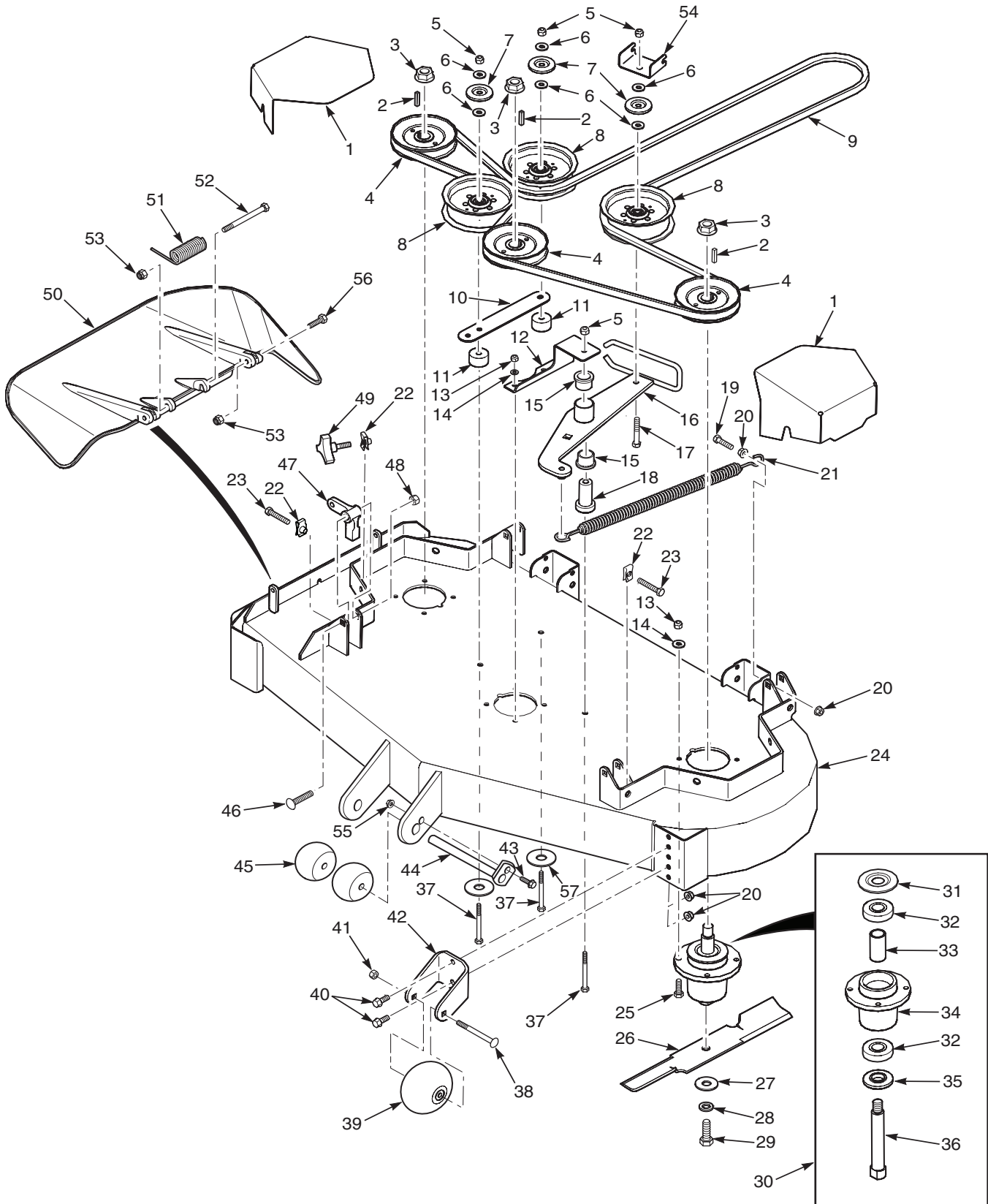

61" CUTTER DECK

	Part No.	Description
1	425260	Belt Cover
2	04063-01	Key, 1/4 x 1/4 x 1-1/4"
3	04112-06	Nut, 3/4-16 Spiral Lock
4	484026	Pulley, 6.32" OD - 25mm Bore
5	04021-09	Nut, Elastic Stop 3/8-16
6	04043-04	Flatwasher, 3/8-.391 x .938 x .105
7	424367	Dust Shield
8	483422	Pulley, 5" Idler
9	484031	Belt, Cutter Deck
10	424479	Brace, Pulley
11	43711	Spacer
12	425264	Support, Idler Pivot
13	04021-22	Nut, Elastic Stop
14	04030-03	Lockwasher, 5/16 Spring
15	483453-03	Bearing
16	462037	Idler Arm (incl. item #15)
17	04001-31	Bolt, Hex Head 3/8-16 x 2-1/2"
18	43708	Pivot, Idler
19	04001-136	Bolt, Hex Head 3/8-16 x 1-1/2 Gr.8
20	04019-04	Nut, Serrated Flange 3/8-16
21	483375	Spring, Idler
22	04110-03	U-Nut, 3/8-16
23	04107-04	Bolt, Hex Head 3/8-16 x 2" Special Lock
24	462227	Cutter Deck w/Decals, SFZ61
25	04001-11	Bolt, Hex Head 5/16-18 x 1-1/2"
26	482879	Cutter Blade, 21"
27	04043-06	Flatwasher, 5/8-.688 x 1.75 x .134 HD
28	04030-07	Lockwasher, 1/2 Spring
29	04001-121	Bolt, Hex Head 5/8-11 x 1-1/2"
30	461950	Spindle Assembly

	Part No.	Description
31	483304	Debris Shield
32	483303	Bearing
33	43693	Spacer
34	462014	Spindle Housing Assembly (Incl. item #32, 33)
35	43694	Protector, Bearing
36	43695	Shaft, Spindle
37	04001-77	Bolt, Hex Head 3/8-16 x 3-1/2"
38	04003-26	Bolt, Carriage 3/8-16 x 4"
39	481632	Wheel, Anti-Scalp
40	04017-27	Bolt, Hex Head 3/8-16 x 1" Ser. Flg.
41	04021-05	Nut, Center Lock 3/8-16
42	422478	Bracket, Anti-Scalp
43	04001-09	Bolt, Hex Head 5/16-18 x 1"
44	451926	Shaft Weldment
45	482295	Wheel, Anti-Scalp
46	04003-42	Bolt, Carriage 7/16-14 x 2-1/4"
47	483361	Lever, Deck Level
48	04021-11	Nut, Elastic Stop 7/16-14
49	481625-01	Knob w/Stud
50	462213	Discharge Chute Assembly
*	462476	CA Discharge Chute, 61
51	482245	Spring, Discharge Chute
52	04001-154	Bolt, Hex Head 5/16-18 x 4-3/4"
53	04021-10	Nut, Elastic Stop 5/16-18
54	424615	Bracket, Belt Guide
55	04019-03	Nut, Serrated Flange 5/16-18
56	04001-12	Bolt, Hex Head 5/16-18 x 1-3/4"
57	04041-38	Flatwasher, 3/8-.406 x 2.25 x .1875
*	425867	Turbo Baffle

* = California Models Only (not shown)

CUTTER DECK CONTROLS - SFZP52

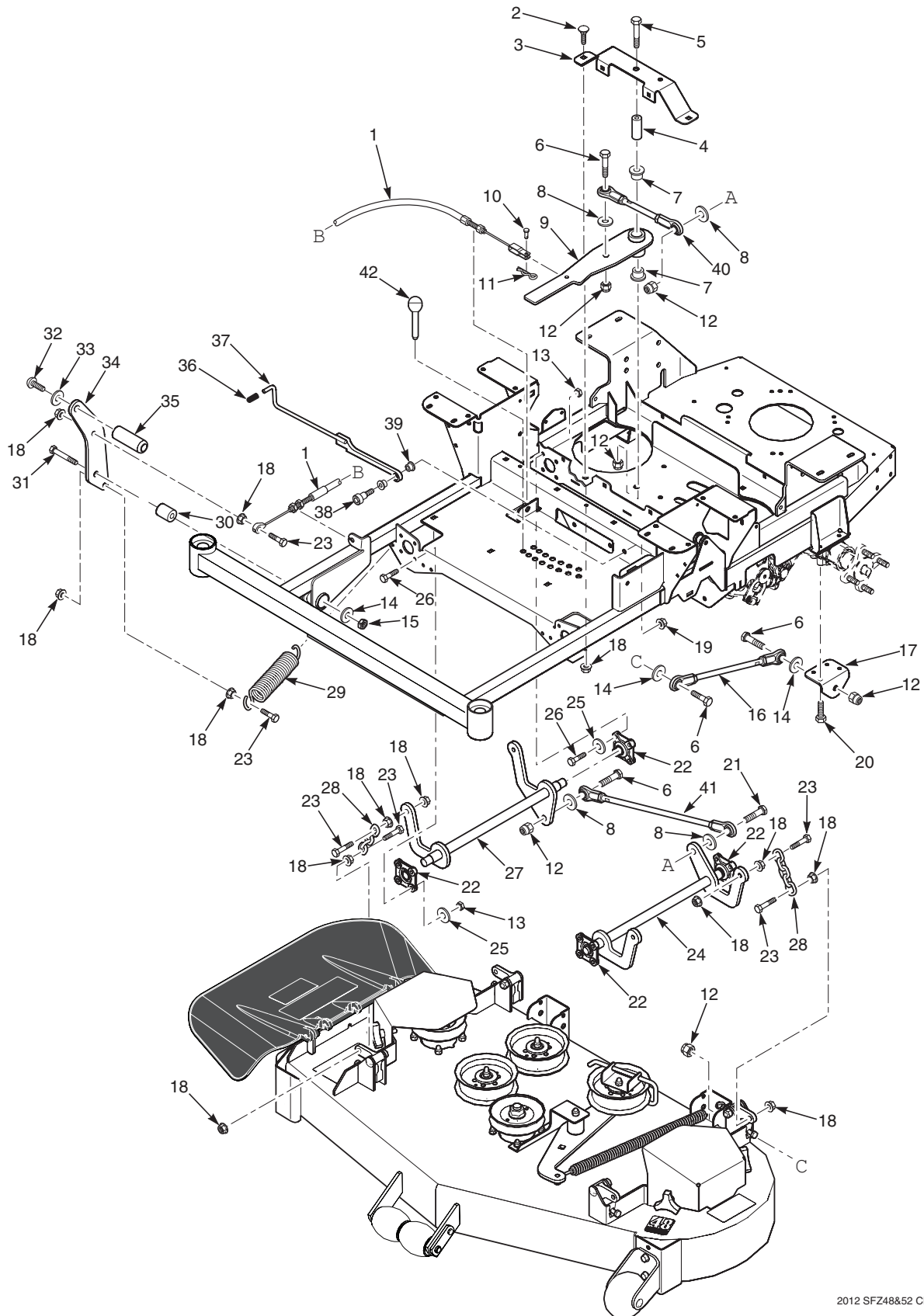

CUTTER DECK CONTROLS - SFZP52

Ref. No.	Part No.	Description
1	483341	Cable, Deck Lift
2	04003-31	Bolt, Carriage 3/8-16 x 3/4"
3	424476	Support, Idler Arm
4	43710	Spacer, Deck Lift Pivot
5	04001-90	Bolt, Hex Head 1/2-13 x 3-3/4"
6	04001-183	Bolt, Hex Head 1/2-13 x 1-3/4"
7	483453-03	Bearing
8	04040-07	Flatwasher, 1/2-.531 x 1.06 x .095
9	461999	Deck Lift Bellcrank Assembly
10	04064-17	Clevis Pin, 5/16 x 3/4"
11	04062-01	Hair Pin, .094 x 1.62"
12	04021-07	Nut, Elastic Stop 1/2-13
13	04021-10	Nut, Elastic Stop 5/16-18
14	04040-13	Flatwasher, 1/2-.562 x 1.375 x .109
15	04021-09	Nut, Center Lock 1/2-13
16	483332	Linkage, Push Arm
17	424489	Bracket, Push Arm Link
18	04019-04	Nut, Serrated Flange 3/8-16
19	04021-09	Nut, Elastic Stop 3/8-16
20	04001-49	Bolt, Hex Head 5/16-18 x 3"
21	04001-52	Bolt, Hex Head 1/2-13 x 2-1/2"
22	483334	Bearing, Deck Lift
23	04001-20	Bolt, Hex Head 3/8-16 x 1-1/2"
24	451868	Weldment, Deck Lift LH
25	04040-14	Flatwasher, 1/4-.312 x .750 x .065
26	04001-09	Bolt, Hex Head 5/16-18 x 1"
27	451867	Weldment, Deck Lift RH
28	482628	Chain, Deck lift
29	483374	Spring, Deck Lift
30	43710	Sleeve, Deck Lift Pivot
31	04001-74	Bolt, Hex Head 1/2-13 x 3"
32	04105-01	Bolt, Head Socket 5/8-11 x 1-1/2"
33	04030-07	Lockwasher, 5/8 Spring
34	424535	Pedal, Foot Bracket
35	424504	Foot Pedal
36	483492	Grip, Deck Latch
37	491254	Weldment, Deck Latch
38	04009-06	Bolt, Shoulder 1/2 x 1/2
39	483453-10	Bearing
40	483328	Linkage Assembly, Deck Lift
41	483367	Linkage Assembly, Deck Lift
42	483498	Pin, Height Adjuster

CUTTER DECK CONTROLS - SFZP61

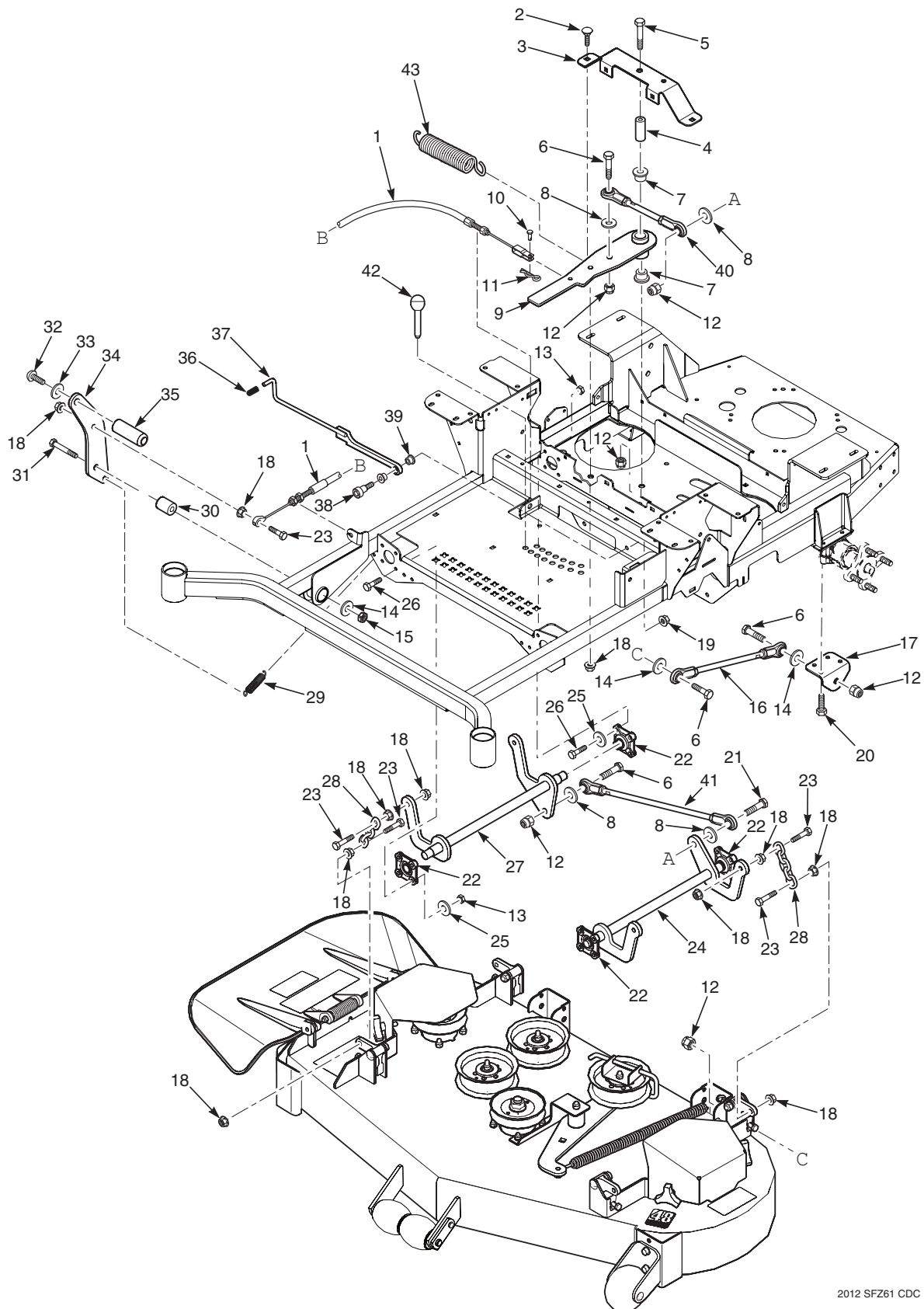

CUTTER DECK CONTROLS - SFZP61

Ref. No.	Part No.	Description
1	483341	Cable, Deck Lift
2	04003-31	Bolt, Carriage 3/8-16 x 3/4"
3	424476	Support, Idler Arm
4	43710	Spacer, Deck Lift Pivot
5	04001-90	Bolt, Hex Head 1/2-13 x 3-3/4"
6	04001-183	Bolt, Hex Head 1/2-13 x 1-3/4"
7	483453-03	Bearing
8	04040-07	Flatwasher, 1/2-.531 x 1.06 x .095
9	461999	Deck Lift Bellcrank Assembly
10	04064-17	Clevis Pin, 5/16 x 3/4"
11	04062-01	Hair Pin, .094 x 1.62"
12	04021-07	Nut, Elastic Stop 1/2-13
13	04021-10	Nut, Elastic Stop 5/16-18
14	04040-13	Flatwasher, 1/2-.562 x 1.375 x .109
15	04021-09	Nut, Center Lock 1/2-13
16	483332	Linkage, Push Arm
17	424489	Bracket, Push Arm Link
18	04019-04	Nut, Serrated Flange 3/8-16
19	04021-09	Nut, Elastic Stop 3/8-16
20	04001-49	Bolt, Hex Head 5/16-18 x 3"
21	04001-52	Bolt, Hex Head 1/2-13 x 2-1/2"
22	483334	Bearing, Deck Lift
23	04001-20	Bolt, Hex Head 3/8-16 x 1-1/2"
24	452112	Weldment, Deck Lift LH
25	04040-14	Flatwasher, 1/4-.312 x .750 x .065
26	04001-09	Bolt, Hex Head 5/16-18 x 1"
27	452113	Weldment, Deck Lift RH
28	482628	Chain, Deck lift
29	484038	Spring, Deck Lift
30	43710	Sleeve, Deck Lift Pivot
31	04001-74	Bolt, Hex Head 1/2-13 x 3"
32	04105-01	Bolt, Head Socket 5/8-11 x 1-1/2"
33	04030-07	Lockwasher, 5/8 Spring
34	424844	Pedal, Foot Bracket
35	424504	Foot Pedal
36	483492	Grip, Deck Latch
37	491254	Weldment, Deck Latch
38	04009-06	Bolt, Shoulder 1/2 x 1/2
39	483453-10	Bearing
40	483328	Linkage Assembly, Deck Lift
41	483367	Linkage Assembly, Deck Lift
42	483498	Pin, Height Adjuster
43	483374	Spring, Deck Lift

SHEET METAL COMPONENTS SFZP

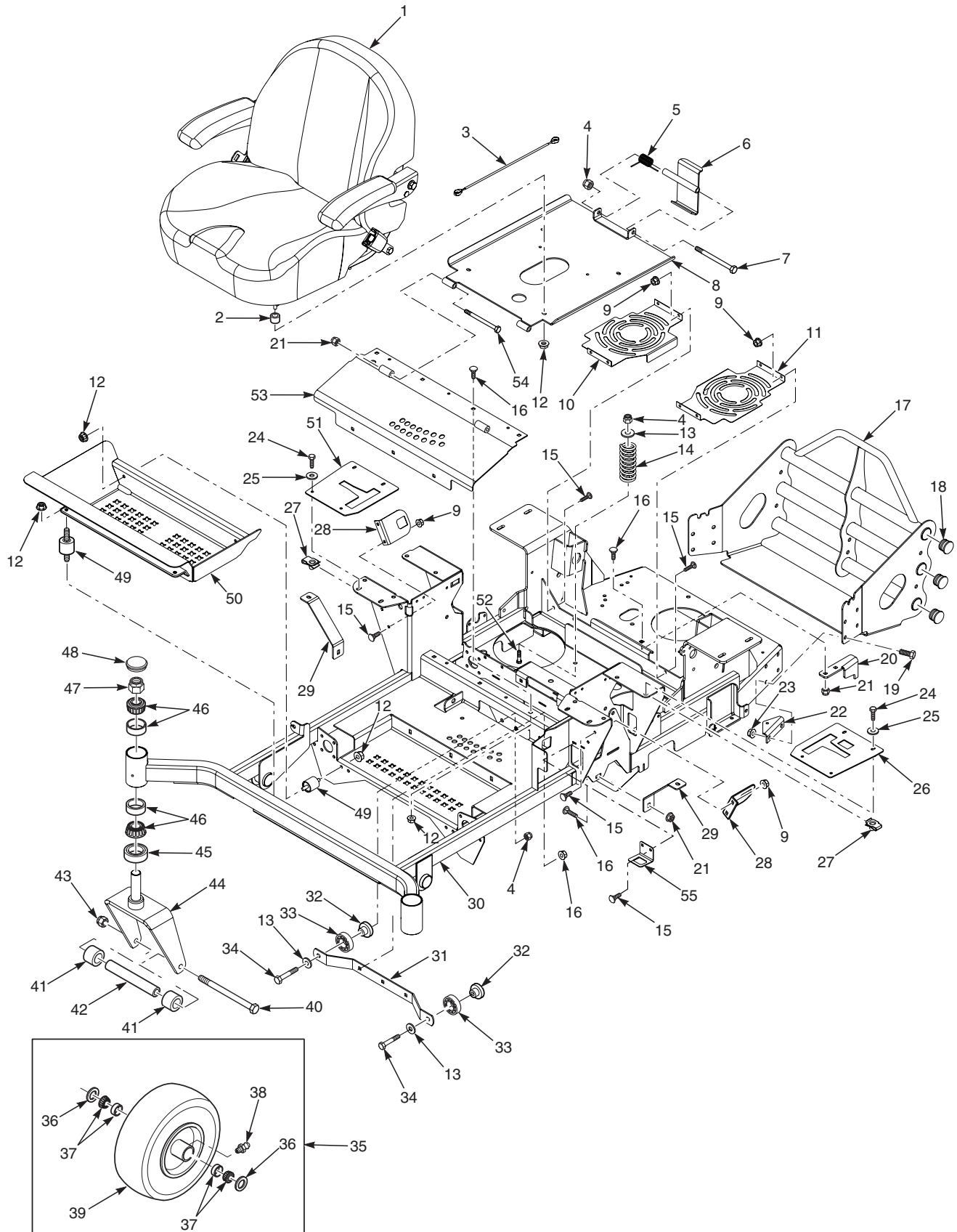

SHEET METAL COMPONENTS - SFZP

	Part No.	Description
1	484375	Seat Assembly
2	43336	Spacer
3	483559	Cable, Seat Stop
4	04021-09	Nut, Elastic Stop 3/8-16
5	483371	Spring, Seat Latch
6	451883	Weldment, Seat Latch
7	04001-100	Bolt, Hex Head 3/8-16 x 6"
8	452264	Seat Plate Weldment
9	04019-02	Nut, Serrated Flange 1/4-20
10	425698	Fan Cover, RH
11	425697	Fan Cover, LH
12	04019-03	Nut, Serrated Flange 5/16-18
13	04041-07	Flatwasher, 3/8-.391 x .938 x .105
14	483372	Spring, Seat
15	04003-07	Bolt, Carriage 1/4-20 x 1"
16	04003-12	Bolt, Carriage 5/16-18 x 3/4"
17	452334	Bumper Weldment
18	483535	Plug, Bumper Tube
19	04001-19	Bolt, Hex Head 3/8-16 x 1"
20	425696	Anti-Rotation Bracket
21	04021-10	Nut, Elastic Stop 5/16-18
22	424639	Bracket, Dump Valve
23	04019-04	Nut, Serrated Flange 3/8-16
24	04001-14	Bolt, Hex Head 1/4-20 x 1"
25	04040-14	Flatwasher, 1/4-.312 x .750 x .065
26	462483	Control Plate w/Decal, LH
27	04110-01	U-Nut, 1/4-20
28	424511	Bracket, Switch Mount
29	425890	Bracket, Tank Mount, SFZ52
	425700	Bracket, Tank Mount, SFZ61

Ref. No.	Part No.	Description
30	462520	Mainframe Assy., w/Decals - SFZ52
	462443	Mainframe Assy., w/Decals - SFZ61
31	424480	Support, Deck Guide
32	43703	Spacer, Bearing
33	483379	Bearing
34	04001-31	Bolt, Hex Head 3/8-16 x 2-1/2"
35	482503	Wheel Assembly
36	482622	Seal
37	482621	Bearing
38	48114-04	Fitting, Grease
39	481613	Tire, 13 x 5-6
	482625	Rim
40	04001-134	Bolt, Hex Head 1/2-13 x 7-1/2"
41	43584	Spacer, Caster Wheel
42	43581	Sleeve, Caster Wheel
43	04021-07	Nut, Elastic Stop 1/2-13
44	451471	Yoke Weldment
45	481025	Seal, 2" OD x 1.625 ID
46	48668	Bearing Set
47	04021-20	Nut, Elastic Stop 1"-14
48	484195	Grease Cap
49	483493	Rubber Isolator
50	451889	Footplate Weldment, SFZ52
	452263	Footplate Weldment, SFZ61
51	462484	Control PLate w/Decal, RH
52	04003-11	Bolt, Carriage 3/8-16 x 1-1/4"
53	462458	Deck Lift Cover w/Decal, SFZ52
	462369	Deck Lift Cover w/Decal, SFZ61
54	04001-73	Bolt, Hex Head 5/16-18 x 3-3/4"
55	425889	Switch Bracket

SEAT ASSEMBLY

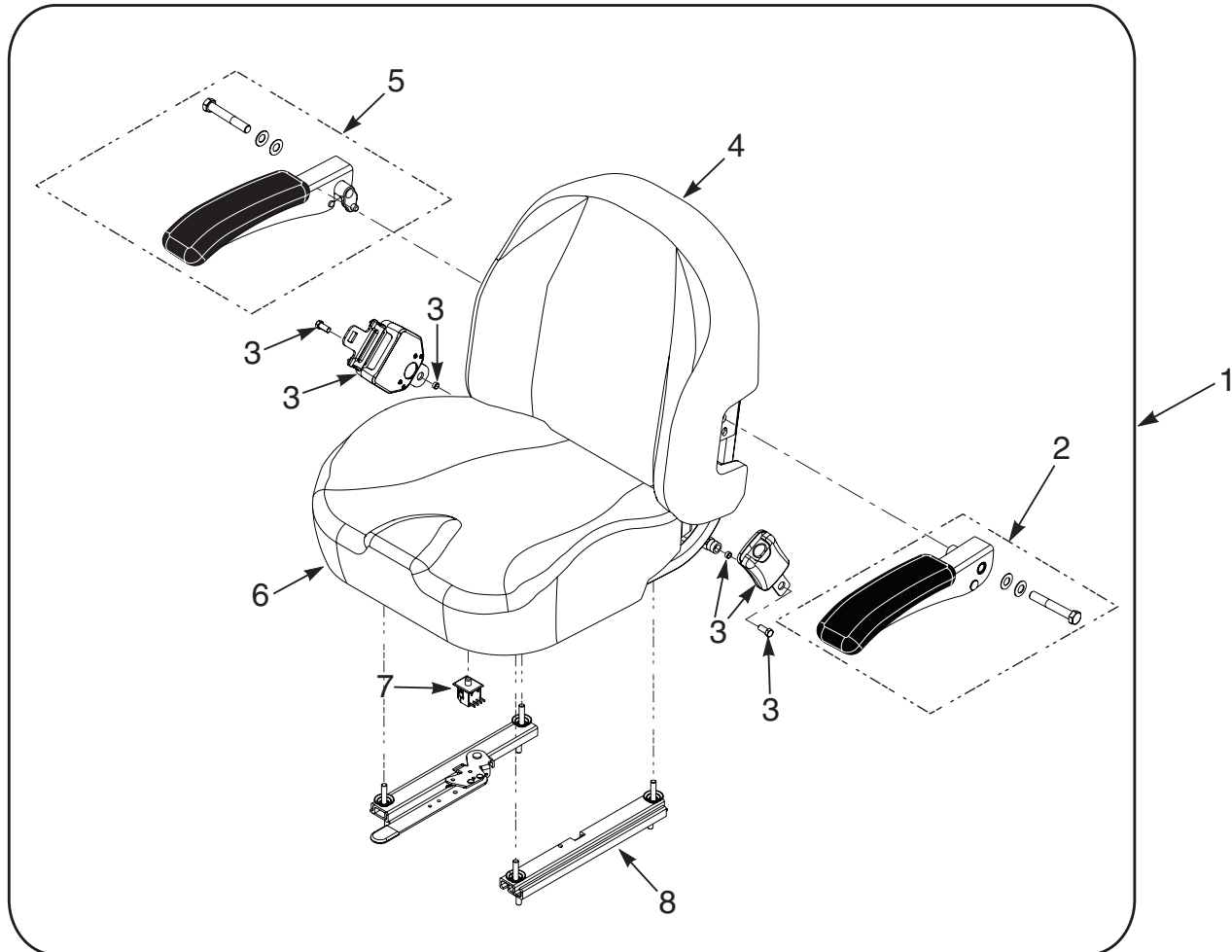

Ref. No.	Part No.	Description
1	484375	Seat Assembly
2	484260	Armrest Kit, LH
3	484527	Seatbelt Kit
4	484528	Back Cover
5	484261	Armrest Kit, RH
6	484529	Cushion Cover
7	483473	Switch
8	484526	Track Set

NOTES

BRAKE COMPONENTS - SFZP

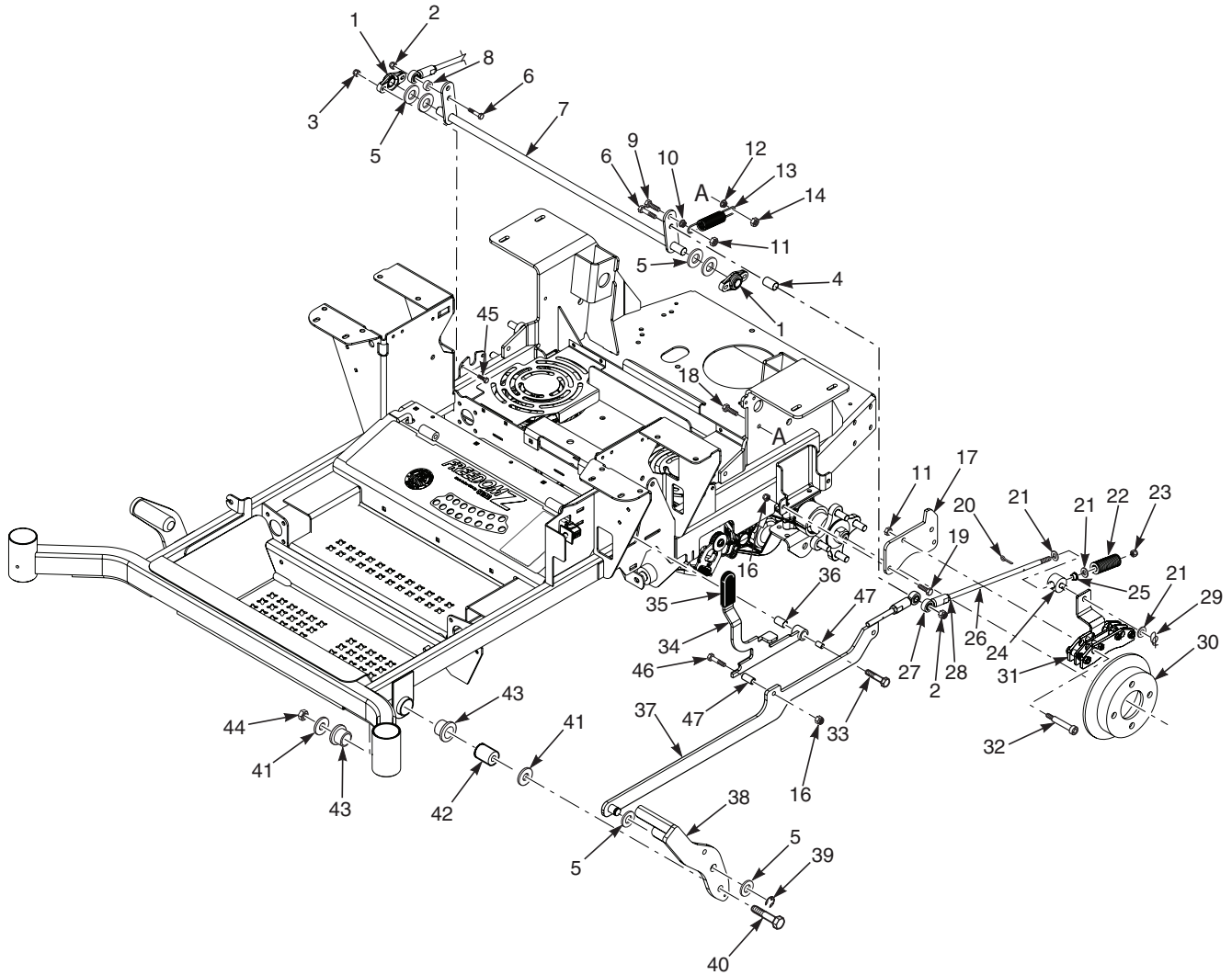

BRAKE COMPONENTS - SFZP

Ref. No.	Part No.	Description
1	483504	Bearing
2	04021-09	Nut, Elastic Stop 3/8-16
3	04021-08	Nut, Elastic Stop 1/4-20
4	43720	Spacer
5	04040-09	Flatwasher, 5/8-.656 x 1.312 x .095
6	04001-46	Bolt, Hex Head 3/8-16 x 2-1/4"
7	452269	Weldment, Brake Lever
8	43674	Spacer
9	04001-32	Bolt, Hex Head 3/8-16 x 1-1/4"
10	04019-04	Nut, Serrated Flange 3/8-16
11	04021-05	Nut, Center Lock 3/8-16
12	04019-03	Nut, Serrated Flange 5/16-18
13	484038	Spring
14	04021-04	Nut, Center Lock 5/16-18
15	04041-07	Flatwasher, 3/8-.391 x .938 x .105
16	04021-10	Nut, Elastic Stop 5/16-18
17	425680	Mounting Bracket, Brake
18	04001-10	Bolt, Hex Head 5/16-18 x 1-1/4"
19	04001-09	Bolt, Hex Head 5/16-18 x 1"
20	04061-02	Cotter Pin, 3/32 x 3/4"
21	04040-05	Flatwasher, 3/8-.406 x .812 x .065
22	484535	Spring, Brake
23	04021-18	Nut, Elastic Stop 3/8-24
24	462452	Swivel Assembly, Brake
25	483453-23	Bearing
26	04004-54	Link, Brake
27	482330	Rod End
28	04020-25	Nut, 3/8-24 UNF Jam
29	04069-01	Pin, Rue Cotter - 3/8" Dia.
30	43853	Brake Hub
31	483701	Brake Caliper
32	04009-17	Bolt, Shoulder 1/2 x 2-1/2"
33	04009-16	Bolt, Shoulder 1/2 x 2"
34	462485	Latch Assembly, Brake (incl. # 35, #36)
35	482102	Grip, Brake Lever
36	483453-22	Bearing
37	462419	Linkage Weldment Assembly, Brake
38	452278	Brake Pedal Weldment
39	04050-01	Retaining Ring, .625 Ext. "E"
40	04001-74	Bolt, Hex Head 1/2-13 x 3"
41	04040-13	Flatwasher, 1/2-.562 x 1.375 x .109
42	43710	Sleeve
43	483453-03	Bearing
44	04021-19	Nut, Center Lock 1/2-13
45	04001-14	Bolt, Hex Head 1/4-20 x 1"
46	04001-12	Bolt, Hex Head 5/16-18 x 1-3/4"
47	43866	Sleeve, Handle Pivot

SFZP ROLL-OVER PROTECTION SYSTEM

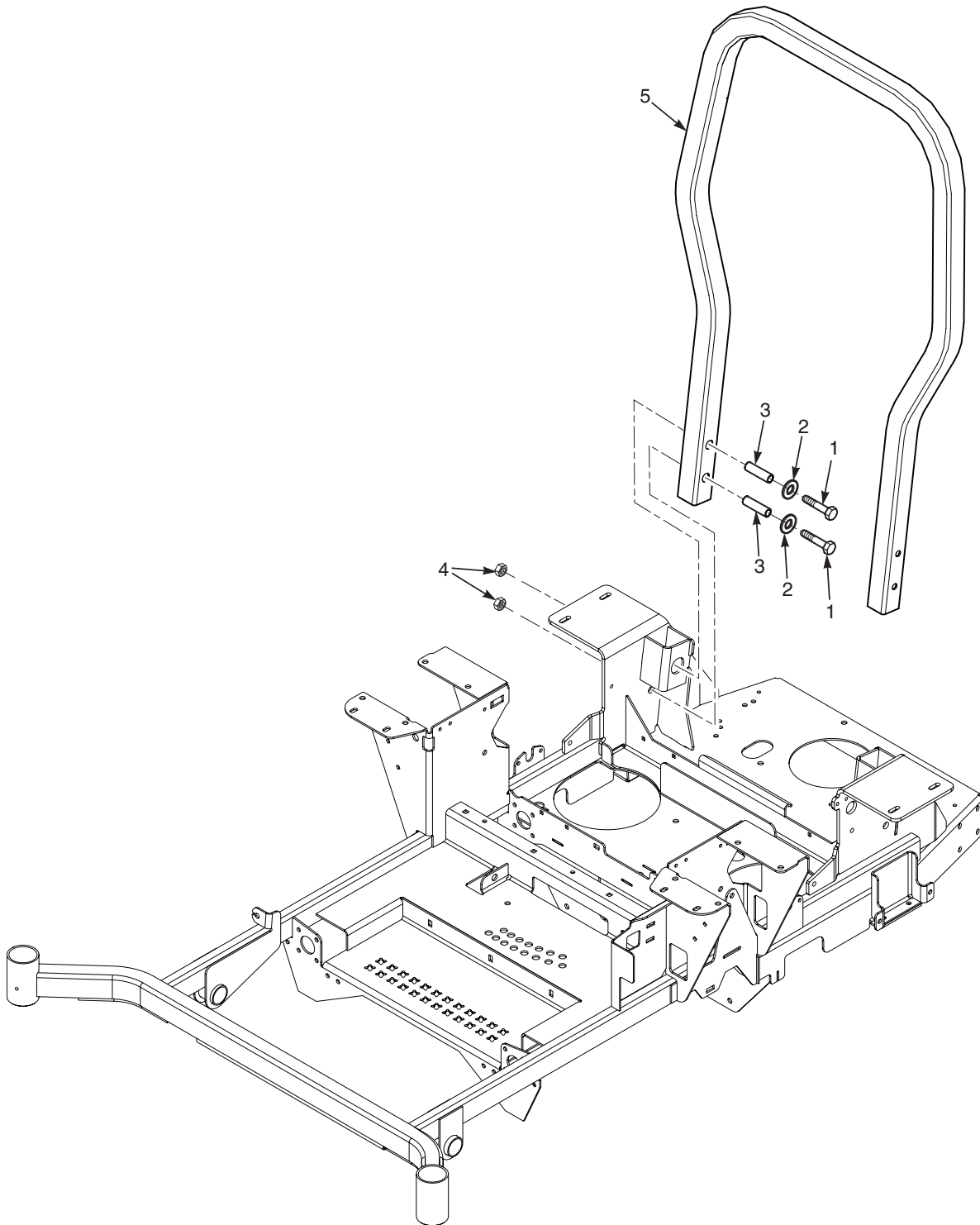

SFZP ROLL-OVER PROTECTION SYSTEM

Ref. No.	Part No.	Description
1	04001-197	Bolt, Hex Head 1/213 x 3" Gr. 8
2	04040-07	Flatwasher, 1/2 - .531 x 1.062 x .095
3	43743	Bushing, SFZ ROPS
4	04117-04	Nut, Flanged Elastic Stop, 1/2-13
5	462021	ROPS

DRIVE SYSTEM COMPONENTS - SFZP52 & SFZP61

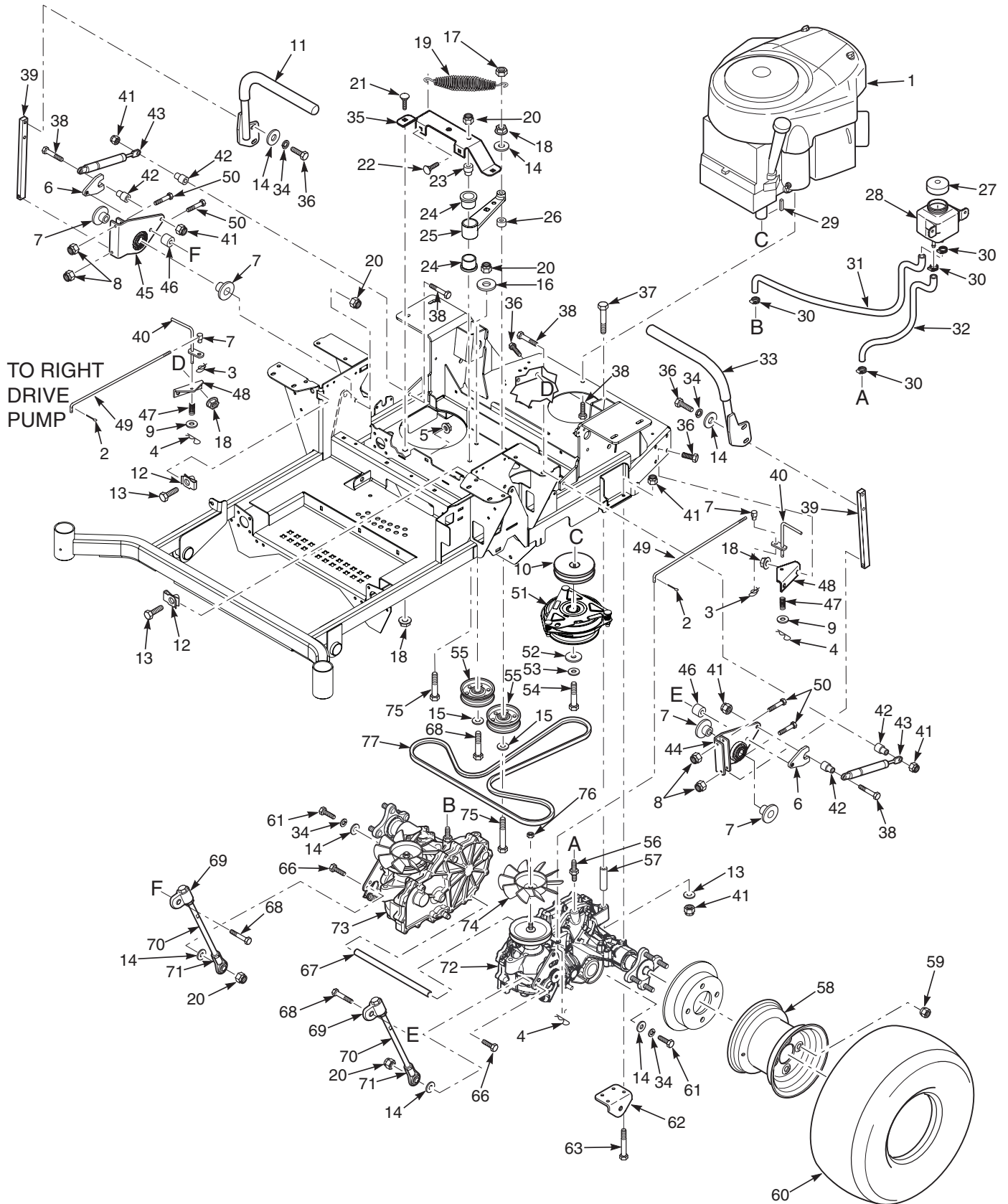

DRIVE SYSTEM COMPONENTS - SFZP52 & SFZP61

Ref. No.	Part No.	Description
1	485026	Engine, Briggs & Stratton - 25HP Pro
	485025	Engine, Kawasaki - 23FS
	485028	Engine, Briggs & Stratton - 27HP Pro
	485027	Engine, Kawasaki - 24FS
2	04061-01	Cotter Pin, 3/32 x 1"
3	04069-01	Pin, Rue Cotter 3/8" Dia.
4	04062-02	Hair Pin, .080 x 1.19"
5	04019-03	Nut, Serrated Flange 5/16-18
6	424687	Nut, Control Link
7	43719	Spacer, Linkage
8	04021-08	Nut, Elastic Stop 1/4-20
9	04040-14	Flatwasher, 1/4-.312 x .750 x .065
10	484646	Pulley, 4-1/2" OD - 1.125 Bore (SFZ52)
	484373	Pulley, 5" OD - 1.125 Bore (SFZ61)
11	462371	Handle Bar w/Grip
	484376	Grip
12	04110-03	U-Nut, 3/8-16
13	04107-01	Bolt, Hex Head 3/8-16 x 1-1/4" Special Lock
14	04041-07	Flatwasher, 3/8-.391 x .938 x .105
15	04043-04	Flatwasher, 3/8-.391 x .938 x .105 HD
16	04041-11	Flatwasher, 3/8-.406 x 1.5 x 7 GA.
17	04021-05	Nut, Center Lock 3/8-16
18	04019-04	Nut, Serrated Flange 3/8-16
19	483087	Spring, Transmission Idler
20	04021-09	Nut, Elastic Stop 3/8-16
21	04003-31	Bolt, Carriage 3/8-16 x 3/4"
22	04003-12	Bolt, Carriage 5/16-18 x 3/4"
23	43715	Shaft Pivot, Idler Arm
24	483453-04	Bearing
25	462122	Transmission Idler Arm Assembly
26	43674	Spacer, Idler Pulley - SFZ52
	43720	Spacer, Idler Pulley - SFZ61
27	483514	Cap
28	483438	Reservoir Assembly
29	04063-24	Key, 1/4 x 1/4 x 2-3/4"
30	48136-05	Clamp, 0.87" Max Dia.
31	483431	Hose, RH Transmission
32	483432	Hose, LH Transmission
33	462370	Handle Bar Assembly, w/Grip
	484376	Grip
34	04030-04	Lockwasher, 3/8" Spring
35	424476	Support, Idler Arm
36	04001-19	Bolt, Hex Head 3/8-16 x 1"
37	04001-95	Bolt, Hex Head 5/16-18 x 5"
38	04001-11	Bolt, Hex Head 5/16-18 x 1-1/2"
39	424498	Bar, Control Lever
40	451912	Dump Valve Lever
41	04021-10	Nut, Elastic Stop 5/16-18
42	43602	Spacer, Pump Dampener
43	484151	Dampener
44	462127	Control Link, LH
45	462128	Control Link, RH
46	43674	Spacer
47	482070	Spring
48	424639	Bracket, Dump Mounting

Ref. No.	Part No.	Description
49	44162	Linkage, Dump Valve
50	04001-04	Bolt, Hex Head 1/4-20 x 1-1/2"
51	462228	Electric Clutch Assembly - SFZ52 & SFZ61
52	04041-28	Flatwasher, 7/16-.469 x 1.75 x .25
53	04041-28	Lockwasher, 7/16" spring
54	04102-08	Bolt, Hex Head 7/16-20 x 1-1/2" Patch SFZ-61
55	483638	Pulley, 3-1/2" Dia.
56	482800-02	Fitting, Transmission - SFZ52
	482800-04	Fitting, Transmission - SFZ61
57	43700	Spacer, Axle - SFZ52
	43857	Spacer, Axle - SFZ61
58	481659	Rim w/Valve Stem (52)
	482414	Rim w/Valve Stem (61)
59	04028-02	Wheel Nut, 1/2-20
60	484554	Wheel Assembly, 22 x 9.5-12 (SFZ52)
	484555	Tire, 22 x 9.5-12 (SFZ52)
	481659	Rim (SFZ52)
	484465	Wheel Assembly, 23 x 9.5-12 (SFZ61)
	484466	Tire, 23 x 9.5-12 (SFZ61)
	484056	Rim (SFZ61)
61	04001-46	Bolt, Hex Head 3/8-16 x 2-1/4"
62	424489	Bracket, Pusharm Link
63	04001-49	Bolt, Hex Head 5/16-18 x 3"
64	*	Clip, Brake Lever (order through Hydro-Gear)
65	*	Lever, Brake (order through Hydro-Gear)
66	04001-32	Bolt, Hex Head 3/8-16 x 1-1/4"
67	43701	Spacer, Axle
68	04001-45	Bolt, Hex Head 3/8-16 x 2"
69	483563	Rod End, Adjustable 3/8-24
	04020-25	Nut, Jam 3/8-24 UNF RH
70	483668	Linkage, Pump - SFZ52
	484405	Linkage, Pump - SFZ61
71	483575	Stake, Rod End Assembly
72	484449	Transaxle Assy., LH (ZL-KCEF-3LKG-1NXX)
		SFZ52
	484454	Transaxle Assy., LH (ZS-KCEE-3LKG-11XX)
		SFZ61
	484450	Transaxle Assy., RH (ZL-GCEF-3LKG-1NXX)
73		SFZ52
	484455	Transaxle Assy., RH (ZS-GCEE-3LKF-11XX)
		SFZ61
74	*	Fan (order through Hydro-Gear)
75	04001-54	Bolt, Hex Head 3/8-16 x 3"
76	*	Fan Nut (order through Hydro-Gear)
77	483314	Belt, Transmission Drive - SFZ52
	484372	Belt, Transmission Drive - SFZ61

EXHAUST AND ELECTRICAL SYSTEM - SFZP

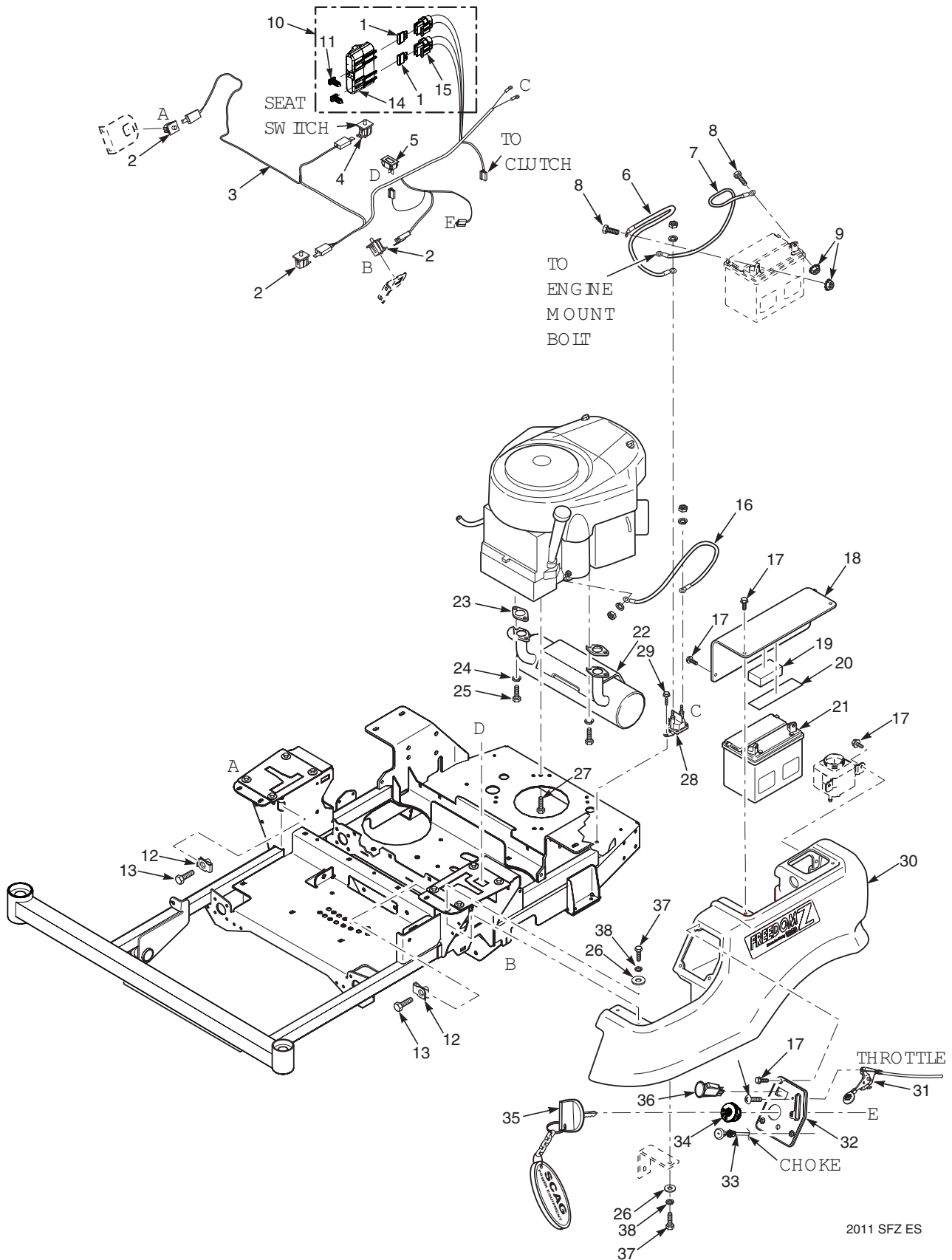

2011 SFZ ES

EXHAUST AND ELECTRICAL SYSTEM - SFZP

Ref. No.	Part No.	Description
1	48298	Fuse, 20 amp
2	483473	Switch
3	484433	Wire Harness, Main
	483529	Wire Harness Adapter, Kawasaki (not shown)
4	483474	Switch, Seat
5	484565	Hourmeter
6	48029-13	Battery Cable, Red 25"
7	48029-11	Battery Cable, Black 27"
8	04001-44	Bolt, Hex Head 1/4-20 x 1/2"
9	04020-02	Nut, 1/4-20
10	483642	Double Fuse Assy. (incl. items 1, 14, 15, 46)
11	482588	Clip, Wire
12	04110-03	U-Nut, 3/8-16
13	04107-03	Bolt, Hex Head 3/8-16 x 1-1/4" Special Lock
14	483571	Cover, Sealed Double
15	483629	Fuse Holder
16	48029-09	Battery Cable, Red 9"
17	04017-04	Bolt, Hex Head 1/4-20 x 1/2" Serr. Flange
18	461996	Battery Cover (incl. items 19 & 20)
19	483452	Pad, Battery Hold Down
20	483508	Rubber Pad
21	483665	Battery (not avail. through Scag)
22	483381	Muffler, Briggs & Stratton
	484209	Muffler, Kawasaki
23	**	Exhaust Gasket
24	**	Lockwasher
25	**	Bolt
26	04040-15	Flatwasher, 5/16-.375 x .875 x .083
27	04001-32	Bolt, Hex Head 3/8-16 x 1-1/4" (Kawasaki)
	04030-04	Lockwasher, 3/8" Spring (Kawasaki)
	04001-11	Bolt, Hex Head 5/16-18 x 1-1/2" (Briggs)
	04019-03	Nut, 5/16-18 Serrated Flange
	04031-03	Lockwasher, 5/16" Spring (Briggs)
	04011-07	Capscrew, Hex Head 3/8-16 x 1-1/4" Self Tap (Briggs)

Ref. No.	Part No.	Description
28	483278	Solenoid
29	04011-14	Bolt, Self Tapping 1/2-20 x 3/4" Shakeproof
30	485419	Tank, LH - SFZ Pro
31	483434	Throttle Cable
32	462036	Instrument Panel w/Decal
33	483435	Choke Cable
34	483472	Ignition Switch
35	483366	Key, Ignition
	483609	Key w/Shroud
	462069	Key Assembly w/Fob
36	483957	PTO Switch
37	04001-08	Bolt, Hex Head 5/16-18 x 3/4"
38	04030-03	Lockwasher, 5/16" Spring

** Available through individual engine manufacturer.

SFZP FUEL SYSTEM

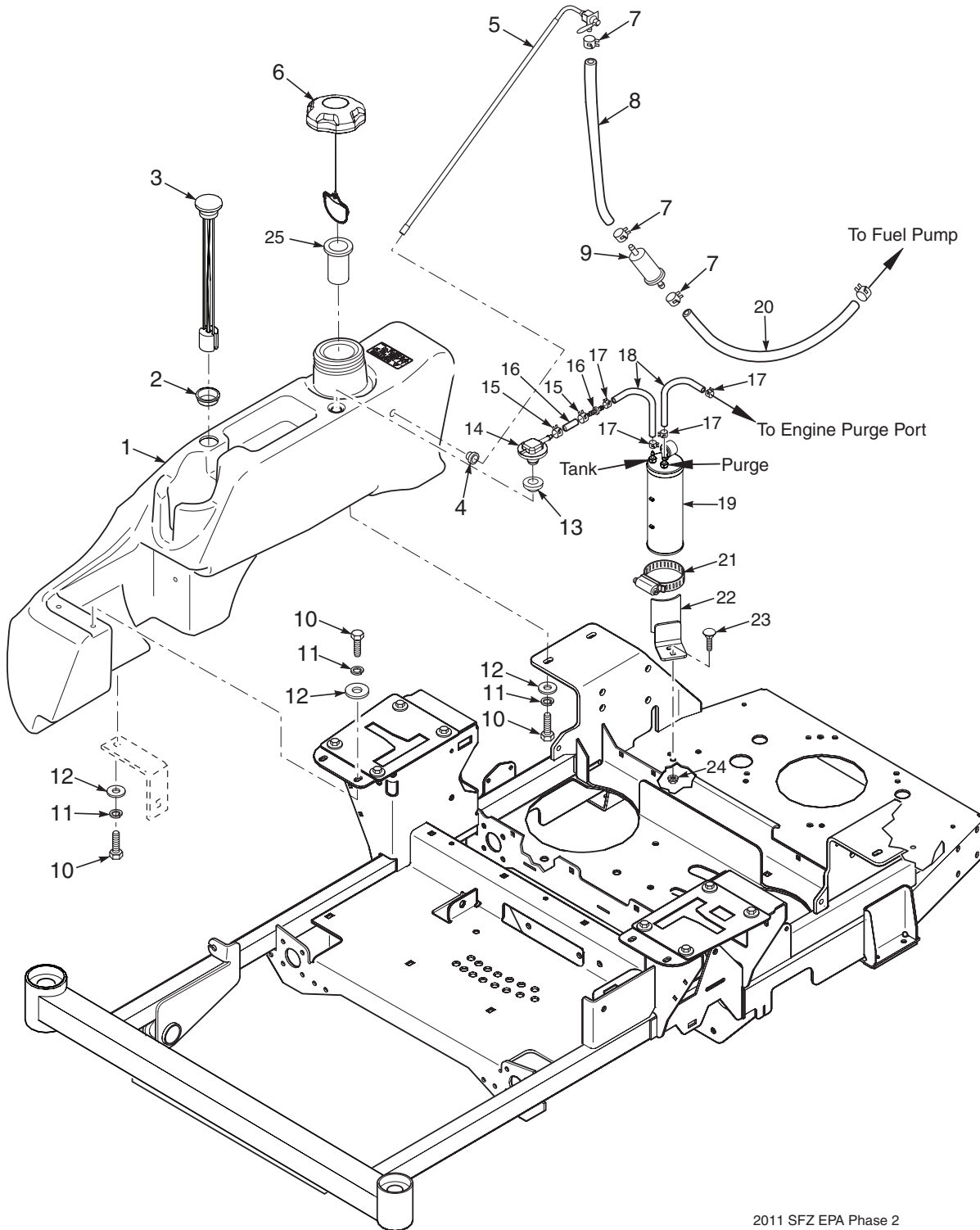

2011 SFZ EPA Phase 2

SFZP FUEL SYSTEM

Ref. No.	Part No.	Description
1	462755	Fuel Tank Assembly - SFZ Pro
2	484242	Grommet, Fuel Gauge
3	484243	Fuel Gauge Assembly
4	482571	Bushing, .56 Dia. Viton
5	483555	Fuel Tube Assembly
6	484286	Fuel Cap, Tethered
	484297	Fuel Cap w/Tethered - California Models Only (not shown)
7	48059-01	Clamp, Fuel Hose 1/4"
8	483617	Fuel Hose, 1/4" Non-Perm (order by inch)
9	*	Fuel Filter
10	04001-08	Bolt, Hex Head 5/16-18 x 3/4"
11	04030-03	Lockwasher, 5/16" Spring
12	04040-15	Flatwasher, 5/16-.375 x .875 x .083
13	484285	Grommet, Viton
14	484333	Remote Vent
15	48059-02	Clamp, Fuel Hose 7/32"
16	484347	Hose, 1/4" Vapor Recovery (order by inch)
17	48059-05	Clamp, Vapor Recovery Hose
18	484345	Hose, 3/16" (order by inch)
19	484342	Carbon Canister
20	*	Fuel Hose
21	48136-17	Clamp, Hose
22	452226	Bracket Weldment, SFZP52
	452233	Bracket Weldment, SFZP61
23	04003-12	Bolt, Carriage 5/16-18 x 3/4"
24	04019-03	Nut, Serrated Flange 5/16-18
25	484279-01	Tube, Fuel Tank Insert
26	484343-01	Mender, 1/4 x 3/16 w/0.02 Hole

* = Available through engine manufacturer only.

ZT-3100 HYDRAULIC AXLE ASSEMBLY - SFZP52

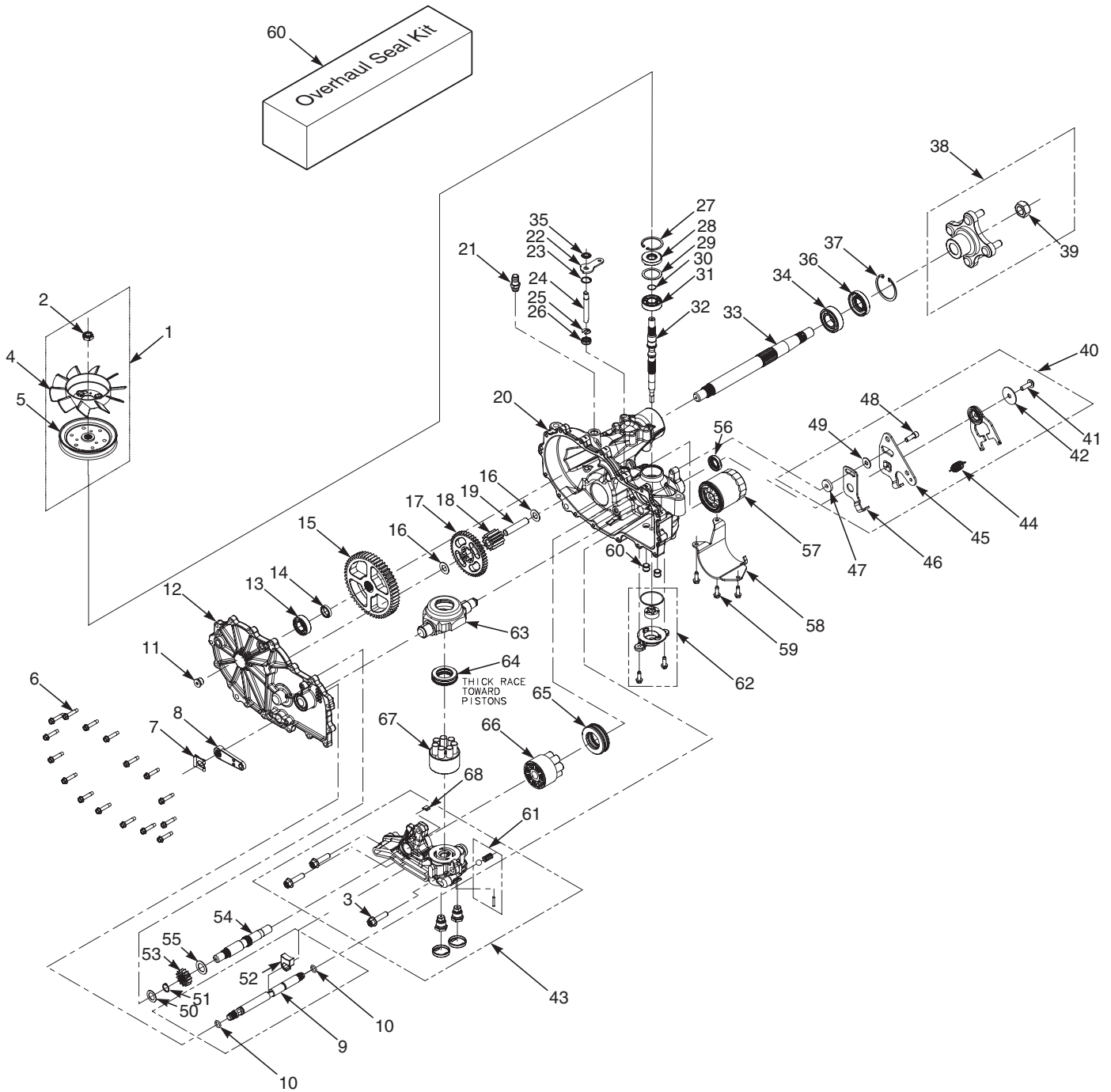

ZT-3100 HYDRAULIC AXLE ASSEMBLY - SFZP52

Ref. No.	Part No.	Description
1	HG72125	Kit, Fan & Pulley
2	HG51244	Nut, Hex Locking 1/2-20
3	HG52137	Bolt, Hex Head 3/8-16 x 1-1/2" Patch
4	HG53823	Fan, 7" Dai. (10 Blade)
5	HG52364	Pulley, Cupped 4-1/2" Dia
	HG52366	Hub, Pulley
6	HG51190	Bolt, Hex Head 1/4-20 x 1-11/4"
7	HG52027	Clip, Retaining
8	HG52639	Handle, Brake
9	HG52640	Shaft, Brake
10	HG51804	O-Ring
11	HG9005110-5600	Plug, 9/16-18
12	HG71572	Kit, Side Cover RH
	HG71574	Kit, Side Cover LH
13	HG44121	Bearing, Ball .75 x 40 x 12
14	HG52161	Spacer, .75 x 1.0 x .257
15	HG52108	Gear, 54T
16	HG50132	Washer, .5 x 1.0 x .03
17	HG52110	Gear, 45T
18	HG52586	Gear, 11T
19	HG51083	Jackshaft Pin
20	HG71413	Kit, Housing RH
	HG71421	Kit, Housing LH
21	482800-03	Fitting
22	HG51329	Arm, By-Pass
23	HG51627	Ring, Retaining .750 Internal
24	HG52136	Rod, By-Pass
25	HG51628	Ring, Retaining .375 External
26	HG51626	Seal, Lip .375 x .75 x .25
27	HG50329	Ring, Retaining 2.06 Internal
28	HG51161	Seal, Lip 17 x 40 x 7
29	HG50951	Washer, 1.23 x 1.56 x .04
30	HG2000022	Ring, Retaining Wire
31	HG50315	Bearing, Ball 17 x 40 x 12 Open
32	HG52155	Shaft, Input
33	HG71569	Shaft Kit, Axle
34	HG50771	Bearing, Ball 1.0 x 52 x 15 Open
35	HG51630	Ring, Retaining .375 External

Ref. No.	Part No.	Description
36	HG50772	Seal, Lip 25 x 52 x 10 TC Gray
37	HG50859	Ring, Retaining 2.06 Internal
38	HG71505	Hub Kit
39	HG50863	Nut, Hex Locking
40	HG71595	Kit, RTN Assembly (Does not include #44, 46, 47, 48, 49)
41	HG51812	Bolt, 5/16-24 x 1" Patch
42	HG51950	Washer, .343 x 1.5 x .062
43	HG71565	Kit, Center Section RH
	HG71566	Kit, Center Section LH
44	HG51605	Spring
45	HG52682	Arm, Control
46	HG51945	Arm, Neutral RH
	HG51946	Arm, Neutral LH
47	HG52527	Spacer, .320 x 1.005 x .179
48	HG51616	Bolt, 5/16-24 x 1" Patch
49	HG44130	Washer, .34 x .88 x .06
50	HG44371	Washer, .63 x 1.0 x .05
51	HG44145	Ring, Retaining
52	HG52641	Pawl, Brake
53	HG52341	Gear, 14T
54	HG52150	Shaft, Motor
55	HG51069	Washer, .72 x 1.16 x .04
56	HG51140	Seal, Lip 18 x 32 x 7
57	HG52114	Filter
58	HG52257	Filter Guard
59	HG50752	Bolt, 1/4-20 x 3/4"
60	HG71410	Seal Kit
61	HG71436	Kit, Charge Relief
62	HG71411	Kit, Charge Pump
63	HG51048	Trunnion Swashplate
64	HG50551	Thrust Bearing
65	HG51462	Thrust Bearing
66	HG71579	Kit, Motor Cylinder Block
67	HG70723	Kit, Cylinder Block
68	HG71448	Plate, By-Pass
69	HG71436	Kit, Charge Relief

ZT-3400 HYDRAULIC AXLE ASSEMBLY - SFZP61

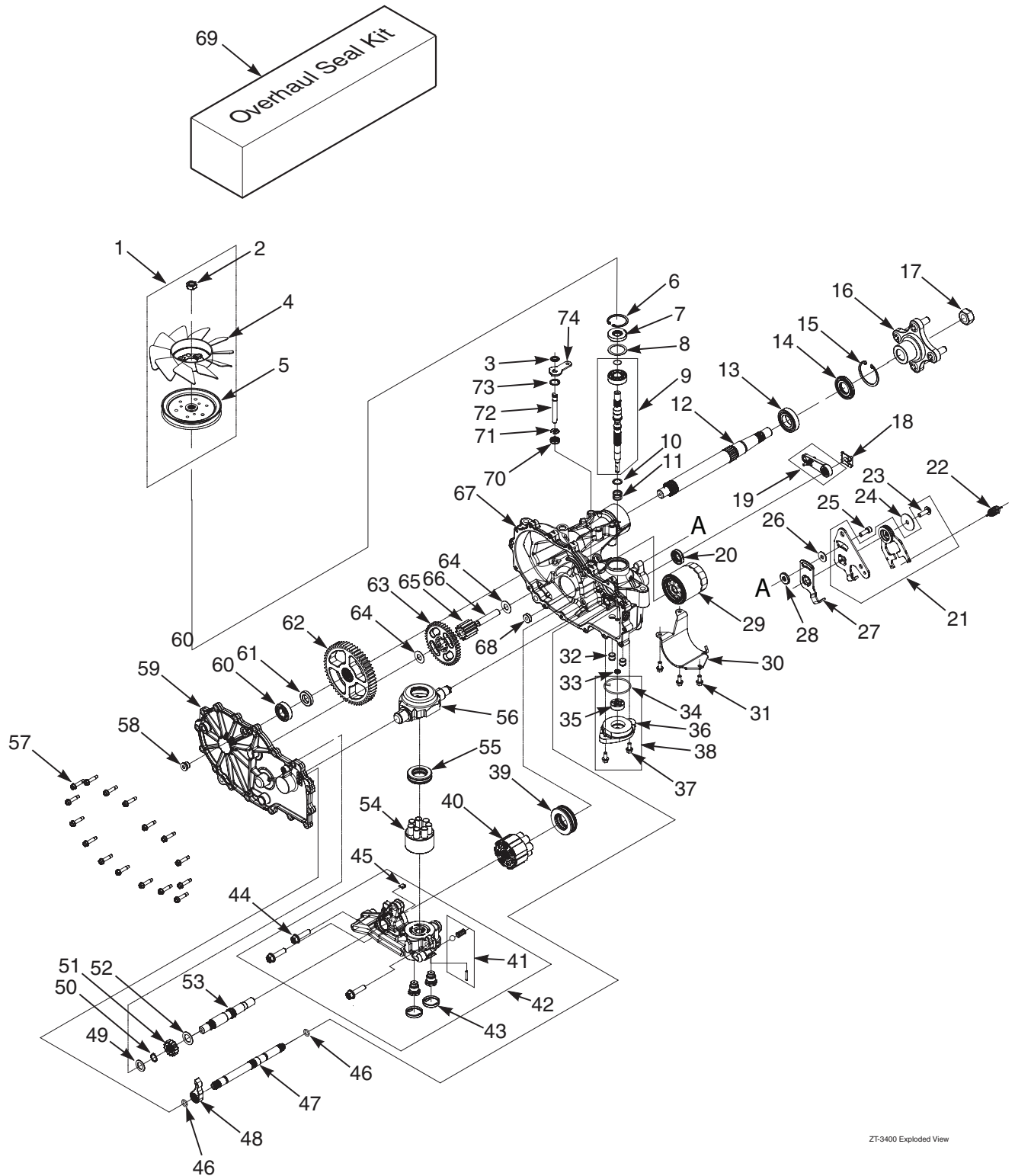

ZT-3400 HYDRAULIC AXLE ASSEMBLY - SFZP61

Ref. No.	Part No.	Description
1	HG71907	Kit, Fan & Pulley
2	HG44133	Nut, Elastic Stop 1/2-20
3	HG51523	Washer, OD Slotted .53 x 1.63 x .06
4	HG52747	Fan, 7" (10 Blade)
5	HG53435	Pulley"
6	HG53029	Ring, Retaining
7	HG51161	Seal, Lip 17 x 40 x 7
8	HG50951	Washer, 1.23 x 1.56 x .04
9	HG71978	Kit, Input Shaft
10	HG2003017	Washer, Flat .59 x .79 x .04
11	HG2003014	Spring, Block
12	HG53528	Shaft, Axle
13	HG50771	Bearing, Ball 25.4 x 52 x 15
14	HG50772	Seal, Lip 1 x 2.049 x .375
15	HG50859	Ring, Retaining 2.06 Internal
16	HG71405	Hub, 4-Bolt
17	HG50863	Nut, Hex Lock 3/4-16
18	HG52027	Clip, Retaining
19	HG52639	Handle, Brake Actuating
20	HG51140	Seal, Lip 12 x 32 x 7
21	HG71595	Kit, RTN Bi-Directional (Left Side)
	HG71598	Kit, RTN Bi-Directional (Right Side)
22	HG51605	Spring, RTN
23	HG51812	Bolt, Hex Head Cap Screw 5/16-24 x 1" Patch
24	HG51950	Washer, .343 x 1.5 x .062
25	HG51616	Bolt, Hex Head Cap Screw 5/16-24 x 1" Patch
26	HG44130	Washer, .34 x .88 x .06
27	HG51945	Arm, Neutral (Right Side)
	HG51946	Arm, Neutral (Left Side)
28	HG52527	Spacer, .320 x 1.005 x .179
29	HG52114	Filter, Oil
30	HG52257	Guard, Filter (Right Side)
	HG52247	Guard, Filter (Left Side)
31	HG53464	Screw, Hex Flange 1/4-20 x .625
32	HG52157	Tube, Connecting
33	HG53456	Seal, Lip 8 x 12 x 3-VC
34	HG52250	O-Ring, -.137 x .103 x 2.050
35	HG50273	Gerotor Assembly (1.9 cc)
36	HG53468	Cover, Charge Pump
37	HG53464	Screw, Hex Flange 1/4-20 x .625
38	HG71977	Kit, Charge Pump
39	HG51462	Bearing, Thrust

Ref. No.	Part No.	Description
40	HG71579	Assembly, Cylinger Block
41	HG71436	Kit, Charge Relief
42	HG71972	Kit, Center Section (Right Side)
	HG71973	Kit, Center Section (Left Side)
43	HG52162	Seal, Plug 1.250 x .250
44	HG52137	HFHCS, 3/8-16 X 1-1/2" Patch
45	HG51448	Plate, By-Pass
46	HG51804	O-Ring, -.111 x .103 x .424
47	HG42640	Shaft, Brake
48	HG52776	Pawl, Brake
49	HG44371	Washer, .63 x 1 x .05
50	HG44145	Ring, Retaining .625
51	HG52342	Gear, 13T Steel
52	HG51069	Washer, .72 x 1.16 x .04
53	HG52150	Shaft, Motor
54	HG71971	Assembly, Block 7 Piston
55	HG53502	Bearing, Thrust
56	HG51048	Trunnion, Swashplate
57	HG53246	HFHCS, 1/4-20 x 1-1/8"
58	HG9005110	Plug, 9/16-18
	-5600	
59	HG71990	Kit, Cover (Right Side)
	HG71992	Kit, Cover (Left Side)
60	HG44121	Bearing, Ball .75 x 40 x 12
61	HG53336	Spacer, .750 x 1.320 x .257
62	HG43327	Gear, 54T
63	HG52110	Gear, 45T
64	HG50132	Washer, .5 X 1 X .03
65	HG52341	Gear, 14T Steel
66	HG51083	Jackshaft Pin
67	HG72025	Kit, Housing Main (Right Side)
	HG72026	Kit, Housing Main (Left Side)
68	HG51100	Magnet, Ring
69	HG71976	Seal Kit
70	HG51626	Seal, Lip .375 x .75 x .25
71	HG51628	Ring, Retaining .375 External
72	HG52136	Rod, By-Pass
73	HG51677	Ring, Retaining .750 Internal
74	HG51629	Arm, By-Pass
75	HG51630	Ring, Retaining .375 External

REPLACEMENT DECALS AND INFORMATION PLATES

WARNING

 **INSTALL BELT COVER BEFORE OPERATING MACHINE**
READ OPERATOR'S MANUAL 483402

WARNING

DO NOT OPERATE WITHOUT DISCHARGE CHUTE, MULCHING KIT, OR ENTIRE GRASS CATCHER INSTALLED 483405

IMPORTANT

Operation on slopes can be hazardous. This machine was originally equipped with a Rollover Protection Device with a Roll Bar and Seat Belt. See your dealer if either is missing or damaged. 483425

DANGER

 **SPINNING BLADES**
KEEP CLEAR
BLADE CONTACT & THROWN OBJECTS CAN INJURE

FORWARD **R** **REVERSE**

 **F** 

WARNING

ROTATING BLADES AND BELTS

- * Keep hands, feet & clothing clear
- * Keep all guards in place
- * Shut off engine & disengage blade clutch before servicing
- * Use caution in directing discharge
- * Read instruction manual before operating

DO NOT OPERATE UNLESS GRASS CATCHER, MULCHING KIT OR DISCHARGE CHUTE IS INSTALLED 483406

WARNING

Replace seat only with Scag approved seat with seat mounting provisions and Scag approved seat belts. Failure to follow these directions could result in injury or death in the event of a rollover. 483407

61
COMMERCIAL GRADE

IMPORTANT ADJUSTMENT PROCEDURES
READ OPERATORS MANUAL FOR MORE DETAILS

Check tire pressure - Drive tires-8 psi -
- Caster tires-25 psi

FREE WHEEL OPERATION
To move machine without running engine, pull both dump valve rods up and back (located at rear of machine) and latch. Pull rods forward and latch into front slot to operate mower.

NEUTRAL ADJUSTMENT

Adjusting Nut
Jamnut

To re-set neutral, loosen jamnut. With operator in seat, control levers in neutral and brake off, turn adjusting bolt until wheel doesn't creep. Tighten jam nut. Repeat for opposite side. If wheels still creep after adjustment, see an authorized Scag dealer.

HYDRAULIC FLUID LEVEL
Check hydraulic fluid level while fluid is cool. Fluid level should be in sight window. Fill with 20W50 motor oil only.

IMPORTANT
Do not overfill. Room for hot fluid expansion must be allowed or resulting expansion may cause leaks in the system

TRACKING ADJUSTMENT

Control Lever
Stop Bolt

If machine pulls to right, adjust LH control stop bolt CW (Inward) to slow left wheel down.
If machine pulls to left, adjust RH control stop bolt CW (Inward) to slow right wheel down.



483660



PARKING BRAKE

TO ENGAGE PARKING BRAKE:
*Fully depress foot pedal
*Pull back and hold latch handle while releasing pedal

TO DISENGAGE PARKING BRAKE:
*Depress and release pedal

484461

REPLACEMENT DECALS AND INFORMATION PLATES

Ref. No.	Part No.	Description
1	483402	Decal, Belt Cover
2	483405	Decal, Warning
3	483425	Decal, ROPS
4	483505	Decal, Spinning Blades
5	481568	Decal, Traction Control
6	483633	Decal, Seat Replacement
7	483495	Decal, 52 Commercial
	484044	Decal, 61 Commercial
8	483406	Decal, Knives
9	483660	Decal, Adjustment SFZ
10	483499	Decal, Instrument Panel
11	485423	Decal, Front SFZ Pro
12	485413	Decal, Cutting Height - SFZ Pro
13	484461	Decal, Brake
14	485365	Decal, SFZ Replacement Parts
*	483900	Decal, Warning Spark Arrestor (California only) - not shown
*	462155	Spanish Decal Kit - SFZ (not shown)
*	01411	DVD Video, Tips for Safe Operation of Your Scag Zero-Turn Mower (not shown)

SCAG FREEDOM Z PRO

11

START/DRIVE PROCEDURE

- Engage parking brake
- Disengage mower deck drive
- Move control handles to neutral position
- Start Engine
- Select forward or reverse with hydro control levers

RELEASE DECK LATCH

FREEDOM Z PRO

WARNING

AVOID SERIOUS INJURY OR DEATH. Read the Operator's Manual. Reducible quantities on approval or an distributor Scag. Operate only on slopes you can backup. All mowing steps go down slowly. Stop blades and deck down slowly. Avoid sudden turns. Do not mow when children or others are around. Never carry children even with blades off. Attach deck and blades before and while docking. Keep safety devices (guards, shields, sensors, etc.) in place and working. Remove objects that could be struck by the blades. Stranded operators only.

12

Always use original Scag replacement parts for top machine performance and to maintain factory warranty.

SCAG POWER EQUIPMENT	Replacement Parts Numbers	FREEDOM Z
Belt, Transmission Drive (48" & 52")	483314	Standard Blade, Cutter (48") 482877
Belt, Transmission Drive (61")	484372	Standard Blade, Cutter (52") 482878
Belt, Cutter Deck (48")	483325	Standard Blade, Cutter (61") 482879
Belt, Cutter Deck (52")	483326	Filter, Hydraulic (25 micron) HG52114
Belt, Cutter Deck (61")	484031	

See your authorized Scag dealer for engine part numbers.

ph 486385

14

SFZP - ELECTRICAL SCHEMATIC

(shown with Key Off, PTO Off, Park Brake Applied, Control Handles in Neutral, Seat Switch Disengaged)

