

SCAG® POWER EQUIPMENT

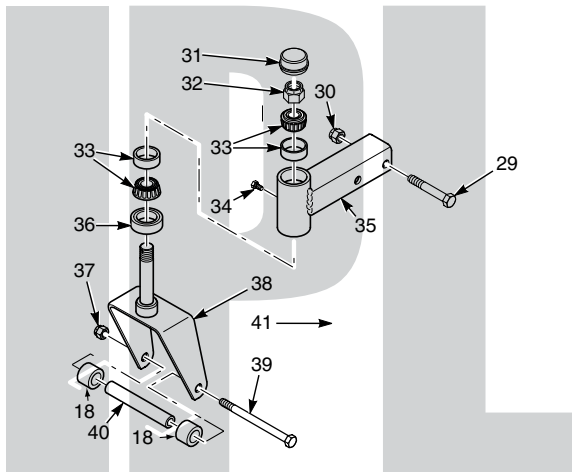

ILLUSTRATED PARTS MANUAL



Model STCII *TIGER CAT. II*

THIS MANUAL CONTAINS THE ILLUSTRATED PARTS LIST FOR MODELS:

**STCII-48V-22FS
STCII-48V-23CV
STCII-52V-22FX
STCII-52V-25CV-EFI
STCII-61V-23FX
STCII-61V-26CV-EFI**

**with a serial number of L8800001 to L8899999
with a serial number of L8900001 to L8999999
with a serial number of L9000001 to L9099999
with a serial number of L9100001 to L9199999
with a serial number of L9200001 to L9299999
with a serial number of L9300001 to L9399999**

Table of Contents

48V & 52V CUTTER DECKS	2
61V CUTTER DECK	4
CUTTER DECK CONTROLS	6
SHEET METAL COMPONENTS	8
STCII FOLDABLE ROLL-OVER PROTECTION SYSTEM	10
STCII SUSPENSION SEAT	12
STCII SOFT RIDE SEAT W/BLACK ARMRESTS	13
DRIVE SYSTEM COMPONENTS	14
ENGINE & ATTACHING PARTS.....	16
STEERING COMPONENTS.....	18
BRAKE COMPONENTS	20
HYDRAULIC SYSTEM	22
STCII FUEL SYSTEM.....	24
ELECTRICAL SYSTEM	26
ELECTRICAL SYSTEM - KOHLER EFI.....	28
STCII HYDRAULIC PUMP ASSEMBLY	30
REPLACEMENT DECALS AND INFORMATION PLATES	32
STCII ELECTRICAL SCHEMATIC	34
STCII-EFI ELECTRICAL SCHEMATIC	35
STCII KAWASAKI ENGINE ADAPTER ELECTRICAL SCHEMATIC.....	36
STCII KOHLER ENGINE ADAPTER ELECTRICAL SCHEMATIC	37

48V & 52V CUTTER DECKS

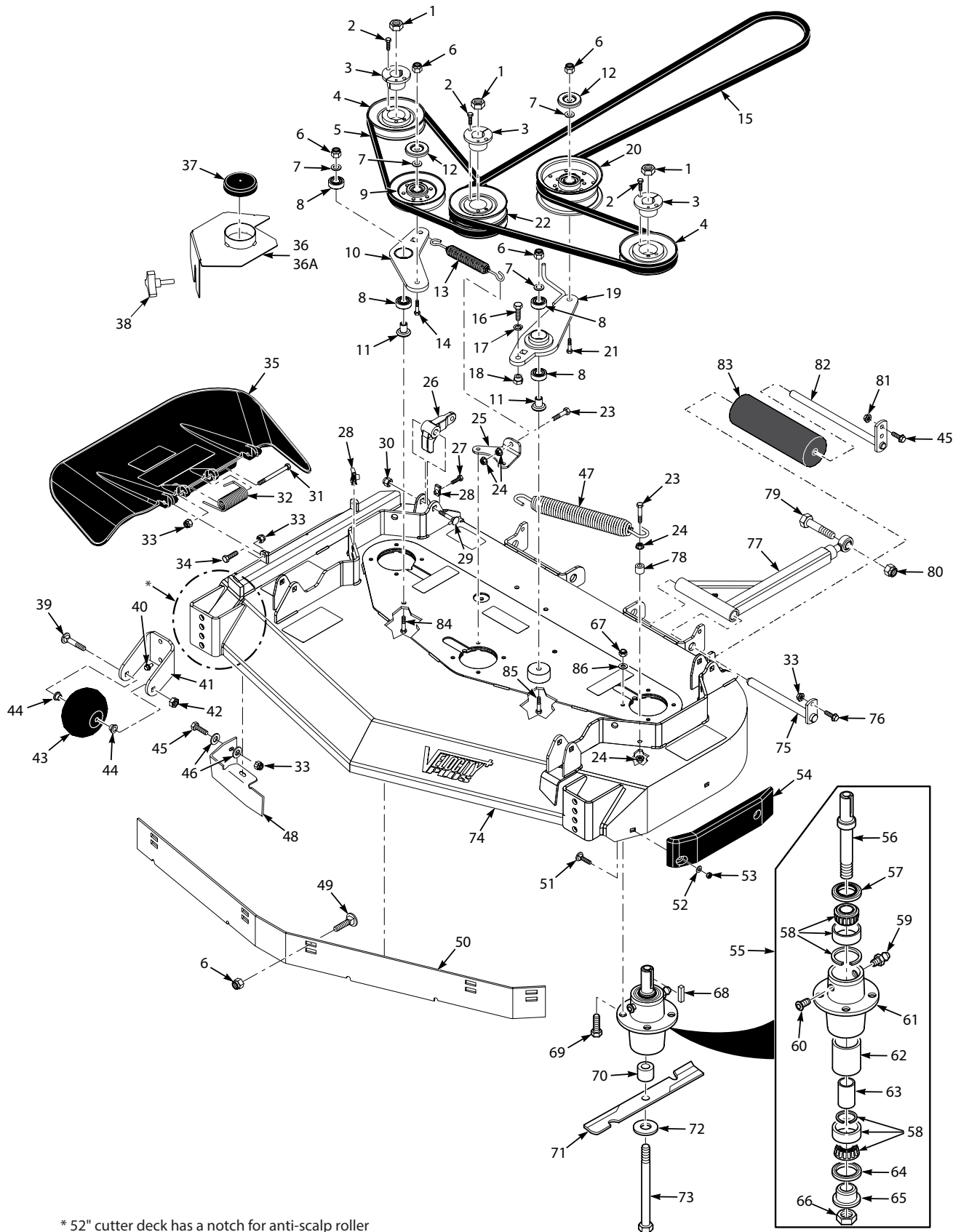

Section 8

48V & 52V CUTTER DECKS

Ref. No.	Part No.	Description	48	52	Ref. No.	Part No.	Description	48	52
1	04020-09	Nut, 5/8-11 UNC	X	X	42	04021-05	Locknut, 3/8-16 Center Lock	X	X
2	04001-172	Bolt, Hex Head 1/4-20 x 1" Grade 8	X	X	43	481632	Anti-Scalp Wheel	X	X
3	48926	Hub, Tapered 1-1/8" Bore	X	X	44	48100-15	Bushing, .376 ID Oilite	X	X
4	483282	Pulley 4.75"	X		45	04001-09	Bolt, Hex Head 5/16-18 x 1"	X	X
	483284	Pulley 5.35"		X	46	04040-15	Flatwasher, 5/16"	X	X
5	483239	Belt, RH Cutter Deck	X		47	483246	Spring, Idler LH	X	X
	483240	Belt, RH Cutter Deck		X	48	424677	Turbo Baffle, Bolt On	X	X
6	04021-09	Nut, Elastic Stop 3/8-16	X	X		*425619	Turbo Baffle, 48V	X	
7	04043-04	Flatwasher, 3/8"	X	X		*424211	Turbo Baffle, 52V		X
8	48224	Bearing	X	X	49	04003-23	Bolt, Carriage 3/8-16 x 1"	X	X
9	48181	Pulley, Idler 5" Dia.	X	X	50	424839	Baffle Custom-Cut, 48V (7-Position)	X	
10	461946	Idler Arm (Incl. #8)	X	X		424840	Baffle Custom-Cut, 52V (7-Position)		X
11	43689	Idler Pivot	X	X	51	04003-12	Bolt, Carriage 5/16-18 x 3/4"	X	X
12	424367	Dust Shield	X	X	52	04040-04	Flatwasher, 5/16"	X	X
13	483247	Spring, Idler RH	X	X	53	04021-04	Nut, Center Lock 5/16-18	X	X
14	04001-45	Bolt, Hex Head 3/8-16 x 2"	X	X	54	483176	Wear Pad	X	X
15	485634	Belt, Cutter Deck Drive (48V)	X		55	461663	Spindle Assembly	X	X
	485635	Belt, Cutter Deck Drive (52V)		X	56	43589	Shaft, Spindle	X	X
16	04001-27	Bolt, Hex Head 7/16-14 x 1"	X	X	57	481024	Seal Upper	X	X
17	04030-05	Lockwasher 7/16"	X	X	58	481022	Bearing Assembly	X	X
18	43686	Boss, Spring Anchor	X	X	59	48114-04	Grease Fitting	X	X
19	462503	Idler Arm (Includes 8)	X	X	60	48677	Valve, Grease Relief	X	X
20	483210	Pulley, Idler 5" Dia.	X	X	61	43644	Housing, Spindle	X	X
21	04001-54	Bolt, Hex Head 3/8-16 x 3"	X	X	62	43312	Spacer, Outside	X	X
22	483283	Pulley, Double Groove	X		63	43296	Spacer, Inside	X	X
	483285	Pulley, Double Groove		X	64	481025	Seal, Lower	X	X
23	04001-136	Bolt, Hex Head 3/8-16 x 1-1/2" Gr. 8	X	X	65	43297	Bushing, Bottom	X	X
24	04019-04	Nut, 3/8-16 Serrated Flange	X	X	66	481035	Nut, Special 1-1/16 - 18	X	X
25	424376	Bracket, Spring Anchor RH (48V)	X		67	04021-22	Nut, Elastic Stop 5/16-18 Grade 8	X	X
	424377	Bracket, Spring Anchor RH (52V)		X	68	04063-08	Key, 1/4 x 1/4 x 2"	X	X
26	485528	Lever, Deck Level	X	X	69	04001-176	Bolt, Hex Head 5/16-18 x 1-3/4" Gr. 8	X	X
27	04107-04	Bolt, Hex Head 3/8-16 x 2" Spec	X	X	70	43590	Spacer, Spindle	X	X
28	04110-03	U-Nut, 3/8-16	X	X	71	482877	Cutter Blade 16.5"	X	
29	04003-42	Bolt, Carriage 7/16-14 x 2-1/4"	X	X		482878	Cutter Blade 18"		X
30	04021-11	Nut, Elastic Stop 7/16-14	X	X	72	04043-06	Flatwasher, 5/8" Hardened	X	X
31	04001-154	Bolt, Hex Head 5/16-18 x 4-3/4"	X	X	73	04001-41	Bolt, Hex Head 5/8-11 x 9-1/2"	X	X
32	483378	Spring, Discharge Chute	X	X	74	462867	Cutter Deck Velocity Plus	X	
33	04021-10	Nut, Elastic Stop 5/16-18	X	X		462868	Cutter Deck Velocity Plus		X
34	04001-12	Bolt, Hex Head 5/16-18 x 1-3/4"	X	X	75	451240	Push Arm Shaft	X	X
35	461844	Discharge Chute Assy.	X		76	04001-09	Bolt, Hex Head 5/16-18 x 1"	X	X
	*462473	CA Discharge Chute, 48V	X		77	461443	Push Arm Assembly LH	X	X
	461845	Discharge Chute Assy.		X		461444	Push Arm Assembly RH	X	X
	462475	CA Discharge Chute, 52V		X	78	43063	Spacer	X	X
36	462480	Belt Cover Weldment RH (incl. #37)	X		79	04001-79	Bolt, Hex Head 5/8-11 x 4-1/2"	X	X
	462822	Belt Cover Weldment LH (incl. #37)	X		80	04021-13	Nut, Elastic Stop 5/8-11	X	X
36A	462825	Belt Cover Weldment RH (incl. #37)		X	81	04117-01	Locknut, 5/16-18 Flange Hex Head	X	X
	462824	Belt Cover Weldment LH (incl. #37)		X	82	45944	Shaft, Roller	X	X
37	484368	Cap, Spindle	X	X	83	48038	Roller, Rear	X	X
38	481625-01	Wing Nut, 3/8-16	X	X	84	04001-46	Bolt, Hex Head 3/8-16 x 2-1/4"	X	X
39	04003-26	Bolt, Carriage 3/8-16 x 4"	X	X	85	04001-62	Bolt, Hex Head 3/8-16 x 3-1/4"	X	X
40	04017-27	Bolt, Serrated Flange 3/8-16 x 1"	X	X	86	04030-03	Lockwasher 5/16"	X	X
41	422478	Bracket, Anti-Scalp Wheel	X	X					

* = California Models Only (not shown)

61V CUTTER DECK

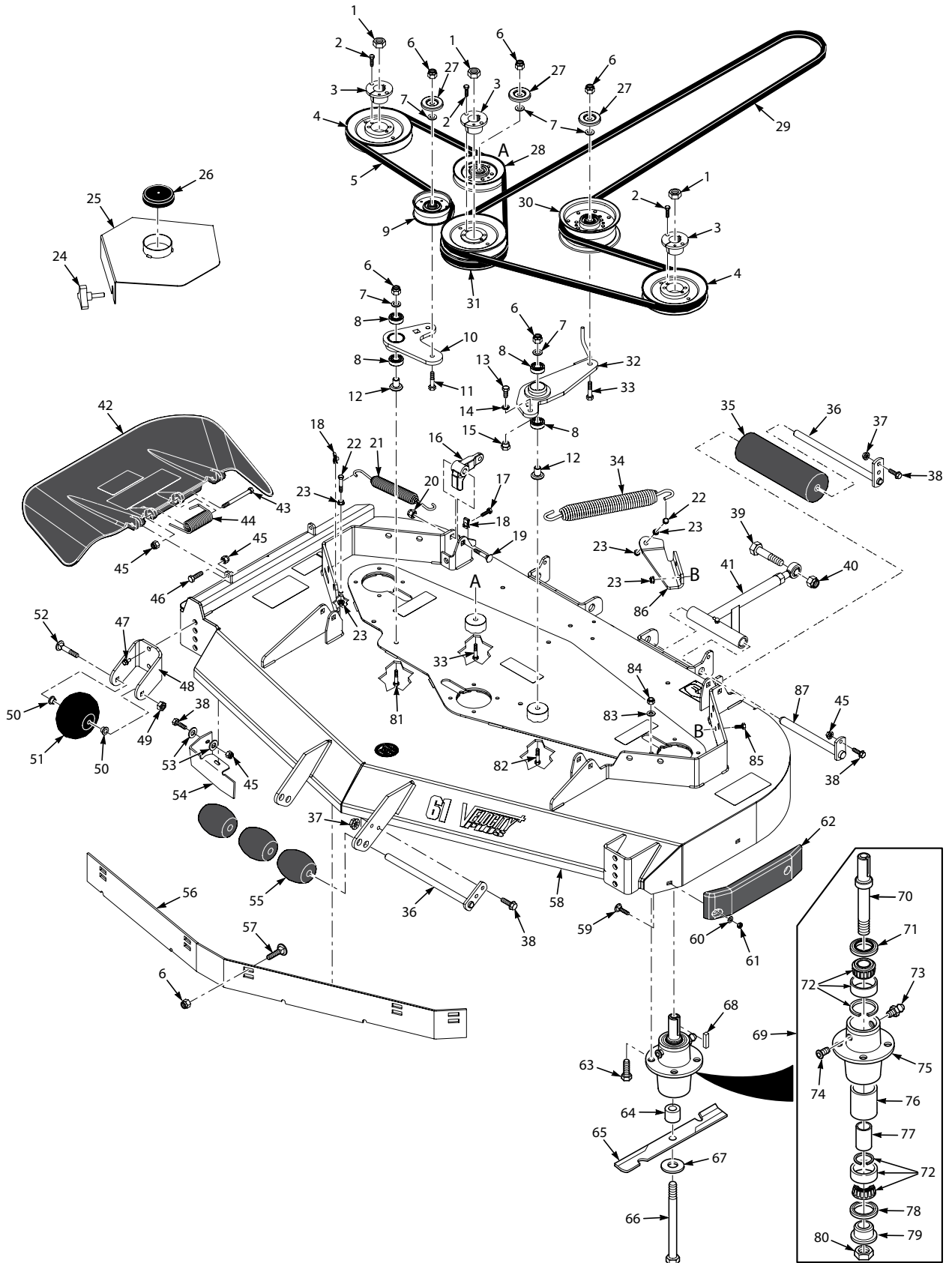

Section 8

61V CUTTER DECK

Ref. No.	Part No.	Description
1	04020-09	Nut, 5/8-11 UNC
2	04001-172	Bolt, Hex Head 1/4-20 x 1" Grade 8
3	48926	Hub, Tapered 1-1/8" Bore
4	483286	Pulley, Tapered Bore 6.33" Dia.
5	483157	Belt, Deck Drive RH
6	04021-09	Nut, Elastic Stop 3/8-16
7	04043-04	Flatwasher, 3/8" - .938 x .391 x .105"
8	48224	Bearing
9	483415	Idler Pulley, 3-1/2" Dia.
10	462888	Idler Arm (Incl. #8)
11	04001-31	Bolt, Hex Head 3/8-16 x 2-1/2"
12	43689	Pivot, Idler Arm
13	04001-27	Bolt, Hex Head 7/16-14 x 1"
14	04030-05	Lockwasher 7/16"
15	43686	Boss, Spring Anchor
16	485528	Lever, Deck Level
17	04107-04	Bolt, Hex Head 3/8-16 x 2" Spec
18	04110-03	U-Nut, 3/8-16
19	04003-42	Bolt, Carriage 7/16-14 x 2-1/4"
20	04021-11	Nut, Elastic Stop 7/16-14
21	483703	Spring, RH Deck Drive
22	04001-136	Bolt, Hex Head 3/8-16 x 1-1/2" Gr.8
23	04019-04	Nut, Serrated Flange 3/8-16
24	481625-01	Wing Nut, 3/8-16
25	462818	Belt Cover Weldment (incl. #26)
26	484368	Cap, Spindle
27	424367	Dust Shield
28	48181	Idler Pulley, 5" Dia.
29	485636	Belt, Deck Drive 61V
30	483210	Idler Pulley, 5" Dia.
31	483287	Pulley, Double Groove 6.33" Dia.
32	462269	Idler Arm (Incl. #8)
33	04001-54	Bolt, Hex Head 3/8-16 x 3"
34	483246	Spring, LH Deck Drive
35	48038	Roller, Rear
36	45944	Shaft, Roller
37	04117-01	Locknut, 5/16-18 Flange Hex Head
38	04001-09	Bolt, Hex Head 5/16-18 x 1"
39	04001-79	Bolt, Hex Head 5/8-11 x 4-1/2"
40	04021-13	Nut, Elastic Stop 5/8-11
41	461443	Push Arm Assembly LH
	461444	Push Arm Assembly RH
42	461846	Discharge Chute Assy.
	*462477	CA Discharge Chute Assy.
43	04001-154	Bolt, Hex Head 5/16-18 x 4-3/4"

Ref. No.	Part No.	Description
44	483378	Spring, Discharge Chute
45	04021-10	Nut, Elastic Stop 5/16-18
46	04001-12	Hex Head 5/16-18 x 1-3/4"
47	04017-27	Bolt, Serrated Flange 3/8-16 x 1"
48	424478	Bracket, Anti-Scalp Wheel
49	04021-05	Locknut, 3/8-16 Center Lock
50	48100-15	Bushing, .376 ID Oilite
51	481632	Anti-Scalp Wheel
52	04003-26	Bolt, Carriage 3/8-16 x 4"
53	04040-15	Flatwasher 5/16"
54	424209	Turbo Baffle, Bolt On
	*425625	Turbo Baffle 61V
55	482295	Wheel, Anti Scalp
56	424841	Baffle Custom-Cut, 61V (7-Position)
57	04003-23	Bolt, Carriage 3/8-16 x 1"
58	462869	Cutter Deck Velocity Plus
59	04003-12	Bolt, Carr. 5/16-18 x 3/4"
60	04040-04	Flatwasher, 5/16-.344 x .688 x .065"
61	04021-04	Nut, Center Lock 5/16"
62	483176	Wear Pad
63	04001-176	Bolt, Hex Head 5/16-18 x 1-3/4" Grade 8
64	43590	Spacer, Spindle
65	482879	Cutter Blade 21"
66	04001-41	Bolt, Hex Head 5/8-11 x 9-1/2"
67	04043-06	Flatwasher, 5/8" Hardened
68	04063-08	Key, 1/4 x 1/4 x 2"
69	461663	Spindle Assembly
70	43589	Shaft, Spindle
71	481024	Seal Upper
72	481022	Bearing Assembly
73	48114-04	Grease Fitting
74	48677	Valve, Grease Relief
75	43644	Housing, Spindle
76	43312	Spacer, Outside
77	43296	Spacer, Inside
78	481025	Seal, Lower
79	43297	Bushing, Bottom
80	481035	Nut, Special 1-1/16 - 18
81	04001-46	Bolt, Hex Head 3/8-16 x 2-1/4"
82	04001-62	Bolt, Hex Head 3/8-16 x 3-1/4"
83	04030-03	Lockwasher 5/16"
84	04021-22	Nut, Elastic Stop 5/16-18 Grade 8
85	04001-19	Bolt, Hex Head 3/8-16 x 1"
86	427023	Bracket, Spring Anchor
87	451240	Push Arm Shaft

* = California Models Only (not shown)

CUTTER DECK CONTROLS

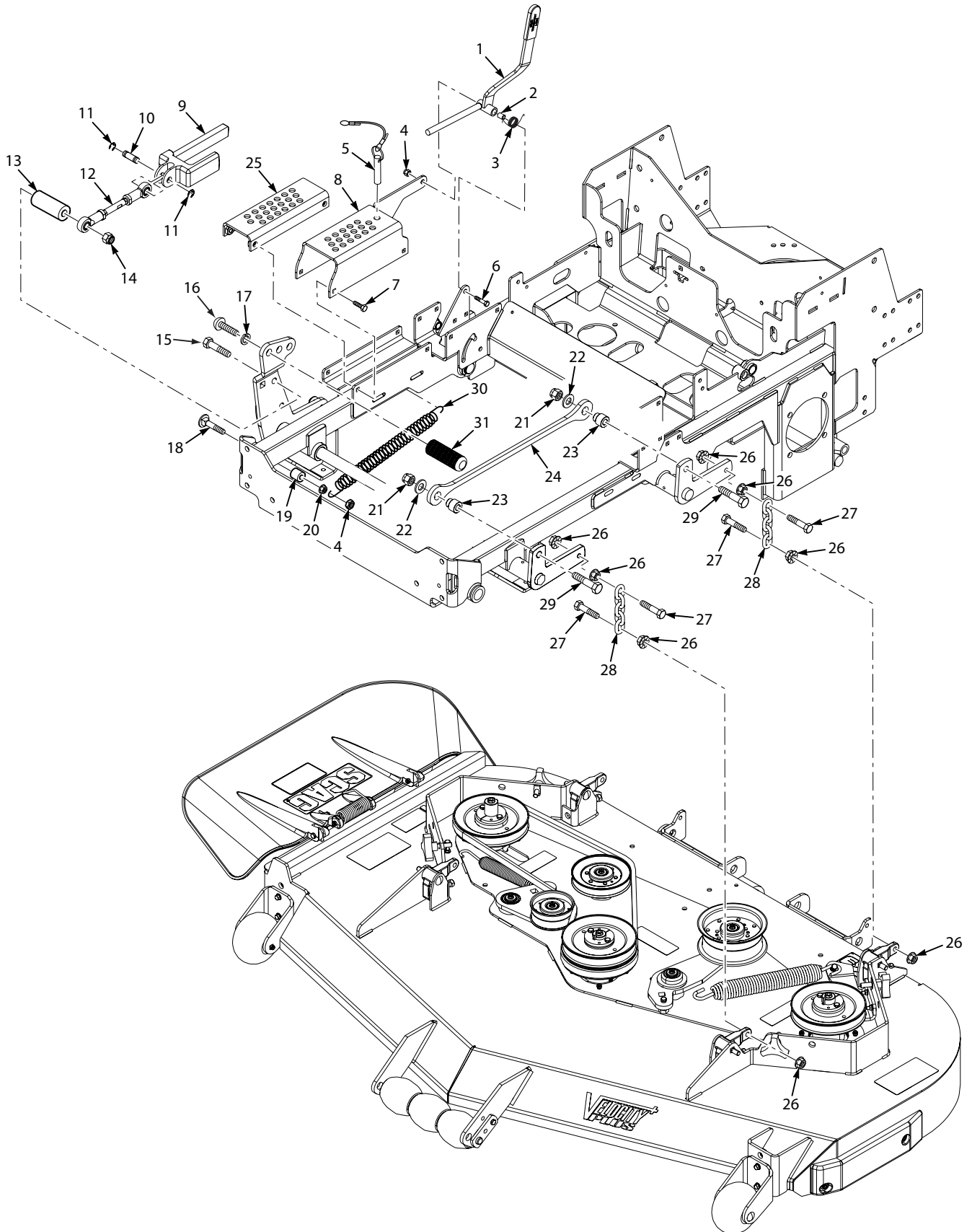

CUTTER DECK CONTROLS

Ref. No.	Part No.	Description
1	462839	Deck Latch Assembly (Includes Grip)
	485592	Grip, Deck Latch
2	43874	Spacer, Deck Latch
3	485704	Spring, Torsion - Lever Return
4	04021-05	Nut, Center Lock 3/8-16
5	483345	Pin Assembly, w/Lanyard
6	04001-31	Bolt, Hex Head 3/8-16 x 2-1/2"
7	04006-02	Bolt, Hex Wshr Head 5/16-18 x 1-1/4"
8	425737	Adjustment Bracket, Cutting Height
9	485570	Slide, Height Adjust
10	43487	Pin, Deck Lift
11	04050-18	Retaining Ring, 1/2" Ext.
12	482534	Linkage Assembly, Deck Lift
13	43873	Spacer, Deck Lift Pedal
14	04021-07	Nut, Elastic Stop 1/2-13
15	04001-87	Bolt, Hex Head 1/2-13 x 4"
16	04108-04	Capscrew, 5/8-11 x 1-1/2"
17	04030-07	Lockwasher, 5/8" Spring
18	04003-21	Bolt, Carriage 3/8-16 x 2-1/2"
19	43572	Spacer
20	040419-04	Nut, Serrated Flange 3/8-16
21	04021-07	Nut, Elastic Stop 1/2-13
22	04040-13	Flatwasher, 1/2-.562 x 1.375 x .109
23	431018	Pivot, Deck Link
24	427012	Link, Decklift
25	452408	Adjustment Bracket, Lower Cut Height
26	04019-04	Nut, Serrated Flange 3/8-16
27	04001-20	Bolt, Hex Head 3/8-16 x 1-1/2"
28	48540	Chain
29	04001-153	Bolt, Hex Head 1/2-13 x 2-1/4"
30	483177	Spring, Decklift
31	424504	Foot Pedal, Height Adjustment

SHEET METAL COMPONENTS

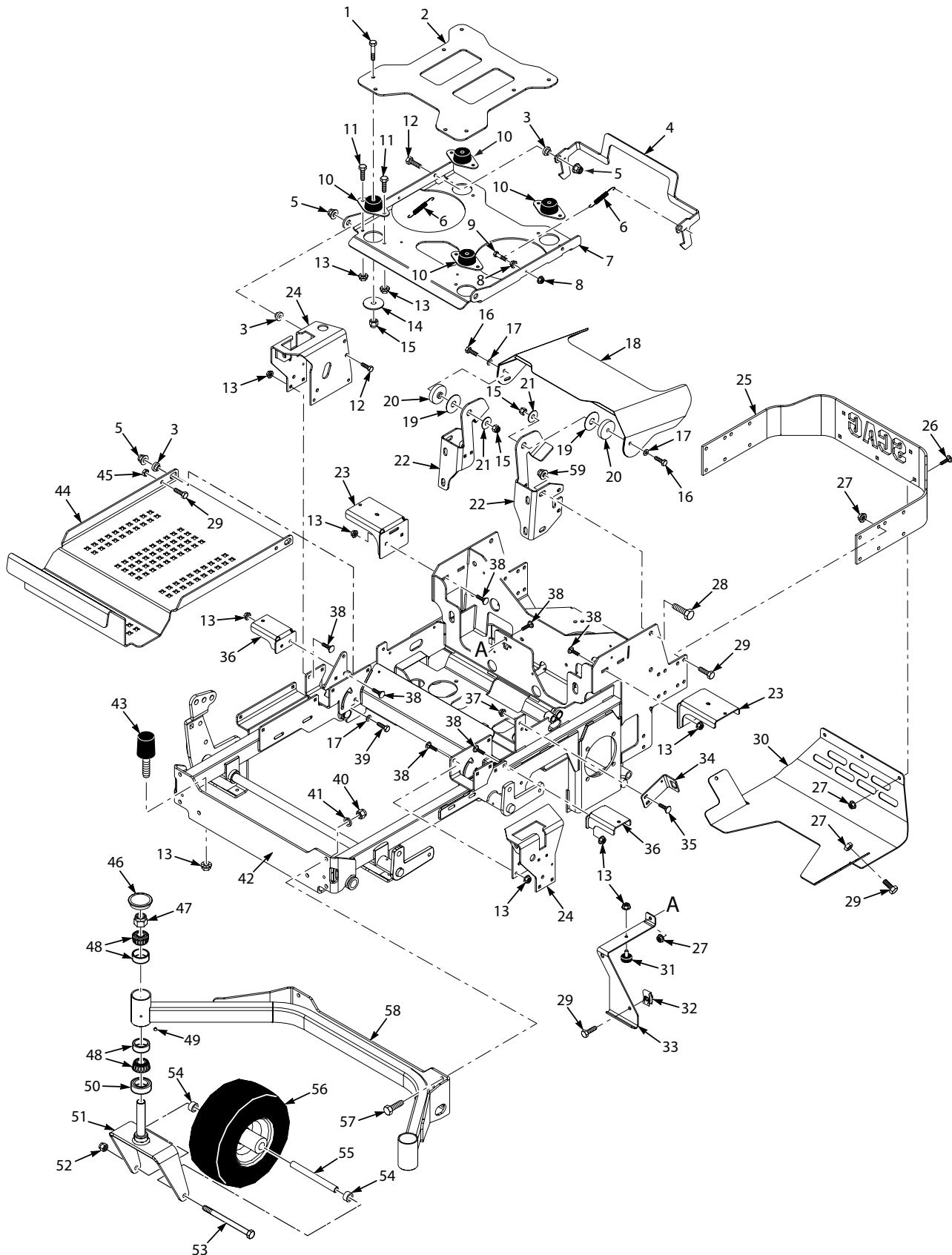

SHEET METAL COMPONENTS

Ref. No.	Part No.	Description
1	04001-46	Bolt, Hex Head 3/8-16 x 2-1/4"
2	462863	Seat Plate w/decal
3	43086	Bushing
4	426949	Seat Latch
5	04117-02	Nut, Elastic Flange 3/8-16
6	484498	Spring, Seat Latch
7	462864	Plate, Seat Mounting w/decals
8	04019-02	Nut, Serrated Flange 1/4-20
9	04001-59	Bolt, Hex Head 1/4-20 x 1-1/4"
10	484148	Isolator, Seat
11	04001-08	Bolt, Hex Head 5/16-18 x 3/4"
12	04001-32	Bolt, Hex Head 3/8-16 x 1-1/4"
13	04019-03	Nut, Hex Serr. Flng 5/16-18
14	04041-38	Flatwasher, 3/8-.406 x 2.25 x .1875
15	04021-09	Nut, Elastic Stop 3/8-16
16	04001-21	Bolt, Hex Head 3/8-16 x 1-3/4"
17	04041-07	Flatwasher, 3/8-.391 x .938 x .105
18	462838	Hood Assembly
19	483471	Disk, Anti-Friction
20	43740	Spacer, Hood
21	04041-11	Flatwasher, 3/8-.406 x 1.50 x 7 Ga.
22	427029	ROPS Mount, RH
	427028	ROPS Mount, LH
23	427063	Mounting Bracket, Fuel Tank Rear
24	462859	Control Plate w/decal, RH
	462858	Control Plate w/decal, LH
25	425725	Bumper, Rear
26	04003-23	Bolt, Carriage 3/8-16 x 1"
27	04019-04	Nut, 3/8-16 Serr. Flange
28	04001-70	Bolt, Hex Head 1/2-13 x 1-1/4"
29	04001-19	Bolt, Hex Head 3/8-16 x 1"
30	427032	Plate, Skid
31	481284	Bumper, Rubber
32	04110-03	U-Nut, 3/8-16

Ref. No.	Part No.	Description
33	426978	Battery Hold Down
34	425905	Mounting Bracket, Neutral Switch
35	04003-02	Bolt, Carriage 1/4-20 x 3/4"
36	425862	Mounting Bracket, Fuel Tank Front
37	04117-03	Nut, Flanged Elastic Stop 1/4-20
38	04003-12	Bolt, Carriage 5/16-18 x 3/4"
39	04001-20	Bolt, Hex Head 3/8-16 x 1-1/2"
40	04021-11	Nut, Elastic Stop 7/16-14
41	04030-05	Lockwasher, 7/16" Spring
42	462861	Main Frame Assembly w/decals (48"/52")
	462870	Main Frame Assembly w/decals (61")
43	485663	Rubber Isolator
44	426931	Footplate
45	04020-12	Nut, Jam 3/8-16
46	484195	Cap, Grease
47	04021-20	Nut, Elastic Stop 1.0"-14
48	481657	Bearing Set
49	482028-01	Plug, 1/4-28
50	481025	Seal, 2.0" OD x 1.625" ID
51	451471	Yoke, Front Caster Wheel (48"/52")
	451658	Yoke, Front Caster Wheel (61")
52	04021-07	Nut, Hex Elastic Stop 1/2-13
53	04001-134	Bolt, Hex Head 1/2-13 x 7-1/2" (48"/52")
	04001-167	Bolt, Hex Head 1/2-13 x 9-1/2" (61")
54	43584	Spacer, Caster Wheel
55	43581	Sleeve (48"/52")
	43583	Sleeve (61")
56	482503	Caster Wheel Assembly (48"/52")
	482504	Caster Wheel Assembly (61")
57	04001-28	Bolt, Hex Head 7/16-14 x 1-1/4"
58	452284	Caster Support Weldment (48"/52")
	452727	Caster Support Weldment (61")
59	04117-04	Nut, 1/2-13 Flange Elastic Stop

STCII FOLDABLE ROLL-OVER PROTECTION SYSTEM

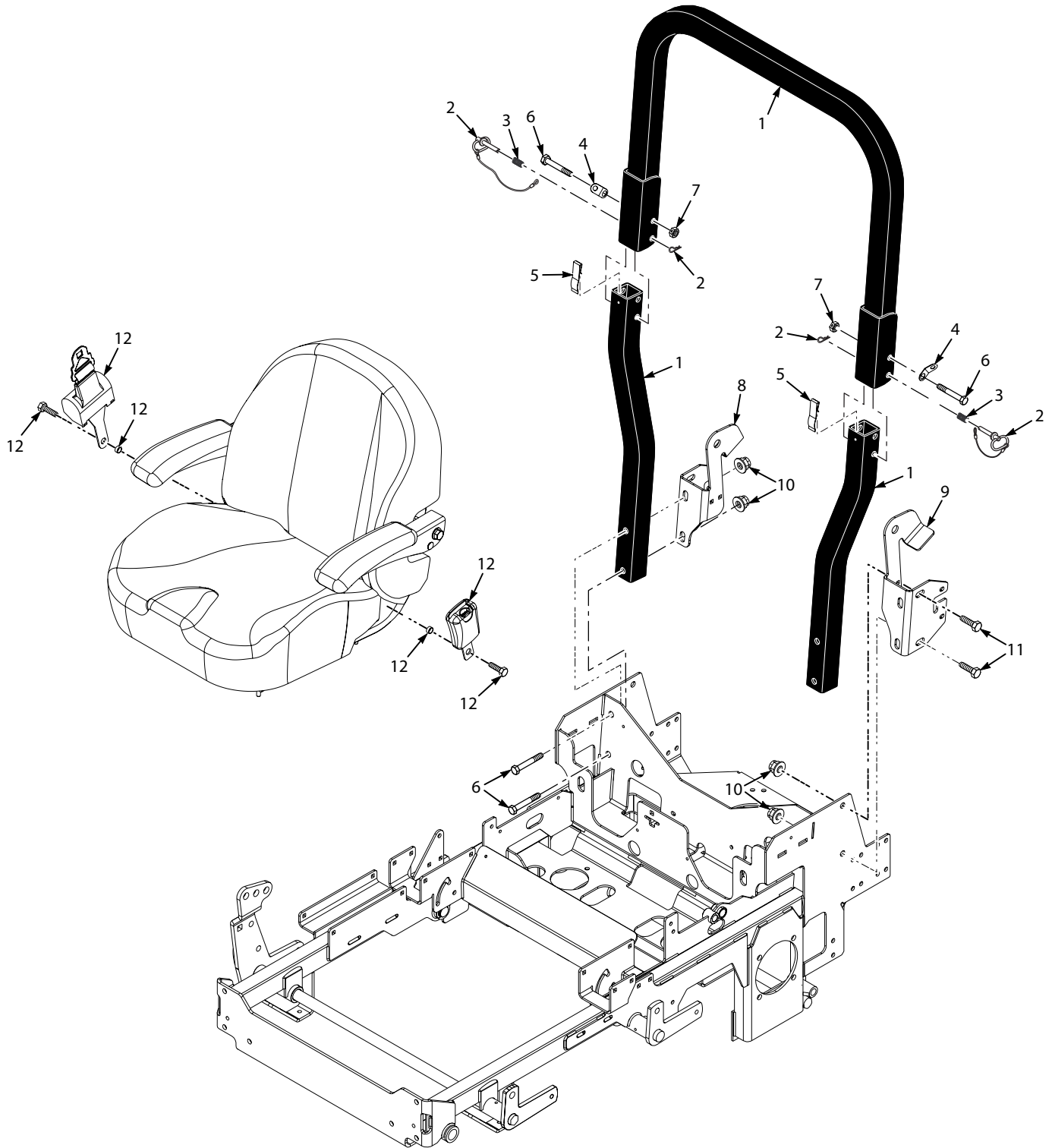

STCII FOLDABLE ROLL-OVER PROTECTION SYSTEM

Ref. No.	Part No.	Description
1	462414	ROPS Assembly, Foldable
2	484168	Pin Assembly (incl. #3)
3	484170	Spring, ROPS
4	484169	Clip, ROPS
5	484167	Spring, ROPS Anti-Rattle
6	04001-90	Bolt, Hex Head 1/2-13 x 3-1/4"
7	04021-07	Nut, Elastic Stop 1/2-13
8	427029	ROPS Mount, RH
9	427028	ROPS Mount, LH
10	04117-04	Nut, 1/2-13 Flange Elastic Stop
11	04001-70	Bolt, Hex Head 1/2-13 x 1-1/4"
12	484717	Seat Belt Kit (Suspension Seat)
	484527	Seat Belt Kit (Soft Ride Seat)

STCII SUSPENSION SEAT

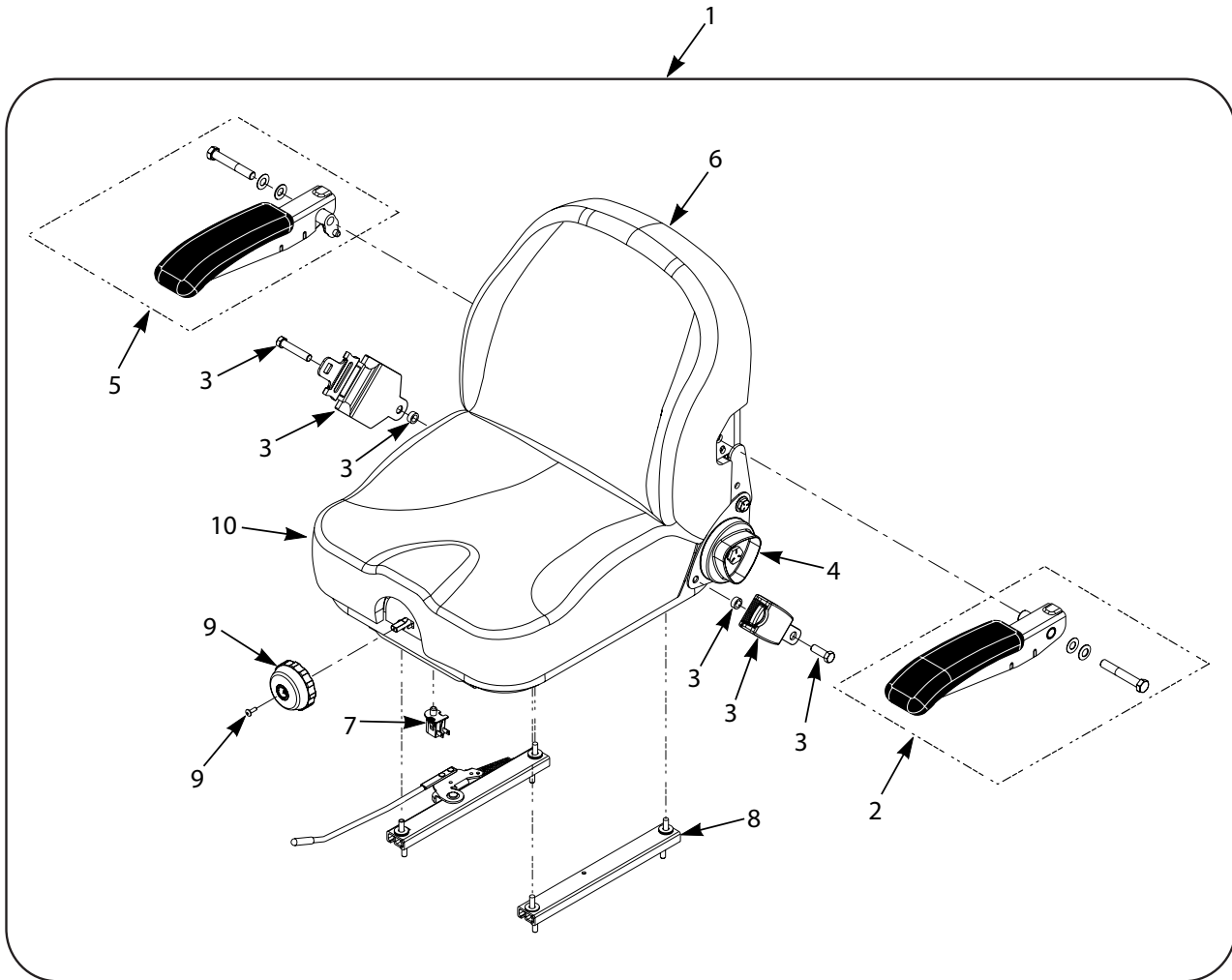

Ref. No.	Part No.	Description
1	485591	Suspension Seat Assembly w/seat belt
2	484709	Armrest Kit, LH
3	484717	Seat Belt Kit
4	485652	Recliner Knob Kit
5	484710	Armrest Kit, RH
6	484712	Back Cover
7	481638	Seat Switch
8	485594	Track Kit
9	484714	Suspension Knob Kit
10	484708	Cover, Seat Cushion

**STCII SOFT RIDE SEAT W/BLACK ARMRESTS
USED ON STCII-48V-22FS & STCII-61V-27BS MODELS**

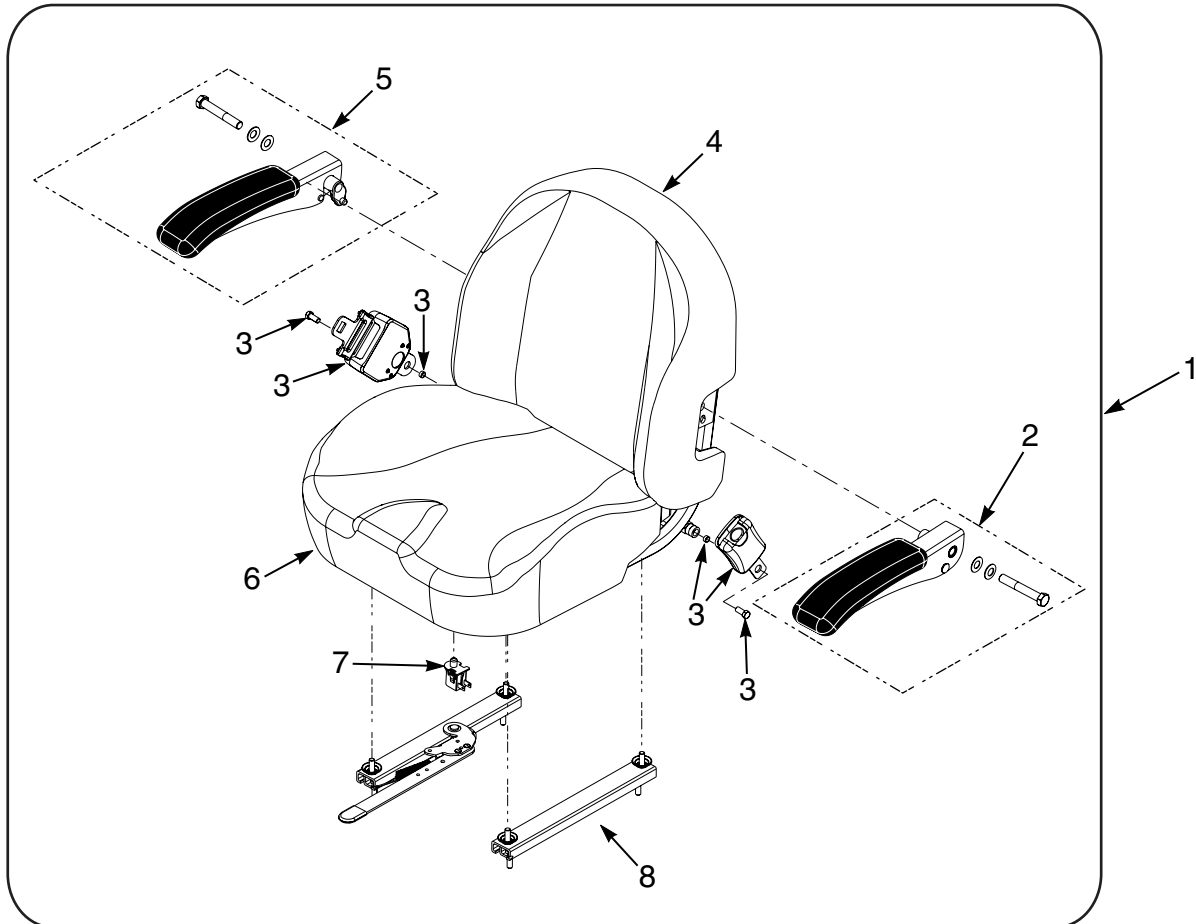

Ref. No.	Part No.	Description
1	485630	Seat Assembly
2	484709	Armrest Kit, LH
3	484527	Seat Belt Kit
4	484528	Back Cover
5	484710	Armrest Kit, RH
6	484529	Cover, Seat Cushion
7	481638	Seat Switch
8	485594	Track Kit

DRIVE SYSTEM COMPONENTS

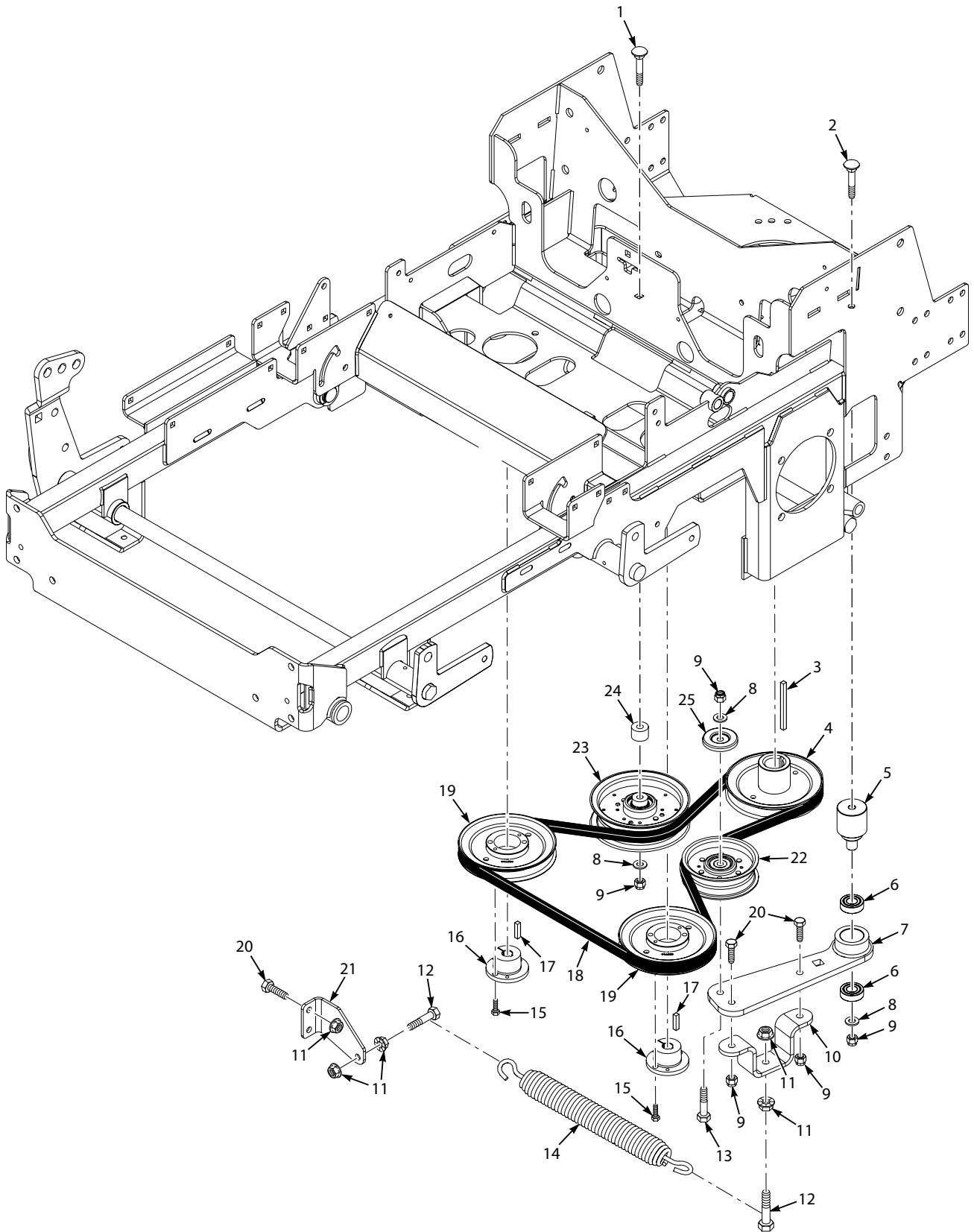

DRIVE SYSTEM COMPONENTS

Ref. No.	Part No.	Description
1	04003-47	Bolt, Carriage 3/8-16 x 3-1/4"
2	04003-26	Bolt, Carriage 3/8-16 x 4"
3	04063-28	Key, 1/4 x 1/4 x 3-1/2"
4	485589	Pulley, 5.75" Dia. - 1.125 Bore
5	431025	Pivot, Idler Arm
6	48224	Bearing
7	462860	Idler Arm Assembly (incl. #6)
8	04043-04	Flatwasher, 3/8-.391 x .938 x .105 HD
9	04021-09	Nut, Elastic Stop 3/8-16
10	425386	Mounting Bracket, Idler
11	04019-04	Nut, Serrated Flange 3/8-16
12	04001-136	Bolt, Hex Head 3/8-16 x 1-1/2" Grade 8
13	04001-31	Bolt, Hex Head 3/8-16 x 2-1/2"
14	484202	Spring, Pump Drive
15	04001-172	Bolt, Hex Head 1/4-20 x 1"
16	482085	Hub, Tapered, 15mm Bore
17	04063-14	Key, 5 x 5 x 25mm
18	485648	Belt, Pump Drive (48"/52")
	485649	Belt, Pump Drive (61")
19	482744	Pulley, 5.75" OD Taper Bore
20	04001-32	Bolt, Hex Head 3/8-16 x 1-1/4"
21	427016	Bracket, Spring Anchor
22	484128	Pulley, 4" Dia. Idler
23	483215	Pulley, 5" Dia. Idler
24	43286	Spacer
25	424367	Dust Shield

ENGINE & ATTACHING PARTS

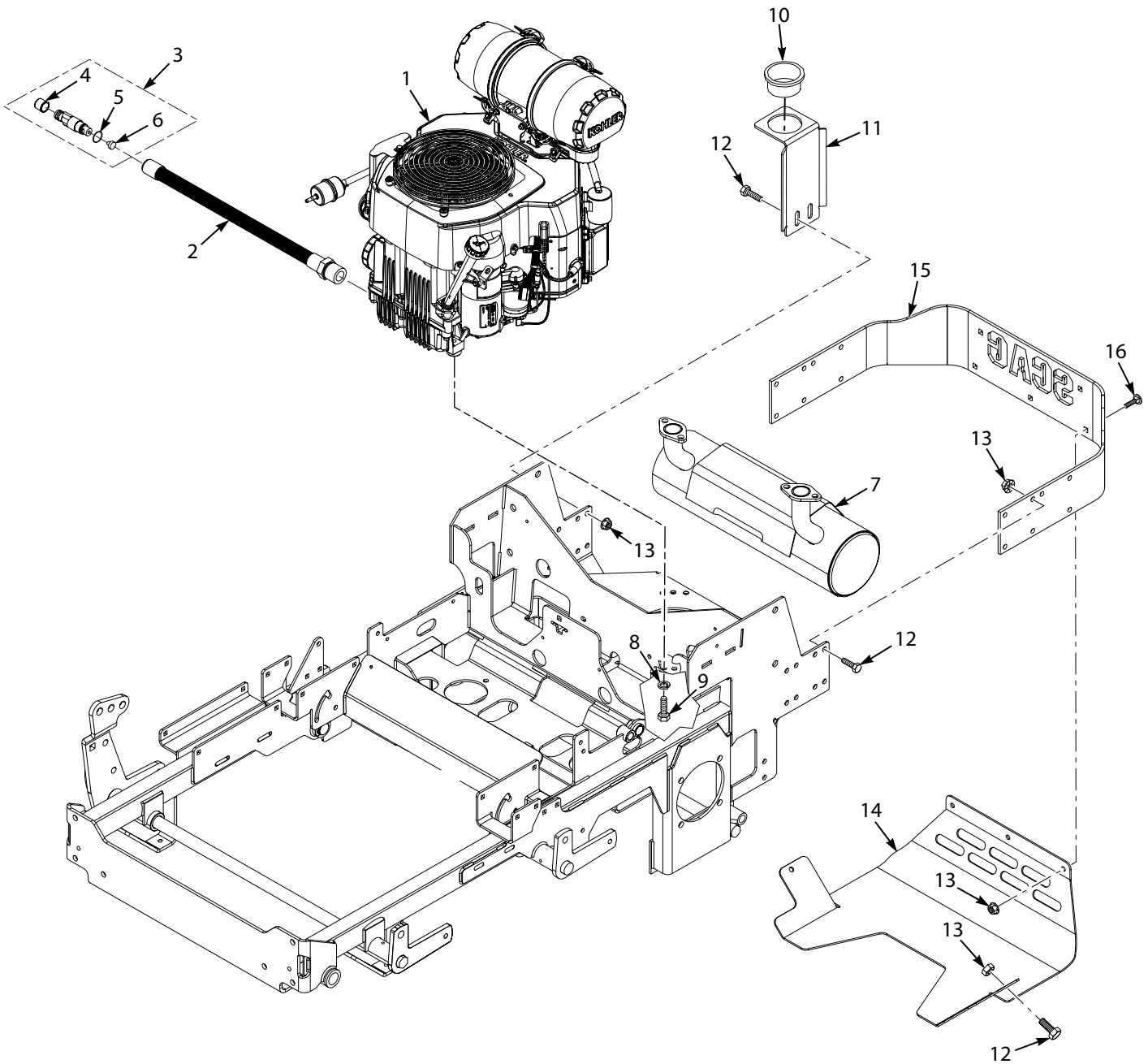

ENGINE & ATTACHING PARTS

Ref. No.	Part No.	Description
1	485029	Engine, Kawasaki 22FS
	485020	Engine, Kawasaki 22FX
	485021	Engine, Kawasaki 23FX
	485727	Engine, Kohler 23CV
	485728	Engine, Kohler 25CV-EFI
	485729	Engine, Kohler 26CV-EFI
2	484581	Hose, Oil Drain - Kawasaki FX / FS (incl. #3, 4, 5, 6)
	484706	Hose, Oil Drain - Kohler CV & CV-EFI (incl. #3, 4, 5, 6)
3	484583	Valve Assembly, Oil Drain
4	484585	Cap
5	48603-12	O-Ring
6	484586	Seal
7	485705	Muffler, Kawasaki FS/FX
	484568	Muffler, Kohler 23CV
	484650	Muffler, Kohler 25CV-EFI & 26CV-EFI
8	04030-04	Lockwasher, 3/8" Spring, Kawasaki FX / FS
9	04001-32	Bolt, Hex Head 3/8-16 x 1-1/4", Kawasaki FX / FS
	04011-07	Bolt, Hex Head 3/8-16 x 1-1/4" Self Tap, Kohler CV & CV-EFI
10	484617	Bushing, Thick Panel Snap
11	426040	Bracket, Oil Drain Hose
12	04001-19	Bolt, Hex Head 3/8-16 x 1"
13	04019-04	Nut, Serrated Flange 3/8-16
14	427032	Plate, Skid
15	425725	Bumper, Rear
16	04003-23	Bolt, Carriage 3/8-16 x 1"

STEERING COMPONENTS

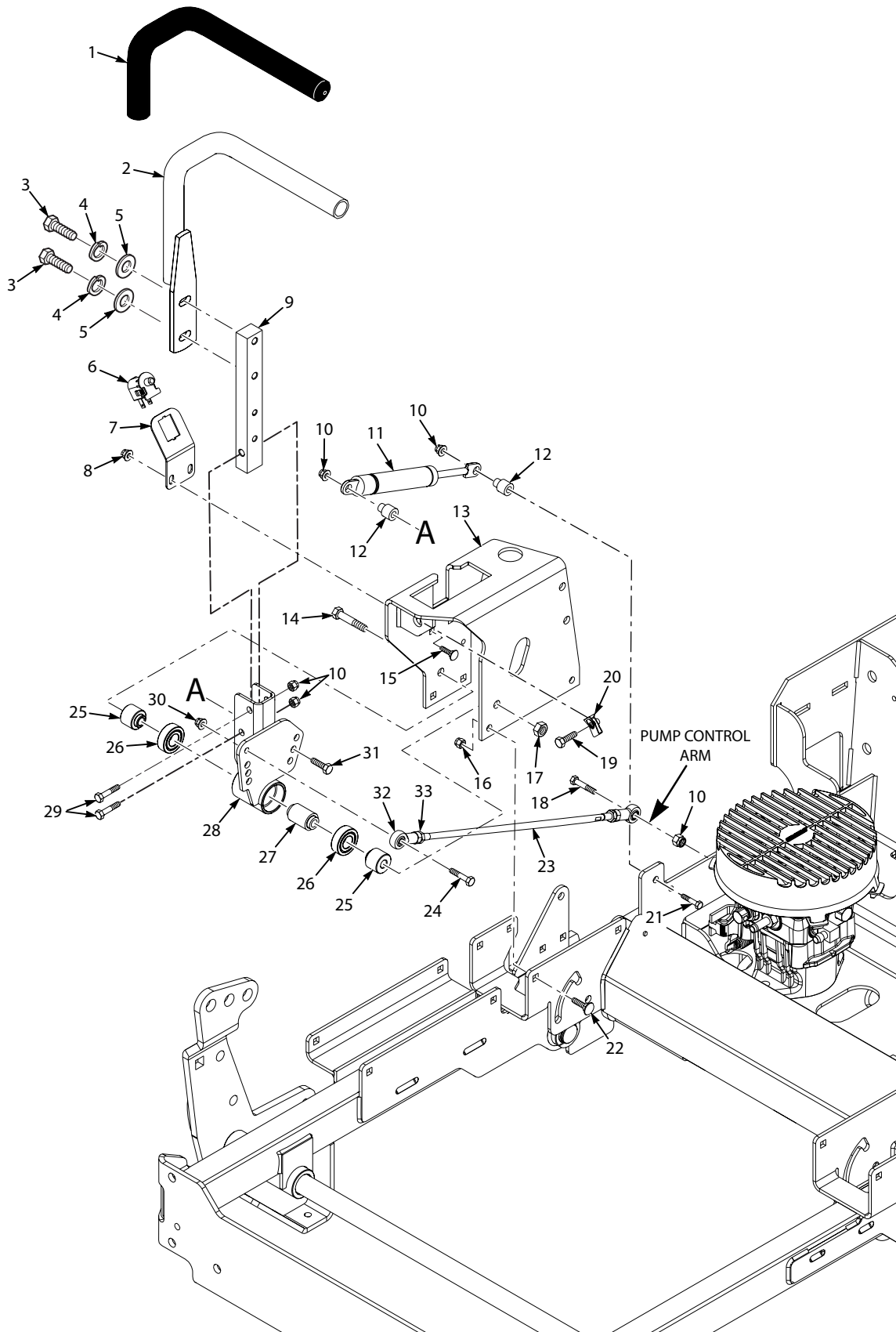

STEERING COMPONENTS

Ref. No.	Part No.	Description
1	484376	Grip, Control Handle
2	462401	Handle Bar w/Grip
3	04001-32	Bolt, Hex Head 3/8-16 x 1-1/4"
4	04030-04	Lockwasher, 3/8" Spring
5	04041-07	Flatwasher, 3/8-.391 x .938 x .105
6	481638	Switch, N/O
7	425905	Bracket, Operator Presence Switch
8	04117-03	Nut, Flanged Elastic Stop 1/4-20
9	422372	Bar, Control Lever
10	04021-10	Nut, Elastic Stop 5/16-18
11	484151	Gas Damper
12	43602	Spacer, Pump Dampener
13	462859	Bracket Weldment, Control Lever RH w/Decal
	462858	Bracket Weldment, Control Lever LH w/Decal
14	04001-152	Bolt, Hex Head 3/8-16 x 4-1/4"
15	04003-02	Bolt, Carriage 1/4-20 x 3/4"
16	04019-03	Nut, Serrated Flange 5/16-18
17	04021-05	Nut, Center Lock 3/8-16
18	04001-09	Bolt, Hex Head 5/16-18 x 1"
19	04107-03	Bolt, Hex Head 3/8-16 x 1-1/4" with Thread Lock Patch
20	04110-03	U-Nut, 3/8-16
21	04001-11	Bolt, Hex Head 5/16-18 x 1-1/2", RH
	04001-12	Bolt, Hex Head 5/16-18 x 1-3/4", LH
22	04003-12	Bolt, Carriage 5/16-18 x 3/4"
23	485583	Linkage Assy, Steering
	484073	Rod End, 5/16-24 LH
	04020-31	Nut, 5/16-24 UNF Jam
24	04001-04	Bolt, Hex Head 1/4-20 x 1-1/2"
25	43607	Spacer, Controls
26	48224	Bearing
27	43600	Spacer, Bearing
28	452731	Pivot Weldment, Control Arm RH
	452730	Pivot Weldment, Control Arm LH
29	04001-12	Bolt, Hex Head 5/16-18 x 1-3/4"
30	04021-08	Nut, Elastic Stop 1/4-20
31	04001-11	Bolt, Hex Head 5/16-18 x 1-1/2"
32	485584	Rod End, 5/16-24 RH
33	04020-30	Nut, 5/16-24 UNF LH Jam

BRAKE COMPONENTS

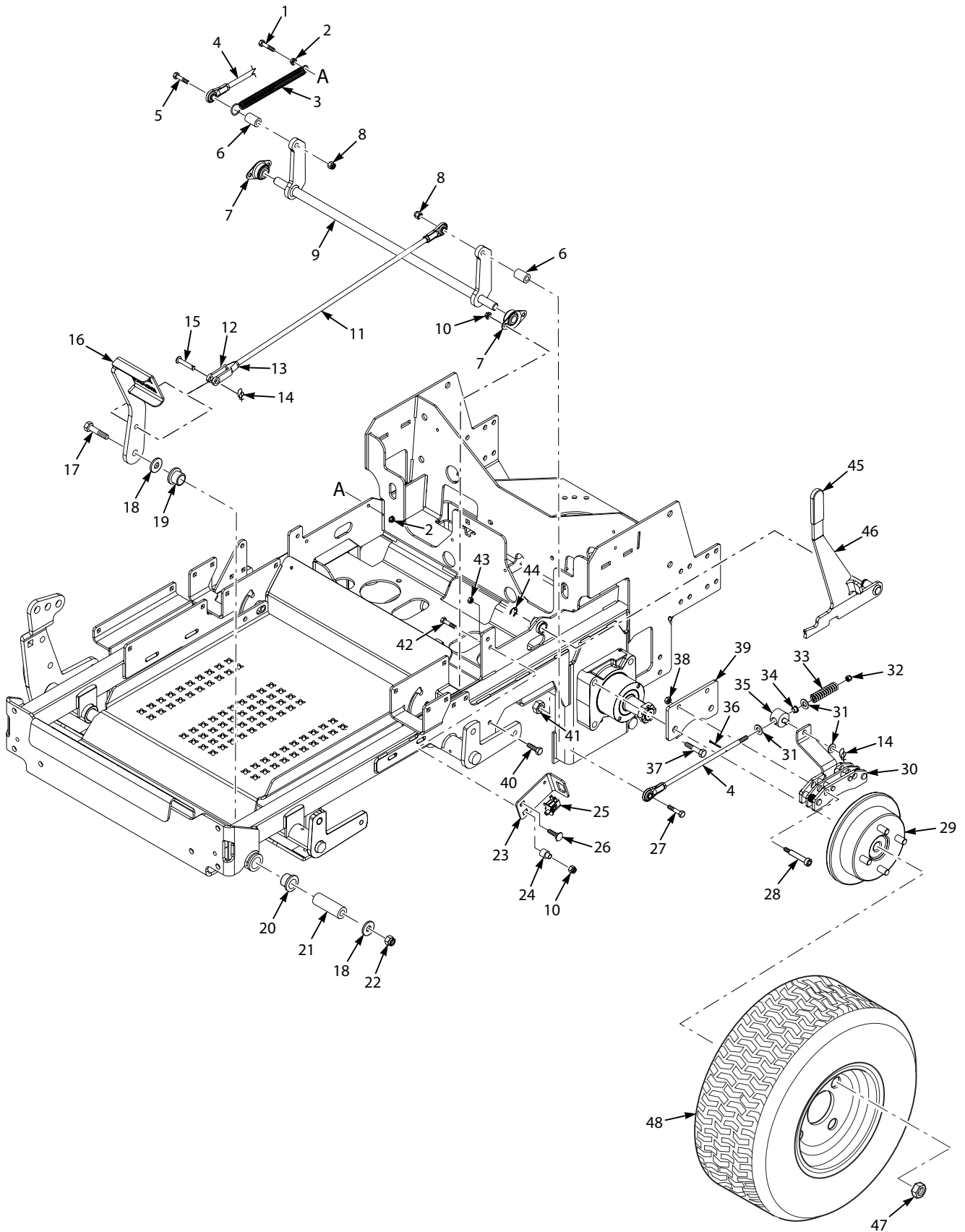

Section 8

BRAKE COMPONENTS

Ref. No.	Part No.	Description
1	04001-59	Bolt, Hex Head 1/4-20 x 1-1/4"
2	04019-02	Nut, Serrated Flange 1/4-20
3	485659	Spring, Brake Return
4	462465	Brake Link Assembly (incl. #31, 32, 33, 34, 35, 36)
5	04001-31	Bolt, Hex Head 3/8-16 x 2-1/2"
6	43572	Spacer
7	48796	Bearing, Self Align - 5/8" I.D.
8	04117-02	Nut, Flanged Elastic Stop 3/8-16
9	452342	Brake Bellcrank Weldment
10	04021-10	Nut, Elastic Stop 5/16-18
11	492001	Brake Rod Assembly
	483340	Rod End, 3/8-24 LH
	04020-26	Nut, 3/8-24 UNF LH Jam
12	48343-04	Clevis
13	04020-25	Nut, 3/8-24 UNF Jam
14	04069-01	Pin, Rue Cotter - 3/8" Dia.
15	04064-02	Clevis Pin, 3/8 x 1.06"
16	452327	Brake Pedal Weldment
17	04001-194	Bolt, Hex Head 1/2-13 x 4-1/4"
18	04040-13	Flatwasher, 1/2-.562 x 1.375 x .109
19	43872	Sleeve, Brake Pivot
20	483453-03	Bearing
21	43872	Sleeve, Brake Pivot
22	04021-07	Nut, Elastic Stop 1/2-13
23	426992	Switch Mounting Bracket, Brake
24	43602	Spacer
25	481638	Switch
26	04003-02	Bolt, Carriage 1/4-20 x 3/4"
27	04001-54	Bolt, Hex Head 3/8-16 x 3"

Ref. No.	Part No.	Description
28	04009-10	Bolt, 1/2 x 2-3/4" Shoulder
29	462808	Brake Hub
30	485595	Brake Caliper
31	04040-05	Flatwasher, 3/8-.406 x .812 x .065
32	04021-18	Nut, Elastic Stop 3/8-24
33	484535	Spring, Brake
34	483453-23	Bearing
35	462452	Swivel Assembly, Brake
36	04061-02	Cotter Pin, 3/32 x 3/4"
37	04001-190	Bolt, Hex Head 1/2-13 x 2-3/4"
38	04021-05	Nut, Center Lock 3/8-16
39	426983	Mounting Bracket, Brake
40	04001-08	Bolt, Hex Head 5/16-18 x 3/4"
41	04021-09	Nut, Elastic Stop 3/8-16
42	04001-12	Bolt, Hex Head 5/16-18 x 1-3/4"
43	04021-08	Nut, Elastic Stop 1/4-20
44	04050-01	Retaining Ring, .625 Ext "E"
45	482102	Grip, Brake Lever
46	462820	Lever w/Grip, Parking Brake
47	04028-02	Wheel Nut, 1/2-20
48	485586	Wheel Assy 24 x 9.5-12 (48" Deck)
	485587	Rim (48" Deck)
	484105	Wheel Assy 24 x 9.5-12 (52" Deck)
	481659	Rim (52" Deck)
	484104	Tire 24 x 9.5-12 (48" & 52" Deck)
	481850	Wheel Assy 24 x 12-12 (61" Deck)
	481851	Rim (61" Deck)
	481852	Tire 24 x 12-12 (61" Deck)

HYDRAULIC SYSTEM

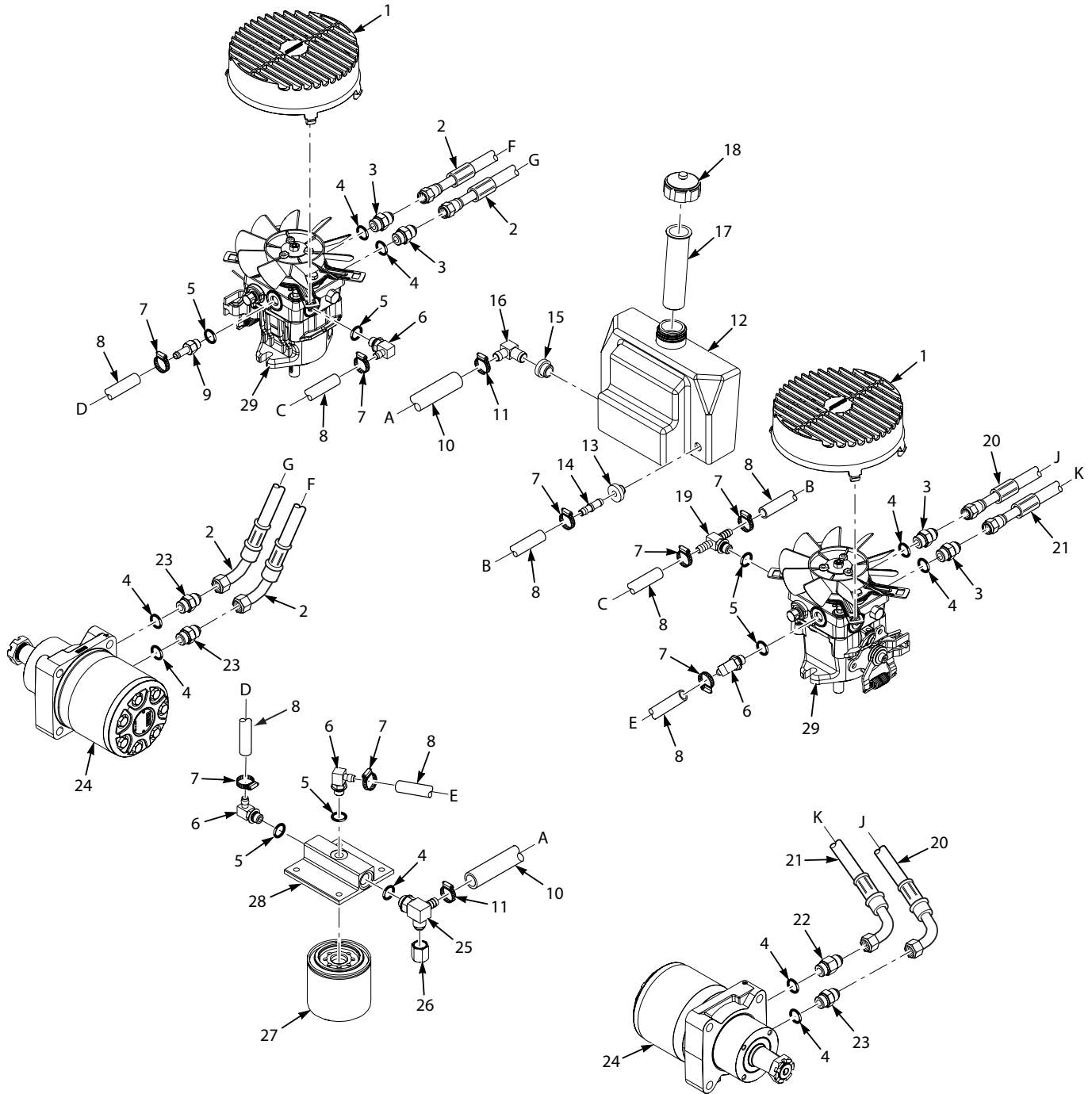

HYDRAULIC SYSTEM

Ref. No.	Part No.	Description
1	485564	Fan Cover, Pump
2	484452	Hose Assembly
3	48572-04	Fitting, 1/2" JIC x 1/2" O-Ring
4	48603-02	O-Ring, 3/4"
5	48603-06	O-Ring, 7/16"
6	482266-01	Elbow, 90 Degree 9/16" O-Ring x 3/8" Hose
7	48136-13	Hose Clamp, .69" Dia.
8	48811	Hose, 3/8" Pushlock (order by inch)
9	482800-02	Fitting, 9/16" O-Ring x 3/8" Hose
10	48351	Hose, 1/2" Pushlock (order by inch)
11	48136-05	Hose Clamp, .87" Dia.
12	462801	Hydraulic Tank Assy (incl. #13, 14, 15, 16, 17, 18)
13	482571	Bushing
14	485590	Fitting, Straight
15	482573	Bushing
16	482574	Fitting
17	481507	Insert, Filler Neck
18	481164	Cap, Hydraulic Tank
19	482277	Tee Fitting, O-Ring to Barb
20	485603	Hose Assembly
21	485602	Hose Assembly
22	48572-10	Fitting, 1/2" JIC x 5/8" O-Ring (LH Wheel Motor - Upper Port Only)
23	48572-02	Fitting, 1/2" JIC x 5/8" O-Ring
24	482639	Wheel Motor, Parker
25	482483	Tee, 3/4" O-Ring x JIC x 1/2" Hose
26	48571-02	Cap
27	48462-01	Oil Filter
28	482417	Oil Filter Base
29	485573	Pump, LH (PK-3KCC-GA1F-XXXX)
	485574	Pump, RH (PK-3HCC-GA1F-XXXX)

STCII FUEL SYSTEM

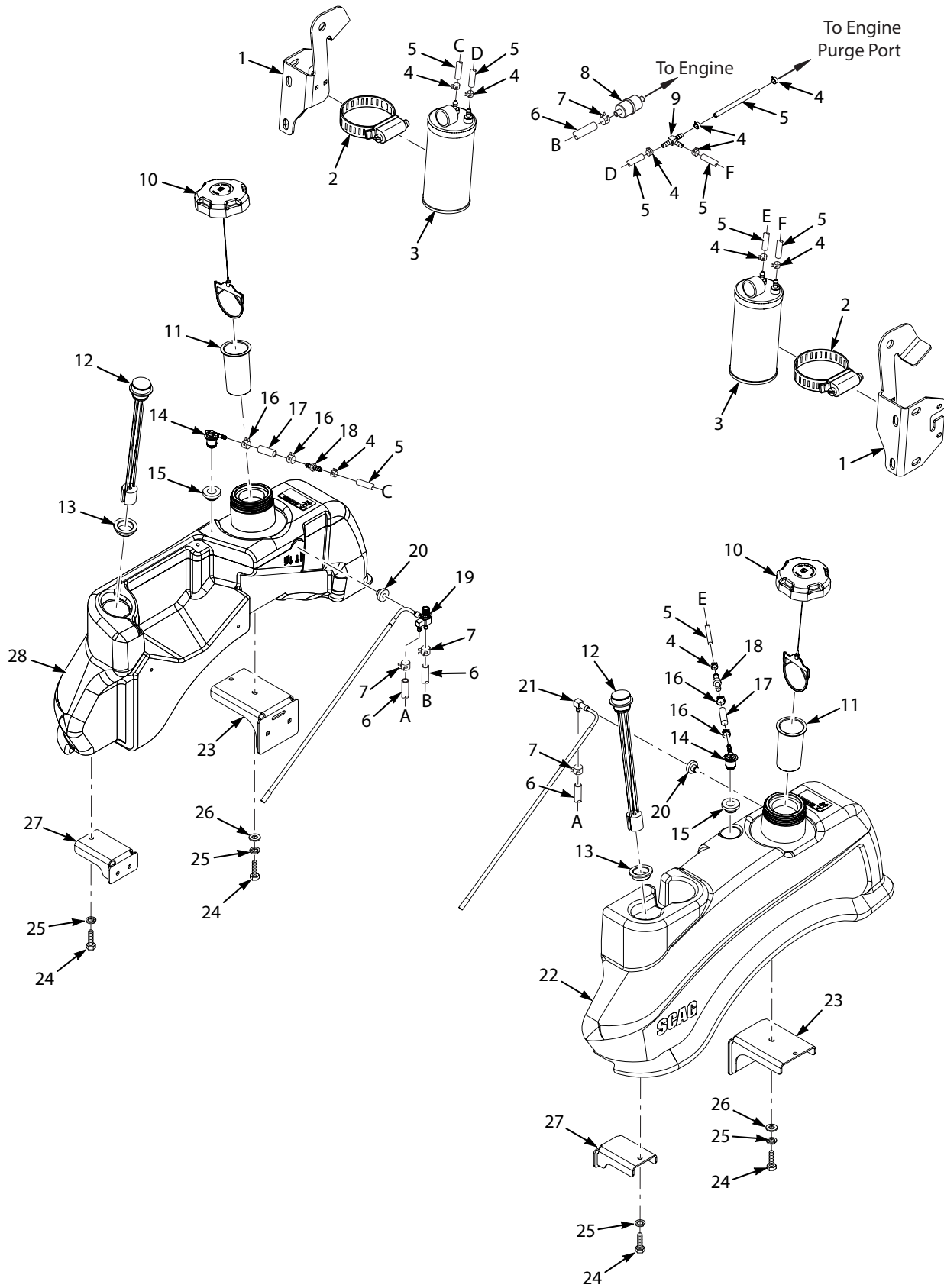

STCII FUEL SYSTEM

Ref. No.	Part No.	Description
1	427028	ROPS Mount, LH
	427029	ROPS Mount, RH
2	48136-17	Clamp
3	484287	Carbon Canister, 400cc
	484366	Dust Filter, Carbon Canister
4	48059-05	Clamp, Vapor Recovery Hose
5	484345	Hose, 3/16" (order by inch)
6	483617	Hose, Non-Perm Fuel 1/4" I.D.
7	48059-01	Clamp, Fuel Hose 1/4" I.D.
8	**	Fuel Filter
9	48935-02	Tee, 3/16 x 3/16 x 3/16 Union, Hose Barb
10	484286	Fuel Cap, Tethered
	484297	Fuel Cap, Tethered (California Only)
11	484279-01	Tube, Fuel Tank Insert - 4"
12	484323	Fuel Gauge Assembly (incl. #13)
13	484242	Seal, Fuel Gauge
14	484333	Remote Vent
15	484285	Grommet, Viton
16	48059-02	Clamp, Fuel Hose 7/32
17	484347	Hose, Vapor Recovery (order by inch)
18	484343-01	Mender, 1/4 x 3/16
19	485637	Fuel Tube Assembly, Includes Valve
20	482571	Bushing, .56 Viton
21	484552	Fuel Tube Assembly, LH
22	462830	Fuel Tank Assembly, LH (incl. # 12, 14, 15, 20, 21)
23	427063	Mounting Bracket, Fuel Tank Rear
24	04001-08	Bolt, Hex Head 5/16-18 x 3/4"
25	04030-03	Lockwasher, 5/16" Spring
26	04040-15	Flatwasher, 5/16-.375 x .875 x .083
27	425862	Mounting Bracket, Fuel Tank Front
28	462831	Fuel Tank Assembly, RH (incl. #12, 14, 15, 19, 20)

** = Available through engine manufacturer only.

ELECTRICAL SYSTEM

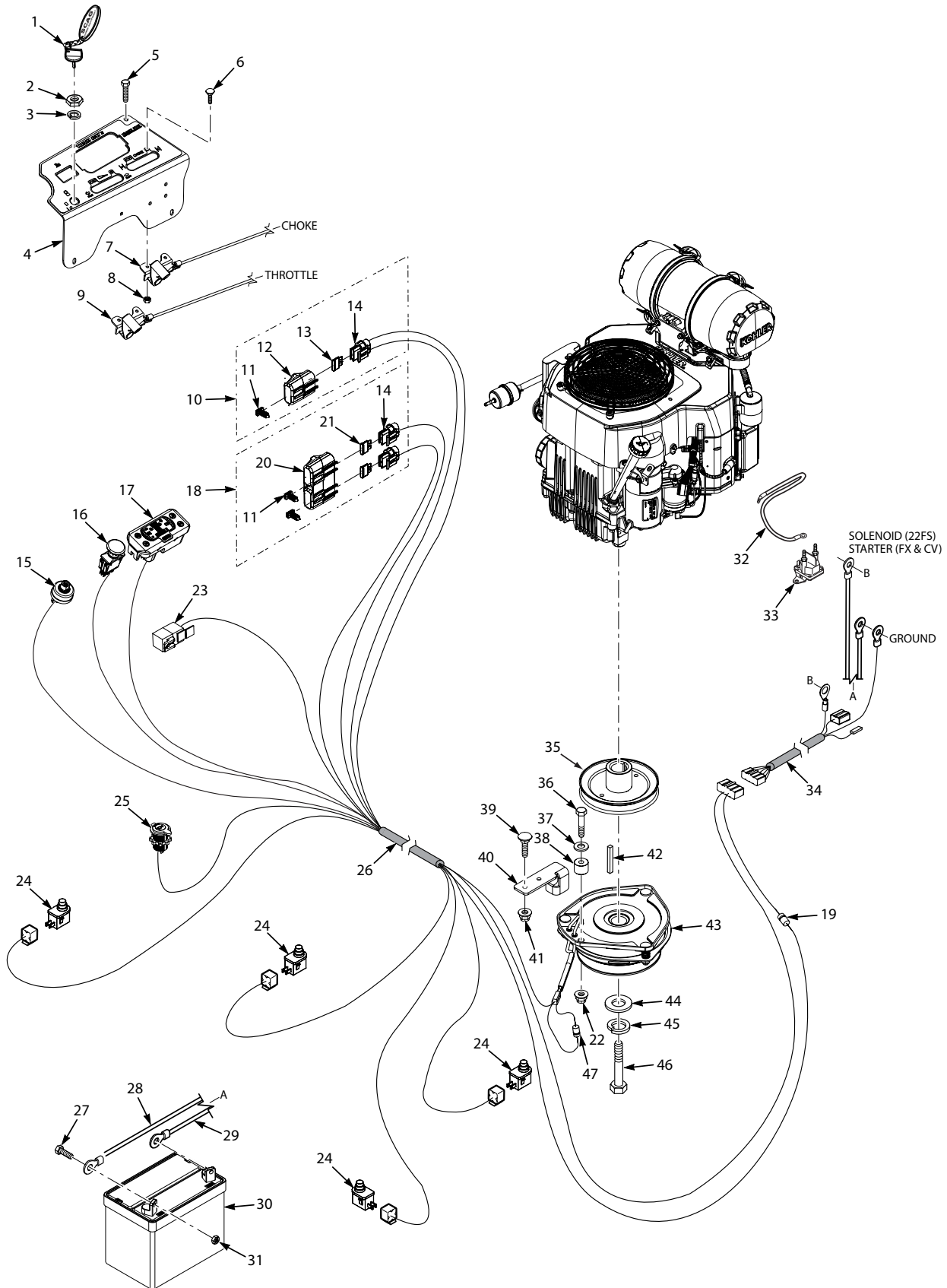

Section 8

ELECTRICAL SYSTEM

Ref. No.	Part No.	Description
1	483366	Key, Ignition
2	48017-04	Nut, Hex 5/8-32
3	48017-03	Lockwasher, 5/8" Internal
4	462862	Instrument Panel w/Decal
5	04017-04	Bolt, Hex Head Serrated Flange 1/4-20 x 1/2"
6	04003-43	Bolt, Carriage #10-24 x 1/2"
7	485628	Choke Control Cable (Kawasaki FS / FX)
	485610	Choke Control Cable (Kohler CV)
8	04021-26	Locknut, #10-24
9	485628	Throttle Control Cable (Kawasaki FS / FX, Kohler CV)
10	485739	Single Fuse Assy. (incl. #11, 12, 14)
11	482588	Clip, Wire
12	483643	Cover, Sealed Single
13	485674	Fuse, 5 Amp
14	483629	Fuse Holder
15	48798	Switch, Starter
16	483957	Switch, PTO
17	484721	Cluster Gauge
18	483642	Double Fuse Assy. (incl. #11, 14, 20, 21)
19	482253	Diode
20	483571	Cover, Sealed Double
21	48298	Fuse, 20 Amp
22	04021-10	Nut, Elastic Stop 5/16-18
23	483013	Relay
24	481638	Switch
25	485568	Power Plug
26	485640	Wire Harness
27	04001-44	Bolt, Hex Head 1/4-20 x 1/2"
28	48029-28	Battery Cable, 25" Red
29	48029-11	Battery Cable, 27" Black
30	*	Battery, 350 CCA
31	04020-02	Nut, 1/4-20 UNC
32	48029-09	Battery Cable, Red 9" (Kawasaki 22FS)
33	483278	Solenoid, Sealed (Kawasaki 22FS)
34	485679	Wire Harness Adapter, Kawasaki - 22FS
	485678	Wire Harness Adapter, Kawasaki - 22FX & 23FX
	485673	Wire Harness Adapter, Kohler - 23CV
35	485589	Pulley, 5.75" Dia. - 1.125 Bore
36	04001-11	Bolt, Hex Head 5/16-18 x 1-1/2"
37	04040-15	Flatwasher, 5/16-.375 x .875 x .083
38	431009	Bushing, UHMW
39	04003-12	Bolt, Carriage 5/16-18 x 3/4"
40	427330	Anti-Rotation Bracket
41	04117-01	Nut, Flange Elastic Stop 5/16-18
42	04063-28	Key, 1/4 x 1/4 x 3-1/2"
43	484276	Clutch, GT3.5 - 1.125 Bore
44	04041-28	Flatwasher, 7/16-.469 x 1.75 x .25
45	04030-05	Lockwasher, 7/16" Spring
46	04102-03	Bolt, Hex Head 7/16-20 x 2-1/4" w/Patch
47	483958	Diode, 600V - 6A

* = Not available through Scag.

ELECTRICAL SYSTEM - KOHLER EFI

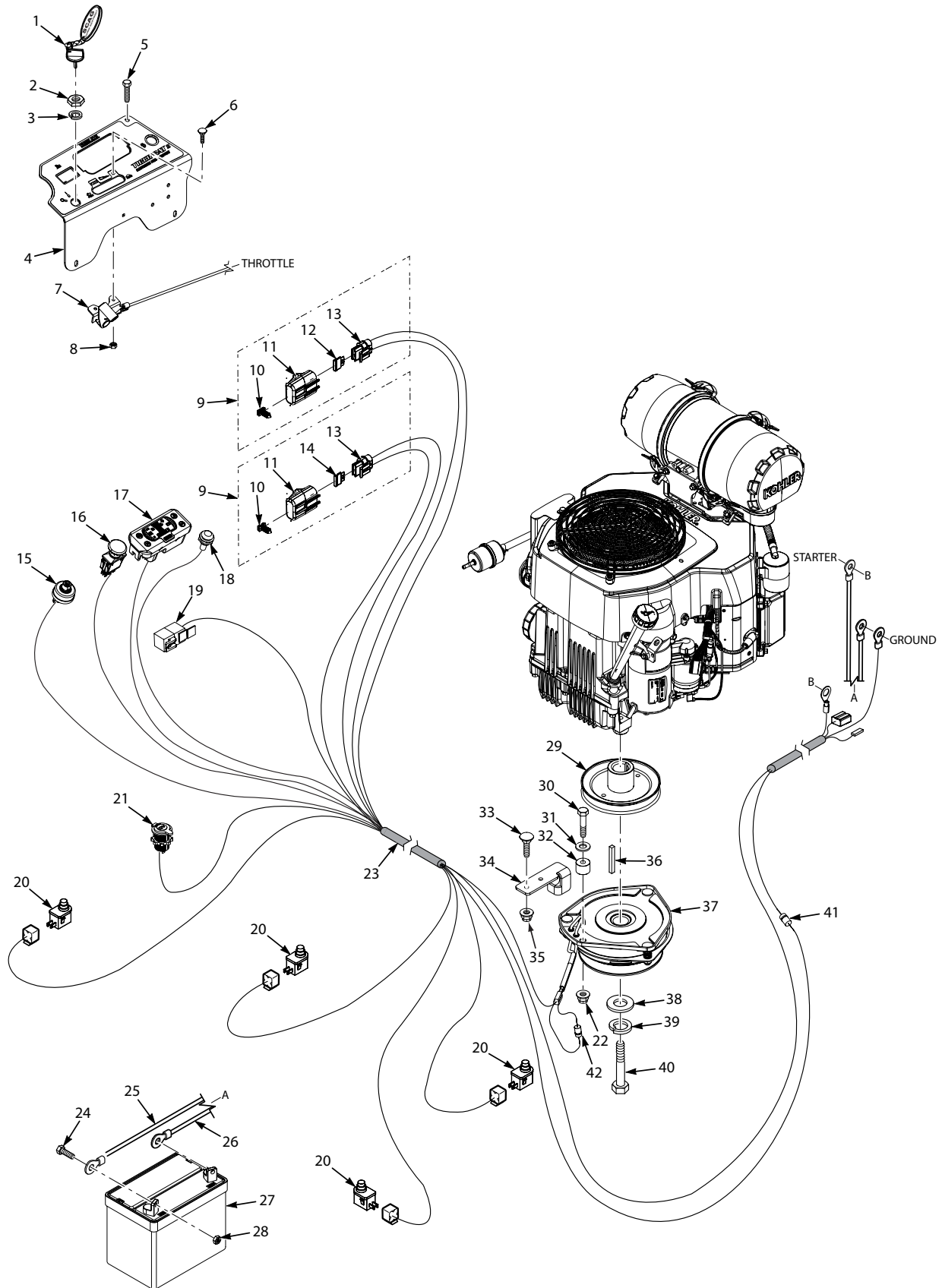

Section 8

ELECTRICAL SYSTEM - KOHLER EFI

Ref. No.	Part No.	Description
1	483366	Key, Ignition
2	48017-04	Nut, Hex 5/8-32
3	48017-03	Lockwasher, 5/8" Internal
4	462862	Instrument Panel w/Decal
5	04017-04	Bolt, Hex Head Serrated Flange 1/4-20 x 1/2"
6	04003-43	Bolt, Carriage #10-24 x 1/2"
7	485628	Throttle Control Cable
8	04021-26	Locknut, #10-24
9	485739	Single Fuse Assy. (incl. #10, 11, 13)
10	482588	Clip, Wire
11	483643	Cover, Sealed Single
12	485674	Fuse, 5 Amp
13	483629	Fuse Holder
14	48298	Fuse, 20 Amp
15	48798	Switch, Starter
16	483957	Switch, PTO
17	484721	Cluster Gauge
18	481182	Indicator Light
19	483013	Relay
20	481638	Switch
21	485568	Power Plug
22	04021-10	Nut, Elastic Stop 5/16-18
23	485641	Wire Harness, STCII-CV-EFI
24	04001-44	Bolt, Hex Head 1/4-20 x 1/2"
25	48029-28	Battery Cable, 25" Red
26	48029-11	Battery Cable, 27" Black
27	*	Battery, 350 CCA
28	04020-02	Nut, 1/4-20 UNC
29	485589	Pulley, 5.75" Dia. - 1.125 Bore
30	04001-11	Bolt, Hex Head 5/16-18 x 1-1/2"
31	04040-15	Flatwasher, 5/16-.375 x .875 x .083
32	431009	Bushing, UHMW
33	04003-12	Bolt, Carriage 5/16-18 x 3/4"
34	427330	Anti-Rotation Bracket
35	04117-01	Nut, Flange Elastic Stop 5/16-18
36	04063-28	Key, 1/4 x 1/4 x 3-1/2"
37	484276	Clutch, GT3.5 - 1.125 Bore
38	04041-28	Flatwasher, 7/16-.469 x 1.75 x .25
39	04030-05	Lockwasher, 7/16" Spring
40	04102-03	Bolt, Hex Head 7/16-20 x 2-1/4" w/Patch
41	482253	Diode
42	483958	Diode, 600V - 6A

* = Not available through Scag.

STCII HYDRAULIC PUMP ASSEMBLY

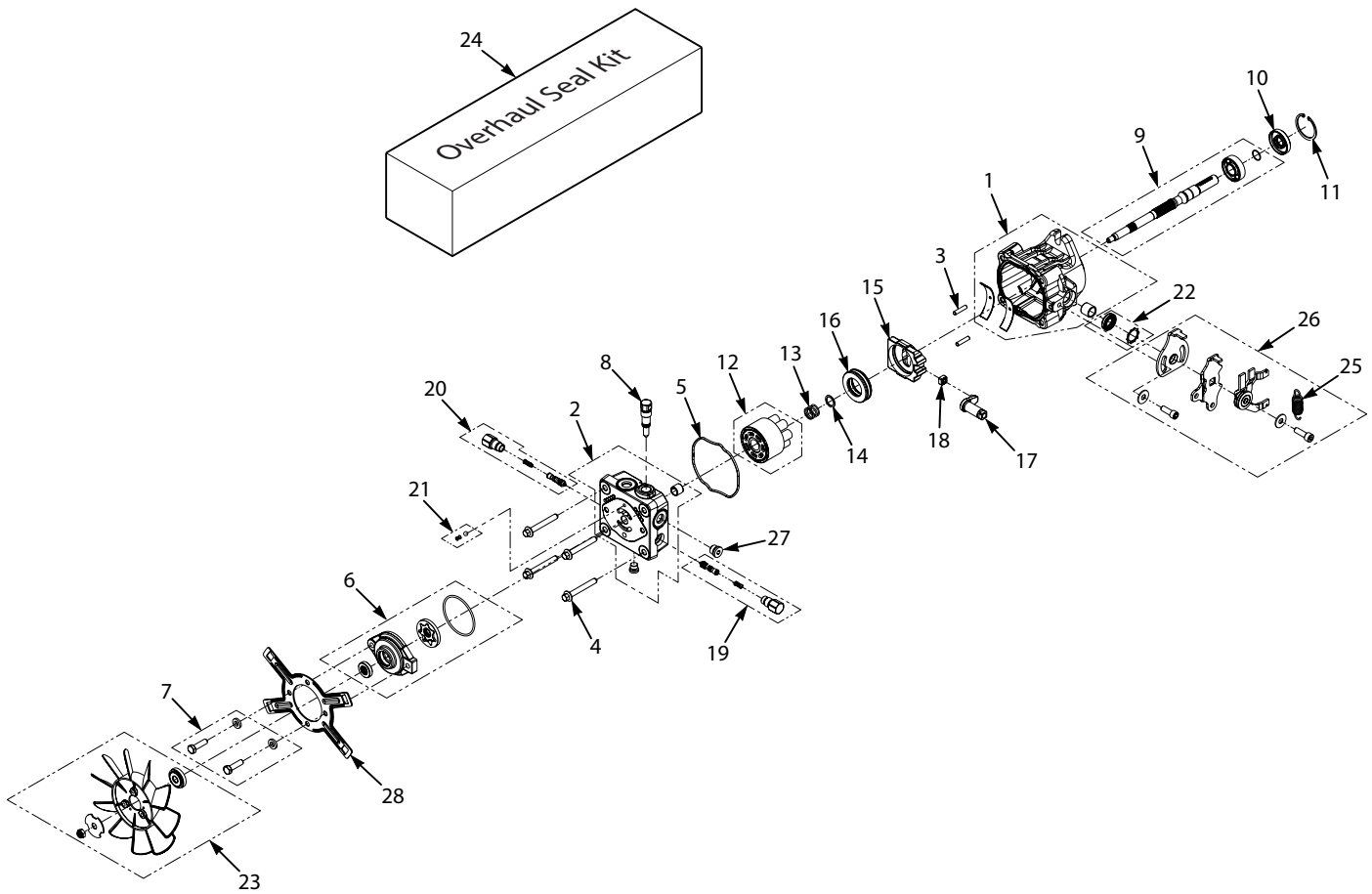

STCII HYDRAULIC PUMP ASSEMBLY

Ref. No.	Part No.	Description
1	HG 71717	Housing Kit
2	HG 72011	End Cap Kit
3	HG 50641	Straight Headless Pin
4	HG 50969	Hex Flange Bolt, M8-1.25 x 60mm
5	HG 54022	Housing O-Ring
6	HG 71247	Charge Pump Kit
7	HG 72254	Charge Pump Bolt Kit
8	HG 2513030	Bypass Valve Kit
9	HG 70620	Pumpshaft Kit
10	HG 51161	Lip Seal
11	HG 50329	Retaining Ring (Internal)
12	HG 71971	Cylinder Block Kit
13	HG 2003014	Block Spring
14	HG 2003017	Flat Washer
15	HG 2003087	Swash Plate
16	HG 53502	Thrust Bearing
17	HG 52866	Trunnion Arm
18	HG 2000015	Slot Guide
19	HG 70743	Shock Valve Kit (.031" Orifice)
20	HG 70743	Shock Valve Kit (.031" Orifice)
21	HG 70402	Charge Relief Kit
22	HG 2513043	Trunnion Seal with Retainer
23	HG 70811	Fan/Hub Kit
24	HG 70525	Overhaul Seal Kit
25	HG 52401	Spring, Extension
26	HG 71716	RTN Kit (Std Scissor, Std Spring)
27	HG 9005110-5600	Straight Thread Plug
28	HG 52355	Bracket

REPLACEMENT DECALS AND INFORMATION PLATES



1

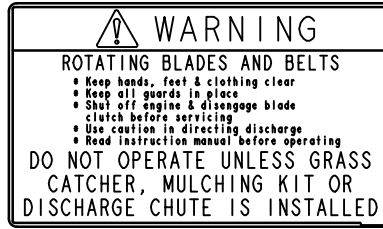

2



3

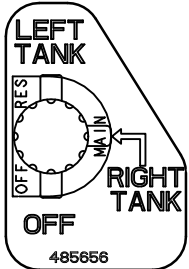

4

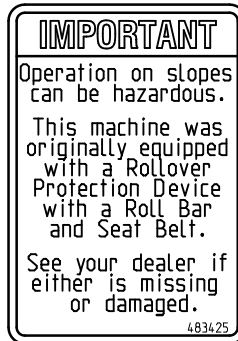

6

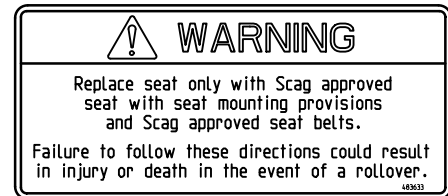

7



5



8

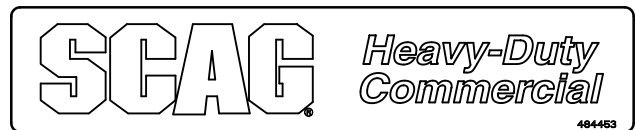

9

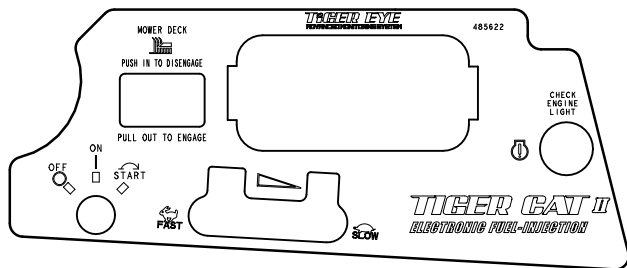

10

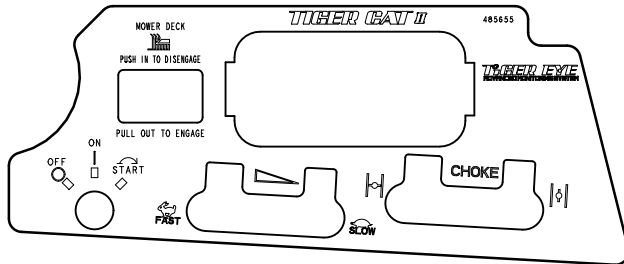

11



12



13

REPLACEMENT DECALS AND INFORMATION PLATES

Ref. No.	Part No.	Description
1	483407	Decal, Danger-Spinning Blades
2	483406	Decal, Warning-Rotating Blades
3	485403	Decal, Metalcraft - USA
4	485656	Decal, Fuel Valve Position
5	482100	Decal, Traction Control
6	483425	Decal, ROPS
7	483633	Decal, Seat Replacement
8	483402	Decal, Belt Cover
9	484453	Decal, Heavy Duty Commercial
10	485622	Decal, Instrument Panel - EFI
11	485655	Decal, Instrument Panel
12	484134	Decal, Deck Height - LH
13	484135	Decal, Deck Height - RH
14	485629	Decal, Tiger CatII
15	483199	Decal, 48V
	483200	Decal, 52V
	483201	Decal, 61V
16	485654	Decal, Seat Support
17	485521	Decal, Belt Routing (48V & 52V)
	485522	Decal, Belt Routing (61V)
18	485633	Decal, STCII Replacement Parts
**	462893	Spanish Decal Kit, (not shown)
**	01411	DVD Video, Tips for Safe Operation of Your Scag Zero-Turn Mower



14

IMPORTANT ADJUSTMENT PROCEDURES
 READ OPERATOR'S MANUAL FOR MORE DETAILS
 Check tire pressure - (Drive Tires-12 psi)
 - (Caster Tires-25 psi)

NEUTRAL ADJUSTMENT
 Loosen jam nuts

Rotate turnbuckle

With an operator in the seat, engine running, control lever in neutral and the parking brake disengaged - adjust control linkage. Loosen jam nuts. If wheel rotates forward, adjust turnbuckle CW. If wheel rotates rearward, adjust turnbuckle CCW. Adjust until drive wheel stops turning. Tighten jam nuts. Repeat procedure until proper Neutral Adjustment is obtained.

TRACKING ADJUSTMENT
 If the machine pulls to the right, adjust LH control linkage CW to slow left wheel. If the machine pulls to the left adjust RH control linkage CW to slow right wheel. Readjust neutral if necessary.

FREE WHEEL OPERATION
 To move machine without running the engine, rotate both dump valves located at the LH side of the pumps CW 1/2 turn to "free-wheel" positions. Return dump valves to original position to operate the mower. Tighten to 7-10 ft-lbs.

HYDRAULIC FLUID LEVEL
 Check hydraulic fluid level while fluid is cool. Fluid level should be 3" below top of filler neck. Fill with SAE 20W50 motor oil only.

IMPORTANT
 Do not overfill. Room for hot fluid expansion must be allowed or resulting expansion may cause leaks in the system

485654

16

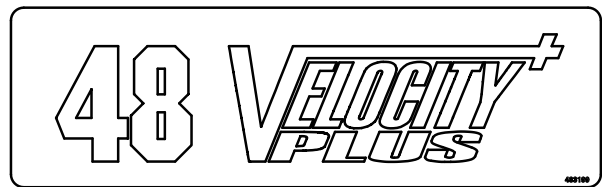

15

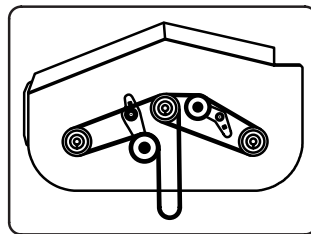

17

Replacement Parts Numbers TIGER CAT II
 Always use original Scag replacement parts for top machine performance and to maintain factory warranty.

Belt, Pump Drive (48" & 52")	485648	Standard Blade, Cutter (48")	482877
Belt, Pump Drive (61")	485649	Standard Blade, Cutter (52")	482878
Belt, Cutter Deck-LH (48")	485634	Standard Blade, Cutter (61")	482879
Belt, Cutter Deck-RH (48")	483238	Spindle Grosse: Mobligrasso XHP™ 222	
Belt, Cutter Deck-LH (52")	485635	Econ Mobile Ramox MP	
Belt, Cutter Deck-RH (52")	483240	Econ Mobile Unirex EP2	
Belt, Cutter Deck-LH (61")	485636	Filter, Hydraulic (10 micron)	48462-01
Belt, Cutter Deck-RH (61")	48367		

See your authorized Scag dealer for engine part numbers.

18

STCII ELECTRICAL SCHEMATIC

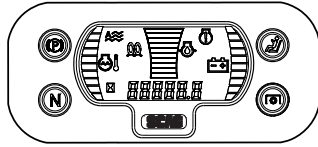

Position	Key Switch Legend
OFF	G + M + A
RUN	B + L + A
START	B + L + S

Position	PTO Switch Legend	
OFF	-	H + F C + D
ON	B + C	G + H E + A

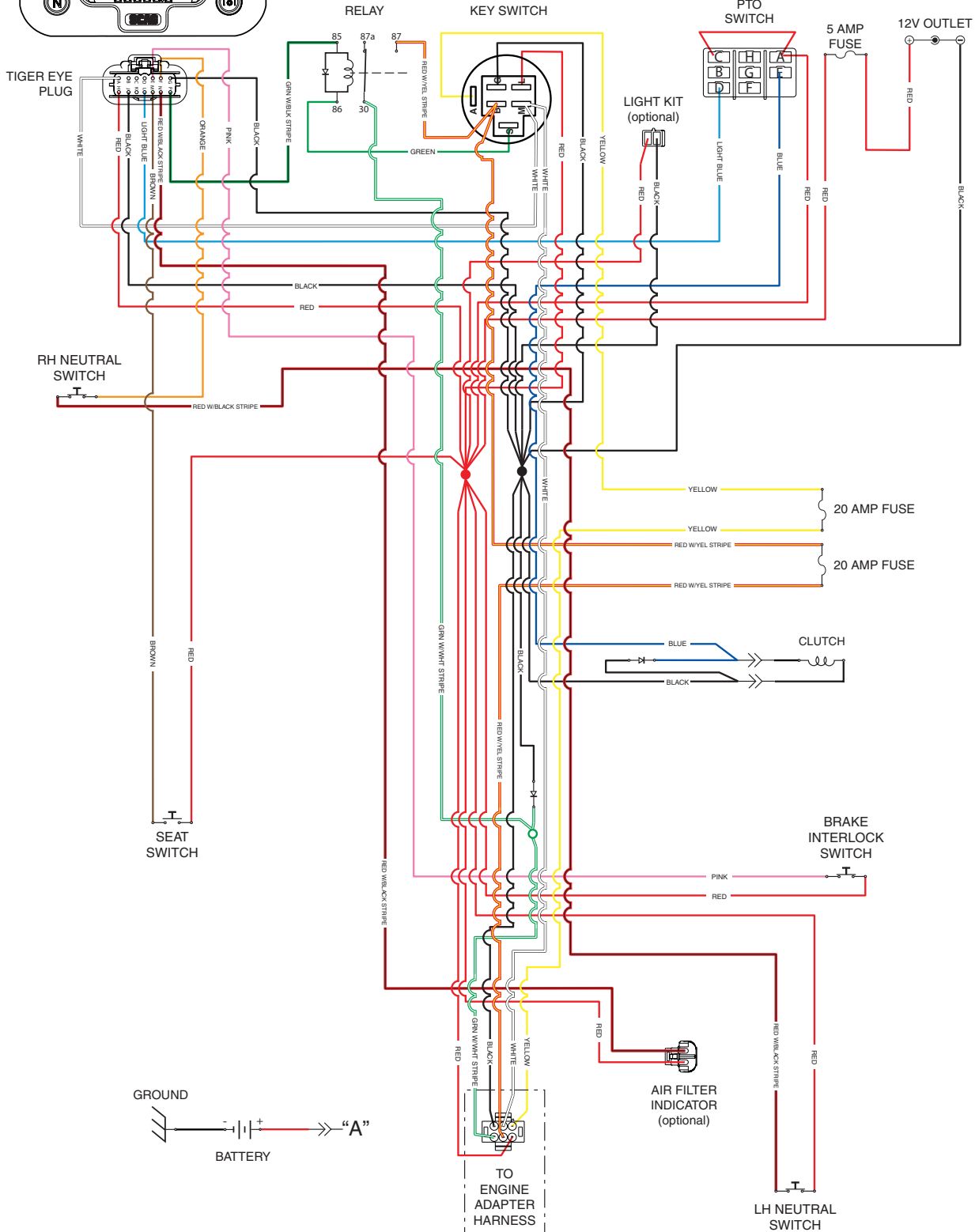

STCII-EFI ELECTRICAL SCHEMATIC

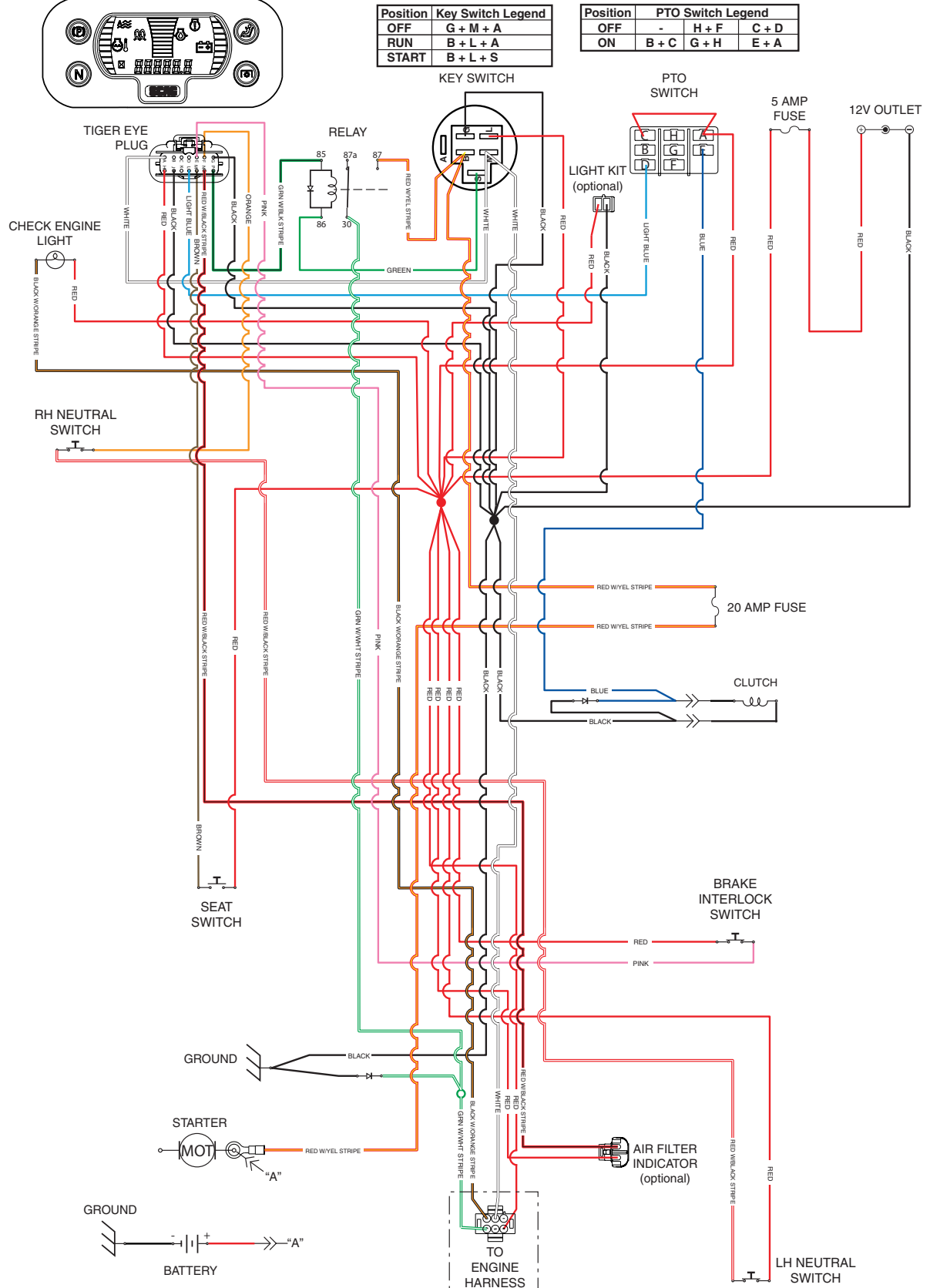

STCII KAWASAKI ENGINE ADAPTER ELECTRICAL SCHEMATIC

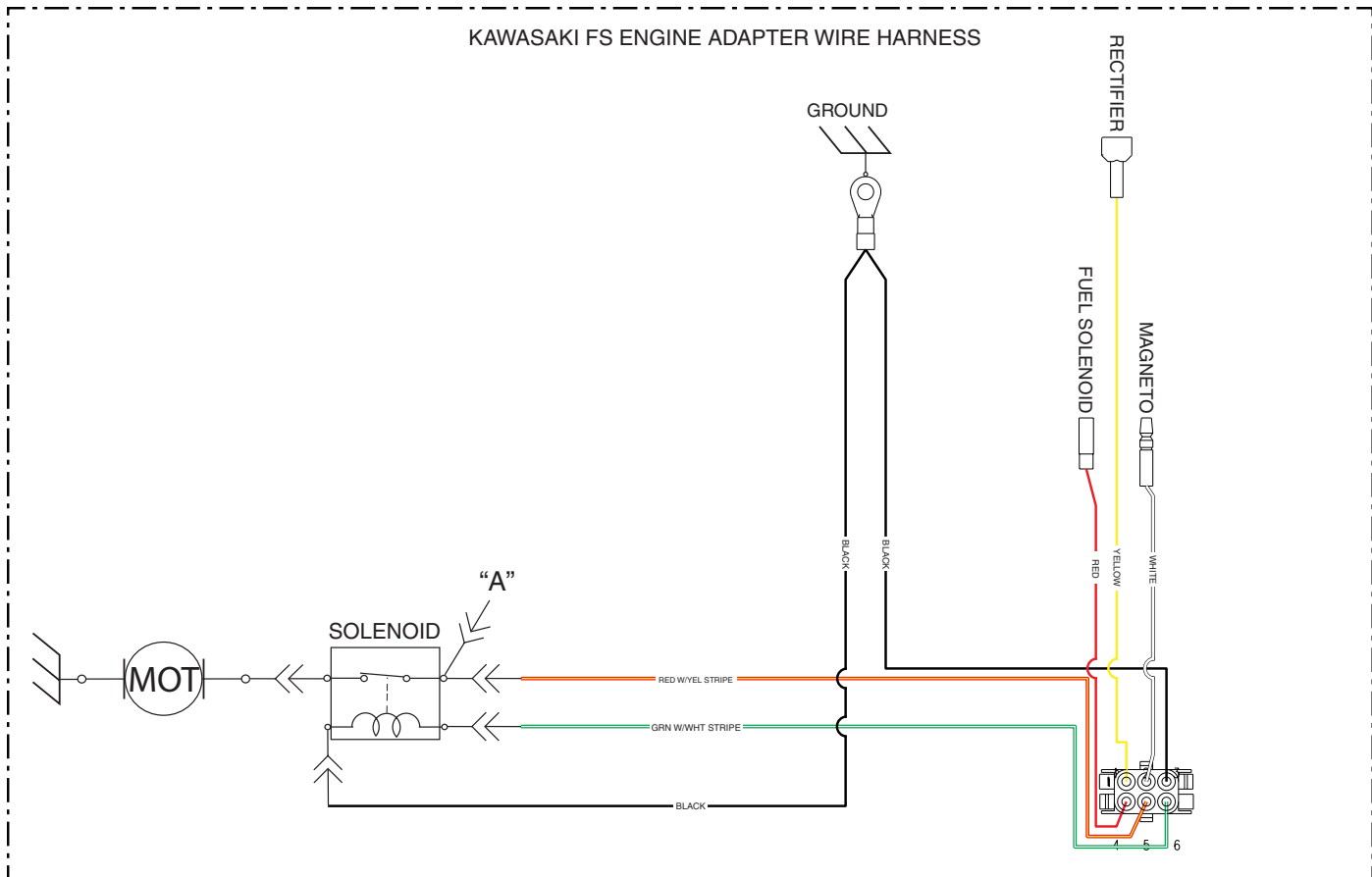
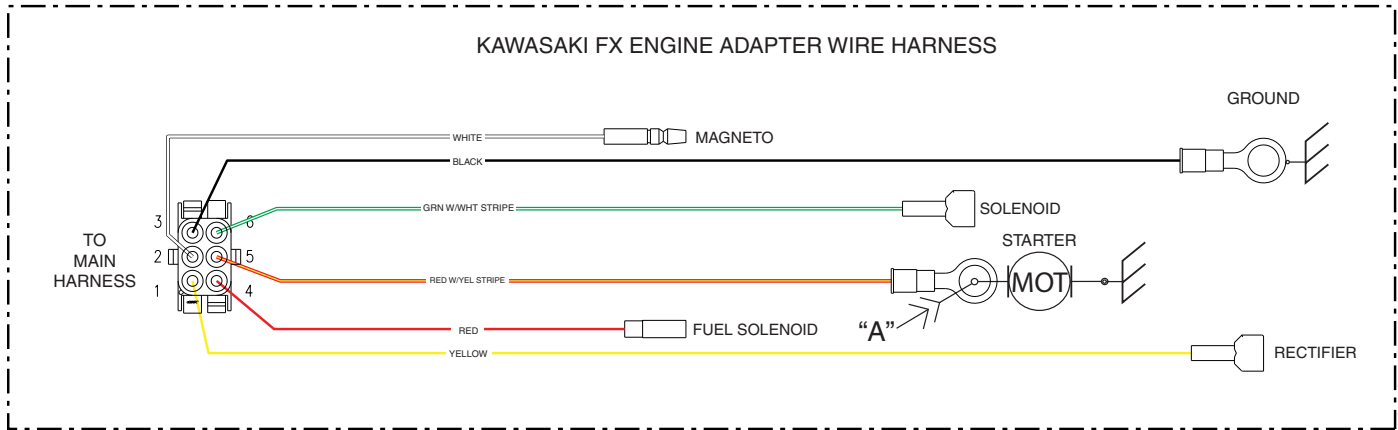

STCII KOHLER ENGINE ADAPTER ELECTRICAL SCHEMATIC

