

# SCAG<sup>®</sup>

## POWER EQUIPMENT

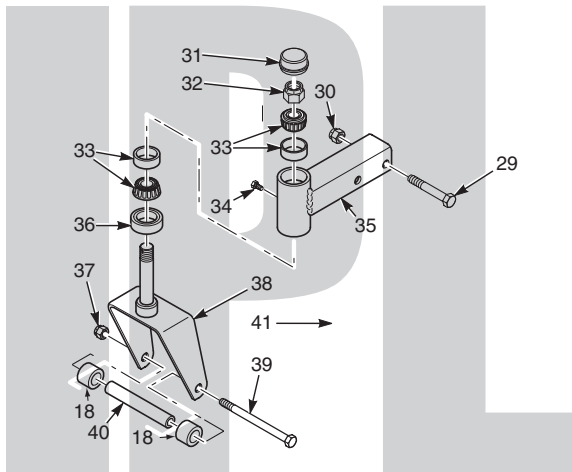

# ILLUSTRATED PARTS MANUAL



## Model STCII

### *TIGER CAT. II*

**THIS MANUAL CONTAINS THE ILLUSTRATED PARTS LIST FOR MODELS:**

**STCII-48V-22FX**  
**STCII-48V-26MX**  
**STCII-52V-25CV-EFI**  
**STCII-52V-26FT-EFI**  
**STCII-52V-27MX**  
**STCII-52V-28BV-EFI**  
**STCII-52V-29MX-EFI**  
**STCII-61V-26FT-EFI**  
**STCII-61V-27FX**  
**STCII-61V-31MX-EFI**  
**STCII-61V-32BV**

**with a serial number of S7400001 to S7499999**  
**with a serial number of T3700001 to T3799999**  
**with a serial number of S7500001 to S7599999**  
**with a serial number of S7600001 to S7699999**  
**with a serial number of T3800001 to T3899999**  
**with a serial number of S7700001 to S7799999**  
**with a serial number of T3900001 to T3999999**  
**with a serial number of S7800001 to S7899999**  
**with a serial number of S7900001 to S7999999**  
**with a serial number of T4000001 to T4099999**  
**with a serial number of S8000001 to S8099999**



## Table of Contents

SCAG APPROVED ATTACHMENTS AND ACCESSORIES.....	2
48V & 52V CUTTER DECKS .....	4
61V CUTTER DECK.....	6
CUTTER DECK CONTROLS .....	8
SHEET METAL COMPONENTS.....	10
STCII FOLDABLE ROLL-OVER PROTECTION SYSTEM.....	12
STCII SUSPENSION SEAT.....	14
DRIVE SYSTEM COMPONENTS .....	16
ENGINE & ATTACHING PARTS .....	18
STEERING COMPONENTS.....	20
BRAKE COMPONENTS .....	22
HYDRAULIC SYSTEM .....	24
STCII FUEL SYSTEM.....	26
ELECTRICAL SYSTEM .....	28
ELECTRICAL SYSTEM - KAWASAKI 26FT-EFI .....	30
ELECTRICAL SYSTEM - KOHLER EFI / YAMAHA EFI .....	32
STCII HYDRAULIC PUMP ASSEMBLY .....	34
REPLACEMENT DECALS AND INFORMATION PLATES.....	36
STCII - KAWASAKI FX / YAMAHA MX ELECTRICAL SCHEMATIC.....	38
STCII KAWASAKI FX ENGINE ADAPTER ELECTRICAL SCHEMATIC .....	39
STCII YAMAHA MX ENGINE ADAPTER ELECTRICAL SCHEMATIC .....	39
STCII - KAWASAKI 26FT EFI ELECTRICAL SCHEMATIC.....	40
STCII - KOHLER 25CV-EFI ELECTRICAL SCHEMATIC.....	41
STCII - BRIGGS & STRATTON 28BV-EFI / 32BV ELECTRICAL SCHEMATIC .....	41
STCII - YAMAHA MX-EFI ELECTRICAL SCHEMATIC.....	41
STCII BRIGGS & STRATTON 28BV-EFI ENGINE ADAPTER ELECTRICAL SCHEMATIC .....	42
STCII BRIGGS & STRATTON 32BV ENGINE ADAPTER ELECTRICAL SCHEMATIC .....	42

## ILLUSTRATED PARTS LIST

### 8.1 SCAG APPROVED ATTACHMENTS AND ACCESSORIES.

Attachments and accessories manufactured by companies other than Scag Power Equipment are not approved for use on this machine.

Scag approved attachments and accessories:

- GC-3B - 901S (Requires a 901E, 48V/52V Install Kit) or (901F, 61V STCII Install Kit)
- GC-CS - 901T (Requires a 901E, 48V/52V Install Kit) or (901F, 61V STCII Install Kit)
- Mulch Plate - 9286 (48V), 9287 (52V), 9288 (61V)
- Hurricane Mulch - 9283 (48V), 9284 (52V), 9285 (61V)
- STCII Hitch - 922C
- STCII LED Lights - 923W
- ODCD - 922Z (48V), 923A (52V), 923B (61V)
- Tiger Striper - 923G (Requires a 923H Install Kit)
- Blade Buddy - 9212
- Quick-Fit Controls - 9289
- Air Filter Indicator (922U) - Available for Kawasaki 22FX, Briggs & Stratton 32BV
- 12" Chrome Wheel Covers - 920J (set of 2)

Scag Premium Lubricants:

- Chassis Grease (p/n 486257)
- Spindle Grease (p/n 486258)
- 20W50 Oil - Gallon (p/n 486254)
- 20W50 Oil - Quart (p/n 486255)

**NOTES**

## 48V & 52V CUTTER DECKS

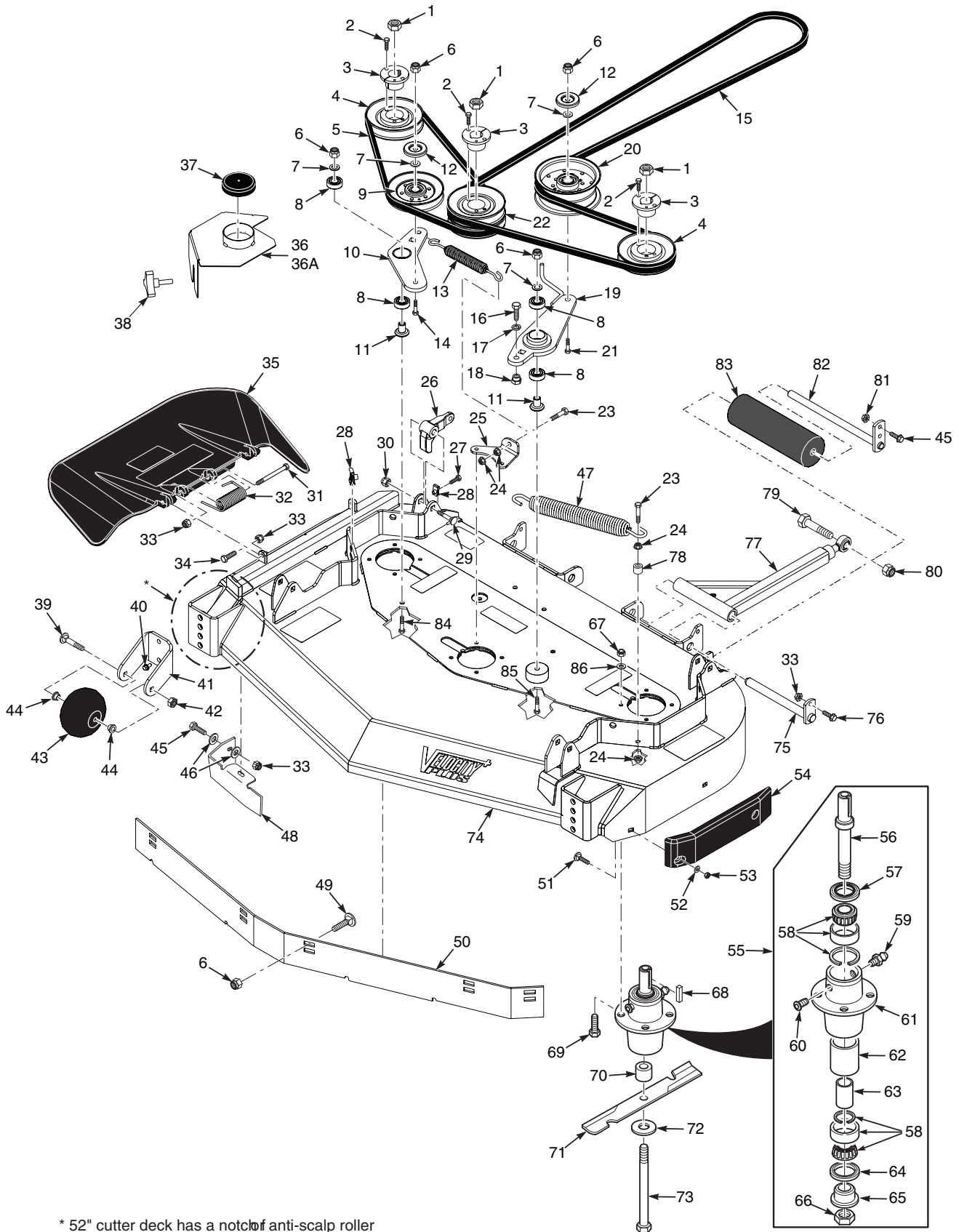

\* 52" cutter deck has a notch on anti-scalp roller

## 48V & 52V CUTTER DECKS

Ref. No.	Part No.	Description	48	52
1	04020-09	Nut, 5/8-11 UNC	X	X
2	04001-172	Bolt, Hex Head 1/4-20 x 1" Grade 8	X	X
3	48926	Hub, Tapered 1-1/8" Bore	X	X
4	483282	Pulley 4.75"	X	
	483284	Pulley 5.35"		X
5	483239	Belt, RH Cutter Deck	X	
	483240	Belt, RH Cutter Deck		X
6	04021-09	Nut, Elastic Stop 3/8-16	X	X
7	04043-04	Flatwasher, 3/8"	X	X
8	48224	Bearing	X	X
9	48181	Pulley, Idler 5" Dia.	X	X
10	461946	Idler Arm (Incl. #8)	X	X
11	43689	Idler Pivot	X	X
12	424367	Dust Shield	X	X
13	483247	Spring, Idler RH	X	X
14	04001-45	Bolt, Hex Head 3/8-16 x 2"	X	X
15	486283	Belt, Cutter Deck Drive (48V)	X	
	486284	Belt, Cutter Deck Drive (52V)		X
16	04001-27	Bolt, Hex Head 7/16-14 x 1"	X	X
17	04030-05	Lockwasher 7/16"	X	X
18	43686	Boss, Spring Anchor	X	X
19	462503	Idler Arm (Includes 8)	X	X
20	483210	Pulley, Idler 5" Dia.	X	X
21	04001-54	Bolt, Hex Head 3/8-16 x 3"	X	X
22	483283	Pulley, Double Groove	X	
	483285	Pulley, Double Groove		X
23	04001-136	Bolt, Hex Head 3/8-16 x 1-1/2" Gr. 8	X	X
24	04019-04	Nut, 3/8-16 Serrated Flange	X	X
25	424376	Bracket, Spring Anchor RH (48V)	X	
	424377	Bracket, Spring Anchor RH (52V)		X
26	485528	Lever, Deck Level	X	X
27	04107-04	Bolt, Hex Head 3/8-16 x 2" Spec	X	X
28	04110-03	U-Nut, 3/8-16	X	X
29	04003-42	Bolt, Carriage 7/16-14 x 2-1/4"	X	X
30	04021-11	Nut, Elastic Stop 7/16-14	X	X
31	04001-154	Bolt, Hex Head 5/16-18 x 4-3/4"	X	X
32	483378	Spring, Discharge Chute	X	X
33	04021-10	Nut, Elastic Stop 5/16-18	X	X
34	04001-12	Bolt, Hex Head 5/16-18 x 1-3/4"	X	X
35	461844	Discharge Chute Assy.	X	
	*462473	CA Discharge Chute, 48V	X	
	461845	Discharge Chute Assy.		X
	462475	CA Discharge Chute, 52V		X
36	462480	Belt Cover Weldment RH (incl. #37)	X	
	462822	Belt Cover Weldment LH (incl. #37)	X	
36A	462825	Belt Cover Weldment RH (incl. #37)		X
	462824	Belt Cover Weldment LH (incl. #37)		X
37	484368	Cap, Spindle	X	X
38	481625-01	Wing Nut, 3/8-16	X	X
39	04003-26	Bolt, Carriage 3/8-16 x 4"	X	X
40	04017-27	Bolt, Serrated Flange 3/8-16 x 1"	X	X
41	422478	Bracket, Anti-Scalp Wheel	X	X

Ref. No.	Part No.	Description	48	52
42	04021-05	Locknut, 3/8-16 Center Lock	X	X
43	481632	Anti-Scalp Wheel (INCL. #44)	X	X
44	48100-15	Bushing, .376 ID Oilite	X	X
45	04001-09	Bolt, Hex Head 5/16-18 x 1"	X	X
46	04040-15	Flatwasher, 5/16"	X	X
47	483246	Spring, Idler LH	X	X
48	424677	Turbo Baffle, Bolt On	X	X
	*425619	Turbo Baffle, 48V	X	
	*424211	Turbo Baffle, 52V		X
49	04003-23	Bolt, Carriage 3/8-16 x 1"	X	X
50	424839	Baffle Custom-Cut, 48V (7-Position)	X	
	424840	Baffle Custom-Cut, 52V (7-Position)		X
51	04003-12	Bolt, Carriage 5/16-18 x 3/4"	X	X
52	04040-04	Flatwasher, 5/16"	X	X
53	04021-04	Nut, Center Lock 5/16-18	X	X
54	483176	Wear Pad	X	X
55	461663	Spindle Assembly With Hardware	X	X
56	43589	Shaft, Spindle	X	X
57	481024	Seal Upper	X	X
58	481022	Bearing Assembly	X	X
59	48114-04	Grease Fitting	X	X
60	48677	Valve, Grease Relief	X	X
61	43644	Housing, Spindle	X	X
62	43312	Spacer, Outside	X	X
63	43296	Spacer, Inside	X	X
64	481025	Seal, Lower	X	X
65	43297	Bushing, Bottom	X	X
66	481035	Nut, Special 1-1/16 - 18	X	X
67	04021-22	Nut, Elastic Stop 5/16-18 Grade 8	X	X
68	04063-08	Key, 1/4 x 1/4 x 2"	X	X
69	04001-176	Bolt, Hex Head 5/16-18 x 1-3/4" Gr. 8	X	X
70	43590	Spacer, Spindle	X	X
71	482877	Cutter Blade 16.5"	X	
	482878	Cutter Blade 18"		X
72	04043-06	Flatwasher, 5/8" Hardened	X	X
73	04001-41	Bolt, Hex Head 5/8-11 x 9-1/2"	X	X
74	462867	Cutter Deck Velocity Plus	X	
	462868	Cutter Deck Velocity Plus		X
75	451240	Push Arm Shaft	X	X
76	04001-09	Bolt, Hex Head 5/16-18 x 1"	X	X
77	461516	Push Arm Assembly	X	X
78	43063	Spacer	X	X
79	04001-79	Bolt, Hex Head 5/8-11 x 4-1/2"	X	X
80	04021-13	Nut, Elastic Stop 5/8-11	X	X
81	04117-01	Locknut, 5/16-18 Flange Hex Head	X	X
82	45944	Shaft, Roller	X	X
83	48038	Roller, Rear	X	X
84	04001-46	Bolt, Hex Head 3/8-16 x 2-1/4"	X	X
85	04001-62	Bolt, Hex Head 3/8-16 x 3-1/4"	X	X
86	04030-03	Lockwasher 5/16"	X	X

\* = California Models Only (not shown)

## 61V CUTTER DECK

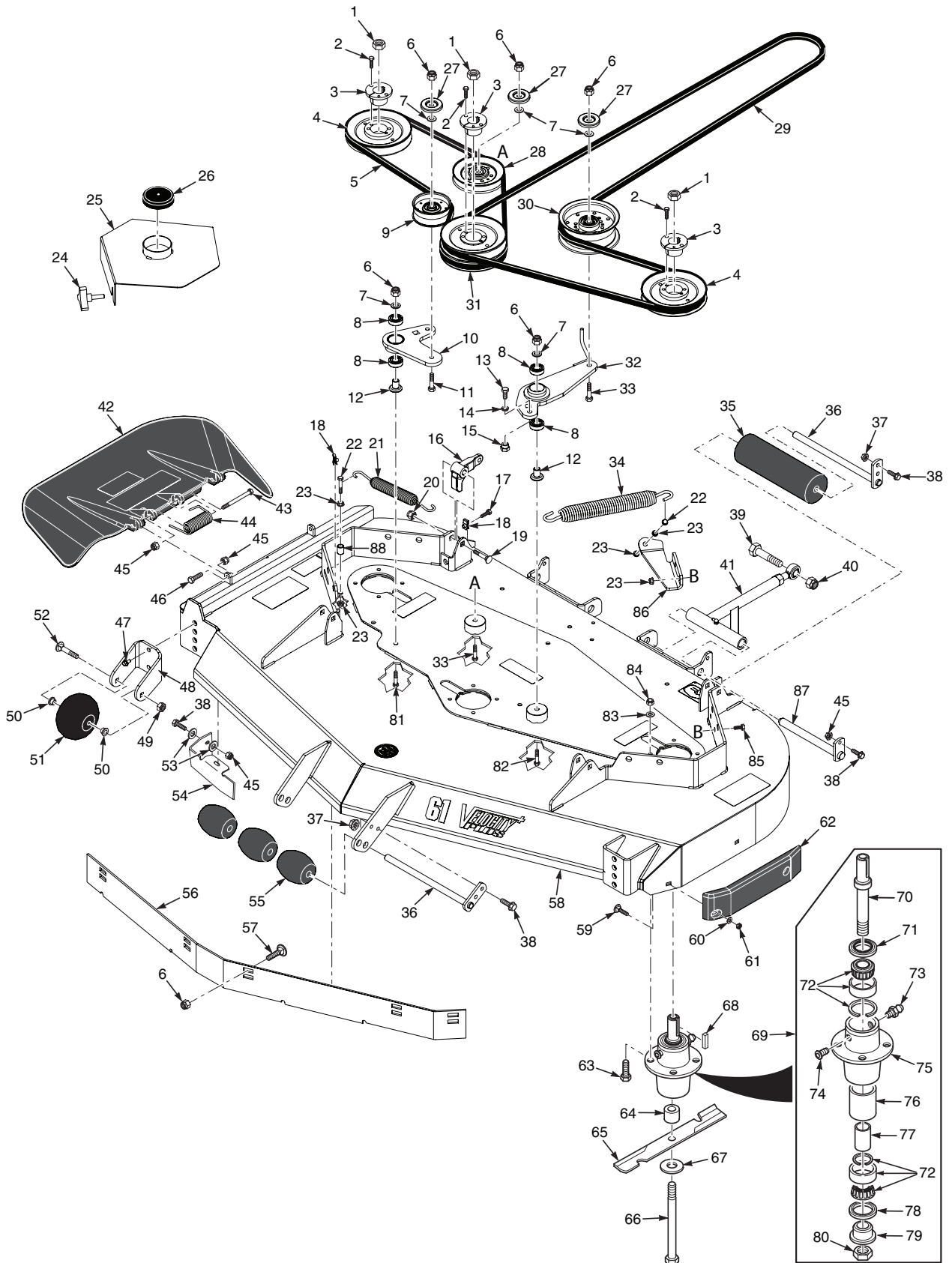



## 61V CUTTER DECK

Ref. No.	Part No.	Description
1	04020-09	Nut, 5/8-11 UNC
2	04001-172	Bolt, Hex Head 1/4-20 x 1" Grade 8
3	48926	Hub, Tapered 1-1/8" Bore
4	483286	Pulley, Tapered Bore 6.33" Dia.
5	483157	Belt, Deck Drive RH
6	04021-09	Nut, Elastic Stop 3/8-16
7	04043-04	Flatwasher, 3/8" - .938 x .391 x .105"
8	48224	Bearing
9	486045	Idler Pulley, 3-1/2" Dia.
10	462888	Idler Arm (Incl. #8)
11	04001-31	Bolt, Hex Head 3/8-16 x 2-1/2"
12	43689	Pivot, Idler Arm
13	04001-27	Bolt, Hex Head 7/16-14 x 1"
14	04030-05	Lockwasher 7/16"
15	43686	Boss, Spring Anchor
16	485528	Lever, Deck Level
17	04107-04	Bolt, Hex Head 3/8-16 x 2" Spec
18	04110-03	U-Nut, 3/8-16
19	04003-42	Bolt, Carriage 7/16-14 x 2-1/4"
20	04021-11	Nut, Elastic Stop 7/16-14
21	483703	Spring, RH Deck Drive
22	04001-136	Bolt, Hex Head 3/8-16 x 1-1/2" Gr.8
23	04019-04	Nut, Serrated Flange 3/8-16
24	481625-01	Wing Nut, 3/8-16
25	462818	Belt Cover Weldment (incl. #26)
26	484368	Cap, Spindle
27	424367	Dust Shield
28	48181	Idler Pulley, 5" Dia.
29	485845	Belt, Deck Drive 61V
30	483210	Idler Pulley, 5" Dia.
31	483287	Pulley, Double Groove 6.33" Dia.
32	462269	Idler Arm (Incl. #8)
33	04001-54	Bolt, Hex Head 3/8-16 x 3"
34	483246	Spring, LH Deck Drive
35	48038	Roller, Rear
36	45944	Shaft, Roller
37	04117-01	Locknut, 5/16-18 Flange Hex Head
38	04001-09	Bolt, Hex Head 5/16-18 x 1"
39	04001-79	Bolt, Hex Head 5/8-11 x 4-1/2"
40	04021-13	Nut, Elastic Stop 5/8-11
41	461516	Push Arm Assembly
42	461846	Discharge Chute Assy.
	*462477	CA Discharge Chute Assy.
43	04001-154	Bolt, Hex Head 5/16-18 x 4-3/4"

Ref. No.	Part No.	Description
44	483378	Spring, Discharge Chute
45	04021-10	Nut, Elastic Stop 5/16-18
46	04001-12	Hex Head 5/16-18 x 1-3/4"
47	04017-27	Bolt, Serrated Flange 3/8-16 x 1"
48	422478	Bracket, Anti-Scalp Wheel
49	04021-05	Locknut, 3/8-16 Center Lock
50	48100-15	Bushing, .376 ID Oilite
51	481632	Anti-Scalp Wheel
52	04003-26	Bolt, Carriage 3/8-16 x 4"
53	04040-15	Flatwasher 5/16"
54	424209	Turbo Baffle, Bolt On
	*425625	Turbo Baffle 61V
55	482295	Wheel, Anti Scalp
56	424841	Baffle Custom-Cut, 61V (7-Position)
57	04003-23	Bolt, Carriage 3/8-16 x 1"
58	462869	Cutter Deck Velocity Plus
59	04003-12	Bolt, Carr. 5/16-18 x 3/4"
60	04040-04	Flatwasher, 5/16-.344 x .688 x .065"
61	04021-04	Nut, Center Lock 5/16"
62	483176	Wear Pad
63	04001-176	Bolt, Hex Head 5/16-18 x 1-3/4" Grade 8
64	43590	Spacer, Spindle
65	482879	Cutter Blade 21"
66	04001-41	Bolt, Hex Head 5/8-11 x 9-1/2"
67	04043-06	Flatwasher, 5/8" Hardened
68	04063-08	Key, 1/4 x 1/4 x 2"
69	461663	Spindle Assembly With Hardware
70	43589	Shaft, Spindle
71	481024	Seal Upper
72	481022	Bearing Assembly
73	48114-04	Grease Fitting
74	48677	Valve, Grease Relief
75	43644	Housing, Spindle
76	43312	Spacer, Outside
77	43296	Spacer, Inside
78	481025	Seal, Lower
79	43297	Seal, Lower
80	481035	Nut, Special 1-1/16 - 18
81	04001-46	Bolt, Hex Head 3/8-16 x 2-1/4"
82	04001-62	Bolt, Hex Head 3/8-16 x 3-1/4"
83	04030-03	Lockwasher 5/16"
84	04021-22	Nut, Elastic Stop 5/16-18 Grade 8
85	04001-19	Bolt, Hex Head 3/8-16 x 1"
86	427023	Bracket, Spring Anchor
87	451240	Push Arm Shaft
88	43063	Spacer

\* = California Models Only (not shown)

## CUTTER DECK CONTROLS

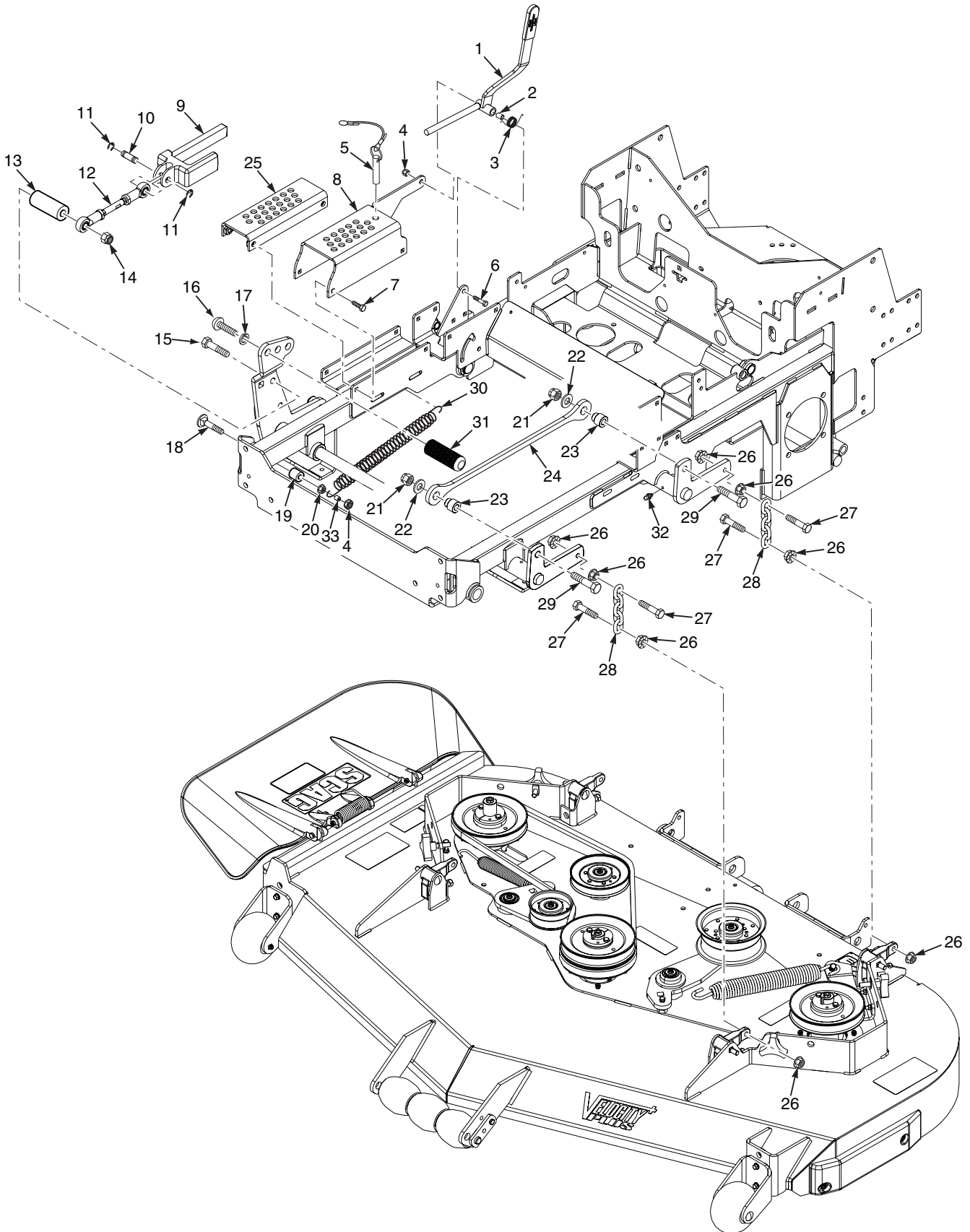

## CUTTER DECK CONTROLS

Ref. No.	Part No.	Description
1	462839	Deck Latch Assembly (Includes Grip)
	485592	Grip, Deck Latch
2	43874	Spacer, Deck Latch
3	485704	Spring, Torsion - Lever Return
4	04021-05	Nut, Center Lock 3/8-16
5	483345	Pin Assembly, w/Lanyard
6	04001-31	Bolt, Hex Head 3/8-16 x 2-1/2"
7	04006-02	Bolt, Hex Wshr Head 5/16-18 x 1-1/4"
8	425737	Adjustment Bracket, Cutting Height
9	462872	Slide, Height Adjust (INCL. 10,11,12)
10	43487	Pin, Deck Lift
11	04050-18	Retaining Ring, 1/2" Ext.
12	482534	Linkage Assembly, Deck Lift
13	43873	Spacer, Deck Lift Pedal
14	04021-07	Nut, Elastic Stop 1/2-13
15	04001-87	Bolt, Hex Head 1/2-13 x 4"
16	04108-04	Capscrew, 5/8-11 x 1-1/2"
17	04030-07	Lockwasher, 5/8" Spring
18	04003-21	Bolt, Carriage 3/8-16 x 2-1/2"
19	43572	Spacer
20	04019-04	Nut, Serrated Flange 3/8-16
21	04021-07	Nut, Elastic Stop 1/2-13
22	04040-13	Flatwasher, 1/2-.562 x 1.375 x .109
23	431018	Pivot, Deck Link
24	428513	Link, Decklift (black)
25	452408	Adjustment Bracket, Lower Cut Height
26	04019-04	Nut, Serrated Flange 3/8-16
27	04001-20	Bolt, Hex Head 3/8-16 x 1-1/2"
28	482628	Chain
29	04001-153	Bolt, Hex Head 1/2-13 x 2-1/4"
30	483177	Spring, Decklift
31	424504	Foot Pedal, Height Adjustment
32	48114-04	Grease Fitting
33	43212	Spacer, Deck Assist
*	04059-01	Deck Height Stop

\* = Item Not Shown

## SHEET METAL COMPONENTS

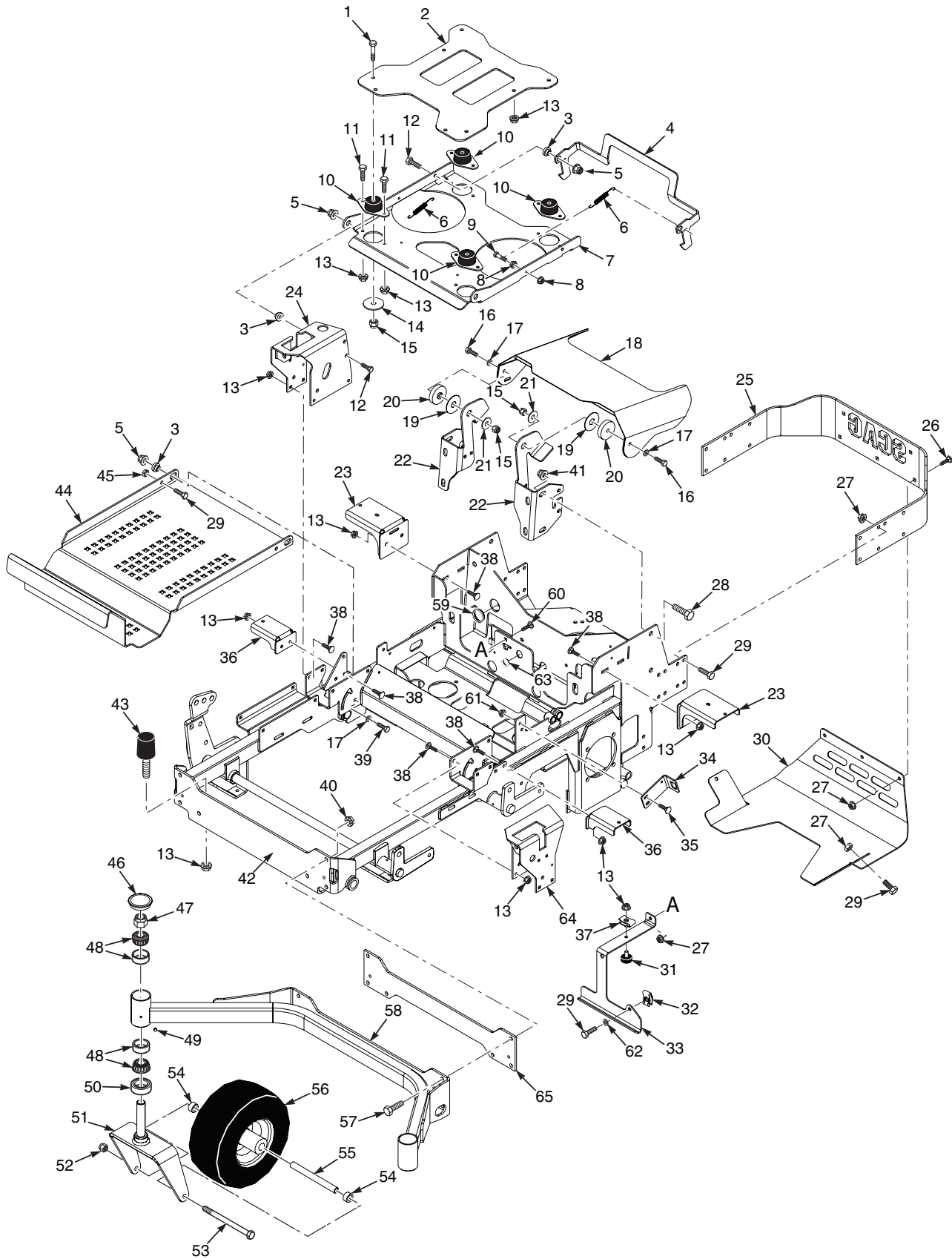

## SHEET METAL COMPONENTS

Ref. No.	Part No.	Description
1	04001-46	Bolt, Hex Head 3/8-16 x 2-1/4"
2	462863	Seat Plate w/decal
3	43086	Bushing
4	426949	Seat Latch
5	04117-02	Nut, Elastic Flange 3/8-16
6	484498	Spring, Seat Latch
7	463106	Plate, Seat Mounting w/decals
8	04019-02	Nut, Serrated Flange 1/4-20
9	04001-59	Bolt, Hex Head 1/4-20 x 1-1/4"
10	484148	Isolator, Seat
11	04001-08	Bolt, Hex Head 5/16-18 x 3/4"
12	04001-32	Bolt, Hex Head 3/8-16 x 1-1/4"
13	04019-03	Nut, Hex Serr. Flng 5/16-18
14	04041-38	Flatwasher, 3/8-.406 x 2.25 x .1875
15	04021-09	Nut, Elastic Stop 3/8-16
16	04001-21	Bolt, Hex Head 3/8-16 x 1-3/4"
17	04041-07	Flatwasher, 3/8-.391 x .938 x .105
18	462838	Hood Assembly
19	483471	Disk, Anti-Friction
20	43740	Spacer, Hood
21	04041-11	Flatwasher, 3/8-.406 x 1.50 x 7 Ga.
22	427029	ROPS Mount, RH
	427178	ROPS Mount, RH, 32BV
	427028	ROPS Mount, LH
	427177	ROPS Mount, LH, 32BV
23	427063	Mounting Bracket, Fuel Tank Rear
24	463326	Control Plate w/decal, RH (black)
25	425725	Bumper, Rear
26	04003-23	Bolt, Carriage 3/8-16 x 1"
27	04019-04	Nut, 3/8-16 Serr. Flange
28	04001-70	Bolt, Hex Head 1/2-13 x 1-1/4"
29	04001-19	Bolt, Hex Head 3/8-16 x 1"
30	427032	Plate, Skid
31	481284	Bumper, Rubber

Ref. No.	Part No.	Description
32	04110-03	U-Nut, 3/8-16
33	427334	Battery Hold Down
34	425905	Mounting Bracket, Neutral Switch
35	04003-02	Bolt, Carriage 1/4-20 x 3/4"
36	425862	Mounting Bracket, Fuel Tank Front
37	48030-18	Clamp, Cable 1" Double
38	04003-12	Bolt, Carriage 5/16-18 x 3/4"
39	04001-20	Bolt, Hex Head 3/8-16 x 1-1/2"
40	04117-05	Nut, 7/16-14 Flange Elastic Stop
41	04117-04	Nut, 1/2-13 Flange Elastic Stop
42	462921	Main Frame Assembly w/decals (INCL. 24)
43	485663	Rubber Isolator
44	426931	Footplate
45	04020-12	Nut, Jam 3/8-16
46	484195	Cap, Grease
47	04021-20	Nut, Elastic Stop 1.0"-14
48	48668	Bearing Set
49	482028-01	Plug, 1/4-28
50	481025	Seal, 2.0" OD x 1.625" ID
51	453007	Yoke, Front Caster Wheel (black)
52	04021-07	Nut, Hex Elastic Stop 1/2-13
53	04001-167	Bolt, Hex Head 1/2-13 x 9-1/2"
54	43584	Spacer, Caster Wheel
55	43583	Sleeve
56	9278	Caster Wheel Assembly
57	04001-28	Bolt, Hex Head 7/16-14 x 1-1/4"
	04001-58	Bolt, Hex Head 7/16-14 x 1-1/2"
58	452284	Caster Support Weldment (48"/52")
	452727	Caster Support Weldment (61")
59	484617	Bushing, Thick Panel Snap
60	04003-31	Bolt, Carriage, 3/8-16 x 3/4"
61	04021-08	Nut, Lock, 1/4-20
62	04030-04	Washer, Lock 3/8 Spring
63	486019	Bushing, Thick Panel Snap - 1"
64	463325	Control Plate w/decal, LH (black)
65	428824	Weight, Caster - Yamaha Models Only

## STCII FOLDABLE ROLL-OVER PROTECTION SYSTEM

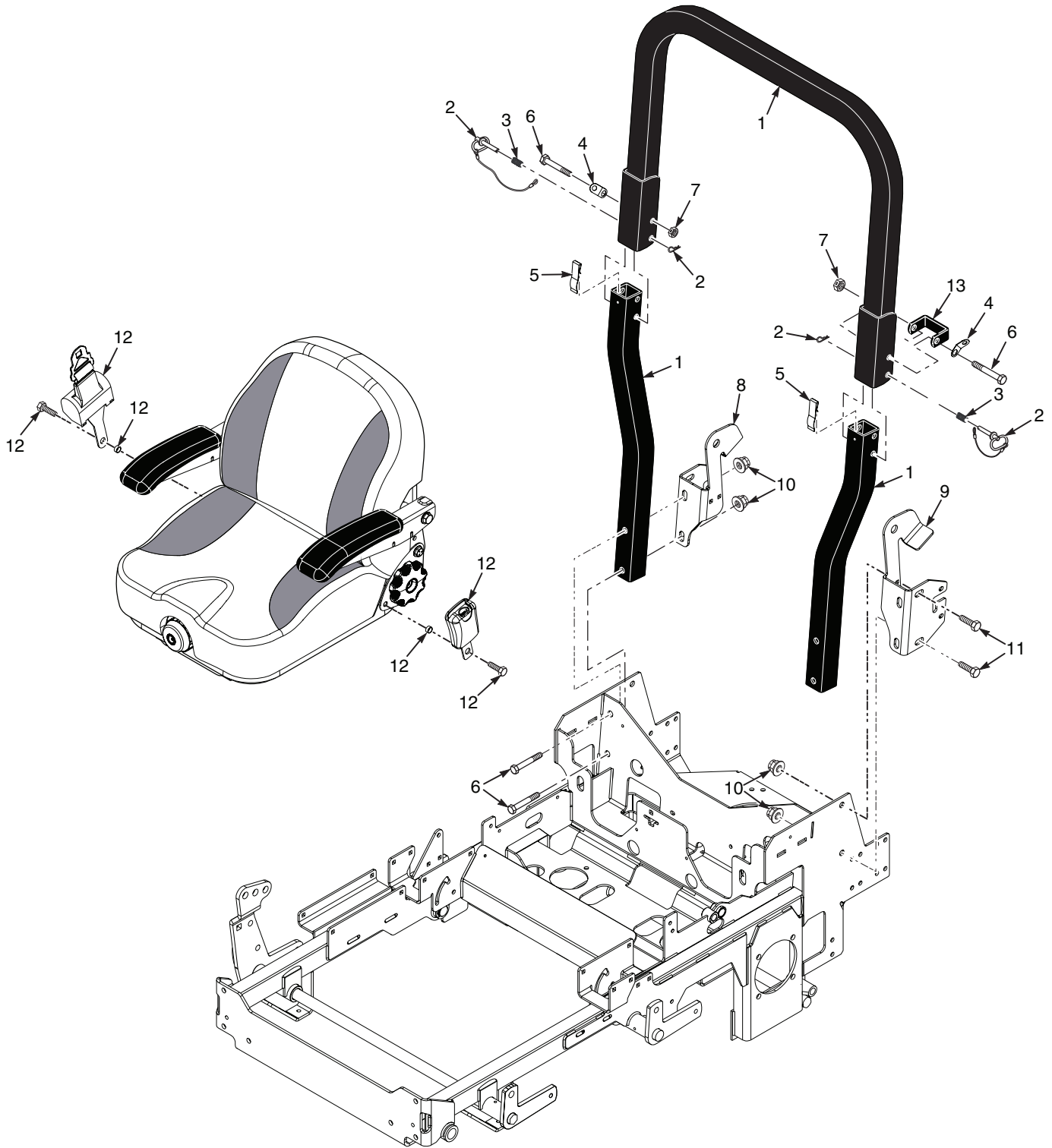

**STCII FOLDABLE ROLL-OVER PROTECTION SYSTEM**

<b>Ref. No.</b>	<b>Part No.</b>	<b>Description</b>
1	462414	ROPS Assembly, Foldable Without Stop
	462935	ROPS Assembly, Foldable With Stop
2	484168	Pin Assembly (incl. #3)
3	484170	Spring, ROPS
4	484169	Clip, ROPS
5	484167	Spring, ROPS Anti-Rattle
6	04001-90	Bolt, Hex Head 1/2-13 x 3-1/4"
7	04021-19	Nut, Center Lock 1/2-13
8	427029	ROPS Mount, RH, 22FX / 26FT-EFI / 25CV-EFI
	428575	ROPS Mount, RH, 27FX / 28BV-EFI / 32BV
9	427028	ROPS Mount, LH, 22FX / 26FT-EFI / 25CV-EFI
	428574	ROPS Mount, LH, 27FX / 28BV-EFI / 32BV
10	04117-04	Nut, 1/2-13 Flange Elastic Stop
11	04001-70	Bolt, Hex Head 1/2-13 x 1-1/4"
12	484717	Seat Belt Kit (Suspension Seat)
	484527	Seat Belt Kit (Soft Ride Seat)
13	427355	Stop, ROPS, 26FT / 32BV

## STCII SUSPENSION SEAT

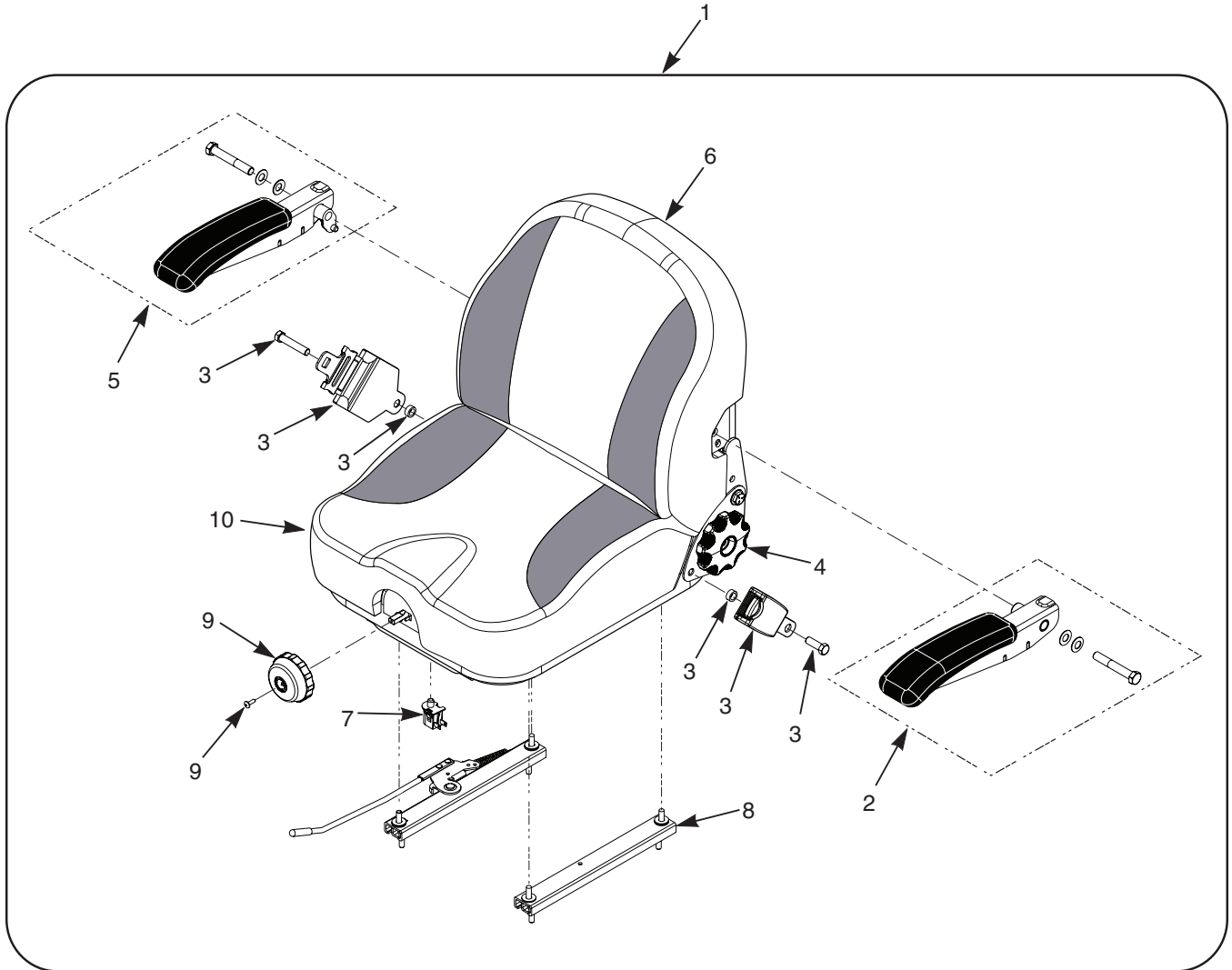



**STCII SUSPENSION SEAT**

<b>Ref. No.</b>	<b>Part No.</b>	<b>Description</b>
1	486591	Suspension Seat Assembly w/seat belt
2	484709	Armrest Kit, LH
3	484717	Seat Belt Kit
4	485652	Recliner Knob Kit
5	484710	Armrest Kit, RH
6	486596	Cover, Back Cushion
7	481638	Seat Switch
8	485594	Track Kit, (Includes Handle Kit p/n 485717)
9	484714	Suspension Knob Kit
10	486597	Cover, Seat Cushion
*	484719	Bellows (Track Cover)

\* = Item Not Shown

## DRIVE SYSTEM COMPONENTS

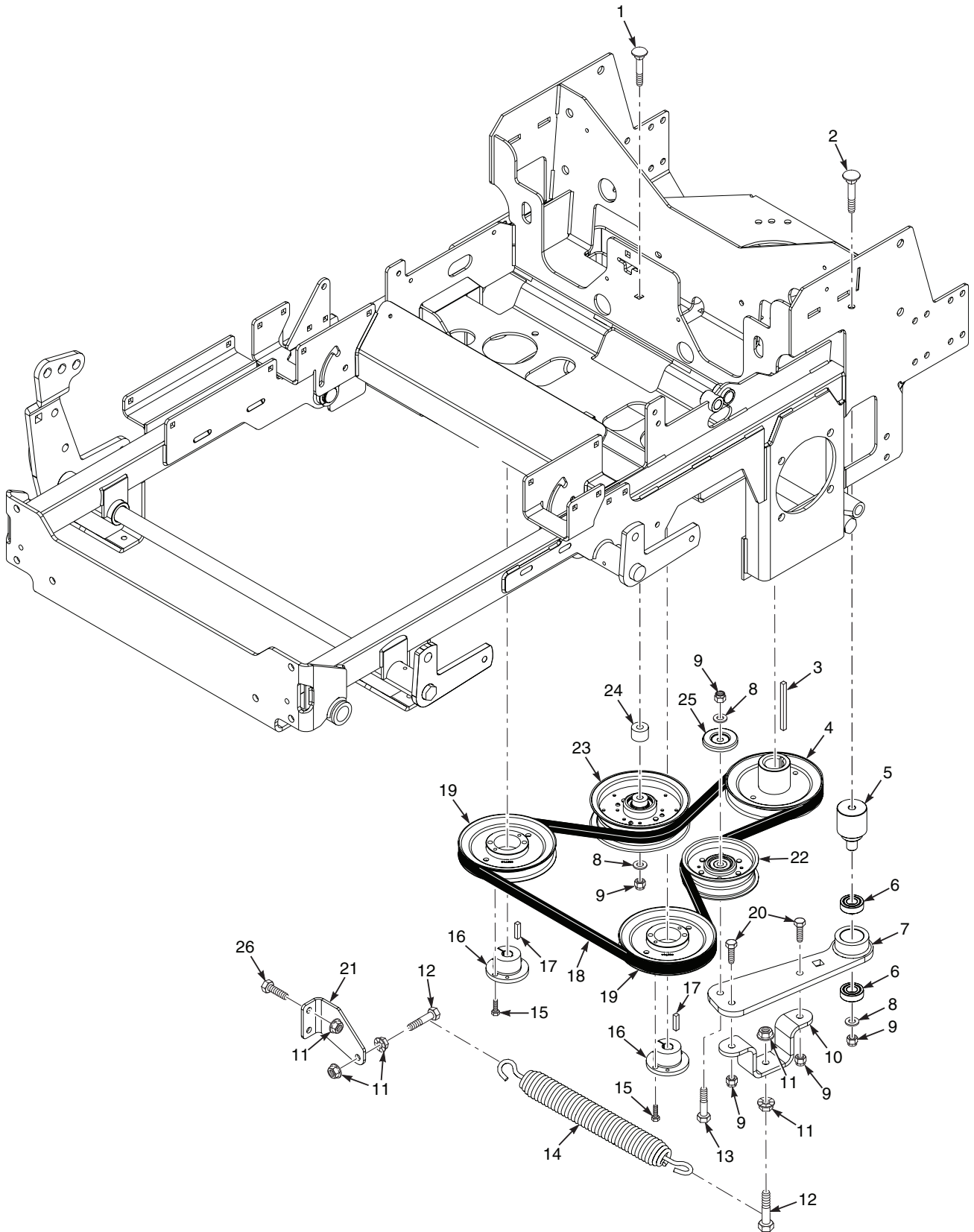

## DRIVE SYSTEM COMPONENTS

Ref. No.	Part No.	Description
1	04003-47	Bolt, Carriage 3/8-16 x 3-1/4"
2	04003-26	Bolt, Carriage 3/8-16 x 4"
3	04063-28	Key, 1/4 x 1/4 x 3-1/2"
4	485589	Pulley, 5.75" Dia. - 1.125 Bore
5	431025	Pivot, Idler Arm
6	48224	Bearing
7	462860	Idler Arm Assembly (incl. #6)
8	04043-04	Flatwasher, 3/8-.391 x .938 x .105 HD
9	04021-09	Nut, Elastic Stop 3/8-16
10	425386	Mounting Bracket, Idler
11	04019-04	Nut, Serrated Flange 3/8-16
12	04001-136	Bolt, Hex Head 3/8-16 x 1-1/2" Grade 8
13	04001-46	Bolt, Hex Head 3/8-16 x 2-1/4"
14	484202	Spring, Pump Drive
15	04001-172	Bolt, Hex Head 1/4-20 x 1"
16	482085	Hub, Tapered, 15mm Bore
17	04063-14	Key, 5 x 5 x 25mm
18	485649	Belt, Pump Drive
19	482744	Pulley, 5.75" OD Taper Bore
20	04001-32	Bolt, Hex Head 3/8-16 x 1-1/4"
21	427016	Bracket, Spring Anchor
22	484128	Pulley, 4" Dia. Idler
23	483215	Pulley, 5" Dia. Idler
24	43286	Spacer
25	424367	Dust Shield
26	04003-23	Bolt, Carriage 3/8-16 x 1"

## ENGINE & ATTACHING PARTS

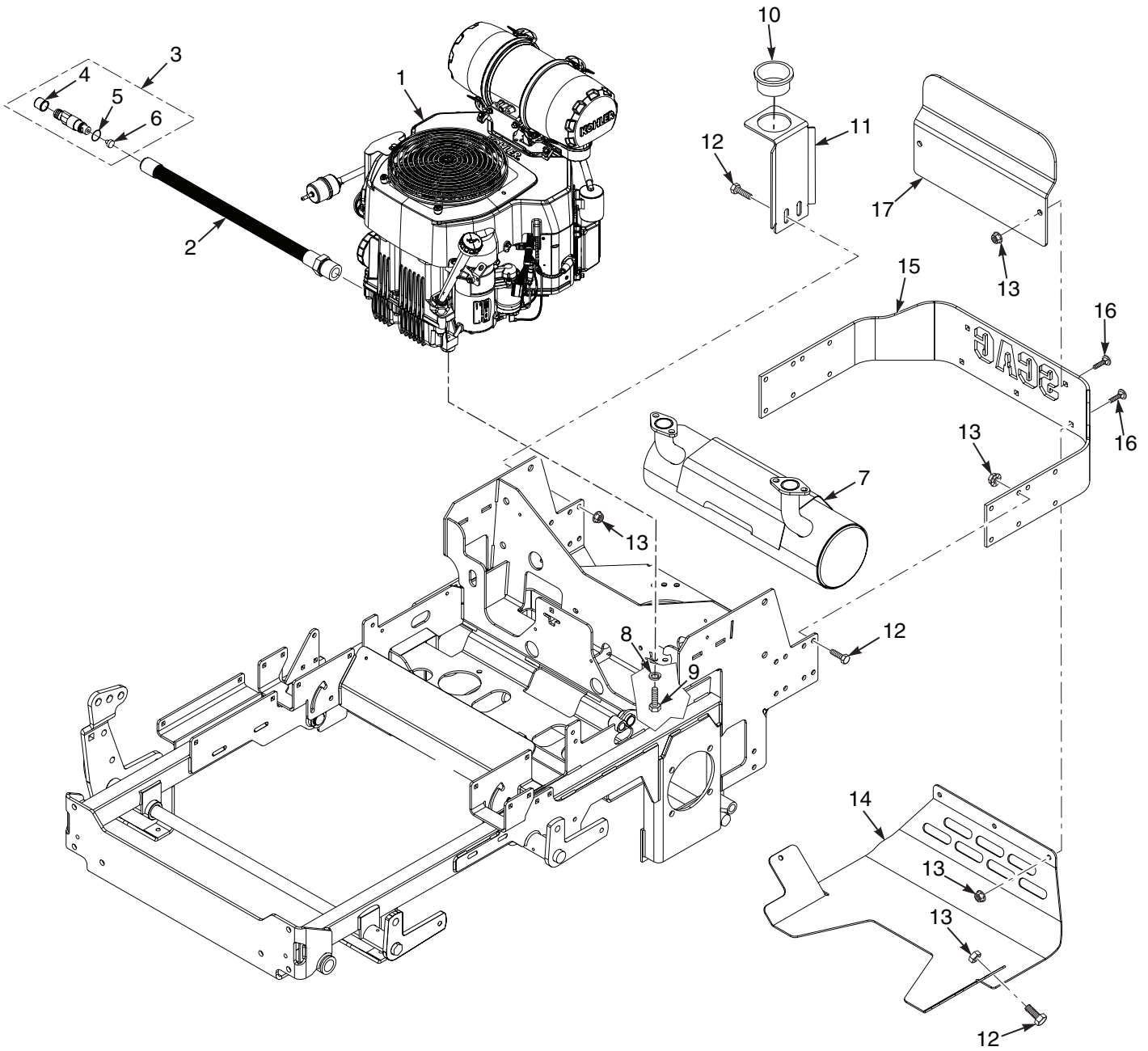

## ENGINE & ATTACHING PARTS

Ref. No.	Part No.	Description
1	*485020	Engine, Kawasaki 22FX
	*487059	Engine, Yamaha MX800V
	*486149	Engine, Kawasaki 26FT-EFI
	*487060	Engine, Yamaha MX825V
	*485032	Engine, Kawasaki 27FX
	*485728	Engine, Kohler 25CV-EFI
	*485978	Engine, Briggs and Stratton 28BV-EFI
	*487061	Engine, Yamaha MX775-EFI
	*487062	Engine, Yamaha MX800V-EFI
2	*486585	Engine, Briggs and Stratton 32BV
	484581	Hose, Oil Drain - Kawasaki FX (incl. #3, 4, 5, 6)
	484706	Hose, Oil Drain - Kohler CV-EFI (incl. #3, 4, 5, 6)
	484599	Hose, Oil Drain - Briggs and Stratton 32BV (incl. #3, 4, 5, 6)
3	484583	Valve Assembly, Oil Drain
4	484585	Cap
5	48603-12	O-Ring
6	484586	Seal
7	485705	Muffler, Kawasaki 22FX & FT-EFI
	486949	Muffler, Kawasaki 27FX
	484650	Muffler, Kohler 25CV-EFI
	486941	Muffler, Briggs and Stratton 28BV-EFI
	486579	Muffler, Briggs and Stratton 32BV
	*	Muffler, Yamaha
8	*	Muffler, Yamaha-EFI
	04030-04	Lockwasher, 3/8" Spring, Kawasaki FX / FT-EFI / B&S 32BV / Yamaha MX
9	04001-32	Bolt, Hex Head 3/8-16 x 1-1/4", Kawasaki FX / FT-EFI / Yamaha MX
	04011-07	Bolt, Hex Head 3/8-16 x 1-1/4" Self Tap, Kohler CV-EFI / B&S 28BV-EFI
	04001-20	Bolt, Hex Head 3/8-16 x 1-1/2" B&S 32BV
	04134-03	Nut, Top Lock w/ Flange, 3/8-16
	484617	Bushing, Thick Panel Snap
10	426040	Bracket, Oil Drain Hose
11	04001-19	Bolt, Hex Head 3/8-16 x 1"
12	04019-04	Nut, Serrated Flange 3/8-16
13	427032	Plate, Skid
14	425725	Bumper, Rear
15	04003-23	Bolt, Carriage 3/8-16 x 1"
16	425926	Guard, Engine
17	04002-06	Bolt, Hex Head M8 - 1.25 x 16 (Engine Ground) FX / FT-EFI
**	04031-03	Lockwasher, 5/16 Ext Tooth (Engine Ground) FX / FT-EFI
**	04017-05	Bolt, Hex Head Serrated Flange 1/4-20 (Engine Ground) 25CV-EFI
**	04019-02	Nut, Serrated Flange 1/4-20 (Engine Ground) 25CV-EFI
**	04011-14	Screw, 1/4-20 x 3/4" Taptite (Engine Ground) B&S 28BV-EFI
**	04031-03	Lockwasher, 5/16 Ext Tooth (Engine Ground) B&S 28BV-EFI & 32BV
**	04001-08	Bolt, Hex Head 5/16-18 x 3/4" (Engine Ground) Yamaha MX
**	04031-03	Lockwasher, 5/16 Ext Tooth (Engine Ground) Yamaha MX

\* = Not available through Scag.

\*\* = Not Shown

## STEERING COMPONENTS

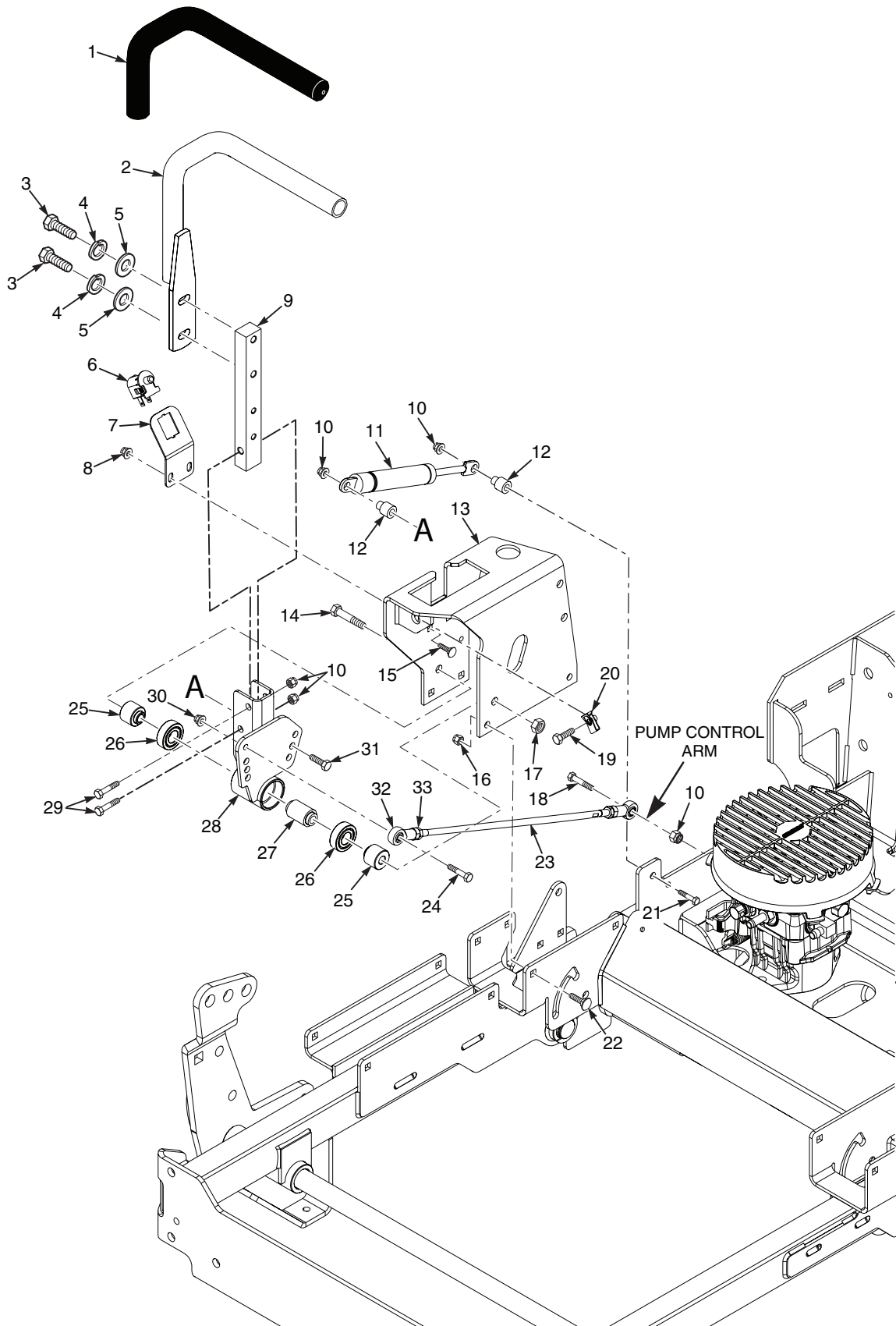

## STEERING COMPONENTS

Ref. No.	Part No.	Description
1	484376	Grip, Control Handle
2	462401	Handle Bar w/Grip
3	04001-32	Bolt, Hex Head 3/8-16 x 1-1/4"
4	04030-04	Lockwasher, 3/8" Spring
5	04041-07	Flatwasher, 3/8-.391 x .938 x .105
6	481638	Switch, N/O
7	425905	Bracket, Operator Presence Switch
8	04117-03	Nut, Flanged Elastic Stop 1/4-20
9	422372	Bar, Control Lever
10	04021-10	Nut, Elastic Stop 5/16-18
11	484151	Gas Damper
12	43602	Spacer, Pump Dampener
13	463325	Control Plate w/decal, LH
	463326	Control Plate w/decal, RH
14	04001-152	Bolt, Hex Head 3/8-16 x 4-1/4"
15	04003-02	Bolt, Carriage 1/4-20 x 3/4"
16	04019-03	Nut, Serrated Flange 5/16-18
17	04021-05	Nut, Center Lock 3/8-16
18	04001-09	Bolt, Hex Head 5/16-18 x 1"
19	04107-03	Bolt, Hex Head 3/8-16 x 1-1/4" with Thread Lock Patch
20	04110-03	U-Nut, 3/8-16
21	04001-11	Bolt, Hex Head 5/16-18 x 1-1/2", RH
	04001-12	Bolt, Hex Head 5/16-18 x 1-3/4", LH
22	04003-12	Bolt, Carriage 5/16-18 x 3/4"
23	485583	Linkage Assy, Steering (INCL. 32,33)
	484073	Rod End, 5/16-24 LH
	04020-31	Nut, 5/16-24 UNF Jam
24	04001-04	Bolt, Hex Head 1/4-20 x 1-1/2"
25	43607	Spacer, Controls
26	48224	Bearing
27	43600	Spacer, Bearing
28	453204	Pivot Weldment, Control Arm RH
	453203	Pivot Weldment, Control Arm LH
29	04001-12	Bolt, Hex Head 5/16-18 x 1-3/4"
30	04021-08	Nut, Elastic Stop 1/4-20
31	04001-11	Bolt, Hex Head 5/16-18 x 1-1/2"
32	485584	Rod End, 5/16-24 RH
33	04020-30	Nut, 5/16-24 UNF LH Jam

## BRAKE COMPONENTS

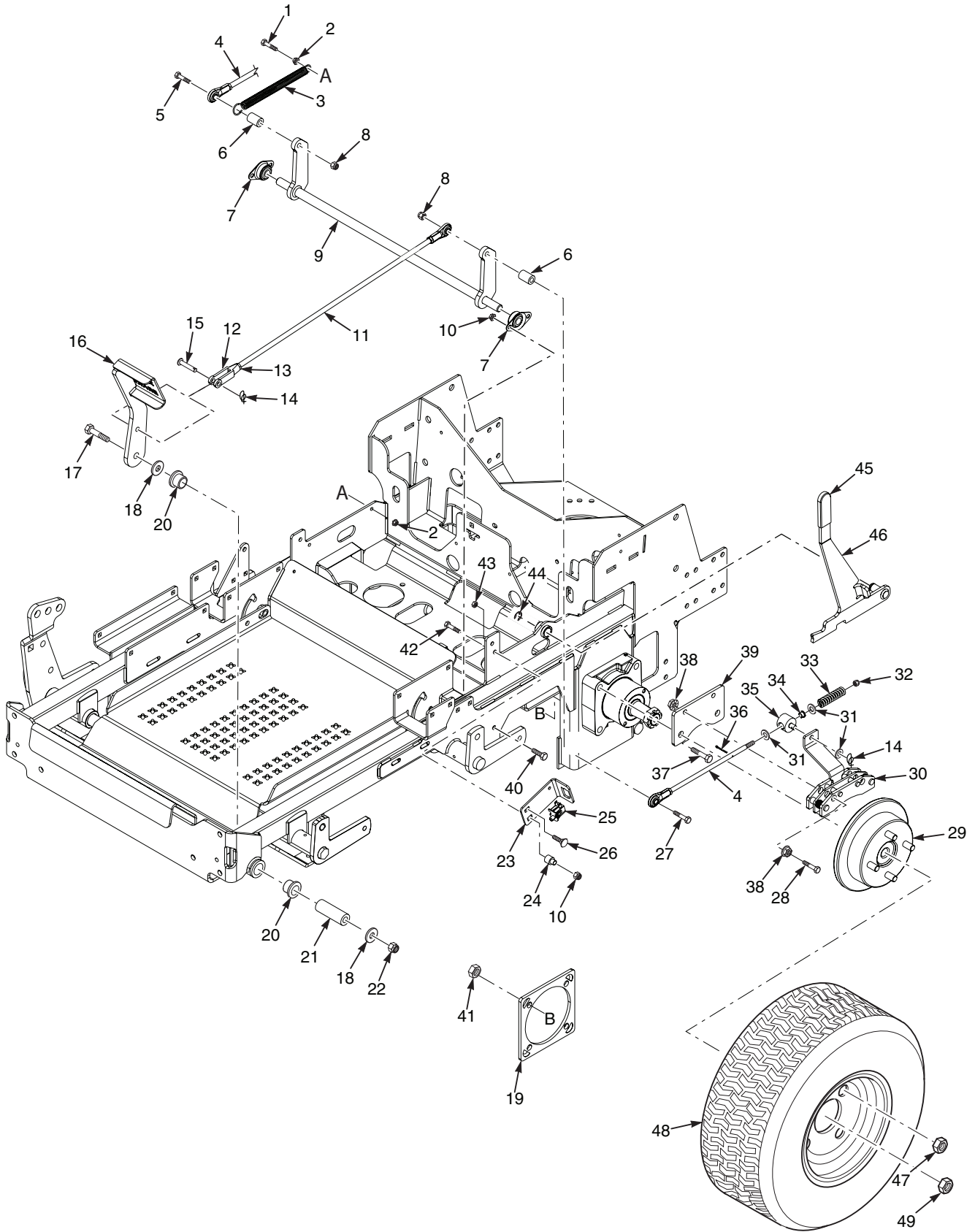



## BRAKE COMPONENTS

Ref. No.	Part No.	Description
1	04001-59	Bolt, Hex Head 1/4-20 x 1-1/4"
2	04019-02	Nut, Serrated Flange 1/4-20
3	485831	Spring, Brake Return
4	462465	Brake Link Assembly (incl. #31, 32, 33, 34, 35, 36)
5	04001-54	Bolt, Hex Head 3/8-16 x 3"
6	43805	Spacer
7	48796	Bearing, Self Align - 5/8" I.D.
8	04117-02	Nut, Flanged Elastic Stop 3/8-16
9	452342	Brake Bellcrank Weldment
10	04021-10	Nut, Elastic Stop 5/16-18
11	485740	Brake Rod Assembly (INCL. #12,13)
	48544	Rod End, 3/8-24 LH
	04020-26	Nut, 3/8-24 UNF LH Jam
12	48343-04	Clevis
13	04020-25	Nut, 3/8-24 UNF Jam
14	04069-01	Pin, Rue Cotter - 3/8" Dia.
15	04064-02	Clevis Pin, 3/8 x 1.06"
16	452327	Brake Pedal Weldment
17	04001-194	Bolt, Hex Head 1/2-13 x 4-1/4"
18	04040-13	Flatwasher, 1/2-.562 x 1.375 x .109
19	423279	Plate, Motor Backing
20	483453-03	Bearing
21	43872	Sleeve, Brake Pivot
22	04021-07	Nut, Elastic Stop 1/2-13
23	426992	Switch Mounting Bracket, Brake
24	43602	Spacer
25	481638	Switch
26	04003-02	Bolt, Carriage 1/4-20 x 3/4"
27	04001-54	Bolt, Hex Head 3/8-16 x 3"

Ref. No.	Part No.	Description
28	04001-87	Bolt, 1/2-13 x 4"
29	462808	Brake Hub
30	485595	Brake Caliper
31	04040-05	Flatwasher, 3/8-.406 x .812 x .065
32	04021-18	Nut, Elastic Stop 3/8-24
33	484535	Spring, Brake
34	483453-23	Bearing
35	462452	Swivel Assembly, Brake
36	04061-02	Cotter Pin, 3/32 x 3/4"
37	04001-190	Bolt, Hex Head 1/2-13 x 2-3/4"
38	04019-06	Nut, 1/2-13 Serrated Flange
39	428482	Mounting Bracket, Brake
40	04001-08	Bolt, Hex Head 5/16-18 x 3/4"
41	04021-19	Nut, Center Lock 1/2-13
42	04001-12	Bolt, Hex Head 5/16-18 x 1-3/4"
43	04021-08	Nut, Elastic Stop 1/4-20
44	04050-01	Retaining Ring, .625 Ext "E"
45	482102	Grip, Brake Lever
46	462820	Lever w/Grip, Parking Brake
47	04028-02	Wheel Nut, 1/2-20
48	485586	Wheel Assy 24 x 9.5-12 (48" Deck)
	485587	Rim (48" Deck)
	484105	Wheel Assy 24 x 9.5-12 (52" Deck))
	481659	Rim (52" Deck)
	484104	Tire 24 x 9.5-12 (48" & 52" Deck)
	481850	Wheel Assy 24 x 12-12 (61" Deck)
	481851	Rim (61" Deck)
	481852	Tire 24 x 12-12 (61" Deck)
49	48680	Nut, Castle 1"- 20 UNEF
*	04061-06	Pin, Cotter 9/64 x 1-1/2", Wheel Hub

\* = Not Shown

## HYDRAULIC SYSTEM

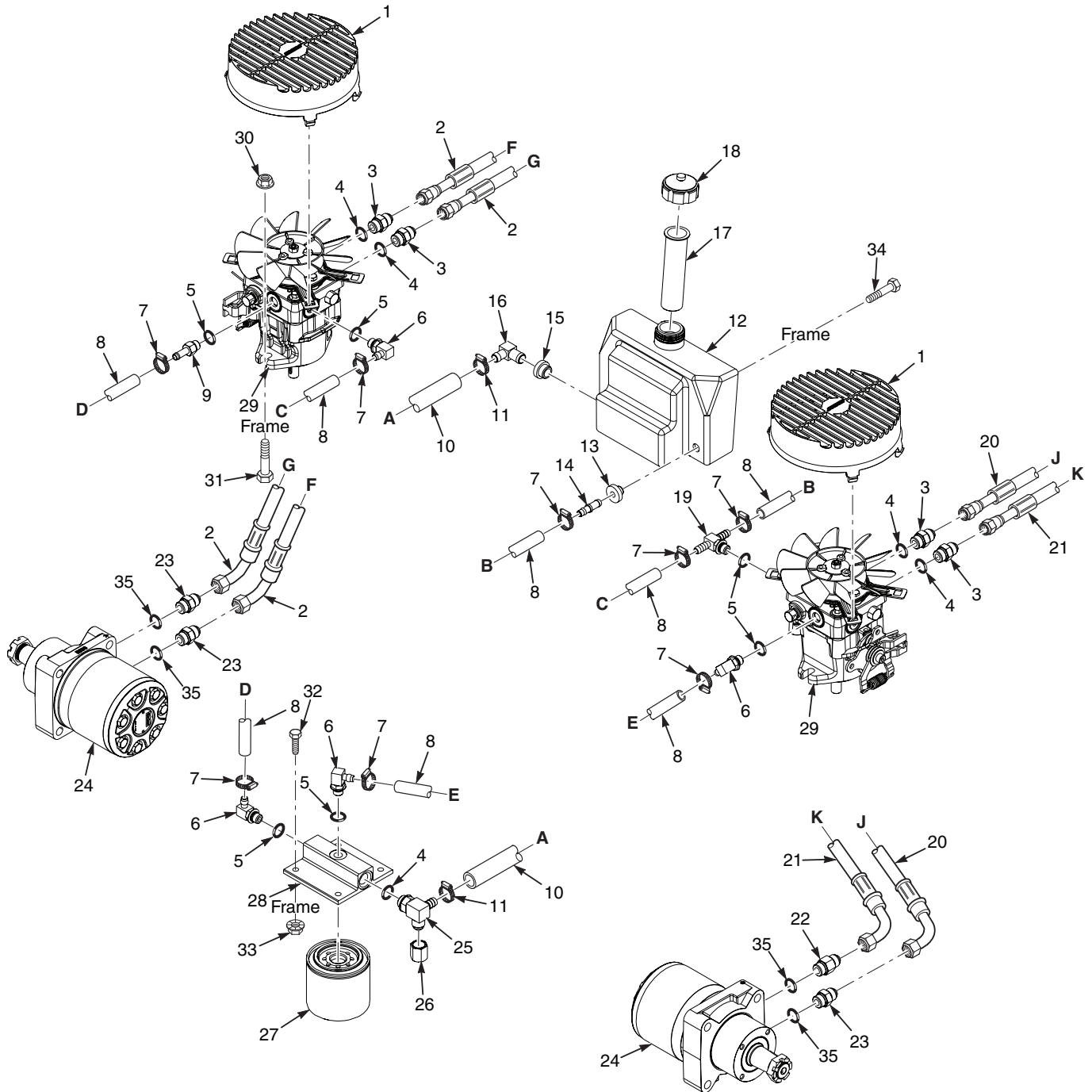

## HYDRAULIC SYSTEM

Ref. No.	Part No.	Description
1	485564	Fan Cover, Pump
2	484452	Hose Assembly
3	48572-04	Fitting, 1/2" JIC x 1/2" O-Ring
4	48603-02	O-Ring, 3/4"
5	48603-06	O-Ring, 7/16"
6	482266-01	Elbow, 90 Degree 9/16" O-Ring x 3/8" Hose
7	48136-13	Hose Clamp, .69" Dia.
8	48811	Hose, 3/8" Pushlock (order by inch)
9	482800-02	Fitting, 9/16" O-Ring x 3/8" Hose
10	48351	Hose, 1/2" Pushlock (order by inch)
11	48136-05	Hose Clamp, .87" Dia.
12	462801	Hydraulic Tank Assy (incl. #13, 14, 15, 16, 17, 18)
13	482571	Bushing
14	485590	Fitting, Straight
15	482573	Bushing
16	482574	Fitting
17	481507	Insert, Filler Neck
18	481164	Cap, Hydraulic Tank
19	482277	Tee Fitting, O-Ring to Barb
20	485603	Hose Assembly
21	485602	Hose Assembly
22	48572-10	Fitting, 1/2" JIC x 5/8" O-Ring (LH Wheel Motor - Upper Port Only)
23	48572-02	Fitting, 1/2" JIC x 5/8" O-Ring
24	482639	Wheel Motor, Parker
25	482483	Tee, 3/4" O-Ring x JIC x 1/2" Hose
26	48571-02	Cap
27	48462-01	Oil Filter
28	482417	Oil Filter Base
29	485573	Pump, LH (PK-3KCC-GA1F-XXXX)
	485574	Pump, RH (PK-3HCC-GA1F-XXXX)
30	04117-02	Nut, Flange Elastic Stop 3/8-16
31	04001-20	Bolt, Hex Head, 3/8-16 x 1-1/2"
32	04001-08	Bolt, Hex Head, 3/8-16 x 3/4"
33	04019-03	Nut, Serrated Flange 5/16-18
34	04017-15	Bolt, Hex Head, Serrated Flange 5/16-18 x 1/2"
35	48603-04	O-Ring, 5/8"

## STCII FUEL SYSTEM

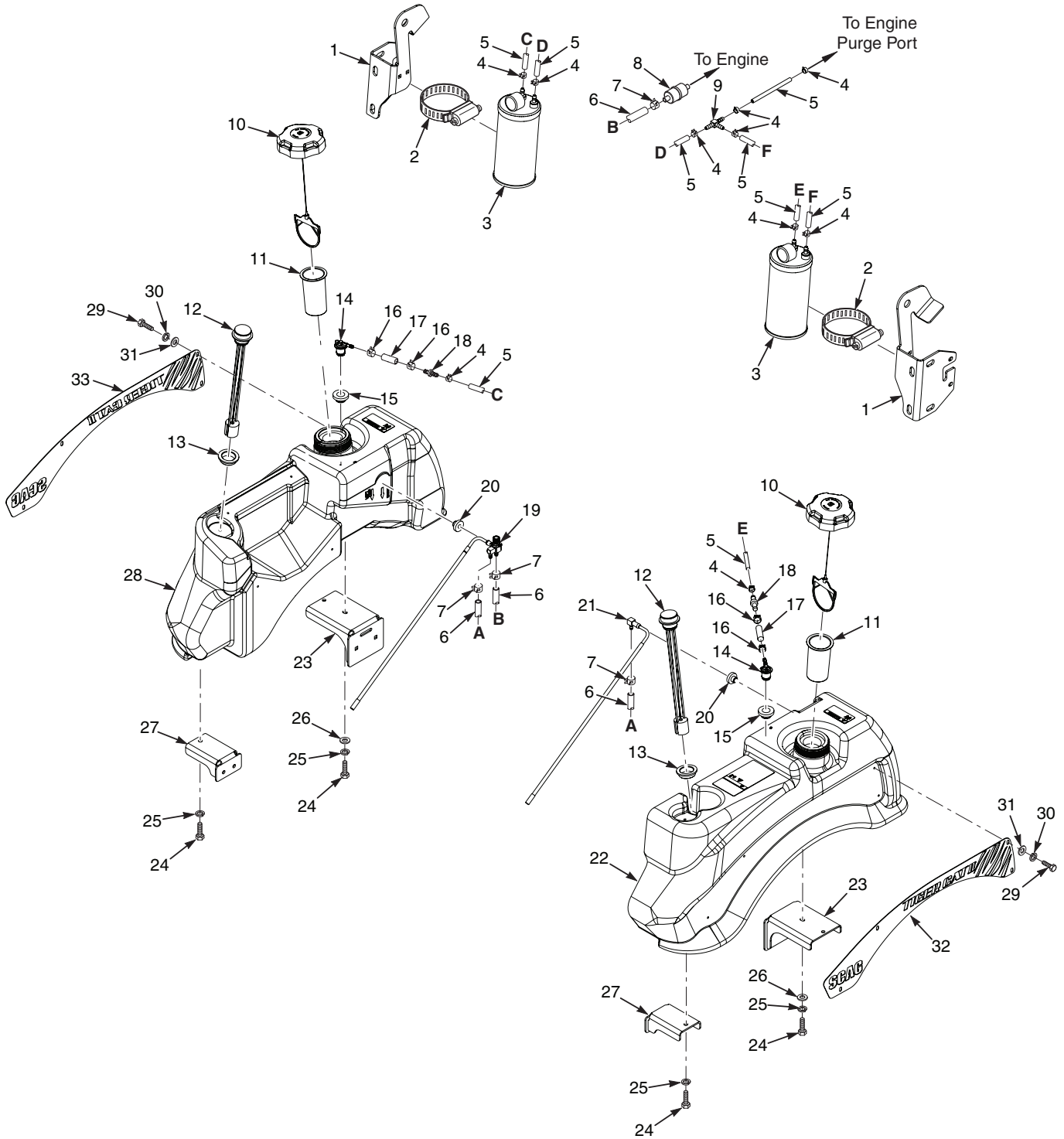

## STCII FUEL SYSTEM

Ref. No.	Part No.	Description
1	427028	ROPS Mount, LH, 22FX / 26FT-EFI / 25CV-EFI
	428574	ROPS Mount, LH, 27FX / 28BV-EFI / 32BV
	427029	ROPS Mount, RH, 22FX / 26FT-EFI / 25CV-EFI
	428575	ROPS Mount, RH, 27FX / 28BV-EFI / 32BV
2	48136-17	Clamp
3	484287	Carbon Canister, 400cc
	484366	Dust Filter, Carbon Canister
4	48059-05	Clamp, Vapor Recovery Hose
5	484345	Hose, 3/16" (order by inch)
6	483617	Hose, Non-Perm Fuel 1/4" I.D.
7	48059-01	Clamp, Fuel Hose 1/4" I.D.
8	**	Fuel Filter
9	48935-02	Tee, 3/16 x 3/16 x 3/16 Union, Hose Barb
10	484286	Fuel Cap, Tethered
	484297	Fuel Cap, Tethered (California Only)
11	484279-01	Tube, Fuel Tank Insert - 4"
12	484323	Fuel Gauge Assembly (incl. #13)
13	484242	Seal, Fuel Gauge
14	484333	Remote Vent
15	484285	Grommet, Viton
16	48059-02	Clamp, Fuel Hose 7/32
17	484347	Hose, Vapor Recovery (order by inch)
18	484343-01	Mender, 1/4 x 3/16
19	485637	Fuel Tube Assembly, Includes Valve
20	482571	Bushing, .56 Viton
21	484552	Fuel Tube Assembly, LH
22	463297	Fuel Tank Assembly, LH (incl. # 12, 14, 15, 20, 21, 29, 30, 31, 32)
23	427063	Mounting Bracket, Fuel Tank Rear
24	04001-08	Bolt, Hex Head 5/16-18 x 3/4"
25	04030-03	Lockwasher, 5/16" Spring
26	04040-15	Flatwasher, 5/16-.375 x .875 x .083
27	425862	Mounting Bracket, Fuel Tank Front
28	463299	Fuel Tank Assembly, RH (incl. #12, 14, 15, 19, 20, 29, 30, 31, 33)
29	04001-44	Bolt, Hex Head 1/4-20 x 1/2"
30	04030-02	Lockwasher, 1/4" Spring
31	04041-22	Flatwasher, 1/4-.256 x .490 x .0598
32	428700	Logo, Scag Tiger Cat II (RH)
33	428699	Logo, Scag Tiger Cat II (LH)

\*\* = Available through engine manufacturer only.

## ELECTRICAL SYSTEM

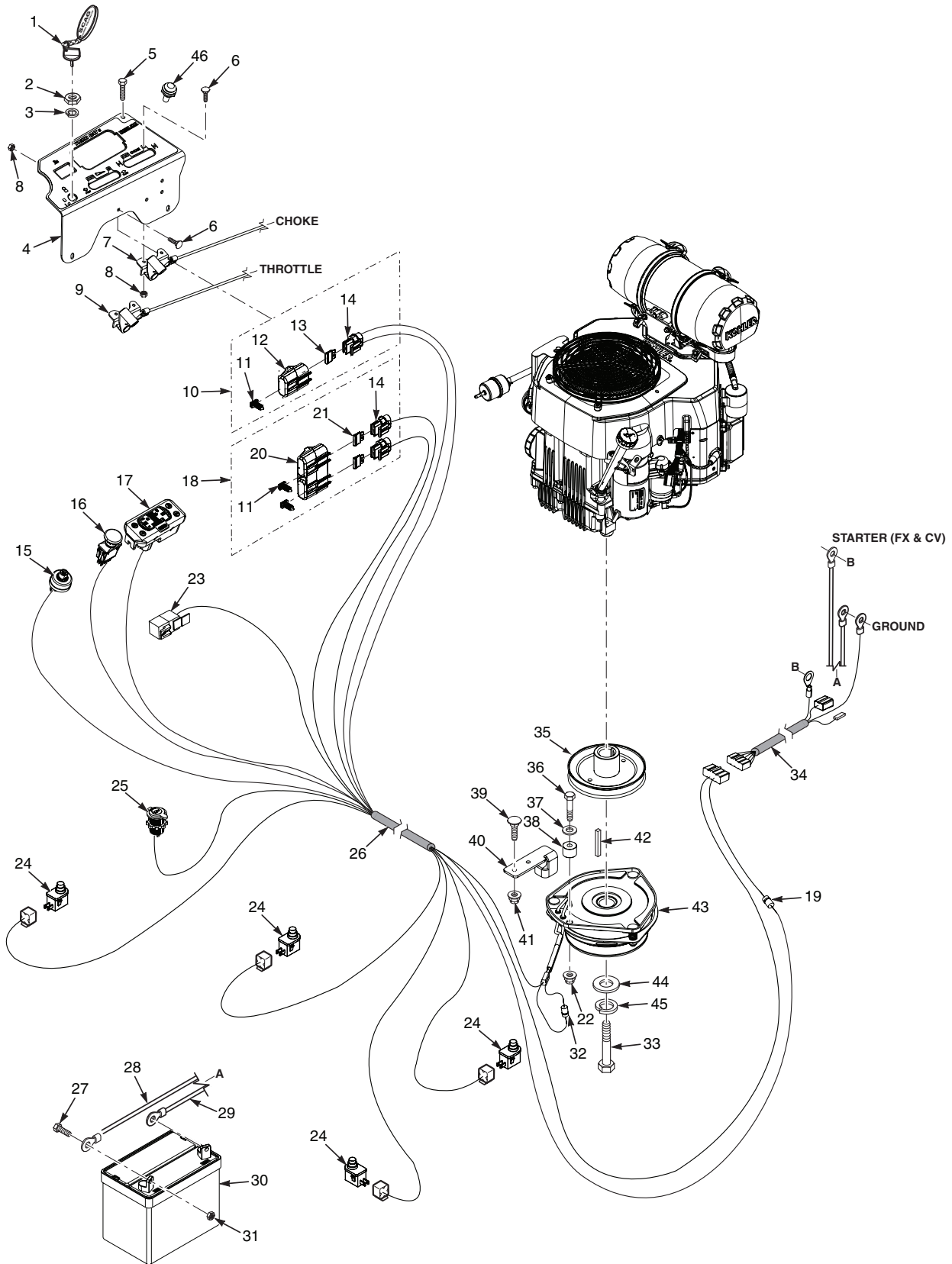

## ELECTRICAL SYSTEM

Ref. No.	Part No.	Description
1	462069	Key, Ignition
2	48017-04	Nut, Hex 5/8-32
3	48017-03	Lockwasher, 5/8" Internal
4	462862	Instrument Panel w/Decal
5	04017-04	Bolt, Hex Head Serrated Flange 1/4-20 x 1/2"
6	04003-43	Bolt, Carriage #10-24 x 1/2"
7	485628	Choke Control Cable (Kawasaki FX, Yamaha MX)
8	04021-26	Locknut, #10-24
9	485628	Throttle Control Cable
	486589	Throttle Control Cable (32BV & 28BV-EFI)
10	485739	Single Fuse Assy. (incl. #11, 12, 14)
11	482588	Clip, Wire
12	483643	Cover, Sealed Single
13	485674	Fuse, 5 Amp
14	483629	Fuse Holder
15	48798	Switch, Starter
16	485833	Switch, PTO
17	484721	Cluster Gauge
18	483642	Double Fuse Assy. (incl. #11, 14, 20, 21)
19	482253	Diode
20	483571	Cover, Sealed Double
21	48298	Fuse, 20 Amp
22	04021-10	Nut, Elastic Stop 5/16-18
23	483013	Relay
24	481638	Switch
25	485568	Power Plug
26	486013	Wire Harness - FX / Yamaha MX
	486125	Wire Harness - 28BV-EFI & 32BV
27	04001-44	Bolt, Hex Head 1/4-20 x 1/2"
28	48029-28	Battery Cable, 25" Red
29	48029-11	Battery Cable, 27" Black
30	*	Battery, 350 CCA
31	04020-02	Nut, 1/4-20 UNC
32	483958	Diode, 600V - 6A
33	04102-03	Bolt, Hex Head 7/16-20 x 2-1/4" w/Patch, B&S 28BV-EFI & 32BV
	04102-05	Bolt, Hex Head 7/16-20 x 2-3/4" w/Patch, Kawasaki FX / Yamaha MX
34	485678	Wire Harness Adapter, Kawasaki FX
	486946	Wire Harness Adapter 28BV-EFI
	487063	Wire Harness Adapter Yamaha MX
	486139	Wire Harness Adapter 32BV
35	485589	Pulley, 5.75" Dia. - 1.125 Bore
36	04001-17	Bolt, Hex Head 5/16-18 x 2"
37	04040-15	Flatwasher, 5/16-.375 x .875 x .083
38	431041	Bushing, UHMW
39	04003-12	Bolt, Carriage 5/16-18 x 3/4"
40	427330	Anti-Rotation Bracket
41	04117-01	Nut, Flange Elastic Stop 5/16-18
42	04063-28	Key, 1/4 x 1/4 x 3-1/2"
43	462339	Clutch, GT3.5 - 1.125 Bore
44	04041-28	Flatwasher, 7/16-.469 x 1.75 x .25
45	04030-05	Lockwasher, 7/16" Spring
46	481182	Indicator Light
**	48126	Rubber Boot, Battery Cable

\* = Not available through Scag.

\*\* = Not Shown

## ELECTRICAL SYSTEM - KAWASAKI 26FT-EFI

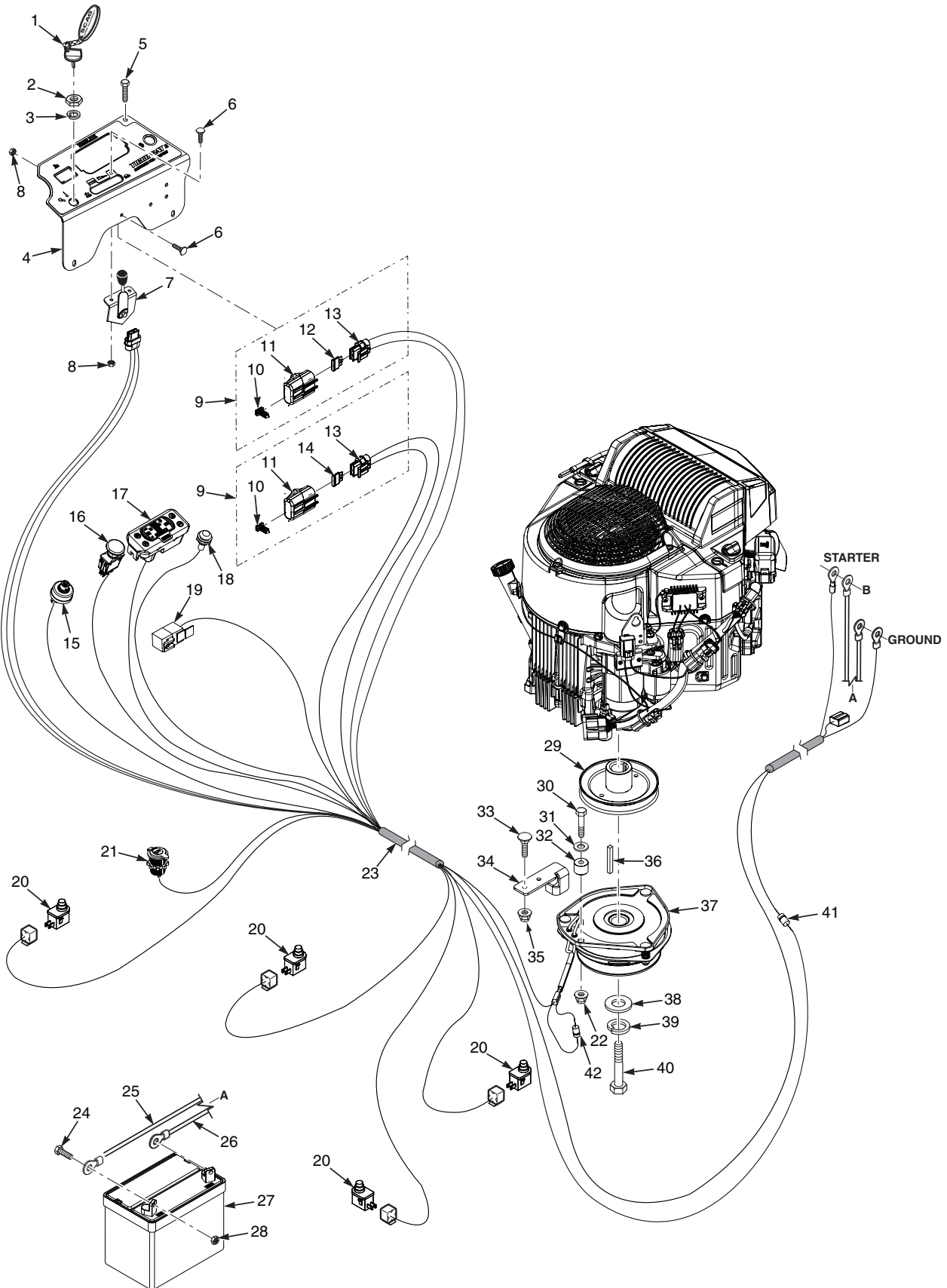



## ELECTRICAL SYSTEM - KAWASAKI 26FT-EFI

Ref. No.	Part No.	Description
1	462069	Key, Ignition
2	48017-04	Nut, Hex 5/8-32
3	48017-03	Lockwasher, 5/8" Internal
4	463050	Instrument Panel w/Decal
5	04017-04	Bolt, Hex Head Serrated Flange 1/4-20 x 1/2"
6	04003-43	Bolt, Carriage #10-24 x 1/2"
7	485464	Control, E-Gov Throttle
	483533	Knob, Throttle Control
8	04021-26	Locknut, #10-24
9	485739	Single Fuse Assy. (incl. #10, 11, 13)
10	482588	Clip, Wire
11	483643	Cover, Sealed Single
12	485674	Fuse, 5 Amp
13	483629	Fuse Holder
14	48298	Fuse, 20 Amp
15	48798	Switch, Starter
16	485833	Switch, PTO
17	484721	Cluster Gauge
18	481182	Indicator Light
19	483013	Relay
20	481638	Switch
21	485568	Power Plug
22	04021-10	Nut, Elastic Stop 5/16-18
23	486124	Wire Harness, STCII-26FT-EFI
24	04001-44	Bolt, Hex Head 1/4-20 x 1/2"
25	48029-28	Battery Cable, 25" Red
26	48029-11	Battery Cable, 27" Black
27	*	Battery, 350 CCA
28	04020-02	Nut, 1/4-20 UNC
29	485589	Pulley, 5.75" Dia. - 1.125 Bore
30	04001-17	Bolt, Hex Head 5/16-18 x 2"
31	04040-15	Flatwasher, 5/16-.375 x .875 x .083
32	431041	Bushing, UHMW
33	04003-12	Bolt, Carriage 5/16-18 x 3/4"
34	427330	Anti-Rotation Bracket
35	04117-01	Nut, Flange Elastic Stop 5/16-18
36	04063-28	Key, 1/4 x 1/4 x 3-1/2"
37	462339	Clutch, GT3.5 - 1.125 Bore
38	04041-28	Flatwasher, 7/16-.469 x 1.75 x .25
39	04030-05	Lockwasher, 7/16" Spring
40	04102-05	Bolt, Hex Head 7/16-20 x 2-3/4" w/Patch
41	482253	Diode
42	483958	Diode, 600V - 6A
**	48126	Rubber Boot, Battery Cable

\* = Not available through Scag.

\*\* = Not Shown

## ELECTRICAL SYSTEM - KOHLER EFI / YAMAHA EFI

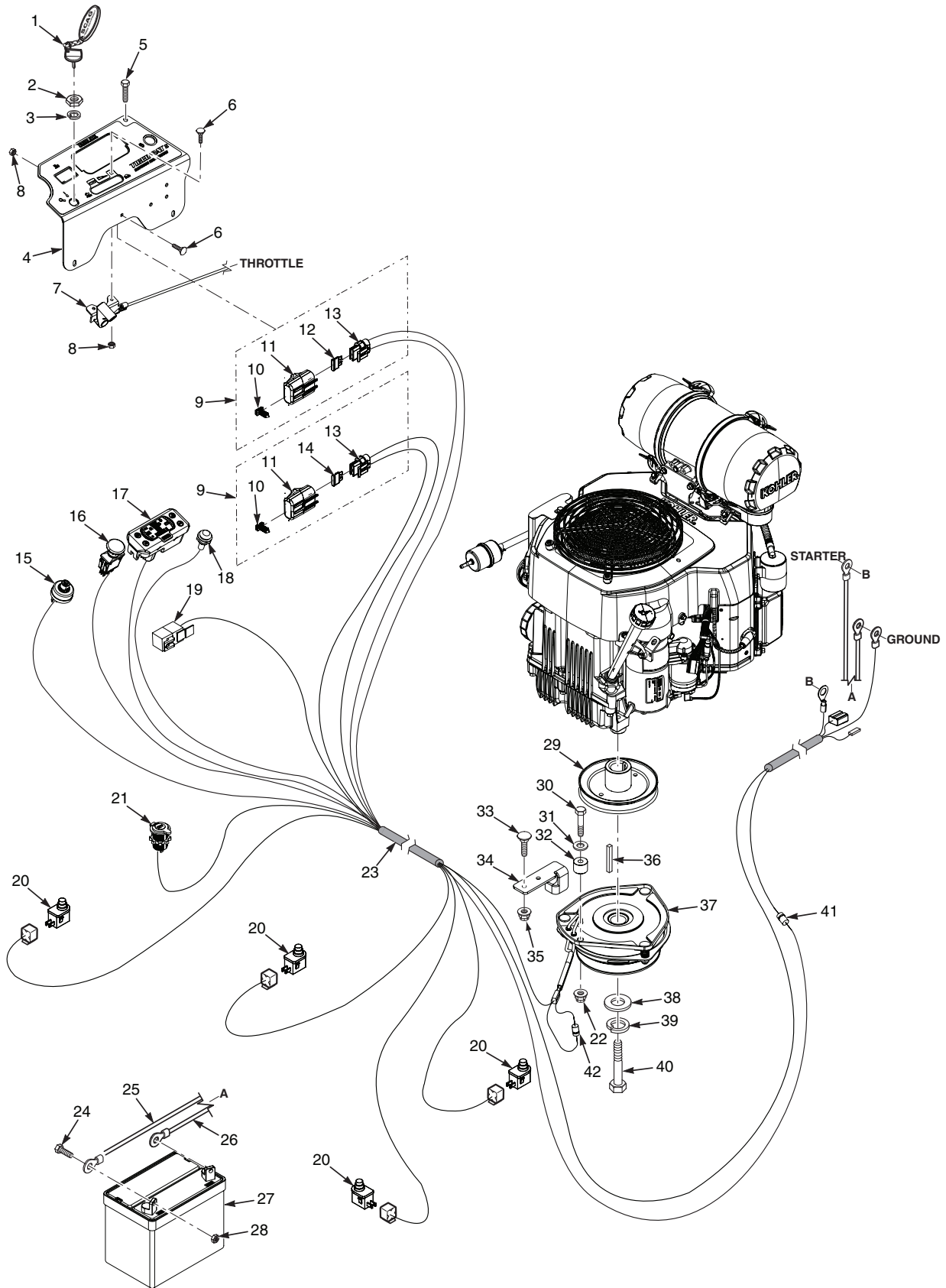

## ELECTRICAL SYSTEM - KOHLER EFI / YAMAHA EFI

Ref. No.	Part No.	Description
1	462069	Key, Ignition
2	48017-04	Nut, Hex 5/8-32
3	48017-03	Lockwasher, 5/8" Internal
4	462862	Instrument Panel w/Decal
5	04017-04	Bolt, Hex Head Serrated Flange 1/4-20 x 1/2"
6	04003-43	Bolt, Carriage #10-24 x 1/2"
7	485628	Throttle Control Cable
8	04021-26	Locknut, #10-24
9	485739	Single Fuse Assy. (incl. #10, 11, 13)
10	482588	Clip, Wire
11	483643	Cover, Sealed Single
12	485674	Fuse, 5 Amp
13	483629	Fuse Holder
14	48298	Fuse, 20 Amp
15	48798	Switch, Starter
16	485833	Switch, PTO
17	484721	Cluster Gauge
18	481182	Indicator Light
19	483013	Relay
20	481638	Switch
21	485568	Power Plug
22	04021-10	Nut, Elastic Stop 5/16-18
23	486125	Wire Harness, STCII-CV-EFI / YAMAHA-EFI
24	04001-44	Bolt, Hex Head 1/4-20 x 1/2"
25	48029-28	Battery Cable, 25" Red
26	48029-11	Battery Cable, 27" Black
27	*	Battery, 350 CCA
28	04020-02	Nut, 1/4-20 UNC
29	485589	Pulley, 5.75" Dia. - 1.125 Bore
30	04001-17	Bolt, Hex Head 5/16-18 x 2"
31	04040-15	Flatwasher, 5/16-.375 x .875 x .083
32	431041	Bushing, UHMW
33	04003-12	Bolt, Carriage 5/16-18 x 3/4"
34	427330	Anti-Rotation Bracket
35	04117-01	Nut, Flange Elastic Stop 5/16-18
36	04063-28	Key, 1/4 x 1/4 x 3-1/2"
37	462339	Clutch, GT3.5 - 1.125 Bore
38	04041-28	Flatwasher, 7/16-.469 x 1.75 x .25
39	04030-05	Lockwasher, 7/16" Spring
40	04102-03	Bolt, Hex Head 7/16-20 x 2-1/4" w/Patch
	04103-05	Bolt, Hex Head 7/16-20 x 2-3/4" w/Patch - Yamaha EFI
41	482253	Diode
42	483958	Diode, 600V - 6A
**	48126	Rubber Boot, Battery Cable

\* = Not available through Scag.

\*\* = Not Shown

## STCII HYDRAULIC PUMP ASSEMBLY

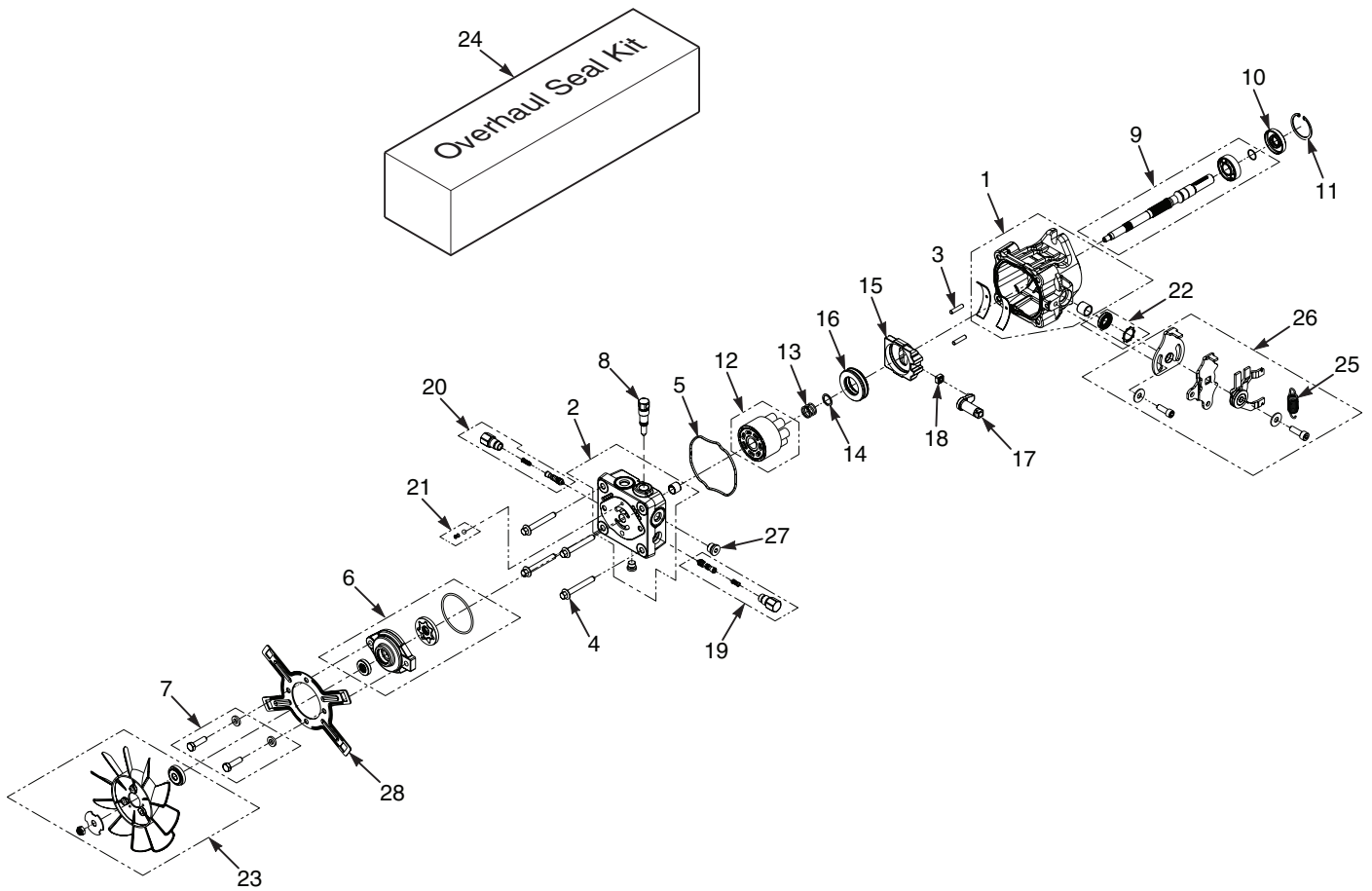

## STCII HYDRAULIC PUMP ASSEMBLY

Ref. No.	Part No.	Description
1	HG 71717	Housing Kit
2	HG 72011	End Cap Kit
3	HG 50641	Straight Headless Pin
4	HG 50969	Hex Flange Bolt, M8-1.25 x 60mm
5	HG 54022	Housing O-Ring
6	HG 71247	Charge Pump Kit
7	HG 72254	Charge Pump Bolt Kit
8	HG 2513030	Bypass Valve Kit
9	HG 70620	Pumpshaft Kit
10	HG 51161	Lip Seal
11	HG 50329	Retaining Ring (Internal)
12	HG 71971	Cylinder Block Kit
13	HG 2003014	Block Spring
14	HG 2003017	Flat Washer
15	HG 2003087	Swash Plate
16	HG 53502	Thrust Bearing
17	HG 52866	Trunnion Arm
18	HG 2000015	Slot Guide
19	HG 70743	Shock Valve Kit (.031" Orifice)
20	HG 70743	Shock Valve Kit (.031" Orifice)
21	HG 70402	Charge Relief Kit
22	HG 2513043	Trunnion Seal with Retainer
23	HG 70811	Fan/Hub Kit
24	HG 70525	Overhaul Seal Kit
25	HG 52401	Spring, Extension
26	HG 71716	RTN Kit (Std Scissor, Std Spring)
27	HG 9005110-5600	Straight Thread Plug
28	HG 52355	Bracket

## REPLACEMENT DECALS AND INFORMATION PLATES

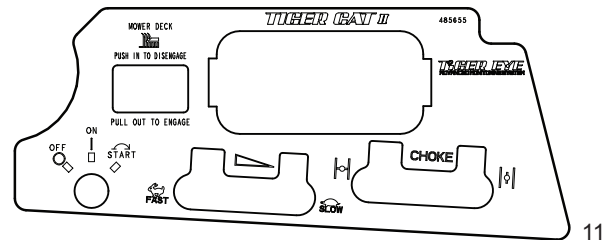
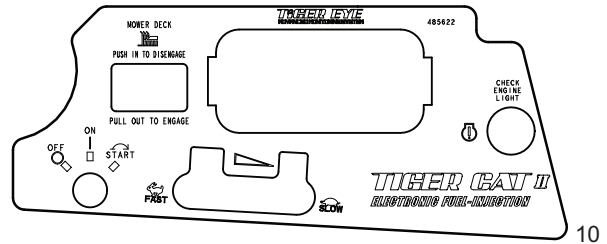
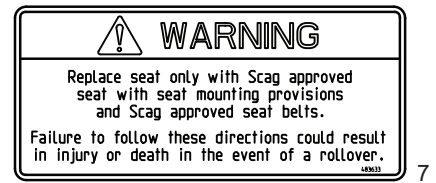
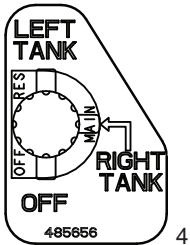
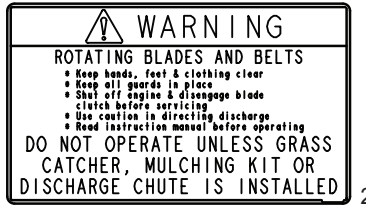

## REPLACEMENT DECALS AND INFORMATION PLATES

Ref. No.	Part No.	Description
1	483407	Decal, Danger-Spinning Blades
2	483406	Decal, Warning-Rotating Blades
3	485403	Decal, Metalcraft - USA
4	485656	Decal, Fuel Valve Position
5	482100	Decal, Traction Control
6	483425	Decal, ROPS
7	483633	Decal, Seat Replacement
8	483402	Decal, Belt Cover
9	484453	Decal, Heavy Duty Commercial
10	485622	Decal, Instrument Panel - Kohler EFI
	485932	Decal, Instrument Panel - Kawasaki EFI
11	485655	Decal, Instrument Panel
12	484134	Decal, Deck Height - LH
13	484135	Decal, Deck Height - RH
14	485629	Decal, Tiger Cat II
15	483199	Decal, 48V
	483200	Decal, 52V
	483201	Decal, 61V
16	485654	Decal, Seat Support
17	485521	Decal, Belt Routing (48V & 52V)
	485522	Decal, Belt Routing (61V)
18	486285	Decal, STCII Replacement Parts
19	485551	Decal, Start/Drive
20	483405	Decal, Warning
21	486203	Decal, Scag
22	486202	Decal, Scag Tiger Cat II
**	462893	Spanish Decal Kit, (not shown)
**	01411	DVD Video, Tips for Safe Operation of Your Scag Zero-Turn Mower

**IMPORTANT ADJUSTMENT PROCEDURES**  
**READ OPERATOR'S MANUAL FOR MORE DETAILS**  
 Check tire pressure - (Drive tires-12 psi)  
 - (Caster tires-25 psi)

**NEUTRAL ADJUSTMENT**  
 Loosen jam nuts  
 Rotate turnbuckle  
 With an operator in the seat, engine running, control lever in neutral and the parking brake disengaged - adjust control linkage. Loosen jam nuts. If wheel rotates forward, adjust turnbuckle CW. If wheel rotates rearward, adjust turnbuckle CCW. Adjust until drive wheel stops turning. Tighten jam nuts. Repeat procedure until proper Neutral Adjustment is obtained.

**TRACKING ADJUSTMENT**  
 If the machine pulls to the right, adjust LH control linkage CW to slow left wheel. If the machine pulls to the left adjust RH control linkage CW to slow right wheel. Readjust neutral if necessary.

**FREE WHEEL OPERATION**  
 To move machine without running the engine, rotate both dump valves located at the LH side of the jumps CW 1/2 turn to "freewheel" positions. Return dump valves to original position to operate the mower. Tighten to 7-10 ft-lbs.

**HYDRAULIC FLUID LEVEL**  
 Check hydraulic fluid level while fluid is cool. Fluid level should be 2" below top of filler neck. Fill with SAE 20W50 motor oil only.

**IMPORTANT**  
 Do not overfill. Room for hot fluid expansion must be allowed or resulting expansion may cause leaks in the system.

485654

16

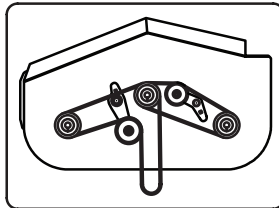

17

**WARNING**

DO NOT OPERATE WITHOUT DISCHARGE CHUTE, MULCHING KIT, OR ENTIRE GRASS CATCHER INSTALLED

483405

20

**Replacement Parts Numbers TIGER CAT III**

**Always use original Scag replacement parts for top machine performance and to maintain factory warranty.**

Blk, Pump Drive HP 4 821	486448	Standard Blk, Cutter HP1	482877
Blk, Pump Drive HP1	486448	Standard Blk, Cutter 821	482878
Blk, Cutter Deck-LH HP1	486334	Standard Blk, Cutter HP1	482878
Blk, Cutter Deck-RH HP1	482230	Spindle Dress: MidRange 20" 222	
Blk, Cutter Deck-LH 821	486336	Excess Blade From HP	
Blk, Cutter Deck-RH 821	482240	Excess Blade Drive 821	
Blk, Cutter Deck-LH HP1	486336	Filter, Hydraulic 80 micron	48482-01
Blk, Cutter Deck-RH HP1	483857		

See your authorized Scag dealer for engine part numbers.

18

**START/DRIVE PROCEDURE**

- Engage parking brake
- Disengage mower deck drive
- Move control handles to neutral lock position
- Start engine
- Release parking brake
- Select forward or reverse with hydro control handles

**WARNING**

AVOID SERIOUS INJURY OR DEATH

- Read the Operator's Manual
- Solicite etiquetas en español a un distribuidor Scag
- Operate only on slopes you can back up and never on slopes greater than 15 degrees
- If machine stops going uphill, stop blades and back down slowly
- Avoid sudden turns
- Do not mow when children or others are around
- Never carry children even with blades off
- Look down and behind before and while backing
- Keep safety devices (guards, shields, switches, etc.) in place and working
- Remove objects that could be thrown by the blades
- Trained operators only

485551

19



21



22

## STCII - KAWASAKI FX / YAMAHA MX ELECTRICAL SCHEMATIC

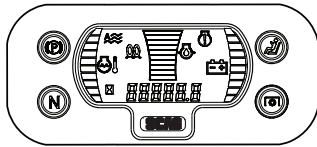

Position	Key Switch Legend
OFF	G + M + A
RUN	B + L + A
START	B + L + S

Position	PTO Switch Legend												
ON (UP)	<table border="1"> <tr><td>1</td><td>2</td><td>3</td><td>4</td><td>5</td><td>6</td></tr> <tr><td>7</td><td>8</td><td>9</td><td>10</td><td>11</td><td>12</td></tr> </table>	1	2	3	4	5	6	7	8	9	10	11	12
1	2	3	4	5	6								
7	8	9	10	11	12								
DOWN (OFF)	<table border="1"> <tr><td>1</td><td>2</td><td>3</td><td>4</td><td>5</td><td>6</td></tr> <tr><td>7</td><td>8</td><td>9</td><td>10</td><td>11</td><td>12</td></tr> </table>	1	2	3	4	5	6	7	8	9	10	11	12
1	2	3	4	5	6								
7	8	9	10	11	12								

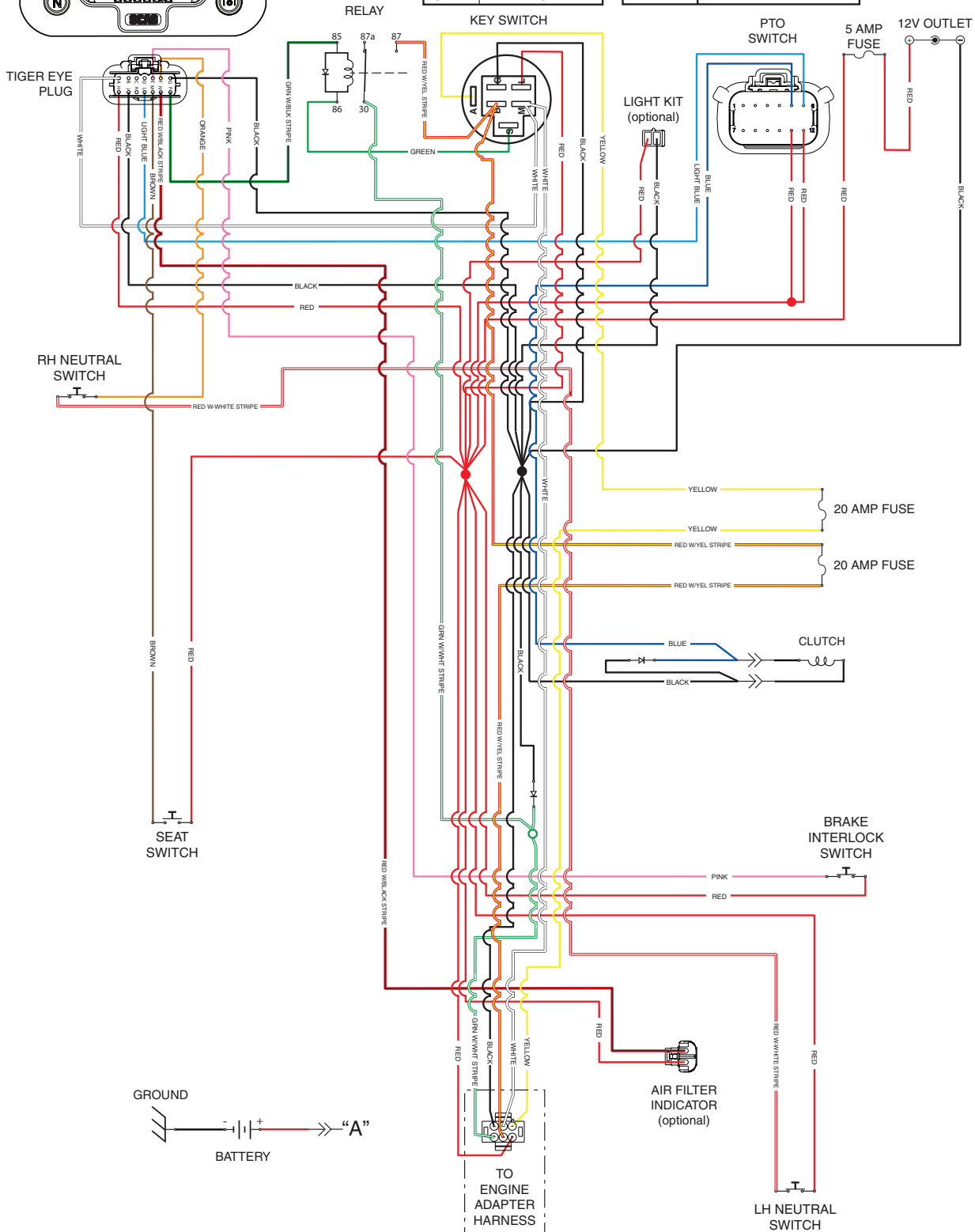



## STCII KAWASAKI FX ENGINE ADAPTER ELECTRICAL SCHEMATIC P/N 485678

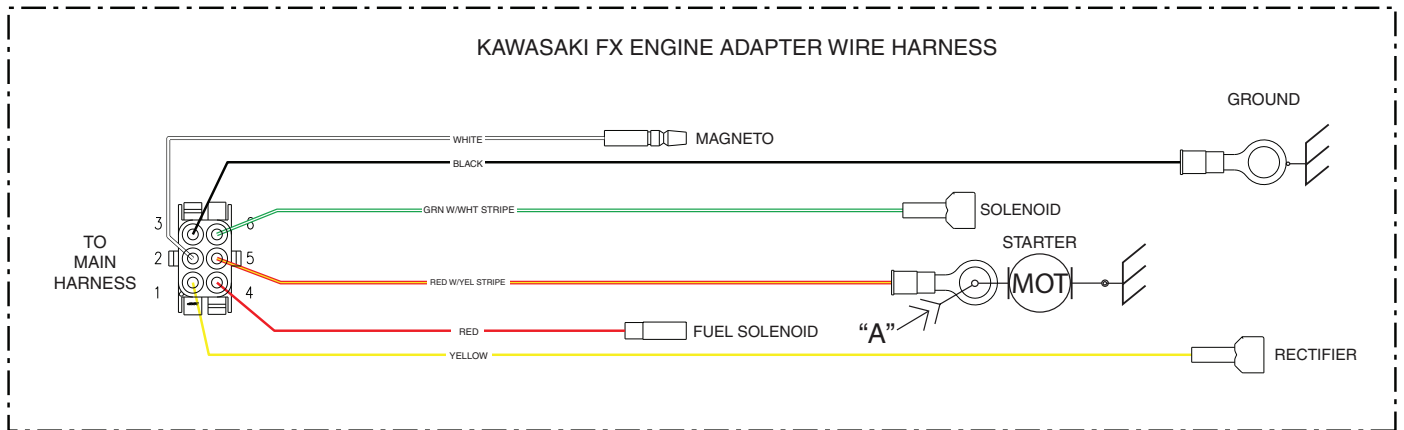

## STCII YAMAHA MX ENGINE ADAPTER ELECTRICAL SCHEMATIC P/N 487063

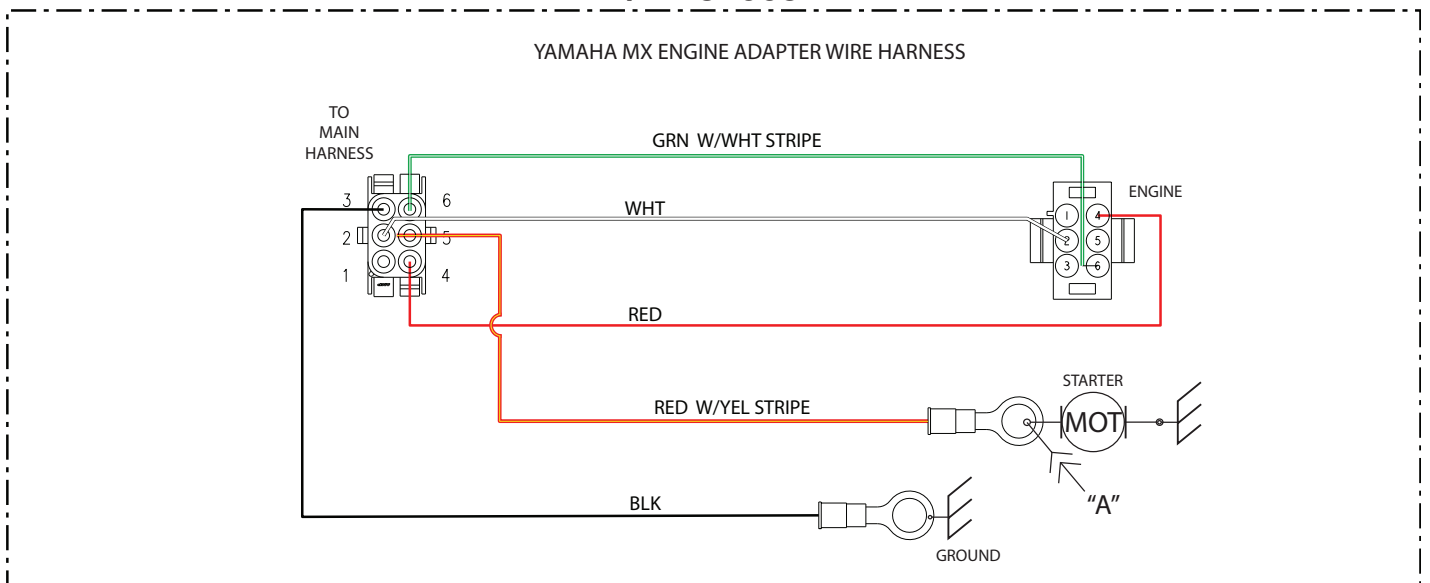

## STCII - KAWASAKI 26FT EFI ELECTRICAL SCHEMATIC

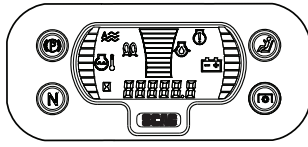

Position	Key Switch Legend
OFF	G + M + A
RUN	B + L + A
START	B + L + S

KEY SWITCH

Position	PTO Switch Legend												
ON (UP)	<table border="1"> <tr><td>1</td><td>2</td><td>3</td><td>4</td><td>5</td><td>6</td></tr> <tr><td>7</td><td>8</td><td>9</td><td>10</td><td>11</td><td>12</td></tr> </table>	1	2	3	4	5	6	7	8	9	10	11	12
1	2	3	4	5	6								
7	8	9	10	11	12								
DOWN (OFF)	<table border="1"> <tr><td>1</td><td>2</td><td>3</td><td>4</td><td>5</td><td>6</td></tr> <tr><td>7</td><td>8</td><td>9</td><td>10</td><td>11</td><td>12</td></tr> </table>	1	2	3	4	5	6	7	8	9	10	11	12
1	2	3	4	5	6								
7	8	9	10	11	12								

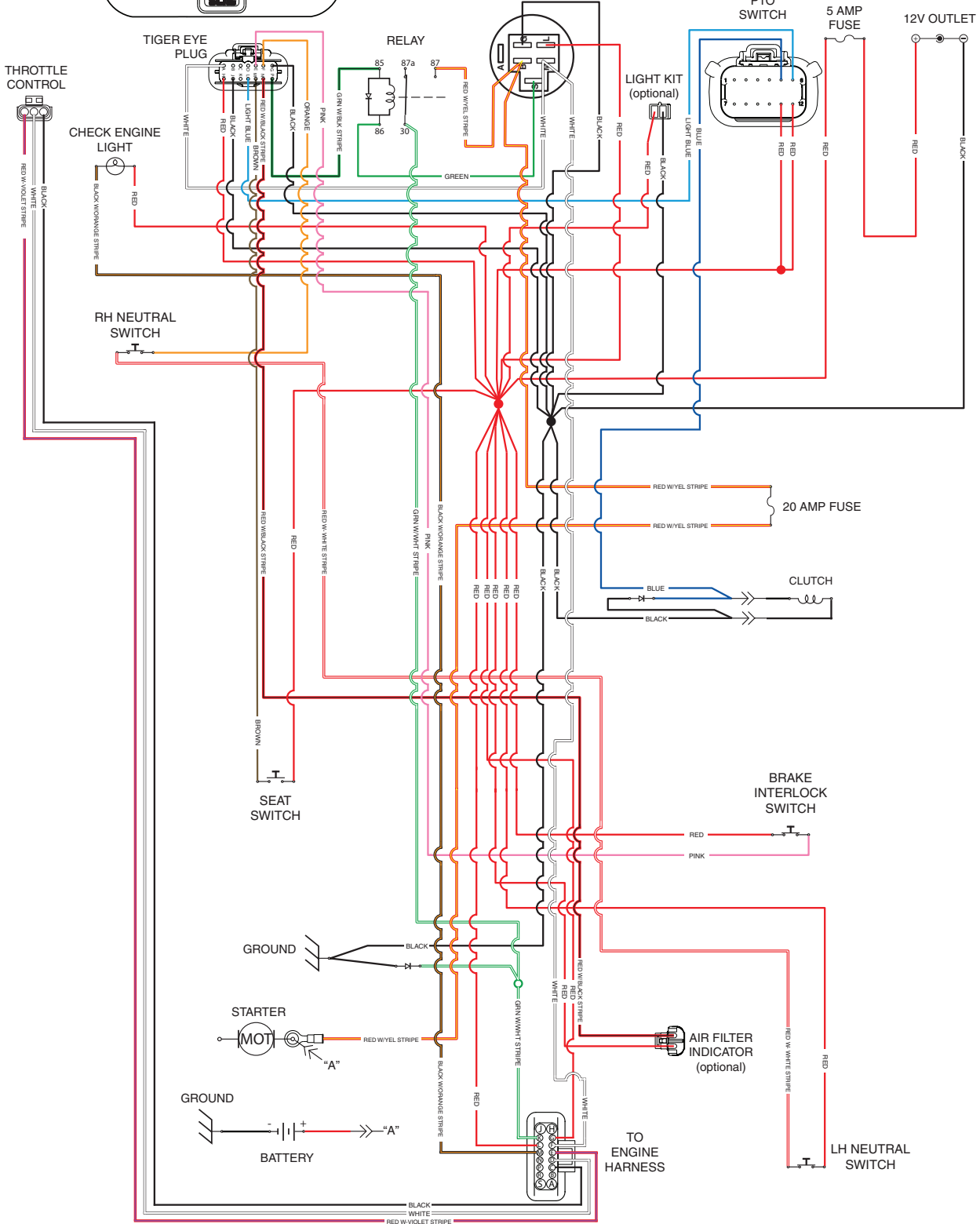

## STCII - KOHLER 25CV-EFI ELECTRICAL SCHEMATIC STCII - BRIGGS & STRATTON 28BV-EFI / 32BV ELECTRICAL SCHEMATIC STCII - YAMAHA MX-EFI

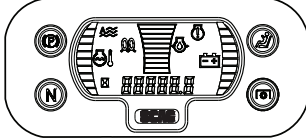

Position	Key Switch Legend
OFF	G + M + A
RUN	B + L + A
START	B + L + S

Position	PTO Switch Legend
ON (UP)	
DOWN (OFF)	

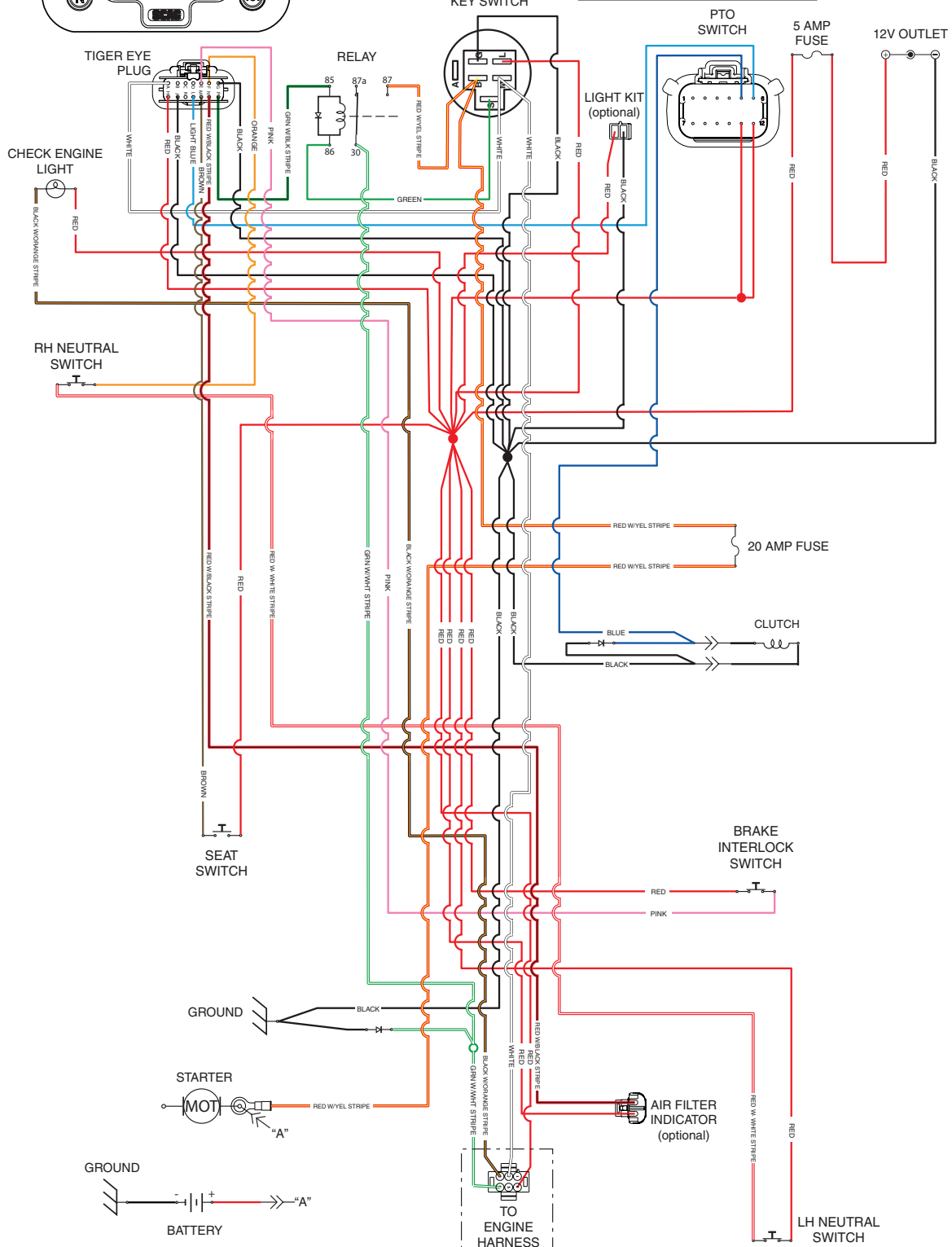

## STCII BRIGGS & STRATTON 28BV-EFI ENGINE ADAPTER ELECTRICAL SCHEMATIC P/N 486946

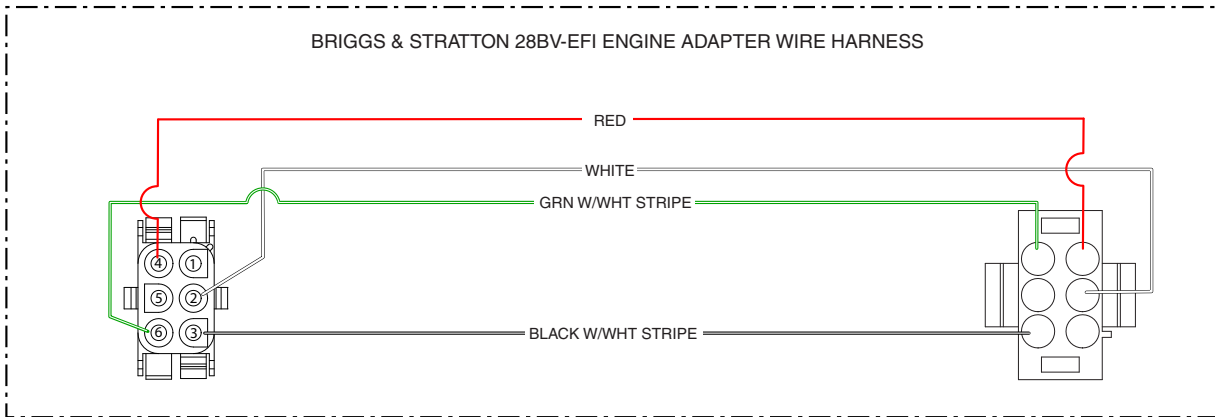

## STCII BRIGGS & STRATTON 32BV ENGINE ADAPTER ELECTRICAL SCHEMATIC P/N 486139

