

SCAG[®]

POWER EQUIPMENT

OPERATOR'S MANUAL

V-RIDE II



Model: **SVR11-36A-15FS**
 SVR11-36A-19FX
 SVR11-48V-22FX
 SVR11-52V-23FX
 SVR11-52V-25CV-EFI
 SVR11-61V-25FX
 SVR11-61V-29CV-EFI

Congratulations on owning a Scag mower! This manual contains the operating instructions and safety information for your Scag mower. Reading this manual can provide you with assistance in maintenance and adjustment procedures to keep your mower performing to maximum efficiency. The specific models that this book covers are listed on the inside cover. Before operating your machine, please read all the information enclosed.



WARNING

FAILURE TO FOLLOW SAFE OPERATING PRACTICES MAY RESULT IN SERIOUS INJURY OR DEATH.

- Read this manual completely as well as other manuals that came with your mower.
- ALWAYS FOLLOW OSHA APPROVED OPERATION.
- DO NOT operate on steep slopes.
- Under no circumstances should the machine be operated on slopes greater than 20 degrees. ALWAYS FOLLOW OSHA APPROVED OPERATION.
- Stay two cut widths away from slopes, drop offs, ditches and retaining walls.
- DO NOT back down a slope or ramp.
- DO NOT mow on wet grass. Wet grass reduces traction and steering control.
- Keep all shields in place, especially the grass discharge chute.
- Before performing any maintenance or service, stop the machine and remove the spark plug wire and ignition key.
- If a mechanism becomes clogged, stop the engine before cleaning.
- Keep hands, feet and clothing away from power-driven parts.
- Keep others off the mower (only one person at a time)

REMEMBER - YOUR MOWER IS ONLY AS SAFE AS THE OPERATOR!

HAZARD CONTROL AND ACCIDENT PREVENTION ARE DEPENDENT UPON THE AWARENESS, CONCERN, PRUDENCE, AND PROPER TRAINING OF THE PERSONNEL INVOLVED IN THE OPERATION, TRANSPORT, MAINTENANCE, AND STORAGE OF THE EQUIPMENT.

This manual covers the operating instructions and illustrated parts list for:

SVRII-36A-15FS	with a serial number of	M9500001 to M9599999
SVRII-36A-19FX	with a serial number of	M9600001 to M9699999
SVRII-48V-22FX	with a serial number of	M9700001 to M9799999
SVRII-52V-23FX	with a serial number of	M9800001 to M9899999
SVRII-52V-25CV-EFI	with a serial number of	M9900001 to M9999999
SVRII-61V-25FX	with a serial number of	N0000001 to N0099999
SVRII-61V-29CV-EFI	with a serial number of	N0100001 to N0199999

Always use the entire serial number listed on the serial number tag when referring to this product.

Table of Contents

SECTION 1 - GENERAL INFORMATION	1
1.1 INTRODUCTION.....	1
1.2 DIRECTION REFERENCE	1
1.3 SERVICING THE ENGINE AND DRIVE TRAIN COMPONENTS.....	1
1.4 SYMBOLS	2
SECTION 2 - SAFETY INFORMATION	3
2.1 INTRODUCTION.....	3
2.2 SIGNAL WORDS	3
2.3 BEFORE OPERATION CONSIDERATIONS.....	3
2.4 OPERATION CONSIDERATIONS.....	4
2.5 MAINTENANCE CONSIDERATIONS & STORAGE	6
2.6 USING A SPARK ARRESTOR.....	7
2.7 SPARK IGNITION SYSTEM	7
2.8 SAFETY AND INSTRUCTIONAL DECALS	8
SECTION 3 - SPECIFICATIONS	9
3.1 ENGINE	9
3.2 ELECTRICAL	9
3.3 ENGINE DECK	9
3.4 CUTTER DECK	10
3.5 WEIGHTS AND DIMENSIONS.....	10
3.6 PRODUCTIVITY	10
SECTION 4 - OPERATING INSTRUCTIONS	11
4.1 TIGER EYE INSTRUMENT IDENTIFICATION (EXCLUDES SVR11-36A)	11
4.2 CONTROLS IDENTIFICATION	13
4.3 SAFETY INTERLOCK SYSTEM	13
4.4 INITIAL RUN-IN PROCEDURES.....	14
4.5 STARTING THE ENGINE	14
4.6 GROUND TRAVEL AND STEERING	14
4.7 ENGAGING THE DECK DRIVE (CUTTER BLADES).....	15
4.8 HILLSIDE OPERATION.....	16
4.9 PARKING THE MOWER	16
4.10 AFTER OPERATION	17
4.11 REMOVING CLOGGED MATERIAL	17
4.12 MOVING MOWER WITH ENGINE STOPPED	17
4.13 RECOMMENDATIONS FOR MOWING.....	17
4.14 ADJUSTING CUTTING HEIGHT	18
SECTION 5 - TROUBLESHOOTING CUTTING CONDITIONS	19

SECTION 6 - ADJUSTMENTS	22
6.1 PARKING BRAKE ADJUSTMENT	22
6.2 TRAVEL ADJUSTMENT	22
6.3 THROTTLE CONTROL AND CHOKE ADJUSTMENTS	24
6.4 BELT ADJUSTMENTS	24
6.5 BELT ALIGNMENT	24
6.6 CUTTER DECK ADJUSTMENTS	24
6.7 ELECTRIC CLUTCH ADJUSTMENT	29
6.8 OPERATOR CUSHION AND REAR COVER REMOVAL	30
SECTION 7 - MAINTENANCE	31
7.1 MAINTENANCE CHART - RECOMMENDED SERVICE INTERVALS	31
7.2 LUBRICATION	32
7.3 HYDRAULIC SYSTEM	34
7.4 ENGINE OIL	35
7.5 ENGINE FUEL SYSTEM	36
7.6 ENGINE AIR CLEANER	37
7.7 BATTERY - ELECTRIC START MODELS	37
7.8 DRIVE BELTS	38
7.9 CUTTER BLADES	38
7.10 TIRES	40
7.11 BODY AND DECK	40
SECTION 8 - ILLUSTRATED PARTS LIST	41
8.1 SCAG APPROVED ATTACHMENTS AND ACCESSORIES	41
36A CUTTER DECK	42
48V, 52V & 61V CUTTER DECKS	44
SVR11 CUTTER DECK CONTROLS	46
SVR11 SHEET METAL COMPONENTS	48
SVR11 STEERING CONTROLS	50
SVR11 FUEL SYSTEM	52
SVR11-36A HYDRAULICS AND ENGINE COMPONENTS	54
SVR11-48V / 52V / 61V HYDRAULICS AND ENGINE COMPONENTS	56
SVR11-36A ELECTRICAL SYSTEM	58
SVR11-36A ELECTRICAL SYSTEM - RECOIL START MODELS	60
SVR11-48V / 52V / 61V ELECTRICAL SYSTEM	62
SVR11-36A HYDRAULIC PUMP	64
SVR11-48V / 52V / 61V HYDRAULIC PUMP	66
REPLACEMENT DECALS AND INFORMATION PLATES	68
SVR11-36 ELECTRICAL SCHEMATIC - RECOIL START MODELS	70
SVR11-36 ELECTRICAL SCHEMATIC	71
SVR11 ELECTRICAL SCHEMATIC - ELECTRIC START MODELS	72
SVR11-EFI ELECTRICAL SCHEMATIC	73
KAWASAKI ENGINE ADAPTER ELECTRICAL SCHEMATIC	74
LIMITED WARRANTY - COMMERCIAL EQUIPMENT	INSIDE BACK COVER

GENERAL INFORMATION

1.1 INTRODUCTION

Your mower was built to the highest standards in the industry. However, the prolonged life and maximum efficiency of your mower depends on you following the operating, maintenance and adjustment instructions in this manual.

If additional information or service is needed, contact your Scag Power Equipment Dealer.

We encourage you to contact your dealer for repairs. All Scag dealers are informed of the latest methods to service this equipment and provide prompt and efficient service in the field or at their service shop. They carry a full line of Scag service parts.

- IMPORTANT -

The replacement of any part on this product by other than the manufacturer's authorized replacement part may adversely affect the performance, durability or safety of this product.

Use of other than original Scag replacement parts will void the warranty.

When ordering parts, always give the model and serial number of your mower. The serial number plate is located on the frame of the machine between the engine and hydraulic pump where shown in Figure 1-1.

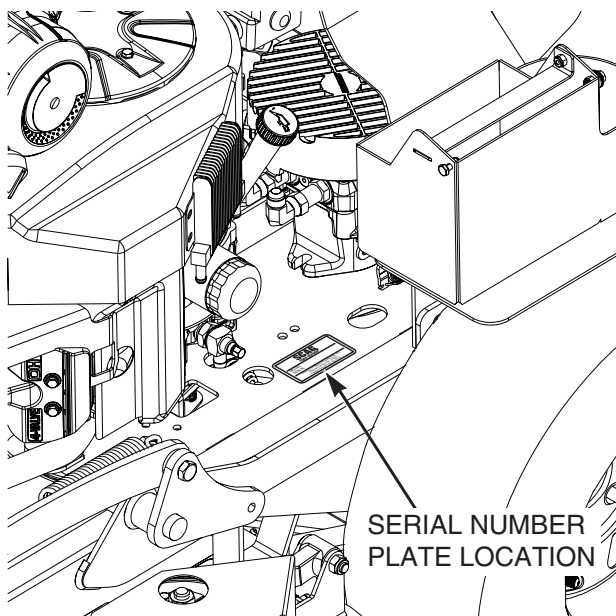

Figure 1-1. Mower Serial Number Plate Location

USE ONLY SCAG APPROVED ATTACHMENTS AND ACCESSORIES.

Attachments and accessories manufactured by companies other than Scag Power Equipment are not approved for use on this machine. See Section 8-1.

WARNING

For pictorial clarity, some illustrations and figures in this manual may show shields, guards or plates open or removed. Under no circumstances should your mower be operated without these devices in place.

All information is based upon product information available at the time of approval for printing. Scag Power Equipment reserves the right to make changes at any time without notice and without incurring any obligation.

















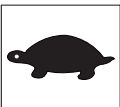

1.2 DIRECTION REFERENCE

The “Right” and “Left”, “Front” and “Rear” of the machine are referenced from the operator’s right and left when in the normal operating position and facing the forward travel direction.

1.3 SERVICING THE ENGINE AND DRIVE TRAIN COMPONENTS

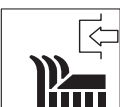
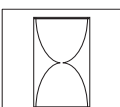
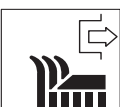
The detail servicing and repair of the engine and transmission are not covered in this manual; only routine maintenance and general service instructions are provided. For service of these components during the limited warranty period, it is important to contact your Scag dealer or find a local authorized servicing agent of the component manufacturer. Any unauthorized work done on these components during the warranty period may void your warranty.

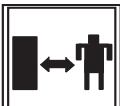
1.4 SYMBOLS

SYMBOL	DESCRIPTION	SYMBOL	DESCRIPTION
	Choke		Transmission
	Parking Brake		Spinning Blade
	On/Start		Spring Tension on Idler
	Off/Stop		Oil
	Falling Hazard		Thrown Object Hazard
	Fast		Slow
	Continuously Variable - Linear		Cutting Element - Basic Symbol
	Pinch Point		Cutting Element - Engage
	Hour meter/Elapsed Operating Hours		Cutting Element - Disengage
	Crush Hazard.		CE Mark
	Keep Bystanders Away		Read Operator's Manual

SAFETY INFORMATION

2.1 INTRODUCTION

Your mower is only as safe as the operator. Carelessness or operator error may result in serious bodily injury or death. Hazard control and accident prevention are dependent upon the awareness, concern, prudence, and proper training of the personnel involved in the operation, transport, maintenance and storage of the equipment. Make sure every operator is properly trained and thoroughly familiar with all of the controls before operating the mower. The owner/user can prevent and is responsible for accidents or injuries occurring to themselves, other people or property.

READ THIS OPERATOR'S MANUAL BEFORE ATTEMPTING TO START YOUR MOWER.

A replacement manual is available from your authorized Scag Service Dealer or by contacting Scag Power Equipment, Service Department at P.O. Box 152, Mayville, WI 53050 or contact us via the Internet at www.scag.com. The manual for this machine can be downloaded by using the model and serial number or use the contact form to make your request. Please indicate the complete model and serial number of your Scag product when requesting replacement manuals.

2.2 SIGNAL WORDS



This symbol means **“Attention! Become Alert! Your Safety is Involved!”** The symbol is used with the following signal words to attract your attention to safety messages found on the decals on the machine and throughout this manual. The message that follows the symbol contains important information about safety. To avoid injury and possible death, carefully read the message! Be sure to fully understand the causes of possible injury or death.

SIGNAL WORD:

It is a distinctive word found on the safety decals on the machine and throughout this manual that alerts the viewer to the existence and relative degree of the hazard.

DANGER

The signal word “DANGER” denotes that an extremely hazardous situation exists on or near the machine that could result in high probability of death or irreparable injury if proper precautions are not taken.

WARNING

The signal word “WARNING” denotes that a hazard exists on or near the machine that can result in injury or death if proper precautions are not taken.

CAUTION

The signal word “CAUTION” is a reminder of safety practices on or near the machine that could result in personal injury if proper precautions are not taken.

Your safety and the safety of others depends significantly upon your knowledge and understanding of all correct operating practices and procedures of this machine.

2.3 BEFORE OPERATION CONSIDERATIONS

WARNING

Check all hydraulic connections for tightness. Inspect all hydraulic hoses and / or lines to ensure they are in good condition before operating.

1. NEVER allow children to operate this mower. Do not allow adults to operate this machine without proper instructions.
2. Do not mow when children and/or others are present. Keep children out of the mowing area and in the watchful care of a responsible adult other than the operator. Be alert and turn machine off if a child enters the area.

3. DO NOT allow children to ride or play on the machine, it is not a toy.
4. Clear the area to be mowed of objects that could be picked up and thrown by the cutter blades.
5. DO NOT carry passengers.
6. DO NOT operate the machine under the influence of alcohol or drugs.
7. If the operator(s) or mechanic(s) cannot read English, it is the owner's responsibility to explain this material to them.
8. DO NOT wear loose fitting clothing. Loose clothing, jewelry or long hair could get tangled in moving parts. Do not operate the machine wearing shorts; always wear adequate protective clothing including long pants. Wearing safety glasses, safety shoes and a helmet is advisable and is required by some local ordinances and insurance regulations.



WARNING

Always wear hearing protection. Operating this machine over prolonged periods of time can cause loss of hearing.

9. Keep the machine and attachments in good operating condition. Keep all shields and safety devices in place. If a shield, safety device or decal is defective or damaged, repair or replace it before operating the machine.



WARNING

This machine is equipped with an interlock system intended to protect the operator and others from injury. This is accomplished by preventing the engine from starting unless the deck drive is disengaged, the parking brake is engaged, the steering control levers are in the neutral position and the operator is in the operator position. The interlock system shuts off the engine if the operator leaves the operator platform with the steering control levers not in the neutral position and/or the cutter blades engaged and the parking brake not engaged.

10. Be sure the interlock switches are functioning correctly.
11. Fuel is flammable; handle it with care. Fill the fuel

tank outdoors. Never fill it indoors. Use a funnel or spout to prevent spillage. Clean up any spillage before starting the engine.

12. DO NOT add fuel to a running or hot engine. Allow the engine to cool for several minutes before adding fuel. Never fuel indoors or inside enclosed trailers.
13. Keep flammable objects (cigarettes, matches, etc.), open flames and sparks away from the fuel tank and fuel container. Use only approved containers.
14. Equipment must comply with the latest requirements per SAE J137 and/or ANSI/ASAE S279 when driven on public roads.
15. Do not operate without the side discharge chute installed and in the down position or with an optional grass catcher or mulch plate completely installed.
16. Check the blade mounting bolts at frequent intervals for proper tightness.
17. Make sure all hydraulic fluid connections are tight and all hydraulic hoses and lines are in good condition before starting the machine.

2.4 OPERATION CONSIDERATIONS

1. Know the function of all controls and how to stop quickly.



WARNING

DO NOT operate on steep slopes. Under no circumstances should the machine be operated on slopes greater than 20 degrees. See Figure 2-1 to determine approximate slope of area to be mowed. ALWAYS FOLLOW OSHA APPROVED OPERATION.

2. Reduce speed and exercise extreme caution on slopes and in sharp turns to prevent tipping or loss of control. Be especially cautious when changing directions on slopes.
3. Stay two cut widths away from slopes, drop offs, ditches and retaining walls.
4. To prevent tipping or loss of control, start and stop smoothly, avoid unnecessary turns and travel at reduced speed.
5. Immediately apply the parking brake if you lose steering control while operating. Inspect the machine and correct the problem before continuing to operate.

Section 2

6. When using any attachment, never direct the discharge of material toward bystanders or allow anyone near the machine while in operation.
7. Start the engine with the operator in the operating position, cutter blades are disengaged, parking brake is engaged, and the neutral lever is in neutral.
8. If the mower discharge ever plugs, shut off the engine, remove the ignition key, and wait for all movement to stop before removing the obstruction.

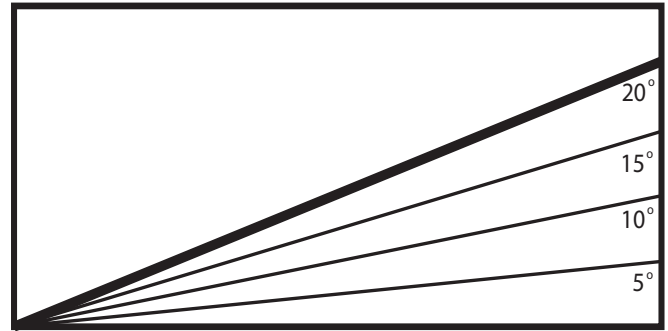

Figure 2-1. Slope Angle Graph

WARNING

DO NOT use your hand to dislodge the clogged discharge chute. Use a stick or other device to remove clogged material after the engine has stopped running and the blades have stopped turning.

9. Be alert for holes, rocks, roots and other hidden hazards in the terrain. Keep away from any drop offs. Beware of overhead obstructions (low limbs, etc.), underground obstacles (sprinklers, pipes, tree roots, etc.). Cautiously enter a new area. Be alert for hidden hazards.
10. Disengage power to cutter deck before backing up. Do not mow in reverse unless absolutely necessary and then only after observation of the entire area behind the mower. If you must mow in reverse, maintain a constant lookout to the rear of the machine and mow slowly.
11. DO NOT turn sharply. Use care when backing up.
12. Disengage power to cutter deck before crossing roads, walks or gravel drives.
13. Mow only in daylight or good artificial light.
14. NEVER raise the deck with the blades engaged.
15. Take all possible precautions when leaving the machine unattended, such as disengaging the mower, stopping the engine, and removing the key.
16. Disengage power to the attachments when transporting or when not in use.
17. The machine and attachments should be stopped and inspected for damage after striking a foreign object, and damage should be repaired before restarting and operating the machine.

CAUTION

Do not touch the engine or the muffler while the engine is running or immediately after stopping. These areas may be hot enough to cause a burn.

DANGER

DO NOT run the engine inside a building or a confined area without proper ventilation. Exhaust fumes are hazardous and contain carbon monoxide which can cause brain injury and death.

18. Keep hands and feet away from cutter blades and moving parts. Contact can injure.
19. Transport the mower using a heavy duty trailer or truck. Ensure the trailer or truck has all of the necessary lighting and markings as required by laws, codes, and ordinances. Secure a trailer with a safety chain.
20. Be cautious when loading and unloading onto trailers or trucks. Use only a full width ramp. Always back on and drive off a trailer.
21. When transporting the mower, make sure the neutral lock lever is in neutral lock, the engine is off with the key removed, the parking brake is engaged and the wheels have been blocked.

22. Tie the mower down securely using the tie down points located on the front and rear of the machine. See Figure 2-2 and 2-3. Secure using straps, chains, cable, or ropes. Both front and rear straps must be directed down and outward from machine.

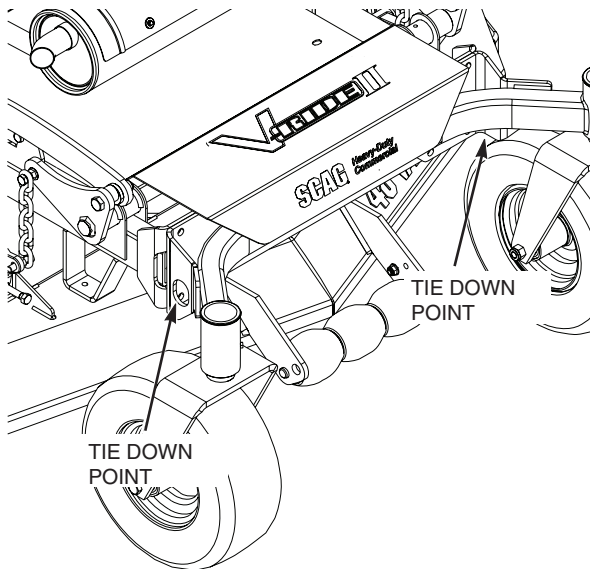

Figure 2-2. Front Tie Down Points

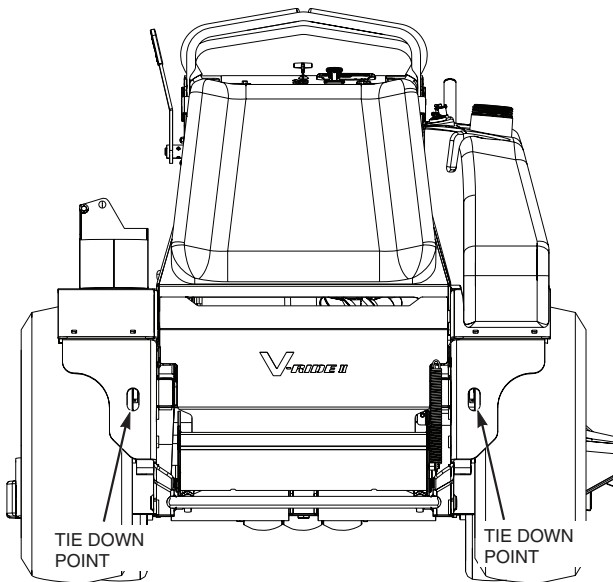

Figure 2-3. Rear Tie Down Points

23. Use care when approaching blind corners, shrubs, trees, or other objects that may obscure vision.
24. NEVER leave the machine running unattended.

2.5 MAINTENANCE CONSIDERATIONS & STORAGE

1. Never make adjustments to the machine with the engine running unless specifically instructed to do so. If the engine is running, keep hands, feet, and clothing away from moving parts.
2. Place the control levers in the neutral position, engage the parking brake, stop engine and remove key or disconnect spark plug wire to prevent accidental starting of the engine when servicing or adjusting the machine. Wait for all movement to stop before adjusting, cleaning or repairing.
3. Remove spark plug wire before making any repairs.
4. Keep all nuts, bolts and screws tight, to ensure the machine is in safe working condition. Check blade mounting bolts frequently to be sure they are tight.
5. Do not change the engine governor settings or overspeed the engine. See the engine operator's manual for information on engine settings.
6. To reduce fire hazard, keep the cutting units, drives, muffler and engine free of grass, leaves, excessive grease, oil and dirt.
7. Park the machine on level ground.
8. NEVER allow untrained personnel to service the machine.
9. Use care when checking blades. Use a Blade Buddy, wrap the blade(s) or wear gloves and USE CAUTION when servicing blades. Only replace blades. NEVER straighten or weld blades.
10. Keep all parts in good working condition. Replace all worn or damaged decals.
11. Use jack stands to support components when required.
12. Carefully release pressure from components with stored energy.

 **WARNING**

Hydraulic fluid is under high pressure and can penetrate skin causing injury. If hydraulic fluid is injected into the skin, it must be surgically removed within a few hours by a doctor or gangrene may result.

Keep body and hands away from pinholes or nozzles that eject hydraulic fluid under high pressure. Use paper or cardboard and not hands to search for leaks.

Safely relieve all pressure from the hydraulic system by placing the control levers in the neutral lock position and shutting off the engine before performing any work on the hydraulic system.

If you need service on your hydraulic system, please see your authorized Scag dealer.

13. Let the engine cool before storing.
14. DO NOT store the machine near an open flame.
15. Shut off fuel while storing or transporting.
16. DO NOT store fuel near flames or drain indoors.

2.6 USING A SPARK ARRESTOR

The engine in this machine is not equipped with a spark arrestor muffler. It is in violation of California Public Resource Code Section 4442 to use or operate this engine on or near any forest covered, brush covered or grass covered land unless the exhaust system is equipped with a spark arrestor meeting any applicable local or state laws. Other states or federal areas may have similar laws. Check with your state or local authorities for regulations pertaining to these requirements.

2.7 SPARK IGNITION SYSTEM

This spark ignition system complies with Canadian ICES-002.

2.8 SAFETY AND INSTRUCTIONAL DECALS



483407

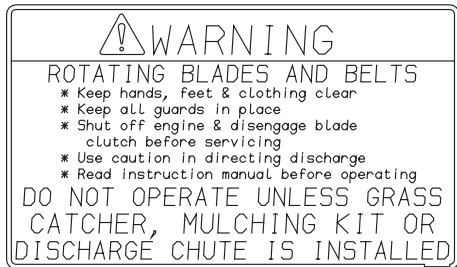

483406

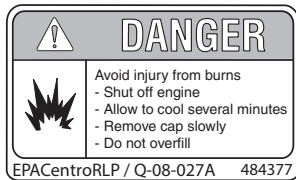

Molded in Fuel Tank

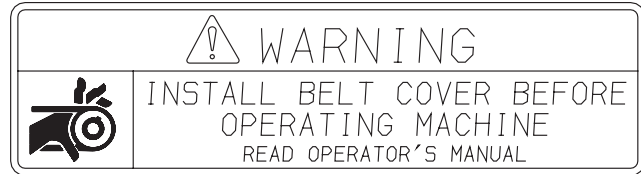

483402



483405

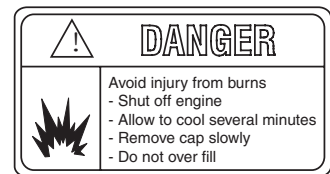

484281

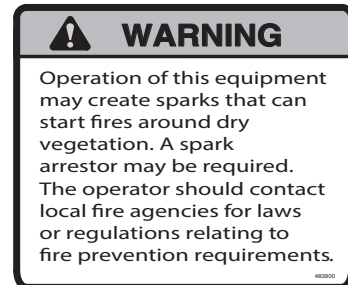

483900

(supplied with California models only)

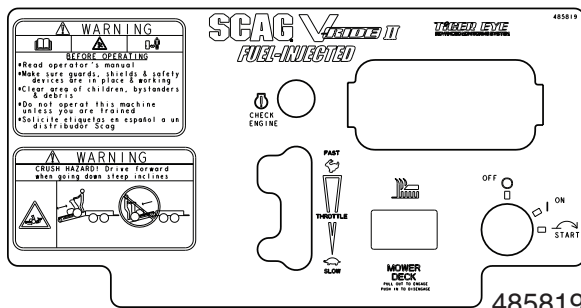

485819

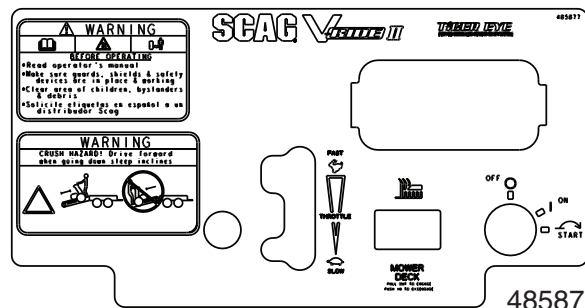

485877

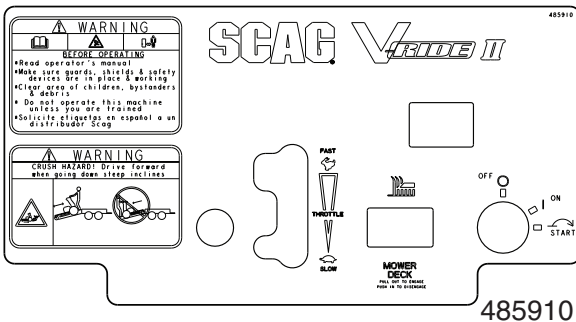

485910

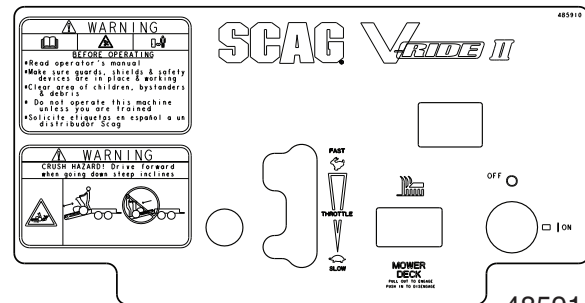

485911

SPECIFICATIONS

3.1 ENGINE

General TypeHeavy Duty Industrial/Commercial Gasoline

Model:

- Scag Model SVRII-36A-15FS.....Kawasaki FS541V
- Scag Model SVRII-36A-19FX.....Kawasaki FX600V
- Scag Model SVRII-48V-22FX.....Kawasaki FX691V
- Scag Model SVRII-52V-23FX.....Kawasaki FX730V
- Scag Model SVRII-52V-25CV-EFI..... Kohler ECV740
- Scag Model SVRII-61V-25FX.....Kawasaki FX801V
- Scag Model SVRII-61V-29CV-EFI..... Kohler ECV860

Displacement:

- Kawasaki FS541V 603cc
- Kawasaki FX600V 603cc
- Kawasaki FX690V 726cc
- Kawasaki FX730V 726cc
- Kohler ECV740..... 747cc
- Kohler ECV860..... 824cc
- Kawasaki FX801V 852cc

Cylinders..... 2 with Cast-Iron Sleeves

Governor..... Mechanical Type with Variable Speed Control Set At 3600 RPM (+/- 100 RPM)

Idle Speed:

- Kawasaki 1550 RPM (+/- 150 RPM)
- Kohler 1800 RPM (+/- 75 RPM)

Fuel..... Non-Leaded Gasoline with a Minimum Octane Rating of 87

Oil Pump..... Varies - see engine manufacturer's specifications

Starter:

- Kawasaki FS Recoil Start
- Kawasaki FX Electric Starting with solenoid shift starter
- Kohler ECV..... Electric Starting with solenoid shift starter

3.2 ELECTRICAL

Kawasaki FS Starter..... Electric Starting with Bendix Shift Starter or Electrical Ignition with Recoil Starter

Kohler & Kawasaki FX Starter Electric Starting with Solenoid Shift Starter

Interlock Switches..... Operator Presence, Mower Engagement (BBC), Parking Brake

Instrument Panel Tiger Eye Advanced Monitoring System, Key Switch, Throttle Lever, Choke Lever, PTO Switch

3.3 ENGINE DECK

Drive System Hydraulic Drive with Two Variable Displacement Pumps
and Two Cast-Iron High Torque Wheel Motors

Hydraulic Pumps Two Hydro-Gear PG Series 10 cc. (36) or PK Series 12 cc. (48 / 52 / 61)

Hydraulic Pumps (PK equipped with Fans) with Dump Valves for movement without the engine running

Hydraulic Drive Motors Two Parker Model TJ Cast-Iron Wheel Motors

Steering/Travel Control Twin Lever Steering Control with Individual Control to Each Wheel

Parking Brake Lever Actuated Linkage to Brakes on Both Drive Wheels

Wheels:

- (2) Front Caster (36) - 11 x 4-5 Flat Free w/Roller Bearings
(48 / 52 / 61) - 13 x 6.50 - 6 Flat-Free w/Roller Bearings
- (2) Drive - (36) 20 x 10 - 8 Four-Ply Pneumatic Tubeless, Radius Edge
(48 / 52 / 61) 24 x 9.5 - 8 Four-Ply Pneumatic Tubeless, Radius Edge

Tire Pressure:

- Front Caster..... Flat-Free
- Drive 12 PSI

Fuel Tank 6-3/4 Gallon (36) or 8 Gallon (48 / 52 / 61) Seamless Polyethylene Tank with Large Opening, Fuel Cap and Fuel Gauge

Travel Speed:

Forward (36) - 0 up to 8.5 MPH
 (48 / 52 / 61) - 0 up to 10.5 MPH

Reverse 0 up to 5.0 MPH

-NOTE- The machine will travel at speeds up to 8.5 mph, 10 mph or 10.5 mph for transport purposes. For best cutting performance the forward travel speed should be adjusted depending upon the cutting conditions.

3.4 CUTTER DECK

Type Out-Front design with anti-scalp rollers

Construction Tri-plate deck construction

Top of deck consists of three steel plates totaling nearly 1/2" of steel, 7-gauge (3/16") deck skirt

True Cutting Width:

36 35.5" (90.2 cm)

48 48" (122.0 cm)

52 52" (132.0 cm)

61 61" (155.0 cm)

Cutting Height Adjustment..... Adjustment from, 1-1/2" to 4-1/2" in 1/4" increments

Cutter Blades..... 0.197 in. Thick, Milled Edge, Wear Resistant Marbain™

Blade Engagement..... Electric Blade Engagement Clutch with Control Panel Switch
 Connected to the Cutter Deck through a Belt

Discharge Opening..... Extra Wide Discharge Opening with Spring-Loaded Discharge Chute

Discharge Chute..... Black, Polypropylene (Plastic), Flexible

Spindles..... Cast-Iron Housing, Tapered Roller Bearings with Top Access
 Grease Fitting and Grease Overfill Relief Poppet

Spindle Pulleys..... Split Steel with Tapered Locking Hub

Cutter Deck Belts..... B-section with Kevlar Cords

Electric Clutch Type Ogura Heavy Duty PTO Clutch Brake

3.5 WEIGHTS AND DIMENSIONS

	36	48 / 52	61V
Length	65-1/4"	67-1/2" / 69-1/2"	72-3/4"
Tracking Width	36"	48"	48"
Overall Width w/chute down	47-3/4"	61-1/4" / 65-1/4"	73-1/2"
Overall Width w/chute up.....	37-1/4"	49-3/4" / 53-3/4"	62-3/4"
Overall Height.....	47"	47-1/4"	47-1/4"
Operating Weight.....	832#	1015# / 1031#	1135#

3.6 PRODUCTIVITY

	36	48 / 52	61
Cutting Width	36"	48" / 52"	61"
Acres Per Day	14	18.6 / 20.2	23.7

The preceding chart will aid you in determining how many acres your Scag mower will cut per day. The chart is an estimate based on 8 hours per day cutting time at 6 MPH with a 20% allowance for overlap and turns.

OPERATING INSTRUCTIONS

WARNING

Do not attempt to operate this mower unless you have read this manual. Learn the location and purpose of all controls and instruments before you operate this mower.

Before operating the mower, familiarize yourself with all mower and engine controls. Knowing the location, function and operation of these controls is important for safe and efficient operation of the mower.

Tiger Eye Advanced Monitoring System is standard equipment on all SVR11-48V, SVR11-52V and SVR11-61V models only. With the key in the on position, before starting the engine, the lights for the Operator Indicator, PTO Indicator, Neutral Indicator and Park Brake Indicator should be illuminated. This indicates there is an operator on the platform, the PTO is off, steering levers are in neutral, and the parking brake is applied. When all the lights are illuminated, the key can be turned to the start position and the mower can be started. See Section 4.3 Safety Interlock System. If any of these indicator lights are not illuminated, the engine will be prevented from starting. If additional information or service is needed, contact your Scag Power Equipment Dealer.

4.1 TIGER EYE INSTRUMENT IDENTIFICATION (EXCLUDES SVR11-36A)

1. **Service Air Filter Indicator (Figure 4-1). Optional Accessory.** Indicates the condition of the engine air filter. Icon will display when it is time to change the air filter.
2. **Glow Plug Indicator (Figure 4-1). Used on Diesel Powered Units Only.** Indicator turns on when the key switch is turned to the PREHEAT position. Glow plugs must be preheated for 5 to 10 seconds before starting the engine.
3. **Oil Pressure Indicator (Figure 4-1). Used on Diesel Powered Units Only.** Indicates engine oil pressure. Reference the engine operator's manual for further information.
4. **Service Engine Indicator (Figure 4-1).** Indicates the maintenance reminder for the engine oil change. Has preset maintenance reminder and will start flashing scheduled maintenance 2 hours before preset time and continue flashing until 2 hours after. Automatically resets.
5. **Voltmeter Indicator (Figure 4-1).** Indicates the condition of the charging system. When the engine is running, in normal operating conditions, the bar graph should be in the 12 to 14 volt range.
6. **Operator Indicator (Figure 4-1).** Light will illuminate when the operator is on the platform engaging the operator presence switch.
7. **PTO Indicator (Figure 4-1).** Light will illuminate when the PTO (mower deck) switch is in the OFF position.
8. **Hourmeter Indicator (Figure 4-1).** Indicates the number of hours the engine has been operated. It only operates when the engine is running. Will start flashing with the Service Engine Indicator at scheduled maintenance 2 hours before preset time and continue flashing until 2 hours after. Automatically resets.
9. **Neutral Indicator (Figure 4-1).** Light will illuminate when the steering control levers are in the neutral lock position.
10. **Park Brake Indicator (Figure 4-1).** Light will illuminate when the park brake is in the engaged (ON) position.
11. **Water Temperature Indicator (Figure 4-1). Used on Liquid Cooled Models Only.** Indicates the operating temperature of the engine. If the engine temperature exceeds the maximum preset value, the indicator will flash and the Park Brake, PTO, Seat and Neutral indicator lights will flash in an alternating pattern.

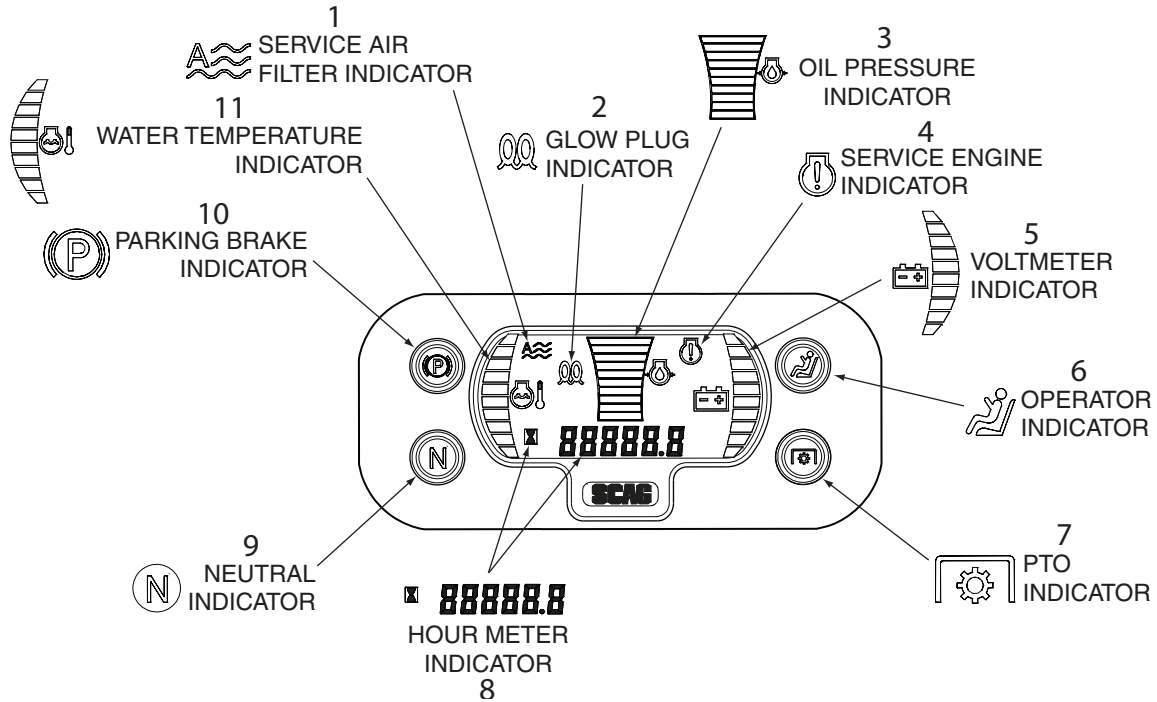

Figure 4-1. Tiger Eye Advanced Monitoring System

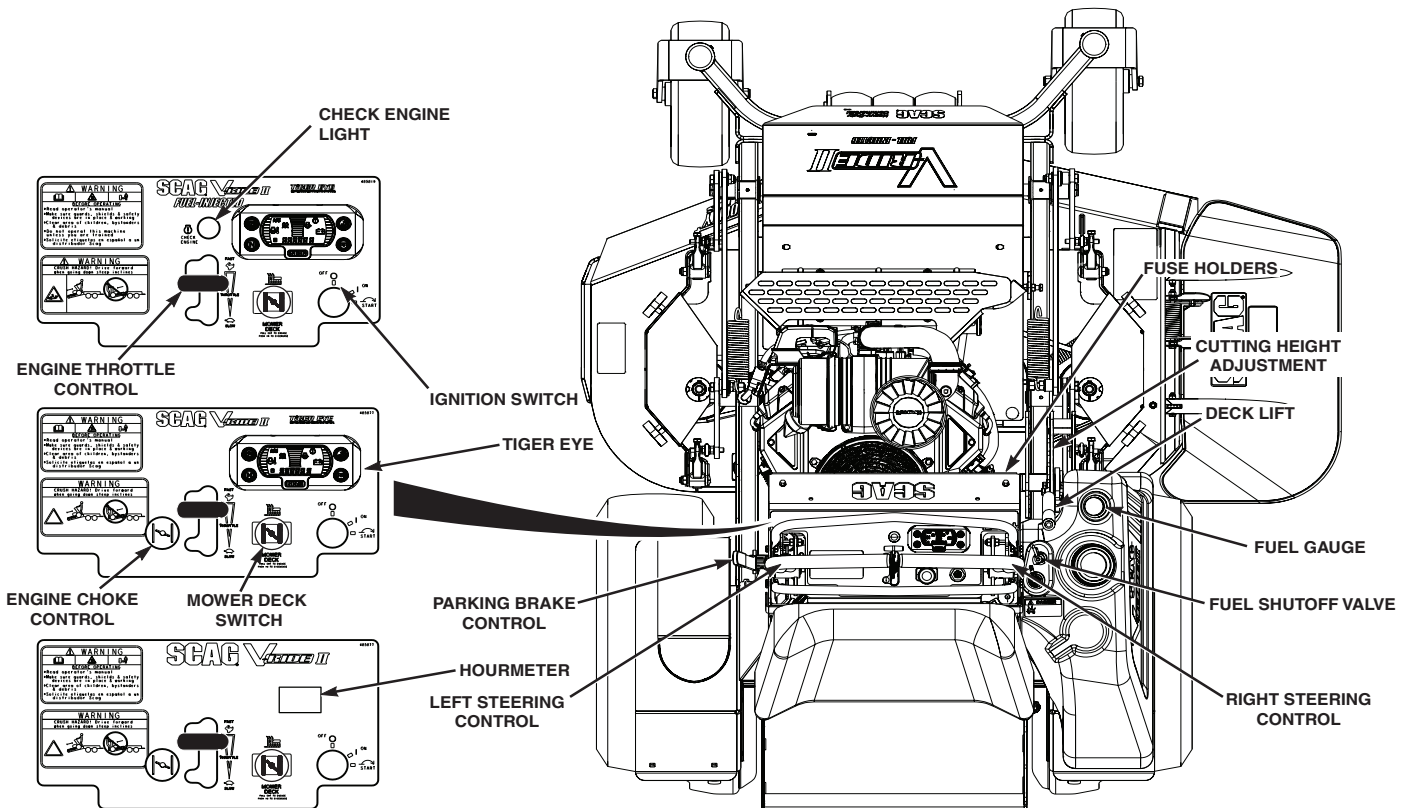

Figure 4-2. Controls and Instruments

Section 4

4.2 CONTROLS IDENTIFICATION

1. **Ignition Switch (Figure 4-2).** For electric start models, the ignition switch is used to start the engine and has three positions; OFF, ON, and START. For recoil start models, turn the key to the on position before pulling the recoil starter.
2. **Mower Deck Switch (Figure 4-2).** Used to engage and disengage the mower drive system. Pulling up on the switch will engage the deck drive. Pushing down on the switch will disengage the deck drive.
3. **Engine Choke Control (Figure 4-2).** Used to start a cold engine.
4. **Engine Throttle Control (Figure 4-2).** Used to control the engine speed. Pushing the lever forward increases engine speed. Pulling the lever back decreases engine speed. Full back position is the IDLE position. Full forward is the cutting position.
5. **Check Engine Light (Figure 4-2).** Indicates the operation of the engine sensors on the Fuel Injection Engines (EFI). If a problem occurs with a sensor on the engine, the light will flash a code. See your authorized Scag Dealer for diagnosis and repair.
6. **Left Steering Control (Figure 4-2).** Used to control the mower's left wheel when traveling forward or reverse. See Section 4.5 for further details regarding the mower's travel controls.
7. **Right Steering Control (Figure 4-2).** Used to control the mower's right wheel when traveling forward or reverse. See Section 4.5 for further details regarding the mower's travel controls.
8. **Parking Brake Control (Figure 4-2).** Used to engage and disengage the parking brakes and lock the steering handles in neutral. Pull the lever back to engage the parking brakes. Push the lever forward to disengage the parking brakes.
9. **Deck Lift Lever (Figure 4-2).** Used to raise and lower the cutter deck.
10. **Cutting Height Adjustment (Figure 4-2).** Used to set the cutter deck at the desired cutting height.
11. **Fuel Tank Gauge (Figure 4-2).** Indicates the amount of fuel in the fuel tank.
12. **Fuse Holders (Figure 4-2).** Two 20-amp fuses protect the mower's electrical system. To replace fuses, pull fuse out of the socket and install a new fuse.

13. **Hourmeter (Figure 4-2) SVR11-36A Only.** Indicates the number of hours the engine has been operated. It operates whenever the engine is running. Has preset maintenance reminders for engine and hydraulic system oil changes. Will start flashing scheduled maintenance 2 hours before preset time and continue flashing until 2 hours after. Automatically resets
14. **Fuel Shutoff Valve (Figure 4-2).** Located on top of the fuel tank. Used to shut off fuel supply to the engine. Rotate the valve counter clockwise to supply fuel from the tank to the engine. Rotate the valve clockwise to shut off the fuel supply to the engine.
15. **Dump Valve Controls (Figure 4-3).** Located on the hydraulic pumps, used to "free-wheel" the mower. Rotating clockwise until they stop allows the unit to move under hydraulic power. The levers must be in this position and torqued to 7-10 lb-ft during operation of the mower. Rotating counter-clockwise allows the mower to be moved by hand (free-wheeling). See Figure 4-3.

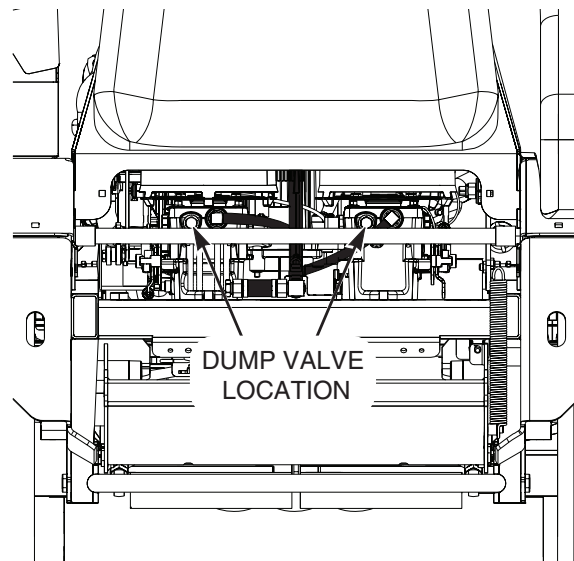

Figure 4-3. Dump Valve Controls

4.3 SAFETY INTERLOCK SYSTEM

The mower is equipped with a safety interlock system intended to protect the operator and others from injury. This is accomplished by preventing the engine from starting unless the deck drive is disengaged, the parking brake is engaged, the steering control levers are in the neutral position and the operator is in the operator position. The interlock system shuts off the engine if the operator leaves the operator platform with the steering control levers not in the neutral position and/or the cutter blades engaged and the parking brake not engaged.

WARNING

Never operate the mower with the interlock system disconnected or malfunctioning. Do not disengage or bypass any switch; injury to yourself and others or property damage could result.

4.4 INITIAL RUN-IN PROCEDURES

FIRST DAY OF USE OR APPROXIMATELY 20 HOURS

1. Check all belts for proper alignment and wear at 2, 4 and 8 hours.
2. Change the engine oil and oil filter after the first 20 hours of operation. See Section 7.4.
3. Check oil level in the hydraulic system reservoir. See Section 7.3.
4. Check for loose hardware. Tighten as needed.
5. Check interlock system for proper operation. See Section 4.2.
6. Check tire pressure. Adjust pressure if necessary. See Section 7.10.

4.5 STARTING THE ENGINE

CAUTION

DO NOT USE STARTING FLUIDS. Use of starting fluids in the air intake system may be potentially explosive or cause a “runaway” engine condition that could result in engine damage and/or personal injury.

1. Be sure the fuel shutoff valve, located by the fuel tank, is completely open. See Section 7.5.
2. Place the steering control levers in the neutral position and disengage the cutter blades.
3. Engage the parking brake.
4. If the engine is cold, choke the engine as needed.
5. Move the engine throttle control to about half engine speed.
6. Turn the ignition key to the start position and start the engine.

7. Allow engine to warm before operating the mower.

4.6 GROUND TRAVEL AND STEERING

- IMPORTANT -

If you are not familiar with the operation of a machine with lever steering and/or hydrostatic transmissions, the steering and ground speed operations should be learned and practiced in an open area, away from buildings, fences, or obstructions. Practice until you are comfortable with the handling of the machine before attempting to mow. Learn the operation on flat ground before operating on slopes.

- IMPORTANT -

Start practicing with a slow engine speed and slow forward travel.

Learn to feather the steering controls to obtain a smooth operating action.

Practice operating the mower until you are comfortable with the controls before proceeding to mow.

FORWARD TRAVEL

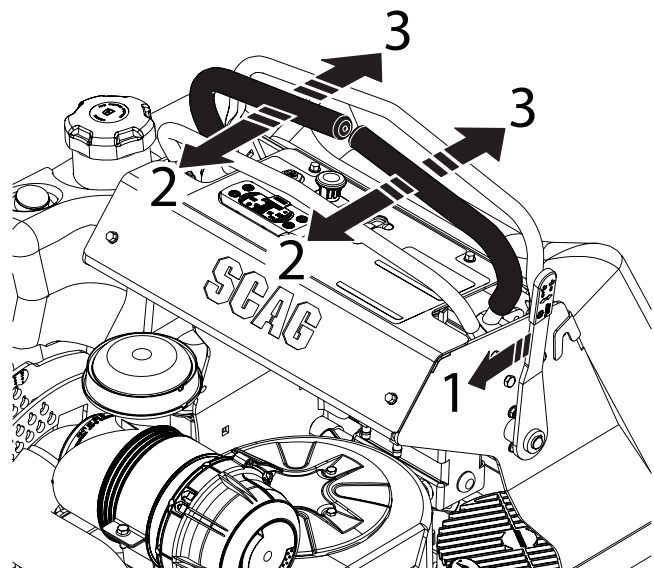

Figure 4-4. Travel Controls

1. Release parking brake.
2. Forward travel.
3. Reverse travel.

Section 4

To travel forward with the mower, disengage the parking brake, place your hands on the steering control levers and slowly push the levers forward an equal distance. The further the steering control levers are pushed forward, the greater the forward speed will be. To increase the speed, push the steering control levers forward and to decrease speed, pull the steering control levers back. See Figure 4-4.

To stop the forward travel completely, pull the steering control levers back to the neutral position.

To steer the mower to the left while traveling forward, pull the left steering control lever back. The further the steering control is pulled back, the quicker the mower will turn left.

To steer the mower to the right while traveling forward, pull the right steering control lever back. The further the steering control is pulled back, the quicker the mower will turn right.

- NOTE -

Smooth operation of the steering control levers will produce smooth mower operation. While learning the operation of the steering controls, keep the travel speed low.

- IMPORTANT -

Do not travel forward over a curb. The mower will hang up on the curb. Raise the deck and travel backwards over the curb at a 45 degree angle. (See Figure 4-1 item 9 for cutter deck raising description.)

REVERSE TRAVEL

CAUTION

Disengage power to the mower before backing up. Do not mow in reverse unless absolutely necessary and then only after observation of the entire area behind the mower.

CAUTION

Before backing up, observe the rear for persons and obstructions. Clear the area before backing up. Possible injury or property damage could occur.

To travel in reverse, pull both steering control handles back. Keep the travel speed low while traveling in reverse.

- NOTE -

The mower may not travel straight in reverse. Slight adjustments may need to be made using the steering controls.

To steer left while traveling in reverse, allow the left steering control lever to move forward. The further the control is allowed to move forward, the quicker the mower will turn left.

To steer right while traveling in reverse, allow the right steering control lever to move forward. The further the control is allowed to move forward, the quicker the mower will turn right.

To stop the reverse travel, allow the steering control levers to return to the neutral position. If the mower is to be parked, engage the parking brake.

4.7 ENGAGING THE DECK DRIVE (CUTTER BLADES)

1. Set the throttle at about 3/4 speed. Do not attempt to engage the deck drive at high speed as this shortens the electric clutch life — use only moderate engine speed when engaging the deck drive.
2. Engage the deck drive by pulling out on the yellow switch, located on the instrument panel, to the engage position. See Figure 4-5.

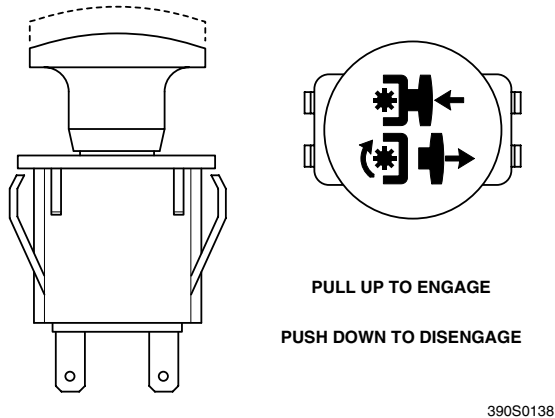

Figure 4-5. Cutter Engage Switch

4.8 HILLSIDE OPERATION

WARNING

DO NOT operate on steep slopes. Under no circumstances should the machine be operated on slopes greater than 20 degrees. See Figure 2-1, Page 5 to determine approximate slope of area to be mowed. **ALWAYS FOLLOW OSHA APPROVED OPERATION.**

1. This mower has been designed for good traction and stability under normal mowing conditions. However, caution must be used when traveling on slopes, especially when the grass is wet. Wet grass reduces traction and steering control.
2. Stay two cut widths away from slopes, drop offs, ditches and retaining walls.
3. To prevent tipping or loss of control, do not start or stop suddenly, avoid unnecessary turns and travel at reduced speed. If tires lose traction, disengage blades and proceed slowly off the slope.
4. Avoid sudden starts when mowing uphill. Sudden starts may cause the machine to tip backwards.
5. Loss of traction may occur when traveling down hill. Weight transfers to the front of the machine and may cause the drive wheels to slip causing loss of braking or steering.
6. Never back down hill.
7. Keep tires properly inflated.

CAUTION

Disengage power to the mower before backing up. Do not mow in reverse unless absolutely necessary and then only after observation of the entire area behind the mower.

CAUTION

Before backing up, observe behind the mower for persons and obstructions. Clear the area before backing up. Possible injury or property damage could occur.

- NOTE -

A squealing noise may be heard when engaging or disengaging the deck drive. It is caused by the electric clutch plates meshing as the mower comes up to speed. This is normal.

3. To disengage the deck drive, push the switch in to the disengage position.
4. Always operate the engine at full throttle to properly maintain cutting speed. If the engine starts to lug down, reduce the forward speed and allow the engine to operate at maximum RPM.

4.9 PARKING THE MOWER

1. Park the machine on a flat, level surface only. Do not park the machine on an incline.
2. Place the steering control levers in the neutral position.
3. Disengage the cutter blades.
4. Slow the engine to idle speed.
5. Engage the parking brake.
6. Turn the ignition key to the OFF position and remove the key.

Section 4

4.10 AFTER OPERATION

1. Wash the entire mower after each use. Do not use high pressure spray or direct the spray onto electrical components.

- IMPORTANT -

Do not wash a hot or running engine. Cold water will damage the engine. Use compressed air to clean the engine if it is hot.

2. Keep the entire mower clean to inhibit serious heat damage to the engine or hydraulic oil circuit.
3. Check the drive belts for proper alignment and any signs of wear. Correct and adjust if necessary.

DANGER

To avoid injury from burns, allow the mower to cool before removing the fuel tank cap and refueling.

4. After the mower has cooled down, fill the fuel tank with fresh, clean fuel at the end of every day of operation. See Engine Owner's Manual for proper octane requirements.
5. Check the tire pressure. Adjust pressure if necessary.

4.11 REMOVING CLOGGED MATERIAL

DANGER

ROTATING BLADES

NEVER PUT YOUR HANDS INTO THE DISCHARGE CHUTE FOR ANY REASON!

Shut off the engine and remove the key and only then use a stick or similar object to remove material if clogging has occurred.

1. If the discharge chute becomes clogged, shut off the engine and remove the ignition key. Using a stick or similar item, dislodge the clogged material. Then resume normal mowing.

4.12 MOVING MOWER WITH ENGINE STOPPED

To “free-wheel” or move the mower around without the engine running, place the dump valve levers in the FREE-WHEEL position. Disengage the parking brake and move the mower by hand. The dump valve levers must be returned to the DRIVE position and torqued to 7-10 ft/lbs to drive the mower.

4.13 RECOMMENDATIONS FOR MOWING

1. Do not mow with dull blades. A dull blade will tear grass, resulting in poor lawn appearance and reduced mowing power.

WARNING

DO NOT operate without Discharge Chute, Mulching Kit, Operator Controlled Discharge Chute (OCDCh) or entire Grass Catcher properly installed.

2. The discharge chute must not be removed and must be kept in the lowest position to deflect grass clippings and thrown objects downward. Direct the side discharge away from sidewalks or streets to minimize cleanup of clippings. When mowing close to obstacles, direct the discharge away from the obstacles to reduce the chance of property damage by thrown objects.
3. Cut grass when it is dry and not too tall. Do not cut grass too short (cut off 1/3 or less of existing grass for best appearance). Mow frequently.
4. Keep mower and discharge chute clean.
5. When mowing wet or tall grass, mow the grass twice. Raise the mower to the highest setting for the first pass and then make a second pass to the desired height.
6. Use a slow travel speed for trimming purposes.
7. Operate the engine at full throttle for best cutting. Mowing with a lower RPM causes the mower to tear the grass. The engine is designed to be operated at full speed.
8. Use the alternate stripe pattern for best lawn appearance. Vary the direction of the stripe each time the grass is mowed to avoid wear patterns in the grass.

4.14 ADJUSTING CUTTING HEIGHT

The mower deck can be adjusted from a height of 1-1/2 inch to 4-1/2 inches at 1/4-inch intervals. To adjust the cutting height:

WARNING

DO NOT adjust the cutting height with the mower blades rotating. Disengage the power to the cutter blades, put the steering control levers in the neutral position, apply the parking brake and then adjust cutting height.

1. Disengage the power to the cutter blades.
2. Pull on the cutter deck lift lever all the way backward until it locks in place. See Figure 4-6.
3. Insert the lanyard pin into the cutting height index at the desired cutting height. Pull backward on the cutter deck lift lever, push and hold the lock button. See Figure 4-6. Slowly release the cutter deck lift lever. A deck height decal is located on the cutting height index as an aid in adjusting the deck to the desired height.

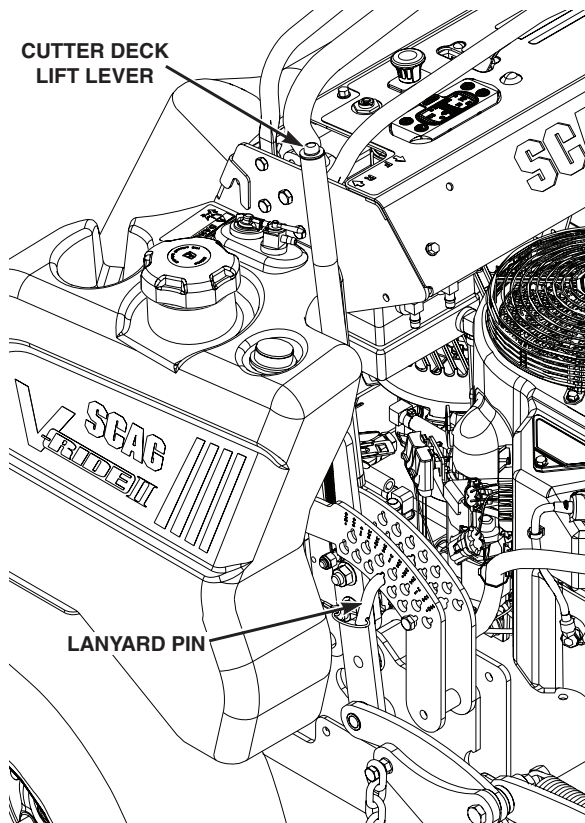
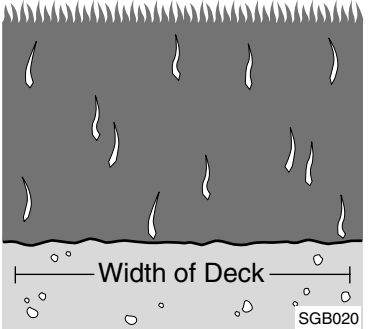
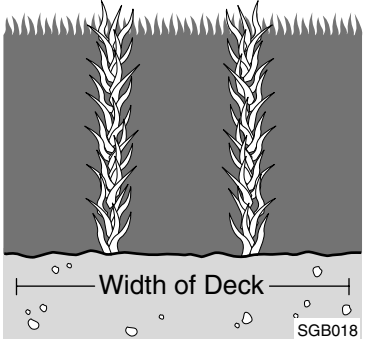
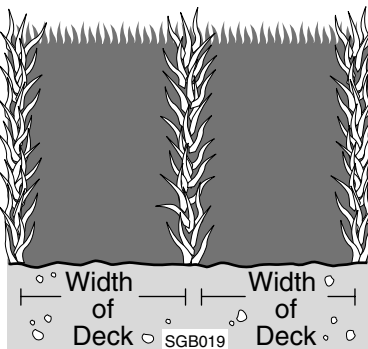
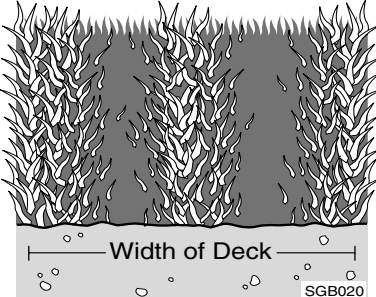
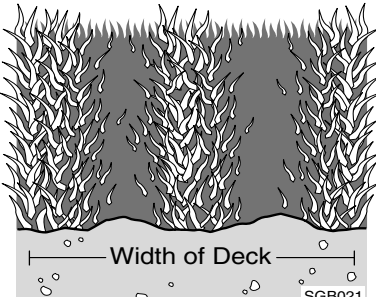
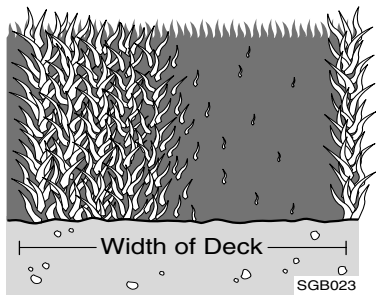

Figure 4-6. Adjusting Cutting Height

TROUBLESHOOTING CUTTING CONDITIONS

CONDITION	CAUSE	CURE
<p>STRINGERS - OCCASIONAL BLADES OF UNCUT GRASS</p> 	Low engine RPM	Run engine at full RPM
	Ground speed too fast	Slow speed to adjust for conditions
	Wet grass	Cut grass after it has dried out
	Dull blades, incorrect sharpening	Sharpen blades
	Deck plugged, grass accumulation	Clean underside of deck
	Belts slipping	Adjust belt tension
<p>STREAKING - STRIPS OF UNCUT GRASS IN CUTTING PATH</p> 	Dull, worn blades	Sharpen blades
	Incorrect blade sharpening	Sharpen blades
	Low engine RPM	Run engine at full RPM
	Belt slipping	Adjust belt tension
	Deck plugged, grass accumulation	Clean underside of deck
	Ground speed too fast	Slow speed to adjust for conditions
	Wet grass	Cut grass after it has dried out
	Bent blades	Replace blades
<p>STREAKING - STRIPS OF UNCUT GRASS BETWEEN CUTTING PATHS</p> 	Not enough overlapping between rows	Increase the overlap of each pass

TROUBLESHOOTING CUTTING CONDITIONS (CONT'D)

CONDITION	CAUSE	CURE
<p>UNEVEN CUT ON FLAT GROUND - WAVY HIGH-LOW APPEARANCE, SCALLOPED CUT, OR ROUGH CONTOUR</p>  <p style="text-align: right; font-size: small;">SGB020</p>	Lift worn from blade	Replace blade
	Blade upside down	Mount with cutting edge toward ground
	Deck plugged, grass accumulation	Clean underside of deck
	Too much blade angle (deck pitch)	Adjust pitch and level
	Deck mounted improperly	See your authorized SCAG dealer
	Bent spindle area	See your authorized SCAG dealer
	Dull blade	Sharpen blade
<p>UNEVEN CUT ON UNEVEN GROUND-WAVY APPEARANCE, HIGH-LOW SCALLOPED CUT, OR ROUGH CONTOUR</p>  <p style="text-align: right; font-size: small;">SGB021</p>	Uneven ground	May need to reduce ground speed, raise cutting height, and/or change direction of cut
<p>SLOPING RIDGE ACROSS WIDTH OF CUTTING PATH</p>  <p style="text-align: right; font-size: small;">SGB023</p>	Tire pressures not equal	Check and adjust tire pressure
	Wheels uneven	Check and adjust tire pressure
	Deck mounted incorrectly	See your authorized SCAG dealer
	Deck not level side-to-side	Check for level and correct

TROUBLESHOOTING CUTTING CONDITIONS (CONT'D)

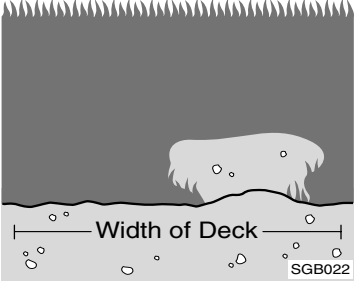
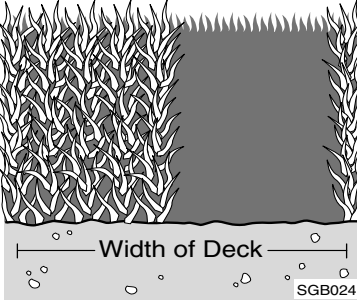
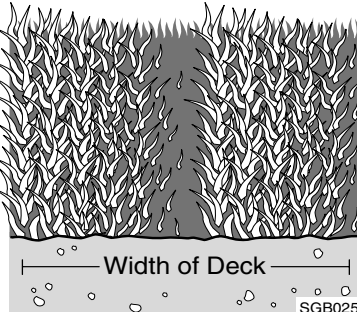
CONDITION	CAUSE	CURE
<p>SCALPING - BLADES HITTING DIRT OR CUTTING VERY CLOSE TO THE GROUND</p> 	Low tire pressures	Check and adjust pressures
	Ground speed too fast	Slow speed to adjust for conditions
	Cutting too low	May need to reduce ground speed, raise cutting height, change direction of cut, and/or change pitch and level
	Rough terrain	May need to reduce ground speed, raise cutting height, and/or change direction of cut
	Ground speed too fast	Slow speed to adjust for conditions
	Wet grass	Cut grass after it has dried out
<p>STEP CUT - RIDGE IN CENTER OF CUTTING PATH</p> 	Blades not mounted evenly	Adjust pitch and level
	Bent blade	Replace blade
	Internal spindle failure	See your authorized SCAG dealer
	Mounting of spindle incorrect	See your authorized SCAG dealer
<p>SLOPE CUT - SLOPING RIDGES ACROSS WIDTH OF CUTTING PATH</p> 	Bent spindle mounting area	See your authorized SCAG dealer
	Internal spindle failure	See your authorized SCAG dealer
	Bent deck housing	See your authorized SCAG dealer

ADJUSTMENTS

6.1 PARKING BRAKE ADJUSTMENT

WARNING

DO NOT operate the mower if the parking brake is not operable. Possible severe injury could result.

The parking brake should be adjusted whenever the parking brake lever is placed in the “ENGAGE” position and the parking brake will allow the mower to move. If the following procedures do not allow you to engage the parking brake properly, contact your Scag dealer for further brake adjustments.

1. Park the machine on a flat, level surface. Block the wheels to prevent the machine from moving.

CAUTION

Adjust the brake only enough to hold the machine. Excessive force may cause damage to the machine or brake components.

2. Release the parking brake lever.
3. Look for a gap (approximately 1/4") between the left side drive tire and the brake weldment. See Figure 6-1. Loosen the hardware securing the brake weldment to the brake actuator shaft weldment. Adjust the brake weldment until there is a 1/4" gap between the tire and brake weldment. Tighten the hardware
4. Repeat this procedure on the right side drive tire.

- NOTE -

If this procedure does not achieve proper brake adjustment, please contact your authorized Scag dealer.

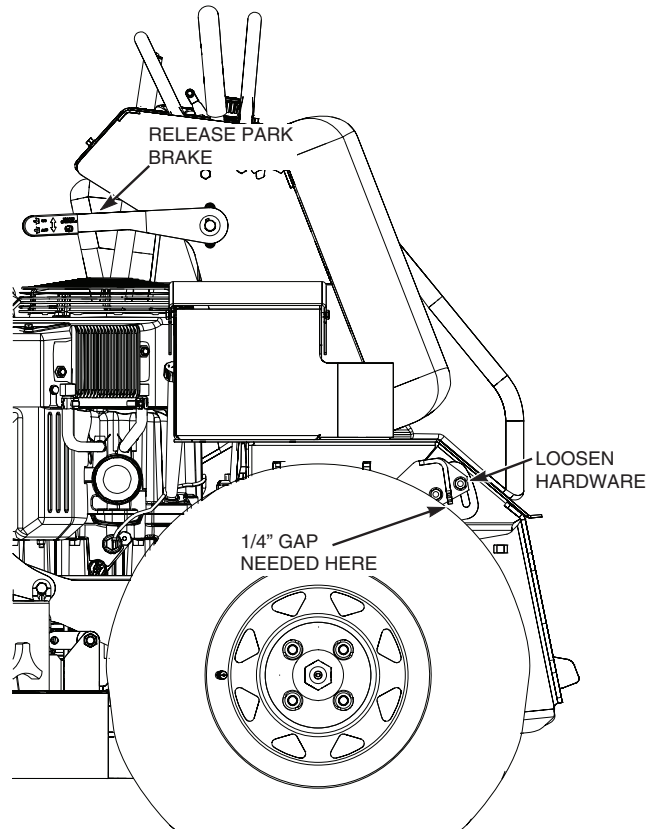

Figure 6-1. Brake Adjustment

6.2 TRAVEL ADJUSTMENT

Neutral or tracking adjustments will need to be made if:

1. The steering control is in the neutral position and the machine creeps forward or backward. (Neutral Adjustment)
2. The steering control is in the full forward position and the mower pulls to one side or the other when traveling in a forward position. (Tracking Adjustment)

Section 6

NEUTRAL ADJUSTMENT

-NOTE-

Neutral has been set by your Scag dealer at the time of set up and normally does not need to be adjusted. If, however, you find that the neutral has come out of adjustment, follow the procedure below.

1. Be sure the dump valves are in the run position and the steering control levers are in the neutral position.
2. With an operator in the operating position, park the machine on a flat level surface, start the engine and disengage the parking brake.
3. Run the engine at full operating speed and check if the machine creeps forward or backwards.
4. Adjust the LH wheel by loosening the jam nuts on the steering control rod and turning the rod until the drive wheel turns in the forward direction. Turn the rod back until the drive wheel stops moving. Turn the rod an additional 1/2 turn. See Figure 6-2.

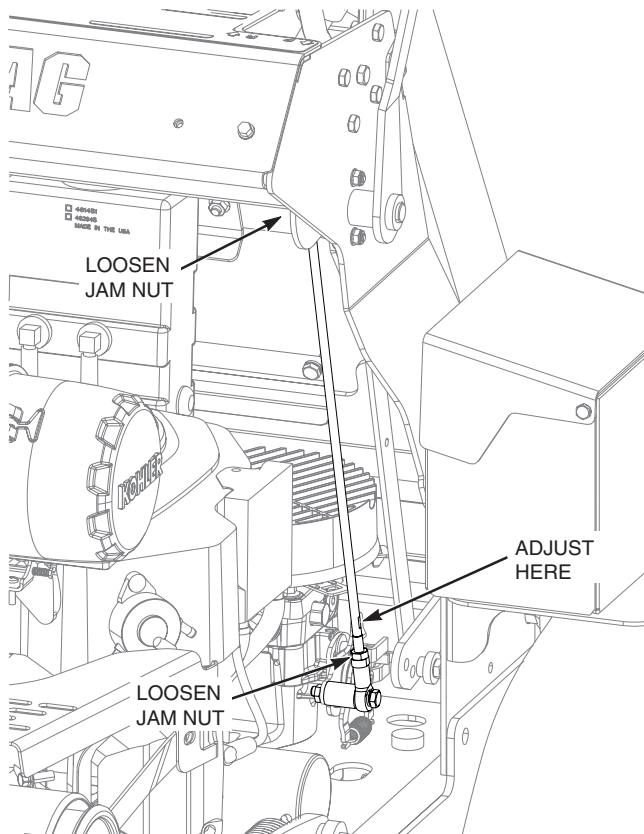

Figure 6-2. Tracking Adjustment (Left Side Shown)

5. Repeat for the RH wheel using the same adjustment procedure listed above.

6. Actuate the steering control levers forward and reverse several times and return them to the neutral position.
7. Check that the drive wheels remained in neutral and readjust if necessary.
8. Check that the steering control levers hit the stop before the pumps reach full stroke. Adjust as needed.

TRACKING ADJUSTMENT

! CAUTION

Stop the engine and remove the key from the ignition before making any adjustments. Wait for all moving parts to come to a complete stop before beginning work.

! CAUTION

The engine and drive unit can get hot during operation causing burn injuries. Allow the engine and drive components to cool before making any adjustments.

-NOTE-

Before proceeding with this adjustment, be sure that the caster wheels turn freely and that the tire pressure in the drive wheels is correct. If the tire pressure is not correct, the machine will pull to the side with the lower pressure.

1. If at full speed the mower pulls right, it is an indication that the left wheel is turning faster than the right wheel. To adjust this condition, proceed as follows:
 - A. Stop the machine and place the steering control levers in the neutral position. Loosen the lock nuts securing the ball joints at each end of the LH steering control rod. Rotate the control rod to lengthen the rod and tighten the lock nuts. This will cause the control rod to stroke the LH pump less, slowing down the LH wheel. See Figure 6-2.

- NOTE -

If after making the adjustment as outlined in step 1A, the machine creeps forward or backward, the neutral adjustment must be made as described on page 23.

2. If at full speed the mower pulls left, it is an indication that the right wheel is turning faster than the left wheel. To adjust this condition, proceed as follows:

A. Stop the machine and place the steering control levers in the neutral position. Loosen the lock nuts securing the ball joints at each end of the RH steering control rod. Rotate the control rod to lengthen the rod and tighten the lock nuts. This will cause the control rod to stroke the RH pump less, slowing down the RH wheel. The same adjustment is used for the RH side as shown in Figure 6-2.

- NOTE -

If after making the adjustment as outlined in step 2A, the machine creeps forward or backward, the neutral adjustment must be made as described on page 23.

6.3 THROTTLE CONTROL AND CHOKE ADJUSTMENTS

These adjustments must be performed by your Scag dealer to ensure proper and efficient running of the engine. Should either need adjustment, contact your authorized Scag service center.

6.4 BELT ADJUSTMENTS

 <h2 style="margin: 0;">WARNING</h2>
<p>Before removing any guards, shut the engine off and remove the ignition key. Wait for all moving parts to come to a complete stop before beginning work.</p>

All drive belts and cutter deck belts are spring loaded and self-tensioning. The belts should be checked periodically for proper alignment and wear.

 <h2 style="margin: 0;">WARNING</h2>
<p>If the pump drive belt fails, steering control will be lost which could result in serious injury or death. Replace the pump drive belt as needed or every 400 hours / 2 years, whichever occurs first.</p>

If the pump drive belt fails, steering control will be lost which could result in serious injury or death. Replace the pump drive belt as needed or every 400 hours / 2 years, whichever occurs first.

6.5 BELT ALIGNMENT

Belt alignment is important for proper performance of your Scag mower. If you experience frequent belt wear or breakage, see your authorized Scag service center for belt adjustment.

6.6 CUTTER DECK ADJUSTMENTS

Cutter deck level, pitch and height are set at the factory. However, if these adjustments should ever need to be made, the following procedures will aid in obtaining the proper cutter deck adjustment.

- NOTE -

Before proceeding with the cutter deck adjustments, be sure all tires are properly inflated.

CUTTER DECK LEVEL

The cutter deck should be level from side-to-side for proper cutting performance. To check for level, be sure that the mower is on a flat, level surface, the tires are properly inflated and the cutter deck is set at the most common cutting height that you will use. On the RH side of the machine, check the distance from the top of the cutter deck to the floor. Next check the distance from the top of the cutter deck to the floor on the LH side of the machine. Both measurements should be the same. If the two measurements are different, the cutter deck level must be adjusted as follows:

1. If the cutter deck is lower on one side, loosen the elastic stop nuts securing the deck level links on the front and rear of the lower side. See Figure 6-3.

Section 6

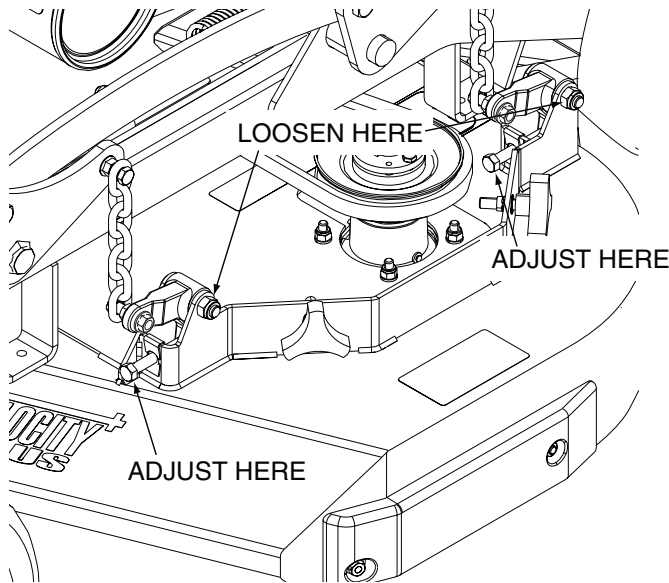

Figure 6-3. Cutter Deck Level Adjustment

2. Turn the adjustment bolts on the front and rear deck level links clockwise until the cutter deck is level between both sides. See Figure 6-3.
3. Tighten the two (2) elastic stop nuts to secure the cutter deck in the proper position.

CUTTER DECK PITCH

The pitch of the cutter deck should be equal between the front and rear of the cutter deck for proper cutting performance. To check for proper deck pitch, be sure that the mower is on a flat, level surface and the tires are properly inflated.

Check the distance from the top of the cutter deck to the floor at the rear RH side of the cutter deck directly behind the cutter deck hanging chains. Next check the distance from the top of the cutter deck to the floor at the front RH side of the cutter deck directly in front of the cutter deck hanging chains. The measurement at the front of the cutter deck should be the same as the rear of the deck. Make these measurements at the LH side of the cutter deck also. If the measurement at the front of the deck is not the same, the cutter deck pitch must be adjusted as follows:

1. Loosen the elastic stop nuts securing the deck level links on the front of the cutter deck on both sides. See Figure 6-4 and 6-5.

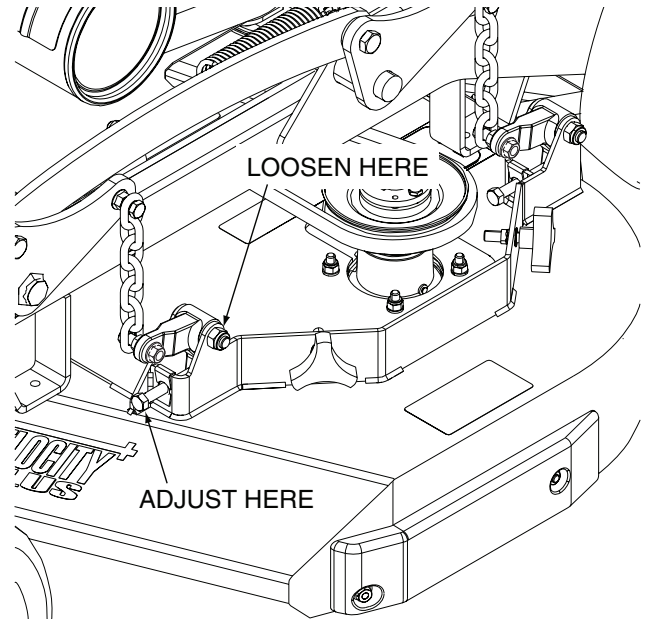

Figure 6-4. Cutter Deck Pitch Adjustment

2. Turn the adjustment bolts on both sides either clockwise to raise or counter-clockwise to lower the front of the cutter deck until the measurements are equal. Tighten the elastic stop nuts.

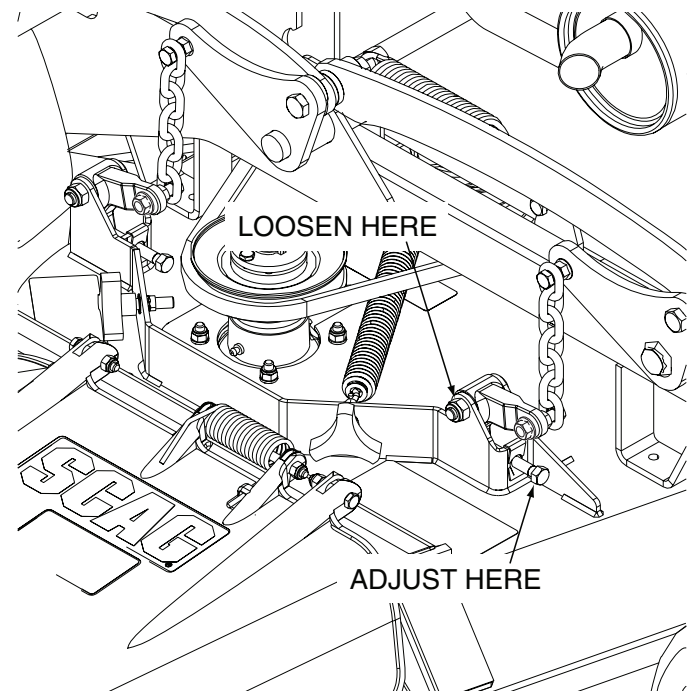

Figure 6-5. Cutter Deck Pitch Adjustment

- NOTE -

To prevent the cutter deck from teetering, all four (4) cutter deck hanging chains must have tension on them. If all four chains do not have tension on them and the deck teeters, you must re-adjust the cutter deck as outlined in the procedures above. All measurements should be taken from the top edge of the deck as the deck has an uneven bottom edge.

CUTTER DECK HEIGHT

The cutter deck height adjustment is made to ensure that the cutter deck is cutting at the height indicated on the cutting height index gauge. To check for proper deck height, be sure that the mower is on a flat, level surface, shut off the engine and remove the ignition key. Make sure the tires are properly inflated.

1. Check the cutter deck cutting height by placing the lanyard pin in the 3" position on the cutting height index. Release the deck from the transport position and allow the deck to move to the 3" cutting height position.
2. Rotate the cutter blade on the left side of the cutter deck. Position the cutter blade so it is facing "front to back" on the machine.

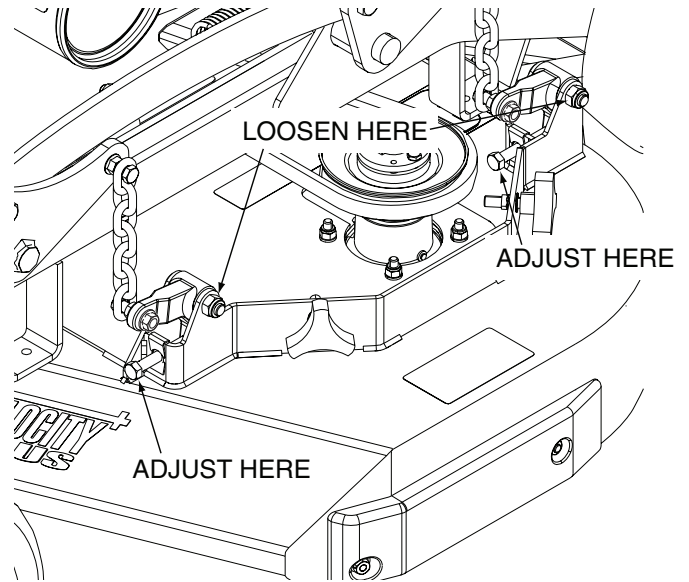

Figure 6-6. Left Side Cutter Deck Adjustment

4. Rotate the cutter blade on the right side of the cutter deck. Position the cutter blade so it is facing "front to back" on the machine.
5. Check the measurement from the floor to the cutter blade tip at the front and rear of the right side blade. If the measurement is not at 3", an adjustment must be made using the cutter deck adjustment lever. Adjust as follows:

A. Loosen the elastic stop nuts securing the deck level links on the front and rear of the cutter deck. See Figure 6-7.

B. Turn the adjustment bolts on the front and rear either clockwise to raise or counterclockwise to lower the cutter deck until the measurements are equal. Tighten the elastic stop nuts.

WARNING

Always wear proper hand and eye protection when working with cutter blades.

3. Check the measurement from the floor to the cutter blade tip at the front and rear of the left side blade. If the measurement is not at 3", an adjustment must be made using the cutter deck adjustment lever. Adjust as follows:
 - A. Loosen the elastic stop nuts securing the deck level links on the front and rear of the cutter deck. See Figure 6-6.
 - B. Turn the adjustment bolts on the front and rear either clockwise to raise or counterclockwise to lower the front of the cutter deck until the measurements are equal. Tighten the elastic stop nuts.

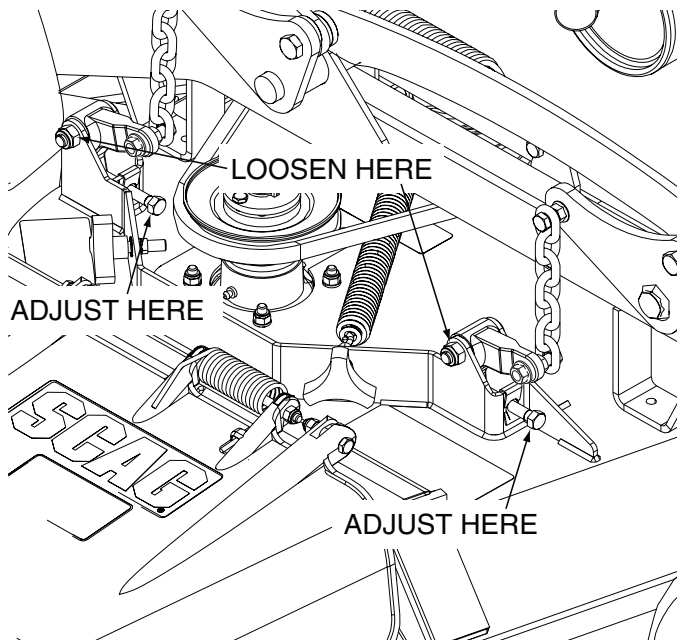

Figure 6-7. Right Side Cutter Deck Adjustment

This adjustment will set the cutter deck with no pitch. If a pitch in the cutter deck is desired, Cutter Deck Pitch Adjustment on Page 25.

CUSTOM-CUT BAFFLE ADJUSTMENT

The Custom-Cut Baffle is designed to deliver optimum airflow and superior cutting performance in any type of grass. The Custom-Cut Baffle can be raised or lowered to precisely tailor the deck's performance for the type of grass being cut. The baffle can be set in seven (7) different positions for optimum performance.

- A. 3-1/2" or 3-3/4" Position - See Figure 6-8. For very tall, wiry or tough-to-cut grass.
- B. 4" (factory setting), 4-1/4" or 4-1/2" Position - See Figure 6-8. For general purpose cutting. This gives the best mix of cutting performance in all types of grass.
- C. 4-3/4" or 5-1/4" Position - See Figure 6-8. Placing the baffle in either the 4-3/4" or 5-1/4" setting will enhance fall cutting (leaf pickup) and reduce cutter deck "blowout".

To adjust the Custom-Cut Baffle height:

1. Park the machine on a flat surface, apply the parking brake, shut off the engine and remove the key.
2. Place the cutter deck in the transport position.
3. Remove the hardware securing the Custom-Cut Baffle to the cutter deck.

- NOTE -

Hardware location used in the illustrations are for reference only. Location of hardware may vary depending on cutter deck size.

4. Move the Custom-Cut Baffle to desired position. See Figures 6-8.
5. Reinstall the mounting hardware. Torque hardware to 39 ft-lbs.

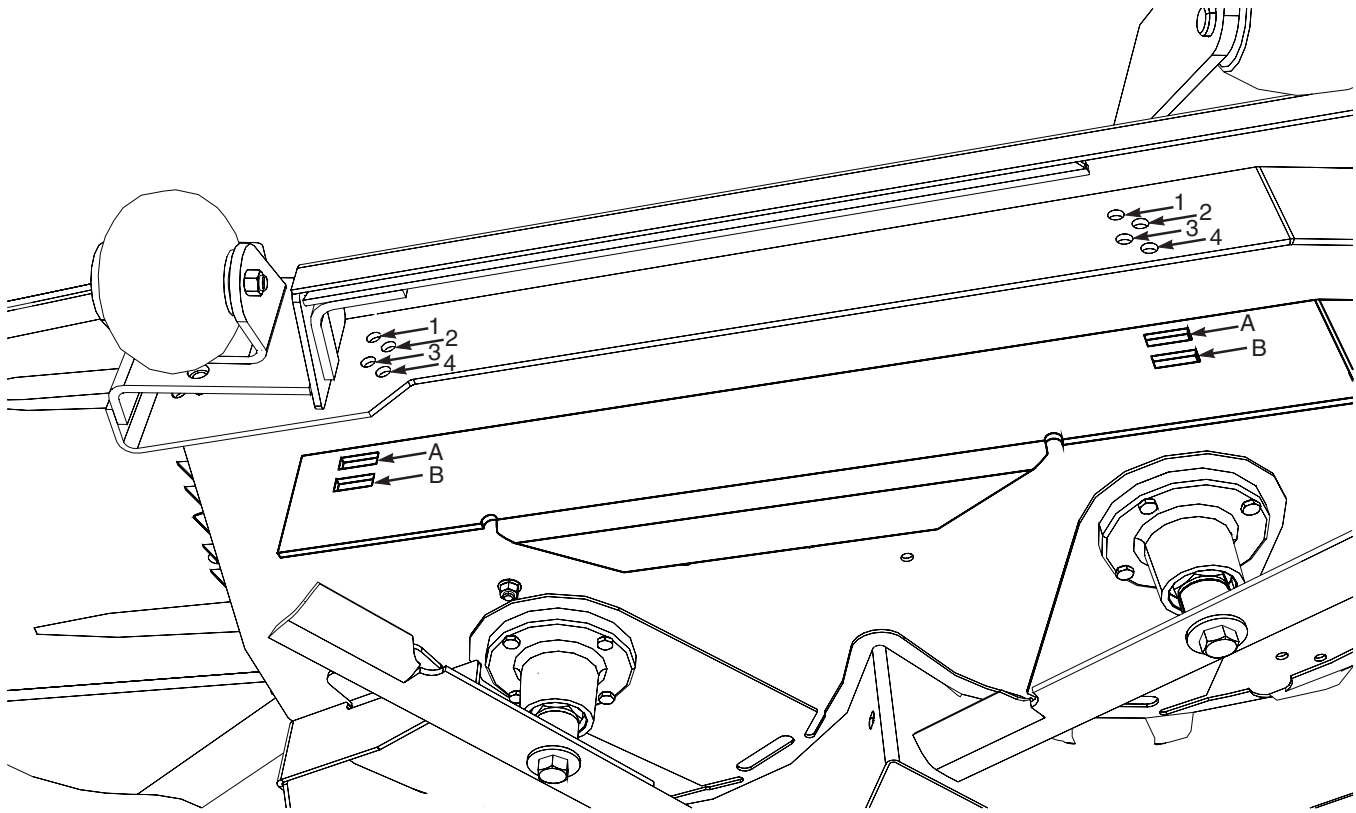

Custom-Cut Baffle Adjustment

Mounting Slot Selected	Mounting Hardware Location			
	Hole 1	Hole 2	Hole 3	Hole 4
Slot "A"				
Height (inches)	3-3/4"	4-1/4"	4-3/4"	5-1/4"
Slot "B"				
Height (inches)		3-1/2"	4"	4-1/2"

Figure 6-8. Custom-Cut Baffle Adjustment

Section 6

6.7 ELECTRIC CLUTCH ADJUSTMENT

The electric clutch serves two functions in the operation of the mower. In addition to starting and stopping the power flow to the cutter blades, the clutch also acts as a brake to assist in stopping blade rotation when the PTO is switched off or the operator presence circuit is interrupted.

When the clutch is disengaged, the air gap between the armature and rotor must be adjusted to fifteen thousandths of an inch, 0.015, for proper operation. The airgap adjustment is made at three bolts on the clutch. There are three inspection windows, one next to each adjusting bolt. See Figure 6-9.

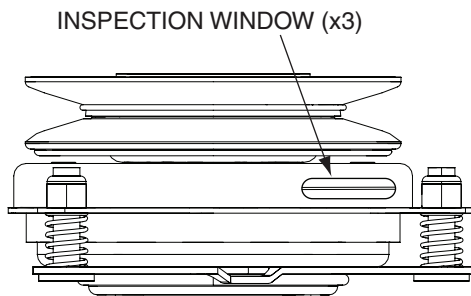

Figure 6-9. Clutch Air Gap Adjustment

1. Locate the inspection windows on the clutch.
2. Place a 0.015 feeler gauge in the slot between the rotor and the armature. See Figure 6-10.

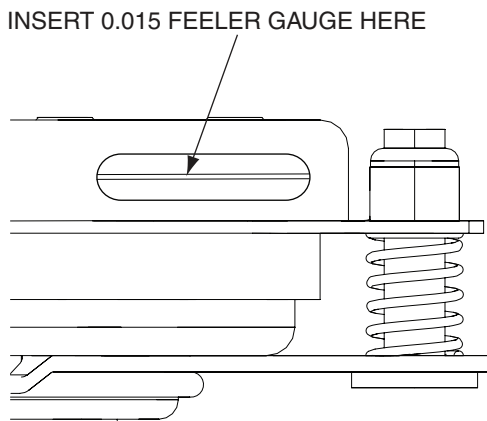

Figure 6-10. Clutch Air Gap Adjustment

3. Tighten or loosen the adjusting bolt as needed to achieve the 0.015 inch airgap. See Figure 6-11. Perform this operation at all three inspection windows.

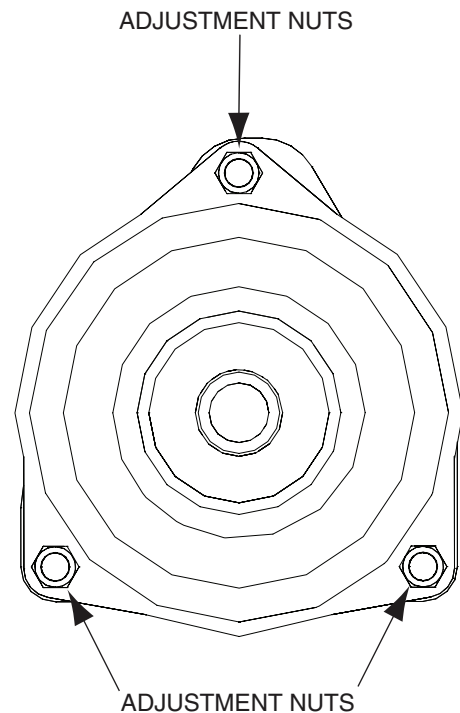

Figure 6-11. Clutch Air Gap Adjustment

This adjustment should be done every 500 hours of operation or annually, whichever comes first. In cases where the machine is heavily used, airgap settings should be checked more often.

If the air gap is too narrow, the clutch armature may drag when disengaged, resulting in premature failure.

If the air gap is too wide, the clutch may be slow to engage as the magnet must pull the armature in from a greater distance.

6.8 OPERATOR CUSHION AND REAR COVER REMOVAL

The operator cushion and rear cover can be easily removed to gain access to the machine for maintenance.

WARNING

Before removing any guards, shut the engine off and remove the ignition key. Wait for all moving parts to come to a complete stop before beginning work.

To remove the operator cushion and rear cover:

1. Loosen the two (2) wing nuts securing the operator cushion to the machine. See Figure 6-12.
2. Lift upward to remove the operator cushion. See Figure 6-12.
3. Remove the two (2) wing nuts securing the rear cover to the back of the machine and remove the cover. See Figure 6-12.

WARNING

Do not operate the machine without the operator cushion or rear cover installed.

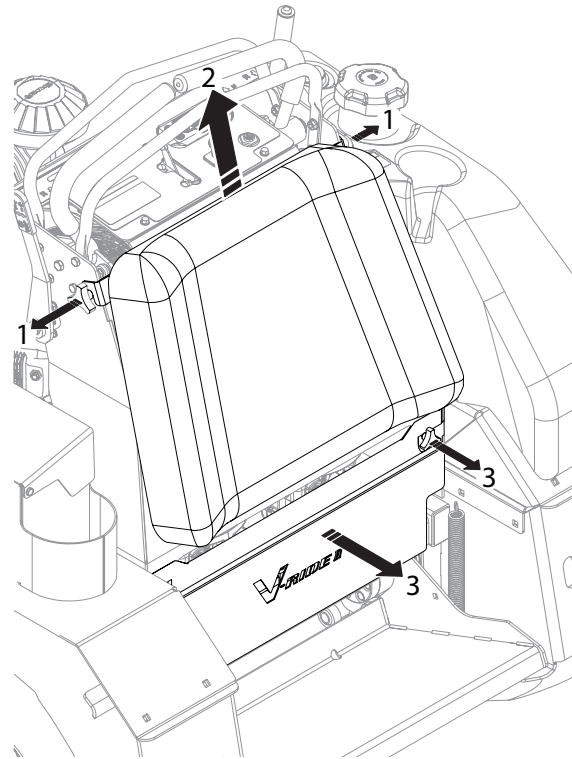

Figure 6-12. Operator Cushion and Rear Cover Removal

MAINTENANCE

7.1 MAINTENANCE CHART - RECOMMENDED SERVICE INTERVALS

BREAK-IN (FIRST 10)	HOURS						PROCEDURE	COMMENTS
	8	20	40	100	200	500		
X							Check all hardware for tightness	
X							Check hydraulic oil level	See paragraph 7.3
X							Check belts for proper alignment	See paragraph 6.5
	X						Check hydraulic hoses for leaks	Use extreme caution when checking the hydraulic hoses. See paragraph 2.5
	X						Check engine oil level	See paragraph 7.4
	X						*Clean mower	
	X						Check tire pressure	See paragraph 7.9
	X						*Clean air filter element	See paragraph 7.6
	X						Check condition of blades	See paragraph 7.8
	X						Apply grease to fittings	See paragraph 7.2
	X						Check safety interlock system	See paragraph 4.2
		X					Change engine oil and filter	See paragraph 7.4
			X				Check belts for proper alignment	See paragraph 6.5
			X				Inspect pump drive belt. Replace every 400 hours or 2 years, whichever comes first.	See paragraph 6.4 & 7.8
				X			Check belts for proper alignment	See paragraph 6.5
				X			Check condition of fuel lines	
				X			*Clean engine air filter	See engine operator's manual
				X			Apply grease to fittings	See paragraph 7.2
				X			Check all hardware for tightness	
				X			Change engine oil	See paragraph 7.4
				X			*Clean air cleaner element	See paragraph 7.6

* Perform these maintenance procedures more frequently under extreme dusty or dirty conditions

MAINTENANCE CHART - RECOMMENDED SERVICE INTERVALS (CONT'D)

BREAK-IN (FIRST 10)	HOURS					PROCEDURE	COMMENTS
	8	40	100	200	500		
				X		Check hardware for tightness	
				X		Apply grease to fittings	See paragraph 7.2
				X		Check hydraulic oil level	See paragraph 7.3
				X		Change engine oil	See paragraph 7.4
				X		Change engine oil filter	See paragraph 7.4
					X	Replace engine fuel filter	See paragraph 7.5
					X	Apply grease to fittings	See paragraph 7.2
					X	Drain hydraulic system and replace oil and filter	See paragraph 7.3
					X	Adjust electric PTO clutch	See paragraph 6.6

7.2 LUBRICATION

GREASE FITTING LUBRICATION CHART

LOCATION	LUBRICATION INTERVAL	LUBRICANT	NO. OF PLACES
1 - Caster Wheel Pivot	500 Hours / Yearly	Chassis Grease	2
2 - Caster Wheel Bearings	100 Hours / Monthly	Chassis Grease	2
3 - Cutter Deck Bell Cranks	100 Hours / Bi-Weekly	Chassis Grease	4
4 - Cutter Deck Spindles	40 Hours / Weekly	+ US Lithium MP White Grease	2 / 3
5 - Cutter Deck Pusharms	100 Hours / Bi-Weekly	Chassis Grease	2

+ Compatible Greases: Mobilgrease XHP 222
Exxon Mobil Ronex MP
Exxon Mobil Unirex EP2

Section 7

GREASE FITTING LUBRICATION Lubricant Interval

□ Lithium MP White Grease 2125
(40 Hours/Weekly)

○ Chassis Grease
(100 Hours/Bi-weekly)

△ Chassis Grease
(500 Hours/Yearly)

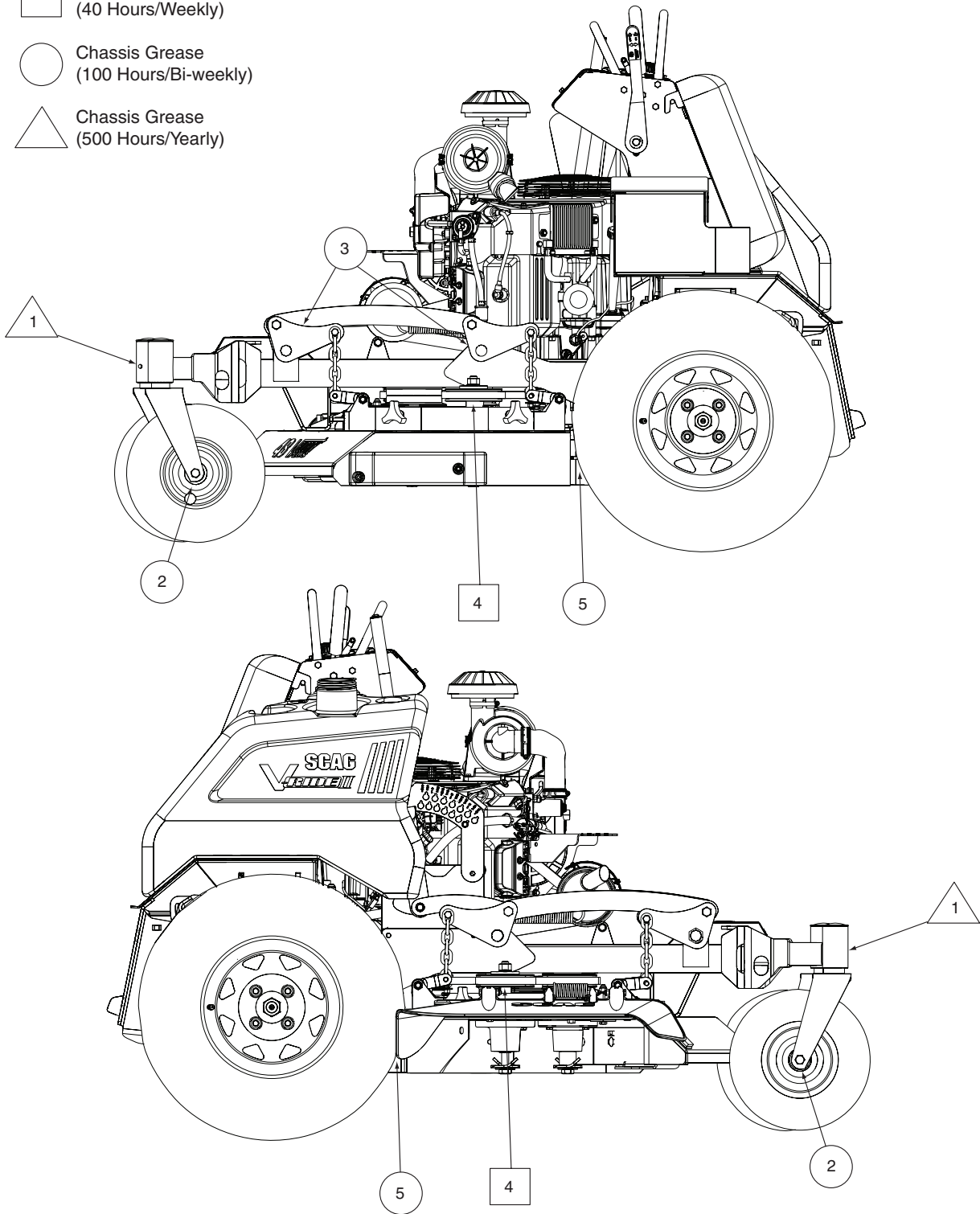

Figure 7-1. Lubrication Fitting Points

7.3 HYDRAULIC SYSTEM

A. CHECKING HYDRAULIC OIL LEVEL

The hydraulic oil level should be checked after the first 8 hours of operation. Thereafter, check the oil after every 200 hours of machine operation or monthly, whichever occurs first.

- IMPORTANT -

If the oil level is consistently low, check for leaks and correct immediately.

1. Remove the operator cushion as outlined in Section 6.9.
2. Wipe dirt and contaminants from around the reservoir cap. Remove the cap from the hydraulic oil reservoir.
3. Visually check the level of hydraulic oil. Hydraulic oil must be at least 2-1/4" inches from top of the filler neck. If the level cannot be determined visually, use a clean tape measure to check the level. If the fluid is low, add 20W50 motor oil. DO NOT overfill; (overfilling the oil reservoir may cause oil seepage around the cap area).
4. Clean the fill cap and install it onto the reservoir.

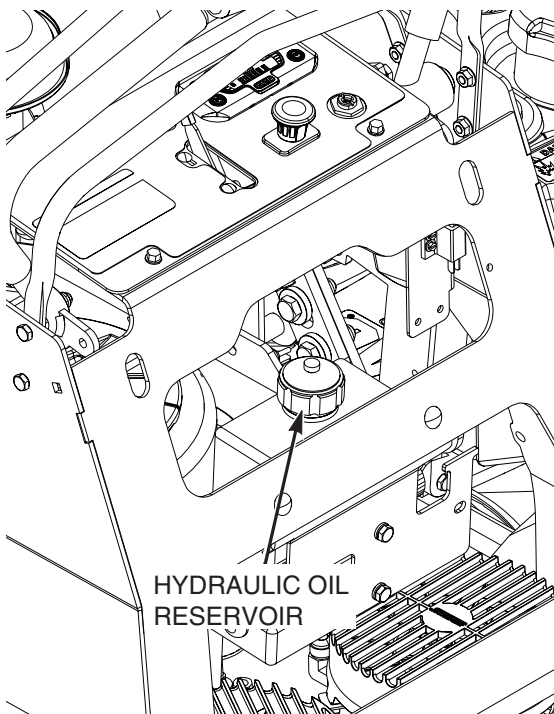

Figure 7-2. Hydraulic Oil Reservoir

B. CHANGING HYDRAULIC OIL

The hydraulic oil should be changed after every 500 hours or annually, whichever occurs first. The oil should also be changed if the color of the fluid has become black or milky. A black color and/or a rancid odor usually indicates possible overheating of the oil, and a milky color usually indicates water in the hydraulic oil.

- IMPORTANT -

The hydraulic oil should be changed if you notice the presence of water or a rancid odor to the hydraulic oil.

1. Park the mower on a level surface, stop the engine and remove the ignition key.
2. Remove the operator cushion and rear cover as outlined in Section 6.9.
3. Place a suitable container under the hydraulic oil filter. Remove the fill cap from the reservoir. Remove the drain plug from the remote oil drain hose. See Figure 7-3. Allow the fluid to drain into the container and properly discard it.
4. Re-install the drain plug into the remote draining hose and be sure it is tight.

- NOTE -

Before refilling the hydraulic oil reservoir the hydraulic oil filter should be changed as outlined in Procedure C "Changing Hydraulic Oil Filter Element".

5. Fill the reservoir to full 2-1/4" inches below the filler neck with 20W50 motor oil.
6. Replace the reservoir fill cap. Start the engine and drive forward and backward for two minutes. Check the oil level in the reservoir. If necessary, add oil to the reservoir.

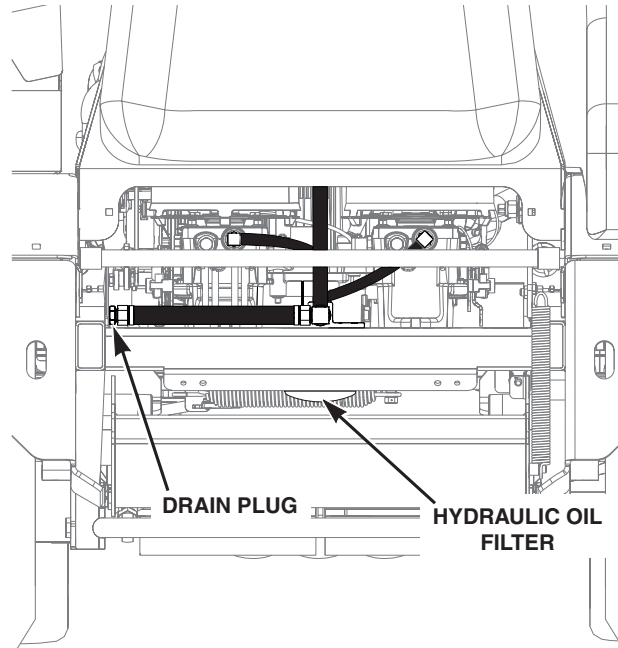

Figure 7-3. Hydraulic Oil Filter

C. CHANGING HYDRAULIC OIL FILTER ELEMENT

The hydraulic oil filter should be changed after every 500 hours of operation or annually, whichever occurs first.

1. Remove the oil filter element. See Figure 7-3. Properly discard the oil filter element. Fill the new filter with clean oil and install the filter. Hand tighten only.
2. Run the engine at idle speed with the speed control lever in neutral for five minutes.
3. Check the oil level in the hydraulic tank. Hydraulic oil must be at least 2-1/4" inches from top of the filler neck. If the level cannot be determined visually, use a clean tape measure to check the level. If the fluid is low, add 20W50 motor oil.

7.4 ENGINE OIL

A. CHECKING ENGINE CRANKCASE OIL LEVEL

The engine oil level should be checked after every 8 hours of operation or daily as instructed in the Engine Operator's Manual furnished with this mower.

B. CHANGING ENGINE CRANKCASE OIL

After the first 20 hours of operation, change the engine crankcase oil and replace the oil filter. Thereafter, change the engine crankcase oil after every 100 hours of operation or monthly, whichever occurs first. Refer to the Engine Operator's Manual furnished with this mower for instructions.

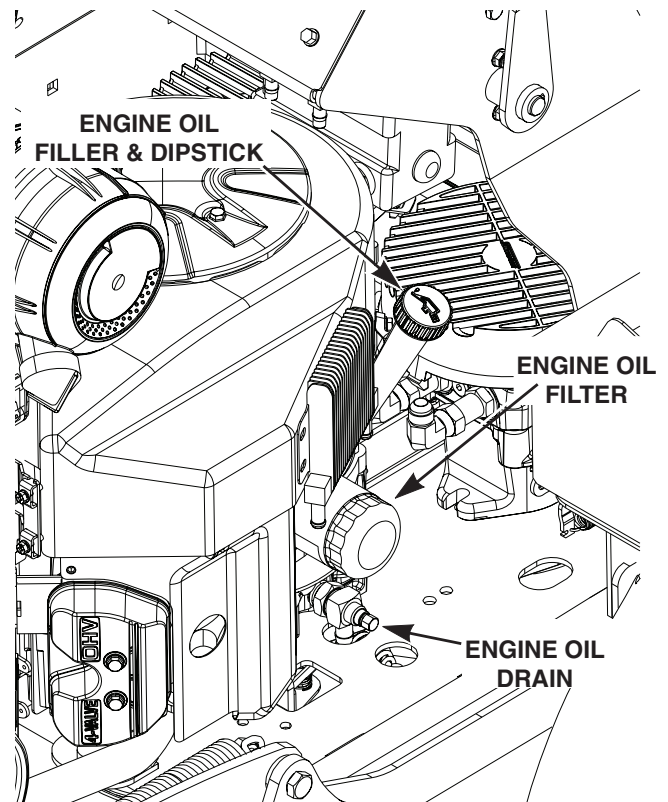

Figure 7-4. Drain Plug, Dipstick and Oil Filter Location

C. CHANGING ENGINE OIL FILTER

After the first 20 hours of operation, replace the engine oil filter. Thereafter, replace the oil filter after every 200 hours of operation or every month, whichever occurs first. Refer to Engine Operator's Manual for instructions.

DANGER

To avoid injury from burns, allow the mower to cool before changing the oil and removing the filter.

7.5 ENGINE FUEL SYSTEM

DANGER

To avoid injury from burns, allow the mower to cool before removing the fuel tank cap and refueling.

A. FILLING THE FUEL TANK

Fill the fuel tank to the bottom of the filler neck insert (approximately 7 gallons for 36" models or 8 gallons for all other models indicating Full (F) on the fuel gauge) at the beginning of each operating day. See Figure 7-5. Do not overfill. Use clean, fresh unleaded gasoline with a minimum octane rating of 87 and a maximum of 10% Ethanol.

DO NOT use E85 Fuel. Using E85 Fuel will cause severe damage to the engine.

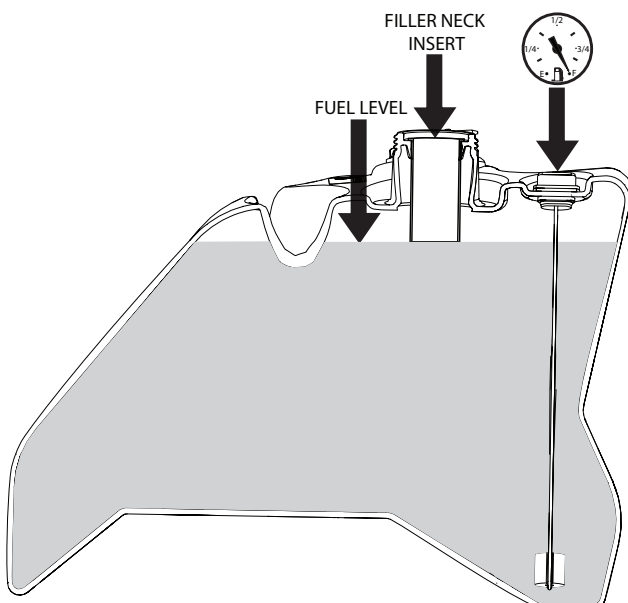

Figure 7-5. C.A.R.B. / EPA Phase 3 Fuel Level

To avoid personal injury or property damage, use extreme care in handling gasoline. Gasoline is extremely flammable and the vapors are explosive.

1. Extinguish all cigarettes, cigars, pipes and other sources of ignition.
2. Use only an approved gasoline container.
3. Never remove the gas cap or add fuel with the engine running. Allow the engine to completely cool before fueling.
4. Never fuel the machine indoors or in an enclosed trailer.
5. Never store the machine or fuel container where there is an open flame, spark or pilot light such as on a water heater or other appliances.
6. Never fill containers inside a vehicle or on a truck or trailer bed with a plastic liner. Always place containers on the ground away from your vehicle before filling.
7. Remove the machine from the truck or trailer and fuel on the ground. If this is not possible, then refuel the machine with a portable container, rather than from a gasoline dispenser nozzle.
8. Keep the nozzle in contact with the rim of fuel tank or container opening at all times until fueling is complete. Do not use a nozzle lock-open device.
9. If fuel is spilled on clothing, change clothing immediately and wash affected skin.
10. Replace gas cap and tighten the fuel cap until it ratchets.

B. REPLACING IN-LINE FUEL FILTER ELEMENTS

The engine fuel filter should be replaced after every 500 hours of operation or annually, whichever occurs first. See Figure 7-6.

1. Close the shutoff valve. Locate the fuel filter and remove the two clamps securing the fuel filter to the fuel hose. Remove the fuel filter.
2. Install a new fuel filter. Be sure it is installed in the proper direction. Secure to the fuel hose using the two clamps.

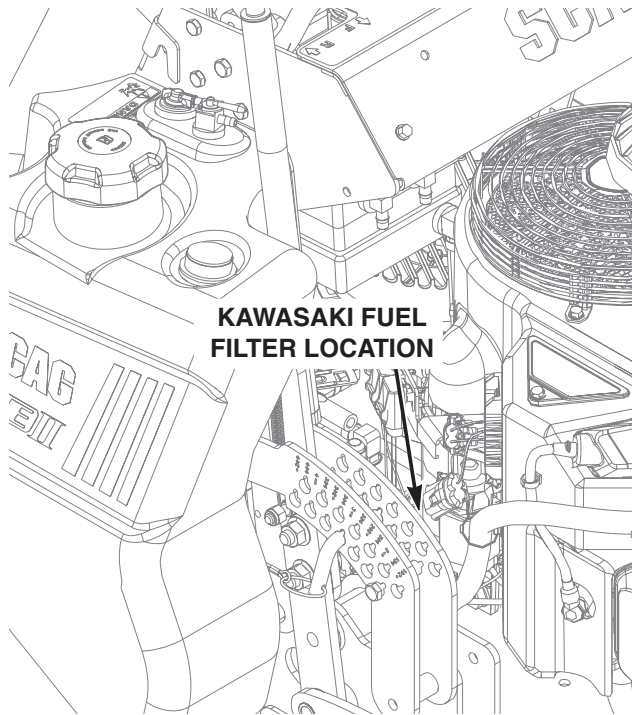

Figure 7-6. Kawasaki Fuel Filter Location

7.6 ENGINE AIR CLEANER

A. CLEANING AND/OR REPLACING AIR CLEANER ELEMENT

For any air cleaner, the operating environment dictates the air cleaner service periods. Inspect and clean the air cleaner element after every 100 hours of operation or monthly, whichever occurs first and replace the element if required. See Engine Owner's Manual for service information.

- NOTE -

In extremely dusty conditions it may be necessary to check the element once or twice daily to prevent engine damage.

1. Snap open the two clips securing the air cleaner cover to the air cleaner box. Remove the air cleaner cover, clean the duck bill vent of any dust or debris and set the cover aside.
2. Remove the air cleaner and inspect.
3. Clean or replace the air cleaner as recommended by the engine manufacturer. Replace the air cleaner cover and secure.
4. Replace the air filter cover and be sure to snap the two clips closed.

7.7 BATTERY - ELECTRIC START MODELS

WARNING

Lead-acid batteries produce flammable and explosive gases. To avoid personal injury when checking, testing or charging batteries, **DO NOT** use smoking materials near batteries. Keep arcs, sparks and flames away from batteries. Provide proper ventilation and wear safety glasses.

WARNING

Battery posts, terminals, and related accessories contain lead and lead compounds, chemicals known to cause cancer and reproductive harm. Wash hands after handling.

WARNING

Electric storage battery fluid contains sulfuric acid which is **POISON** and can cause **SEVERE CHEMICAL BURNS**. Avoid contact of fluid with eyes, skin, or clothing. Use proper protective gear when handling batteries. **DO NOT** tip any battery beyond 45° angle in any direction. If fluid contact does occur, follow first aid suggestions below.

BATTERY ELECTROLYTE FIRST AID

External Contact — Flush with water.

Eyes — Flush with water for at least 15 minutes and get medical attention immediately.

Internal — Drink large quantities of water. Follow with Milk Of Magnesia, beaten egg, or vegetable oil. Get medical attention immediately. In case of internal contact, **DO NOT give fluids that would induce vomiting.**

A. CHARGING THE BATTERY

Refer to the battery charger's manual for specific instructions.

Under normal conditions the engine's alternator will have no problem keeping a charge on the battery. If the battery has been completely discharged for a long period of time, the alternator may not be able to recharge the battery, and a battery charger will be required.

DO NOT charge a frozen battery. It may explode and cause injury. Let the battery warm before attaching a charger.

Whenever possible, remove the battery from the mower before charging.

 WARNING
BATTERIES PRODUCE EXPLOSIVE GASES. Charge the battery in a well ventilated space so gases produced while charging can dissipate.

Charging rates between 3 and 50 amperes are satisfactory if excessive gassing or spewing of electrolyte does not occur or the battery does not feel excessively hot (over 125°F). If spewing or gassing occurs or the temperature exceeds 125°F, the charging rate must be reduced or temporarily stopped to permit cooling.

B. JUMP STARTING

1. The booster battery must be a 12 volt type. If a vehicle is used for jump starting, it must have a negative ground system.
2. When connecting the jumper cables, connect the positive cable to the positive battery post, then connect the negative cable to the negative battery post.

7.8 DRIVE BELTS

All drive belts are spring-loaded and self-tensioning, however after the first 2, 4, 8 and 10 hours of operation, the belts should be checked for proper alignment and wear. Thereafter, check the belts after every 40 hours of operation or weekly, whichever occurs first.

If you experience frequent belt wear or breakage, see your authorized Scag service center for belt adjustment.

 WARNING
If the pump drive belt fails, steering control will be lost which could result in serious injury or death. Replace the pump drive belt as needed or every 400 hours / 2 years, whichever occurs first.

7.9 CUTTER BLADES

A. BLADE INSPECTION

1. Remove the ignition key before servicing the blades.
2. Raise the mower deck to the highest position. Place the lanyard pin in the highest cutting height position to prevent the cutter deck from falling.

 WARNING
Always wear proper hand and eye protection when working with cutter blades.

3. Check the cutter blades for straightness. If the cutter blades appear bent, they will need to be replaced.
4. Check the cutter blades for wear. If any part of the cutter blade is worn to 1/2 its original thickness, replace the cutter blade.

 WARNING
Do not attempt to straighten a bent blade, and never weld a broken or cracked blade. Always replace it with a new blade to assure safety.

5. If a blade cutting edge is dull or nicked, it should be sharpened. Remove the blades for sharpening. See "Blade Replacement."

- NOTE -

Section 7

- NOTE -

Keep the blades sharp. Cutting with dull blades not only yields a poor mowing job, but slows the cutting speed of the mower and causes extra wear on the engine and the blade drive by pulling hard.

B. BLADE SHARPENING

- NOTE -

If possible, use a file to sharpen the blade. Using a wheel grinder may burn the blade.

- NOTE -

DO NOT sharpen the blades beyond 1/3 of the width of the blade. See Figure 7-7.

1. Sharpen the cutting edge at the same bevel as the original. See Figure 7-7. Sharpen only the top of the cutting edge to maintain sharpness.

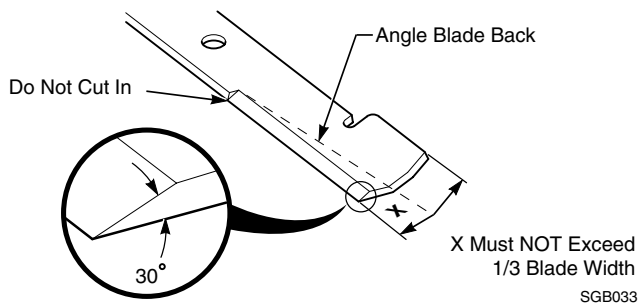

Figure 7-7. Blade Sharpening

2. Check the balance of the blade. If the blades are out of balance, vibration and premature wear can occur. The cutter blades should be balanced to 1-1/2 oz-in. See your authorized Scag dealer for blade balancing or special tools, if you choose to balance your own blades.

C. BLADE REPLACEMENT

WARNING

Always wear proper hand and eye protection when working with cutter blades.

1. Remove the ignition key before replacing the blades.
2. Raise the mower deck to the highest position. Place the lanyard pin in the highest cutting height position to prevent the cutter deck from falling.
3. Secure the cutter blades to prevent them from rotating, (use the optional Blade Buddy tool, P/N 9212, to assist in securing the cutter blades), remove the nut from the blade attaching bolt. Remove the cutter blade, bolt and spacer from the spindle shaft. See Figure 7-8.

- NOTE -

The front of the machine will have to be raised slightly to remove the blade bolt from the cutter spindle.

CAUTION

Inspect the cutter blade spacer(s) and washer for wear and/or cupping. Replace the worn parts. Worn spacer(s) and/or washer will not allow proper tightening of the cutter blade and can lead to cutter blade failure, personal injury or property damage.

4. To install the new cutter blade, put the flat washer onto the blade bolt and slide the bolt into the hole in the cutter blade.
5. Install the spacer onto the blade bolt and insert the bolt into the cutter spindle shaft.
6. Install the hex nut to the blade bolt at the top of the cutter spindle. Secure the blades from rotating and torque to 75 ft/lbs. See Figure 7-8.

- NOTE -

Be sure that the blade is installed with the lift wing pointing toward the top of the deck.

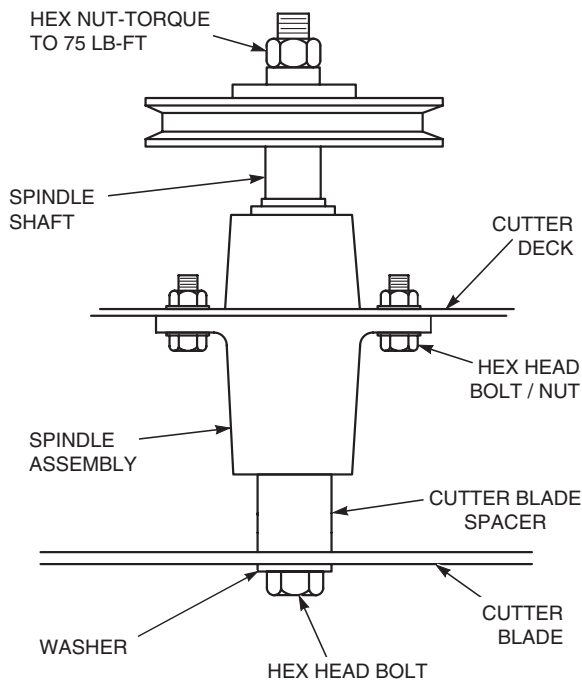

Figure 7-8. Blade Replacement

7.10 TIRES

Check the tire pressures after every 8 hours of operation or daily.

Caster Wheels	Flat-Free
Drive Wheels	12 PSI

7.11 BODY AND DECK

CAUTION

Do not wash any portion of the equipment while it is hot. Do not wash the engine; use compressed air.

1. After each use, wash the mower and cutter deck. Use cold water and automotive cleaners. Do not use pressure cleaners.
2. Do not spray electrical components.
3. Repair damaged metal surfaces using Scag touch-up paint (P/N 48521 -Aerosol Can & 484540-01 - 0.6fl.oz. Bottle with brush) available from your authorized Scag dealer. Wax the mower with an automotive paint wax for maximum paint protection.

ILLUSTRATED PARTS LIST

8.1 SCAG APPROVED ATTACHMENTS AND ACCESSORIES.

Attachments and accessories manufactured by companies other than Scag Power Equipment are not approved for use on this machine.

Scag approved attachments and accessories:

- Mulch Plate (p/n 9258, 9286, 9287, 9288)
- Hurricane Mulch (p/n 9263, 9283, 9284, 9285)
- GC-F4 (p/n 9075)
- SVR11-OCDC (p/n 923N, 923P, 923Q)
- SVR11 Lights (p/n 923R)
- Air Filter Indicator (p/n 922U)
- Blade Buddy (p/n 9212)
- Chrome Wheel Covers (p/n 920J) - 48 / 52 / 61 Only

36A CUTTER DECK

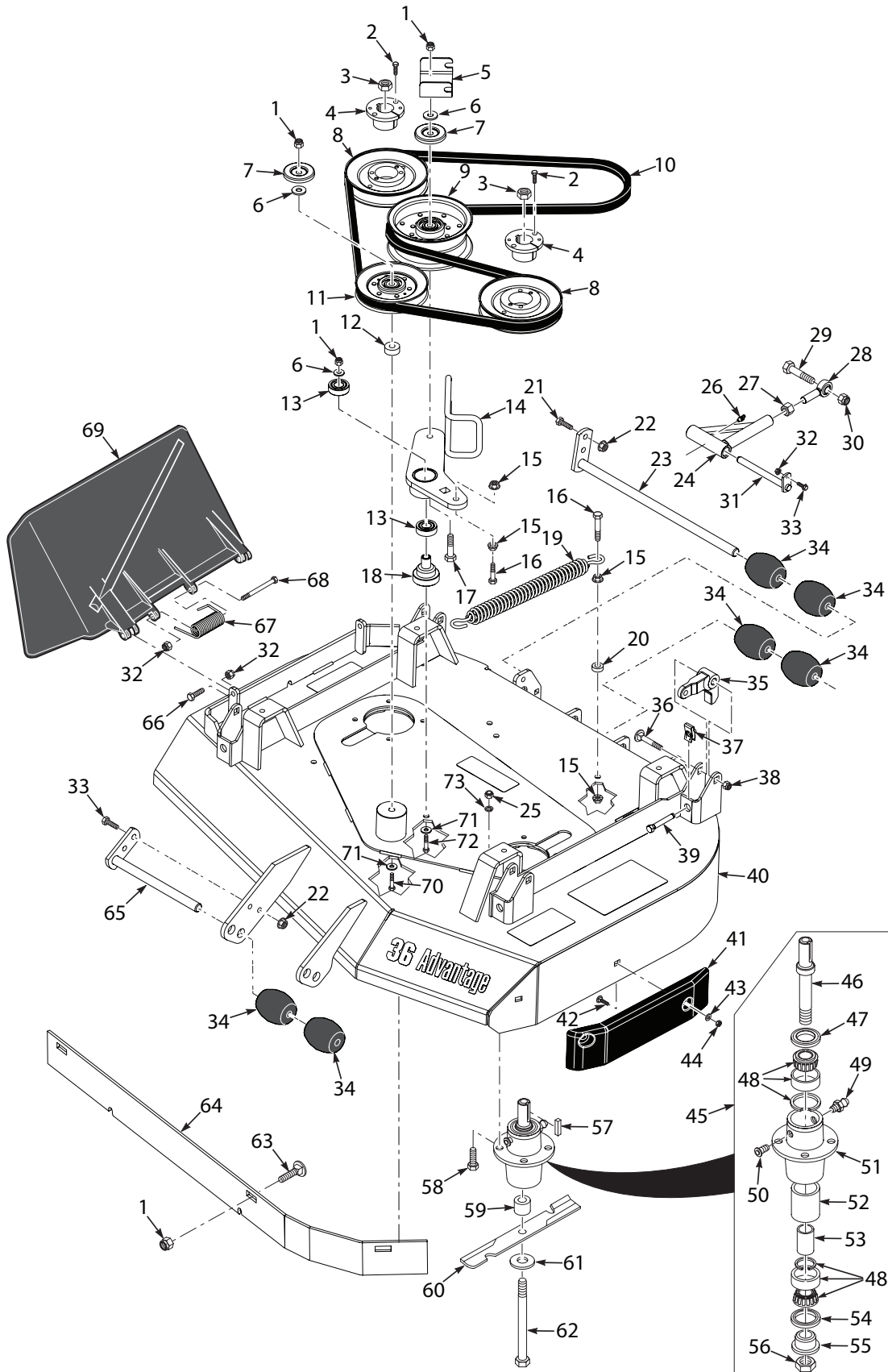

36A CUTTER DECK

Ref. No.	Part No.	Description
1	04021-09	Nut, Elastic Stop 3/8-16
2	04001-172	Bolt, Hex Head 1/4-20 x 1" Gr.8
3	04020-09	Nut, 5/8-11
4	48926	Tapered Locking Hub
5	424615	Bracket, Belt Guide
6	04043-04	Flatwasher, 3/8-.391 x .938 x .105 HD
7	424367	Dustshield
8	483284	Pulley, 5.73" Dia.
9	483210	Pulley, 5" Idler
10	486023	Belt, Cutter Deck
11	48181	Pulley, Idler
12	43077	Spacer
13	48224	Bearing
14	462984	Idler Arm Assembly (Incl. #13)
15	04019-04	Nut, Serrated Flange 3/8-16
16	04001-136	Bolt, Hex Head 3/8-16 x 1-1/2" Gr. 8
17	04001-62	Bolt, Hex Head 3/8-16 x 3-1/4"
18	43816	Pivot, Idler
19	484020	Spring
20	43063	Spacer
21	04003-04	Bolt, Carriage 5/16-18 x 1"
22	04117-01	Nut, Flange Elastic Stop 5/16-18
23	452236	Shaft Weldment
24	462323	Pusharm Assembly, LH
	462324	Pusharm Assembly, RH
25	04021-22	Nut, Elastic Stop 5/16-18 Gr. 8
26	48114-08	Grease Fitting, 90 Degree
27	04020-16	Nut, 5/16-18 UNF
28	48763	Rod End, 5/8 - Male RH
29	04001-79	Bolt, Hex Head 5/8-11 x 4-1/2"
30	04021-13	Nut, Elastic Stop 5/8-11
31	451724	Shaft Weldment, Pusharm Mounting
32	04021-10	Nut, Elastic Stop 5/16-18
33	04001-09	Bolt, Hex Head 5/16-18 x 1"
34	482295	Wheel, Anti-Scalp
35	485528	Lever, Deck Level
36	04003-42	Bolt, Carriage 7/16-14 x 2-1/4"
37	04110-03	U-Nut, 3/8-16
38	04021-11	Nut, Elastic Stop 7/16-14
39	04107-04	Bolt, Hex Head 3/8-16 x 2" Special Lock
40	462986	Cutter Deck w/Decals
41	483174	Pad, Wear
42	04003-12	Bolt, Carriage 5/16-18 x 3/4"
43	04040-04	Flatwasher, 5/16-.344 x .688 x .065
44	04021-04	Nut, Center Lock 5/16-18

Ref. No.	Part No.	Description
45	461663	Spindle Assembly
46	43589	Spindle Shaft
47	481024	Seal, Cutter Spindle
48	481022	Bearing, Tapered
49	48114-04	Grease Fitting
50	48677	Relief Fitting, Cutter Spindle
51	43644	Spindle Housing
52	43312	Spacer, Outside
53	43296	Spacer, Inside
54	481025	Seal, Cutter Spindle
55	43297	Spindle Bushing
56	481035	Nut, 1.06 - 18
57	04063-08	Key, 1/4 x 1/4 x 2"
58	04001-175	Bolt, Hex Head 5/16-18 x 1-1/2" Gr. 8
59	43590	Spacer, Spindle Bottom
60	482878	Cutter Blade, 18"
61	04043-06	Flatwasher, 5/8-.688 x 1.75 x .134 HD
62	04001-41	Bolt, Hex Head 5/8-11 x 9-1/2"
63	04003-23	Bolt, Carriage 3/8-16 x 1"
64	423783	Baffle, Flange - 36A
65	451926	Shaft Weldment
66	04001-12	Bolt, Hex Head 5/16-18 x 1-3/4"
67	482245	Spring, Discharge Chute
68	04001-154	Bolt, Hex Head 5/16-18 x 4-3/4"
69	461295	Discharge Chute Assy.
	462469	Discharge Chute Assy. (CA)
70	04001-198	Bolt, Hex Head 3/8-16 x 4-3/4"
71	04041-11	Flatwasher, 3/8-.406 x 1.50 x .179
72	04001-62	Bolt, Hex Head 3/8-16 x 3-1/4"
73	04030-03	Lockwasher, 5/16"

48V, 52V & 61V CUTTER DECKS

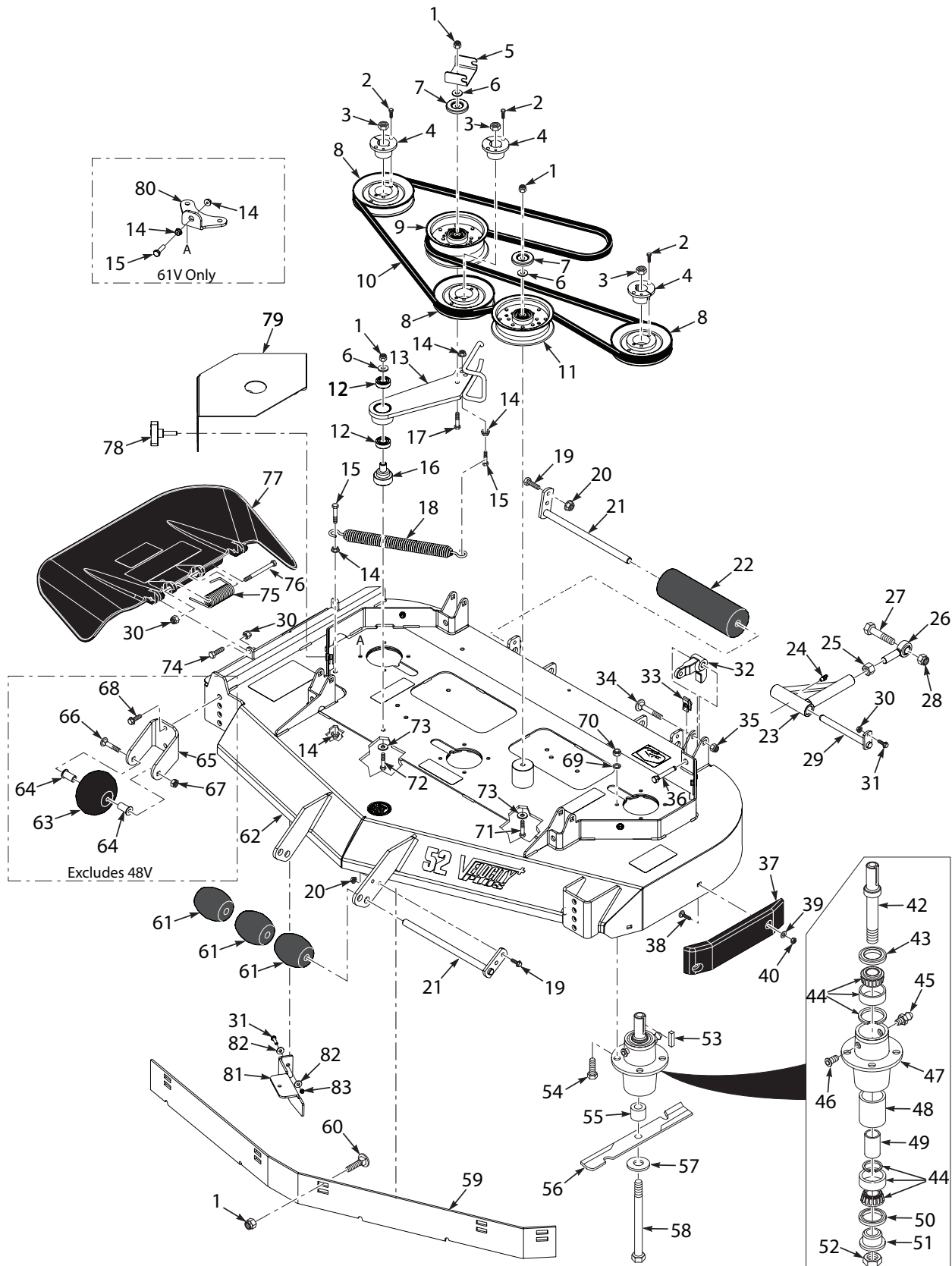

Section 8

48V, 52V & 61V CUTTER DECKS

Ref. No.	Part No.	Description
1	04021-09	Nut, Elastic Stop 3/8-16
2	04001-172	Bolt, Hex Head 1/4-20 x 1" Gr.8
3	04020-09	Nut, 5/8-11
4	48926	Tapered Hub
5	424615	Bracket, Belt Guide
6	04043-04	Flatwasher, 3/8-.391 x .938 x .105 HD
7	424367	Dust Shield
8	483282	Pulley, 5.13" Dia. - 48V
	483284	Pulley, 5.73" Dia. - 52V
	483286	Pulley, 6.32" Dia - 61V
9	483210	Pulley, 5" Idler
10	483966	Belt, Cutter Deck - 48V
	484100	Belt, Cutter Deck - 52V
	485880	Belt, Cutter Deck - 61V
11	483215	Pulley, 5" Idler
12	48224	Bearing
13	462973	Idler Arm Assy. - 48V (Incl. #12)
	462975	Idler Arm Assy. - 52V (Incl. #12)
	462333	Idler Arm Assy. - 61V (Incl. #12)
14	04019-04	Nut, Serrated Flange 3/8-16
15	04001-136	Bolt, Hex Head 3/8-16 x 1-1/2" Gr.8
16	43681	Pivot, Idler
17	04001-62	Bolt, Hex Head 3/8-16 x 3-1/4"
18	484020	Spring
19	04001-09	Bolt, Hex Head 5/16-18 x1"
20	04117-01	Nut, Flange Elastic Stop 5/16-18
21	45944	Shaft Weldment
22	48038	Guide Roller
23	462323	Pusharm Assy, LH
	462324	Pusharm Assy, RH
24	48114-08	Grease Fitting, 90 Degree
25	04020-16	Nut, 5/8-18 UNF
26	48763	Rod End, 5/8 Male RH
27	04001-79	Bolt, Hex Head 5/8-11 x 4-1/2"
28	04021-13	Nut, Elastic Stop 5/8-11
29	451724	Shaft Weldment, Pusharm Mounting
30	04021-10	Nut, Elastic Stop 5/16-18
31	04001-09	Bolt, Hex Head 5/16-18 x 1"
32	485528	Lever, Deck Level
33	04110-03	U-Nut, 3/8-16
34	04003-42	Bolt, Carriage 7/16-14 x 2-1/4"
35	04021-11	Nut, Elastic Stop 7/16-14
36	04107-04	Bolt, Hex Head 3/8-16 x 2" Special Lock
37	483176	Pad, Wear
38	04003-12	Bolt, Carriage 5/16-18 x 3/4"
39	04040-04	Flatwasher, 5/16-.344 x .688 x .065
40	04021-04	Nut, Center Lock 5/16-18
41	461663	Spindle Assembly
42	43589	Spindle Shaft
43	481024	Seal, Cutter Spindle
44	481022	Bearing, Tapered

Ref. No.	Part No.	Description
45	48114-04	Grease Fitting
46	48677	Relief Fitting, Cutter Spindle
47	43644	Spindle Housing
48	43312	Spacer, Outside
49	43296	Spacer, Inside
50	481025	Seal, Cutter Spindle
51	43297	Spindle Bushing
52	481035	Nut, 1.06 - 18
53	04063-08	Key, 1/4 x 1/4 x 2"
54	04001-175	Bolt, Hex Head 5/16-18 x 1-1/2" Gr.8
55	43590	Spacer, Spindle Bottom
56	482877	Cutter Blade, 16-1/2" (48V)
	482878	Cutter Blade, 18" (52V)
	482881	Cutter Blade, 21" (61V)
57	04043-06	Flatwasher, 5/8-.688 x 1.75 x .134 HD
58	04001-41	Bolt, Hex Head 5/8-11 x 9-1/2"
59	424839	Baffle, Flange - 48V
	424840	Baffle, Flange - 52V
	424841	Baffle, Flange - 61V
60	04003-23	Bolt, Carriage 3/8-16 x 1"
61	482295	Wheel, Anti-Scalp
62	462972	Cutter Deck w/Decals - 48V
	462974	Cutter Deck w/Decals - 52V
	462976	Cutter Deck w/Decals - 61V
63	481632	Wheel, Anti-Scalp (Incl. #64)
64	48100-15	Bushing, Bronze
65	422478	Bracket, Anti-Scalp Wheel
66	04003-26	Bolt, Carriage 3/8-16 x 4"
67	04021-05	Nut, Center Lock 3/8-16
68	04017-27	Bolt, Hex Head Serrated Flange 3/8-16 x 1"
69	04030-03	Lockwasher, 5/16"
70	04021-22	Nut, Elastic Stop 5/16-18 Gr. 8
71	04001-47	Bolt, Hex Head 3/8-16 x 5"
72	04001-62	Bolt, Hex Head 3/8-16 x 3-1/4"
73	04041-38	Flatwasher, 3/8-.406 x 2.25 x .1875
74	04001-12	Bolt, Hex Head 5/16-18 x 1-3/4"
75	482245	Spring, Discharge Chute
76	04001-154	Bolt, Hex Head 5/16-18 x 4-3/4"
77	461844	Discharge Chute Assy. - 48V
	461845	Discharge Chute Assy. - 52V
	461846	Discharge Chute Assy. - 61V
78	481625-01	Knob w/Stud
79	427310	Belt Cover, LH - 48V
	427306	Belt Cover, RH - 48V
	427264	Belt Cover - 52V
	427363	Belt Cover, RH - 61V
	427362	Belt Cover, LH - 61V
80	427399	Anchor Bracket - 61V
81	424677	Turbo Baffle - 48V / 52V
	424209	Turbo Baffle - 61V
82	04040-15	Flatwasher, 5/16-.375 x .875 x .083
83	04021-10	Nut, Elastic Stop 5/16-18

SVR11 CUTTER DECK CONTROLS

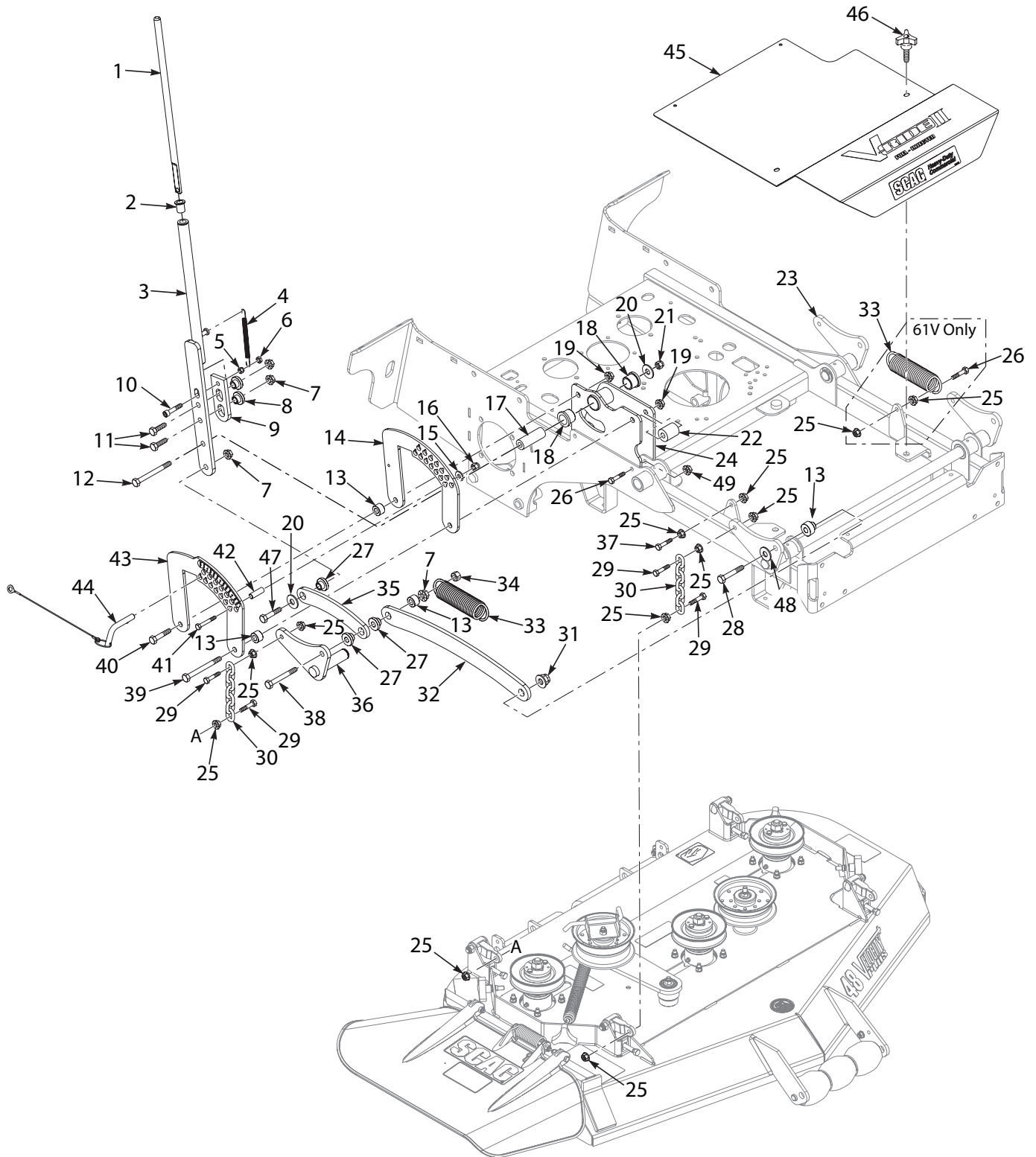

SVRII CUTTER DECK CONTROLS

Ref. No.	Part No.	Description
1	43747	Rod, Actuator
2	483463-14	Bearing
3	452811	Handle Weldment, Deck Latch
4	483600	Spring, Deck Latch
5	04021-09	Nut, Elastic Stop 3/8-16
6	04021-05	Nut, Center Lock 3/8-16
7	04019-06	Nut, Serrated Flange 1/2-13
8	43748	Bushing, Deck Latch
9	424652	Deck Latch, Outer
10	04015-41	Capscrew, Socket Head 3/8-16 x 1-3/4"
11	04001-183	Bolt, Hex Head 1/2-13 x 1-3/4"
12	04001-194	Bolt, Hex Head 1/2-13 x 4-1/4"
13	431064	Bushing, Deck Latch
14	427219	Bracket, Deck Height
15	04041-07	Flatwasher, 3/8-.391 x .938 x .105
16	04021-09	Nut, Elastic Stop 3/8-16
17	43872	Sleeve, Pivot
18	483453-03	Bearing
19	04019-06	Nut, Serrated Flange 1/2-13
20	04040-13	Flatwasher, 1/2-.562 x .375 x .109
21	04021-07	Nut, Elastic Stop 1/2-13
22	43666	Spacer
23	452808	Arm Weldment, LH
24	462951	Deck Lift Pivot Assy. (Incl. #18)

Ref. No.	Part No.	Description
25	04019-04	Nut, Serrated Flange 3/8-16
26	04001-19	Bolt, Hex Head 3/8-16 x 1"
27	43748	Bushing, Deck Latch
28	04001-52	Bolt, Hex Head 1/2-13 x 2-1/2"
29	04001-20	Bolt, Hex Head 3/8-16 x 1-1/2"
30	485864	Chain
31	04117-04	Nut, Flange Elastic Stop 1/2-13
32	427221	Link, Deck Lift
33	483374	Spring, Deck Lift
34	04021-19	Nut, Center Lock 1/2-13
35	427220	Link, Deck Lift
36	452809	Arm Weldment, RH
37	04001-136	Bolt, Hex Head 3/8-16 x 1-1/2" Gr.8
38	04001-52	Bolt, Hex Head 1/2-13 x 2-1/2"
39	04001-87	Bolt, Hex Head 1/2-13 x 4"
40	04001-72	Bolt, Hex Head 1/2-13 x 2"
41	04001-46	Bolt, Hex Head 3/8-16 2-1/4"
42	43668	Spacer
43	427288	Bracket, Deck Height - Outer
44	485857	Pin Assy. w/Lanyard
45	462971	Belt Cover w/Decals
46	481625-01	Knob w/Stud
47	04001-183	Bolt, Hex Head 1/2-13 x 1-3/4"
48	04043-08	Washer, Flat, 1/2-.562 x 1.375 x .109 HD
49	04117-02	Nut, Flanged Elastic Stop, 3/8-16

SVRII SHEET METAL COMPONENTS

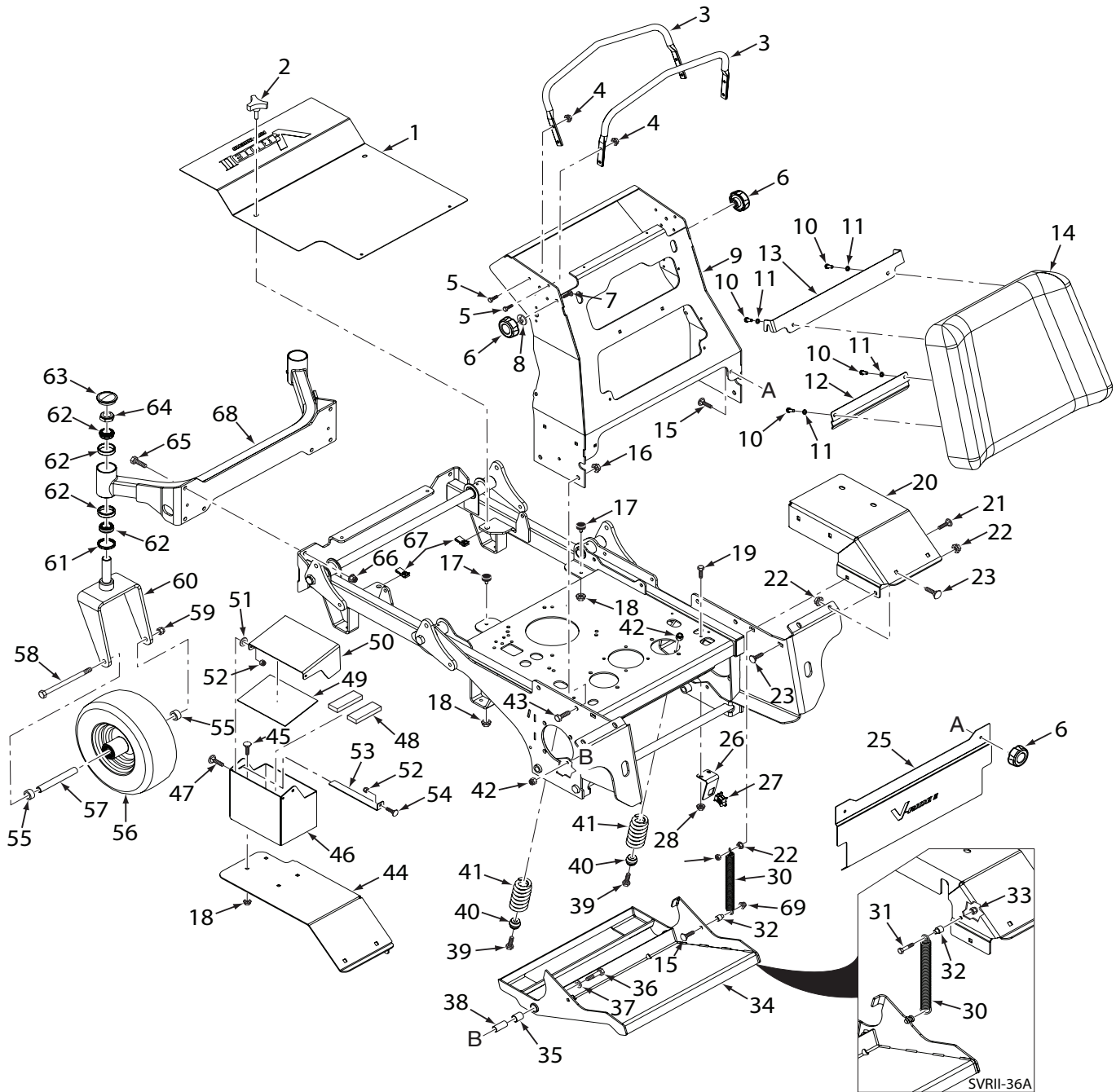

SVRII SHEET METAL COMPONENTS

Ref. No.	Part No.	Description
1	462971	Belt Cover w/Decals
2	481625-01	Knob w/Stud
3	427189	Reference Bar
4	04019-03	Nut, Serrated Flange 5/16-18
5	04001-08	Bolt, Hex Head 5/16-18 x 3/4"
6	481885-06	Knob, 5/16-18
7	04003-04	Bolt, Carriage 5/16-18 x 1"
8	04024-03	Nut, Push-On 5/16
9	452872	Handlebar Weldment, SVRII-36
	452832	Handlebar Weldment, SVRII
10	04001-08	Bolt, Hex Head 5/16-18 x 3/4"
11	04030-03	Lockwasher, 5/16"
12	427292	Bracket, Knee Pad - Lower
13	427289	Bracket, Knee Pad - Upper
14	462960	Operator Pad Assy, SVRII-36
	462950	Operator Pad Assy, SVRII
15	04003-12	Bolt, Carriage 5/16-18 x 3/4"
16	04112-05	Nut, Spiral Lock 1/2-13
17	481284	Rubber Bumper
18	04019-03	Nut, Serrated Flange 5/16-18
19	04001-01	Bolt, Hex Head 1/4-20 x 3/4"
20	427253	Fender, RH
	427457	Fender, LH - SVRII-36
21	04003-05	Bolt, Carriage 3/8-16 x 1-1/2"
22	04019-04	Nut, Serrated Flange 3/8-16
23	04003-31	Bolt, Carriage 3/8-16 x 3/4"
24	462987	Mainframe Assy. - SVRII-36
	462964	Mainframe Assy. - SVRII
25	427472	Guard, Foot - SVRII-36
	427256	Guard, Foot -SVRII
26	427481	Switch Bracket, OPC Switch -SVRII-36
	427249	Switch Bracket, OPC Switch
27	484497	Switch, Double Pole OPC - SVRII-36
	48717	Switch, OPC - SVRII
28	04019-02	Nut, Serrated Flange 1/4-20
29	04117-02	Nut, Flange Elastic Stop 3/8-16
30	48755	Spring
31	04001-11	Bolt, Hex Head 5/16-18 x 1-1/2"
32	43602	Spacer
33	04021-10	Nut, Elastic Stop 5/16-18
34	462959	Footplate Assy, SVRII-36 (Incl. #35)
	462949	Footplate Assy, SVRII (Incl. #35)
35	483453-04	Bearing
36	04001-45	Bolt, Hex Head 3/8-16 x 2"
37	04041-07	Flatwasher, 3/8-.391 x .938 x .105
38	43572	Spacer
39	04001-21	Bolt, Hex Head 3/8-16 x 1-3/4"
40	43867	Mount, Spring

Ref. No.	Part No.	Description
41	484479	Spring, Suspension Platform
42	04021-09	Nut, Elastic Stop 3/8-16
43	04017-36	Bolt, Hex Head Serrated Flange 1/2-13 x 1"
44	427456	Fender, LH - SVRII-36
	427252	Fender, LH
45	04003-12	Bolt, Carriage 5/16-18 x 3/4"
46	427316	Battery Box, Lower
47	04003-07	Bolt, Carriage 1/4-20 x 1/2"
48	48661	Pad, Rubber
49	485692	Insulation, Battery Cover
50	427317	Battery Box, Upper
51	04040-14	Flatwasher, 1/4-.312 x .750 x .065
52	04021-08	Nut, Elastic Stop 1/4-20
53	427318	Battery Box Latch
54	04003-07	Bolt, Carriage 1/4-20 x 1/2"
55	43584	Spacer, Caster Wheel
56	921D	Caster Wheel Assy., 11 x 4 (36)
	9277	Caster Wheel Assy., 13 x 5 (48 / 52)
	9278	Caster Wheel Assy., 13 X 6.5 (61)
57	43844	Sleeve, Caster Wheel (36)
	43581	Sleeve, Caster Wheel (48 / 52)
	43583	Sleeve, Caster Wheel (61)
58	04001-80	Bolt, Hex Head 1/2-13 x 6-1/2" (36)
	04001-134	Bolt, Hex Head 1/2-13 x 7-1/2" (48 / 52)
	04001-167	Bolt, Hex Head 1/2-13 x 9-1/2" (61)
59	04021-07	Nut, Elastic Stop 1/2-13
60	452034	Yoke Weldment (36)
	451471	Yoke Weldment (48 / 52)
	451658	Yoke Weldment (61)
61	481025	Seal, 2" x 1.625 Bore
62	48668	Bearing w/ Race
63	484195	Cap, Grease
64	04021-20	Nut, Elastic Stop 1" - 14 Jam
65	04001-28	Bolt, Hex Head 7/16-14 x 1-1/4"
66	04021-11	Nut, Elastic Stop 7/16-14
67	04110-04	U-Nut, 3/8-16
68	452870	Caster Support Weldment (36)
	452861	Caster Support Weldment (48)
	452805	Caster Support Weldment (52)
	452806	Caster Support Weldment (61)
69	04117-01	Nut, Flange Elastic Stop 5/16-18

SVR11 STEERING CONTROLS

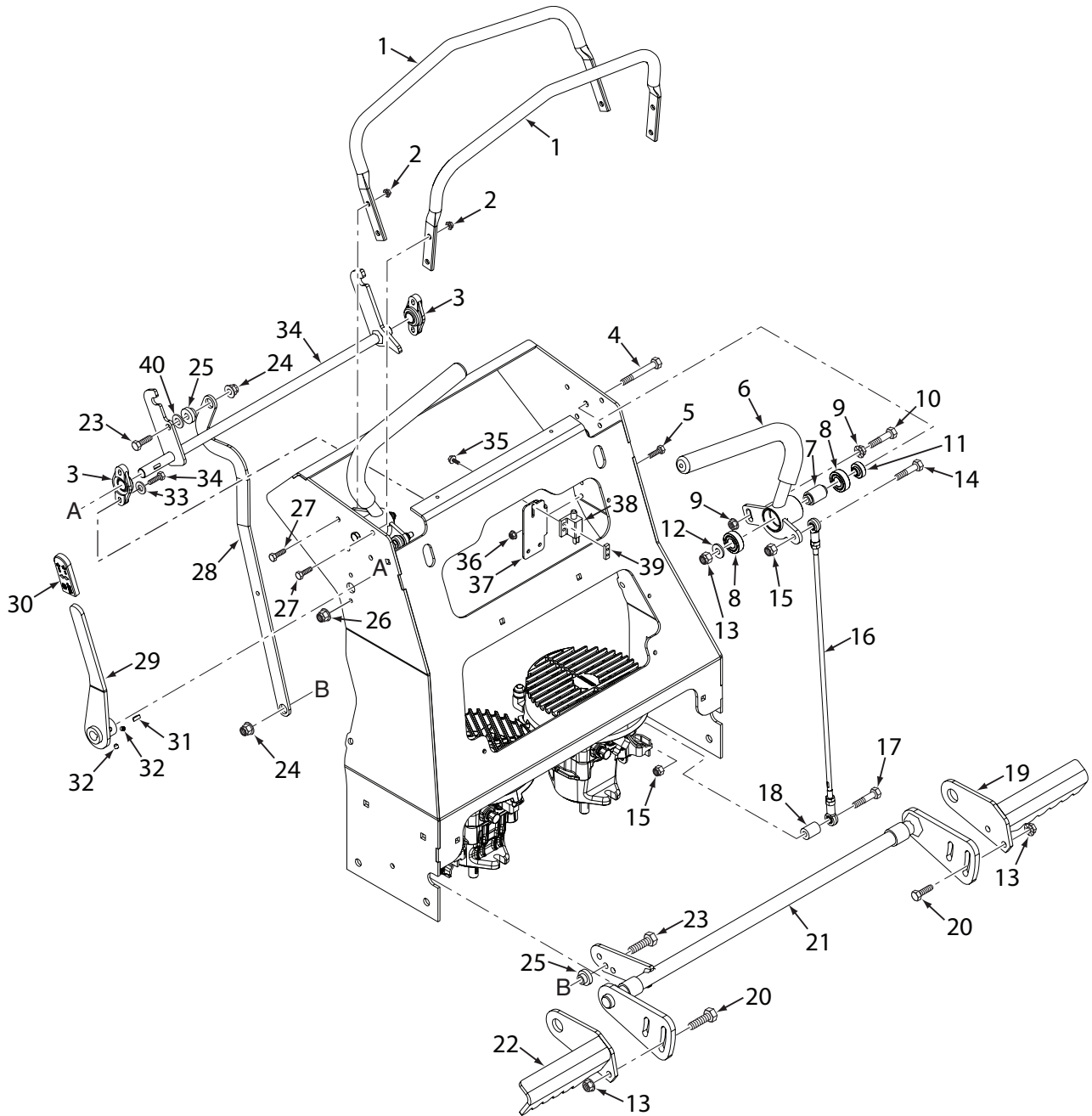

SVR11 STEERING CONTROLS

Ref. No.	Part No.	Description
1	427189	Reference Bar
2	04019-03	Nut, Serrated Flange 5/16-18
3	483504	Bearing
4	04001-62	Bolt, Hex Head 3/8-16 x 3-1/4"
5	04001-01	Bolt, Hex Head 1/4-20 x 3/4"
6	462912	Handlebar Assy., LH (Incl. # 7, 8)
	462913	Handlebar Assy., RH (Incl. #7, 8)
7	43600	Spacer, Bearing
8	48224	Bearing
9	04019-04	Nut, Serrated Flange 3/8-16
10	04001-45	Bolt, Hex Head 3/8-16 x 2"
11	431024	Spacer, Controls
12	04043-04	Flatwasher, 3/8-.391 x .938 x .105 HD
13	04021-09	Nut, Elastic Stop 3/8-16
14	04001-10	Bolt, Hex Head 5/16-18 x 1-1/4"
15	04021-10	Nut, Elastic Stop 5/16-18
16	485842	Linkage Assy., Steering
17	04108-02	Hex Head Socket, 5/16-18 x 1" (36)
	04001-17	Bolt, Hex Head 5/16-18 x 2"
18	43976	Spacer (excludes SVR11-36A)
19	452883	Brake Paddle Weldment, RH (36)
	452842	Brake Paddle Weldment, LH (36)
20	04003-23	Bolt, Carriage 3/8-16 x 1"
21	453139	Bellcrank Weldment, Brake (36)
	452829	Bellcrank Weldment, Brake

Ref. No.	Part No.	Description
22	452882	Brake Paddle Weldment, LH (36)
	452841	Brake Paddle Weldment, LH
23	04001-32	Bolt Hex Head 3/8-16 x 1-1/4"
24	04117-02	Nut, Flange Elastic Stop 3/8-16
25	48100-07	Bushing, Oilite
26	04117-03	Nut, Flange Elastic Stop 1/4-20
27	04001-08	Bolt, Hex Head 5/16-18 x 3/4"
28	427538	Link, Brake Engage (36)
	427539	Link, Brake Engage
29	462914	Brake Lever Assy. - SVR11 (Incl. #30)
30	481548	Grip, Brake Lever
31	04063-12	Key, Woodruff #604 3/16 x 5/8
32	04012-15	Set Screw 1/4-20 x 1/4"
33	04040-03	Flatwasher, 1/4-.281 x .625 x .065
34	452830	Lock Weldment, Neutral
35	04010-12	Screw, #10-32 x 3/4" Taptite
36	04019-02	Nut, Serrated Flange 1/4-20
37	427269	Bracket, Neutral Switch
38	481545	Switch, Interlock (36)
	481637	Switch, Interlock
39	422373	Plate, Threaded
40	04041-07	Flatwasher, 3/8-.391 x .938 x .105

SVR11 FUEL SYSTEM

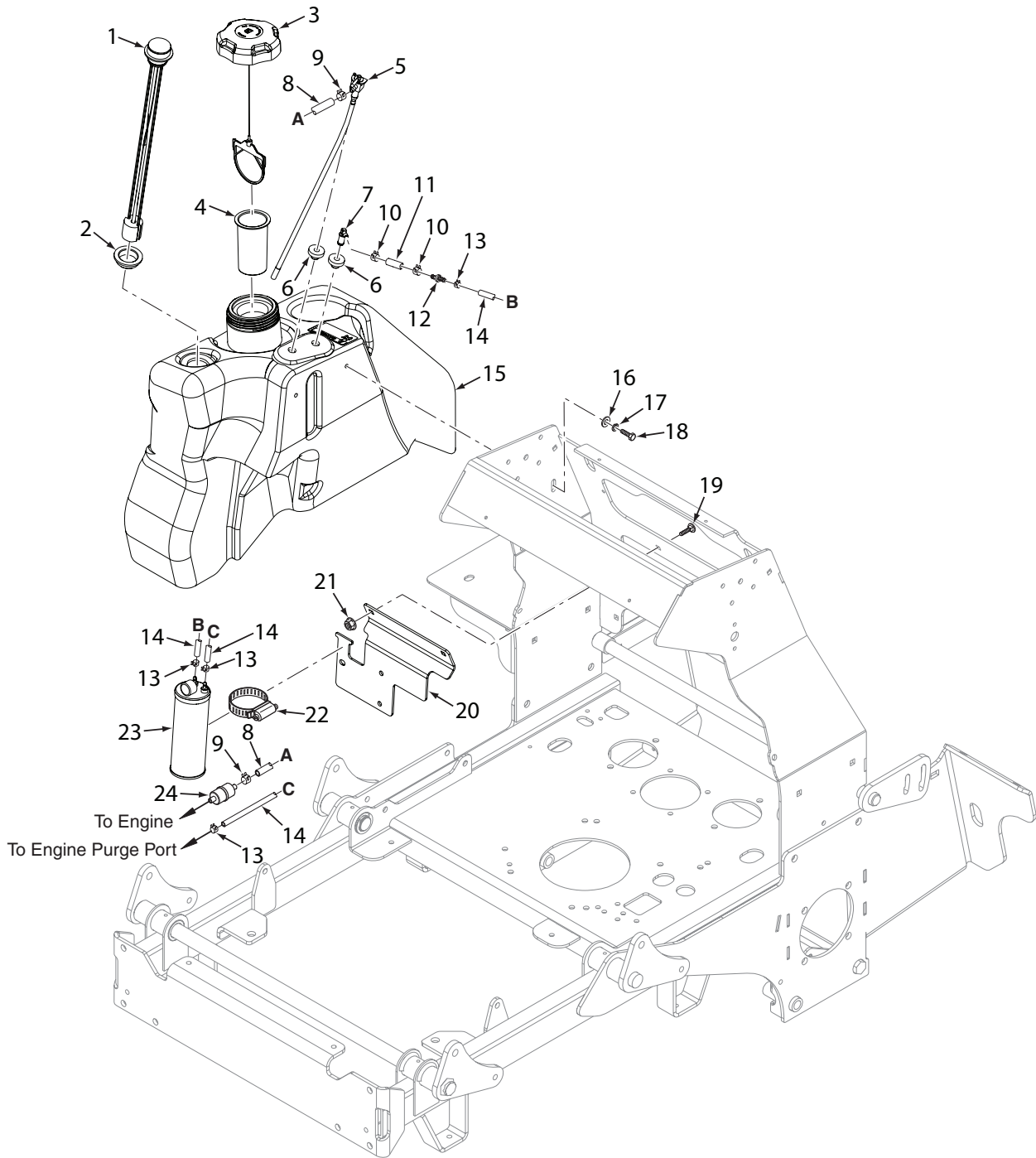

SVRII FUEL SYSTEM

Ref. No.	Part No.	Description
1	485914	Fuel Gauge Assy., 15-1/2" (36) (Incl. #2)
	484246	Fuel Gauge Assy., 16-1/2" (Incl. #2)
2	484242	Seal, Fuel Gauge
3	484286	Fuel Cap, Tethered
	484297-01	Fuel Cap, Tethered - CA models only
4	484079-01	Tube, Fuel Tank Insert
5	485913	Valve, Fuel Shutoff (36)
	483896	Valve, Fuel Shutoff
6	482571	Bushing, .56 Viton
7	485923	Remote Vent
8	483617	Fuel Hose, 1/4" ID (order by inch)
9	48059-01	Clamp, Fuel Hose
10	48059-02	Clamp, Fuel Hose 7/32" ID
11	484347	Hose, Vapor Recovery 1/4" (order by inch)
12	484343-01	Mender, 1/4 x 3/16 w/.02 Hole

Ref. No.	Part No.	Description
13	48059-05	Clamp, Vapor Recovery Hose 3/16"
14	484345	Hose, Vapor Recovery 3/16"
15	462956	Fuel Tank Assy., SVRII-36 (Incl. #1,2,5,6,7)
	462928	Fuel Tank Assy., SVRII (Incl. #1,2,5,6,7)
16	04040-15	Flatwasher, 5/16-.375 x .875 x .083
17	04030-03	Lockwasher, 5/16"
18	04001-08	Bolt, Hex Head 5/16-18 x 3/4"
19	04003-12	Bolt, Carriage 5/16-18 x 3/4"
20	427280	Bracket, Hydro Tank Mounting
21	04019-03	Nut, Serrated Flange 5/16-18
22	48136-17	Clamp, 3-1/2"
23	484342	Carbon Canister
24	*	Fuel Filter

* Order through Engine Manufacturer

SVR11-36A HYDRAULICS AND ENGINE COMPONENTS

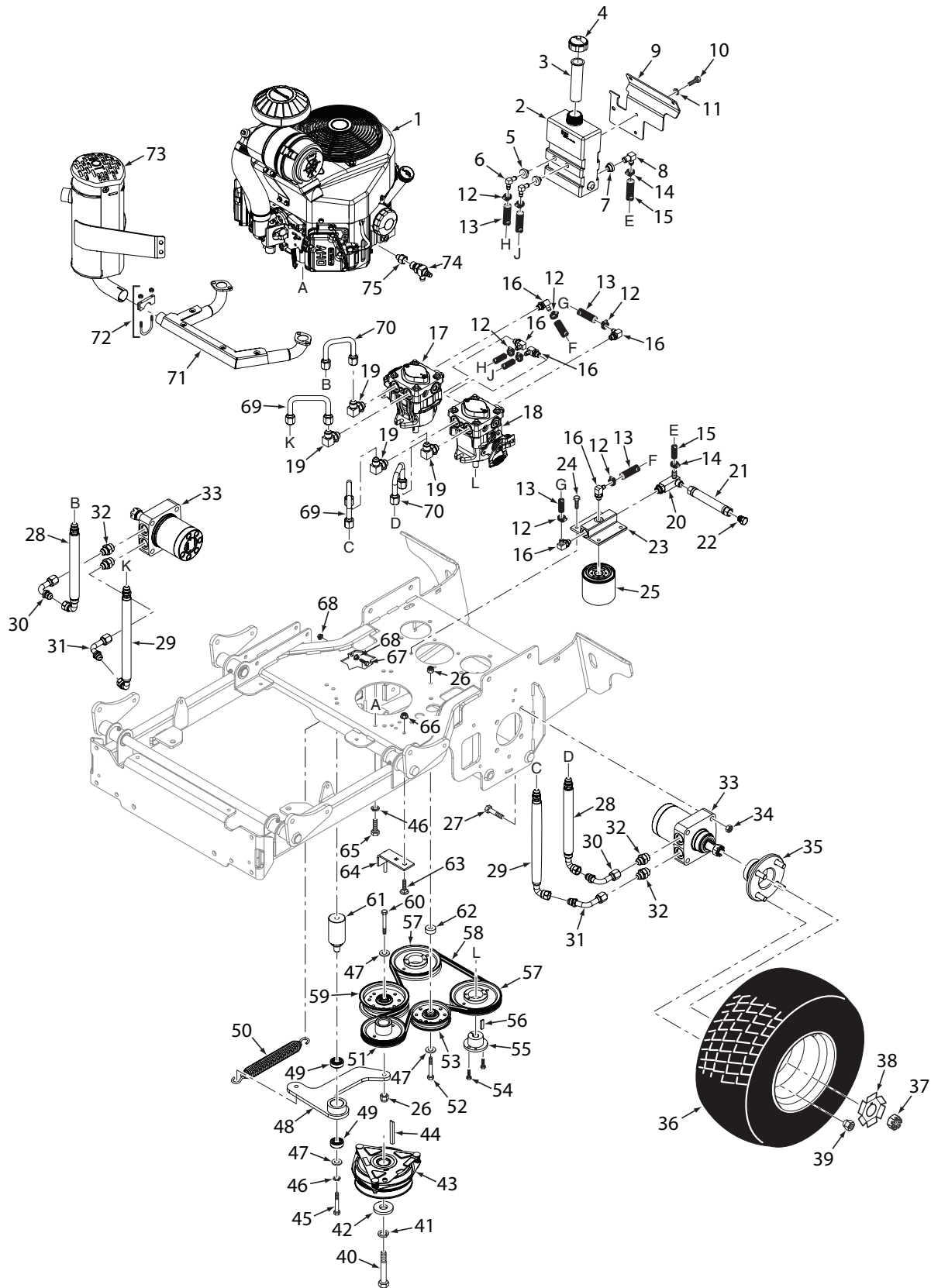

SVRII-36A HYDRAULICS AND ENGINE COMPONENTS

Ref. No.	Part No.	Description	Ref. No.	Part No.	Description
1	*485018	Engine, 15 HP Kawasaki FS	42	04041-28	Flatwasher, 7/16-.469 x 1.75 x .25
	*485019	Engine, 19 HP Kawasaki FX	43	462166	Clutch w/Tag
2	462946	Hydro Tank Assy., SVRII (Incl. #3,5,6,7,8)	44	04063-28	Key, 1/4 x 1/4 x 3-1/2"
3	481507	Insert, Filler Neck	45	04001-51	Bolt, Hex Head 3/8-16 x 3-3/4"
4	481164	Cap, Hydraulic Tank	46	04030-04	Lockwasher, 3/8"
5	482571	Bushing, .56 Viton	47	04043-04	Flatwasher, 3/8-.391 x .938 x 105 HD
6	482572	Fitting, 90 Degree x .38 Hose	48	462983	Idler Arm Assy., Pump Drive - SVRII-36
7	482573	Bushing, .78 Viton	49	48224	Bearing
8	482574	Fitting, 90 Degree x .50 Hose	50	483526	Spring, Transmission Idler
9	427280	Bracket, Hydro Tank Mounting	51	483802	Pulley, 4-3/4" OD - 1.125 Bore
10	04001-08	Bolt, Hex Head 5/16-18 x 3/4"	52	04001-46	Bolt, Hex Head 3/8-16 x 2-1/4"
11	04030-03	Lockwasher, 5/16"	53	483214	Pulley, Idler 4"
12	48136-13	Clamp, Hose	54	04001-172	Bolt, Hex Head 1/4-20 x 1" Gr. 8
13	48811	Hose, 3/8" Pucklock (order by inch)	55	482085	Tapered Hub, 15mm Bore
14	48136-05	Clamp, Hose	56	04063-14	Key, 5 x 5 x 25mm
15	48351	Hose, 1/2" Pushlock (order by inch)	57	482649	Pulley, 5.45 OD - Tapered Bore"
16	482266-01	Elbow, 90 Degree O-Ring	58	485902	Belt, Pump Drive - SVRII-36
17	483863	Pump, SVR	59	484128	Pulley, Idler 4"
18	483862	Pump, SVR	60	04001-39	Bolt, Hex Head 5/16-18 x 2-1/4"
19	48350-02	Elbow, 90 Degree	61	43683	Pivot, Idler
20	485847	Tee, 3/4" O-Ring	62	43720	Spacer, Idler
21	485963	Drain Hose Assy. (Incl. #22)	63	04003-12	Bolt, Carriage 5/16-18 x 3/4"
22	48771-02	Plug, JIC 3/4-16 UNF	64	452162	Anti-Rotation Weldment
23	482417	Filter Head	65	04001-32	Bolt, Hex Head 3/8-16 x 1-1/2"
24	04001-08	Bolt, Hex Head 5/16-18 x 3/4"	66	04019-03	Nut, Serrated Flange 5/16-18
25	48462-01	Filter	67	04001-136	Bolt, Hex Head 3/8-16 x 1-1/2" Gr.8
26	04021-09	Nut, Elastic Stop 3/8-16	68	04019-04	Nut, Serrated Flange 3/8-16
27	04001-52	Bolt, Hex Head 1/2-13 x 2-1/2"	69	484524	Tube Assy., 1/2 x 4" Wide
28	485922	Hose Assy., 11-1/4"	70	484523	Tube Assy., 1/2 x 3" Wide
29	484503	Hose Assy., 13-1/4"	71	*	Exhaust Manifold, 15 HP Kawasaki FS
30	485903	Tube Assy., 1/2 x 2 x 2"	72	484334	Muffler Clamp
31	485904	Tube Assy., 1/2 x 2 x 3-1/4"	73	484620	Muffler, Kawasaki
32	48572-02	Tube, Union 1/2 x 5/8"	74	485930	Oil Drain, SVRII-36
33	483388	Wheel Motor		483280	Tubing, Oil Drain (now shown)
	04063-40	Key, Woodruff 3/16 x 3/4" (not shown)			(order by inch)
34	04021-19	Nut, Center Lock 1/2-13	75	485960	Fitting, M14 to M20 Male
35	462275	Wheel Hub Assembly			
	04008-01	Wheel Stud			
36	485920	Wheel Assy., 20 x 8 - 10			
	485917	Tire, 20 x 8 - 10			
	485918	Rim w/ Valve			
37	48679	Hex Castle Nut, 3/4-28			
38	422214	Lockwasher, Wheel Motor			
39	04028-02	Wheel Nut			
40	04102-03	Bolt, Hex Head 7/16-20 x 2-1/4" w/ Patch			
41	04030-05	Lockwasher, 7/16"			

* Order through Engine Manufacturer

SVR11-48V / 52V / 61V HYDRAULICS AND ENGINE COMPONENTS

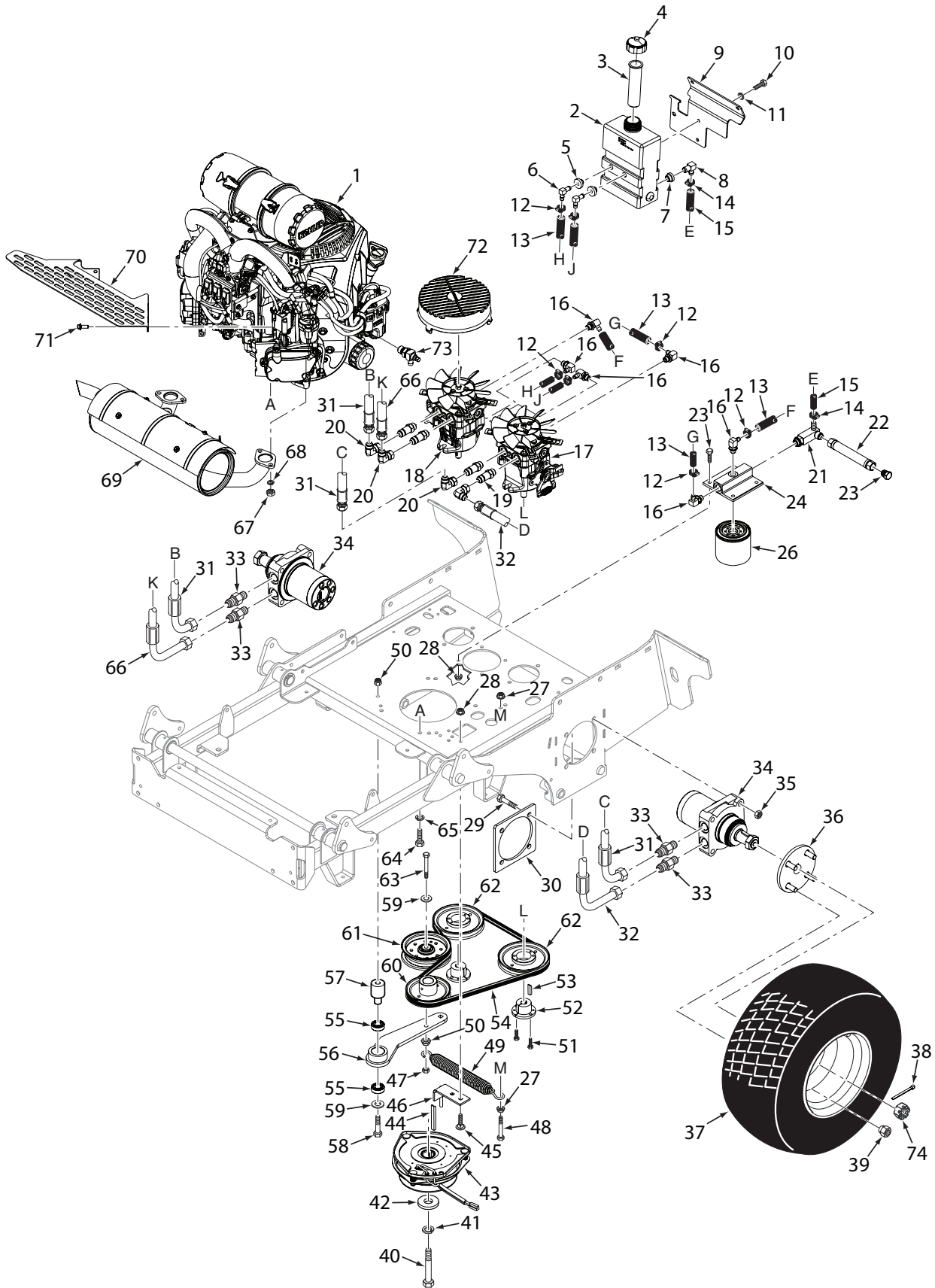

Section 8

SVRII-48V / 52V / 61V HYDRAULICS AND ENGINE COMPONENTS

Ref. No.	Part No.	Description
1	*485020	Engine, 22 HP Kawasaki FX
	*485021	Engine, 23 HP Kawasaki FX
	*485134	Engine, 25 HP Kohler EFI
	*485022	Engine, 25 HP Kawasaki FX
	*485891	Engine, 29 HP Kohler EFI
2	462946	Hydro Tank Assy., SVRII (Incl. #3,5,6,7,8)
3	481057	Insert, Filler Neck
4	481164	Cap, Hydro Tank
5	482571	Bushing, .56 Viton
6	482572	Fitting, 90 Degree x .38 Hose
7	482573	Bushing, .78 Viton
8	482574	Fitting, 90 Degree x .50 Hose
9	427280	Bracket, Hydro Tank Mounting
10	04001-08	Bolt, Hex Head 5/16-18 x 3/4"
11	04030-03	Lockwasher, 5/16"
12	48136-13	Clamp, Hose
13	48811	Hose, 3/8" Pushlock (order by inch)
14	48136-05	Clamp, Hose
15	48351	Hose, 1/2" Pushlock (order by inch)
16	482266-01	Elbow, 90 Degree - O-Ring
17	485838	Pump, LH - SVRII
18	485839	Pump, RH - SVRII
19	485830	Union, O-Ring to JIC
20	481203-02	Elbow, JIC Swivel
21	485847	Tee, 3/4 O-Ring
22	485870	Drain, Hose Assembly (Incl. #23)
23	48771-02	Plug, JIC 3/4-16 UNF
24	482417	Filter Head
25	04001-08	Bolt, Hex Head 5/16-18 x 3/4"
26	48462-01	Filter
27	04019-04	Nut, Serrated Flange 3/8-16
28	04019-03	Nut, Serrated Flange 5/16-18
29	04001-52	Bolt, Hex Head 1/2-13 x 2-1/2"
30	423279	Plate, Motor Backing
31	485792	Hose Assy., 27-1/2"
32	484509	Hose Assy., 15-1/4"
33	48572-02	Tube, Union 1/2 x 5/8
34	485788	Wheel Motor, SVRII
	04063-25	Key, Woodruff 5/16 x 1" (not shown)
35	04021-19	Nut, Center Lock 1/2-13
36	462999	Wheel Hub Assy., SVRII
	04008-01	Serrated Bolt, 1/2-20 x 1.563
37	485851	Wheel Assy., 24 x 9.5 - 12 (4-Ply) (48 / 52)
	484104	Tire, 24 x 9.5 - 12 (4-Ply)
	485852	Rim w/Stem
	485933	Wheel Assy., 24 x 12 - 12 (4-Ply) (61)
	481852	Tire, 24 x 12 - 12 (4-Ply)
	485934	Rim w/Stem
38	04061-06	Pin, Cotter 9/64 x 1"
39	04028-02	Wheel Nut
40	04102-03	Bolt, Hex Head 7/16-20 x 2-1/4" w/ Patch
41	04030-05	Lockwasher, 3/8"

Ref. No.	Part No.	Description
42	04041-28	Flatwasher, 7/16-.469 x 1.75 x .25
43	462166	Clutch w/Tag GT2.5-FE02 (48 / 52)
	462339	Clutch w/Tag GT3.5-FE05 (61)
44	04063-28	Key, 1/4 x 1/4 x 3-1/2"
45	04003-12	Bolt, Carriage 5/16-18 x 3/4"
46	452162	Anti-Rotation Bracket
47	04021-05	Nut, Center Lock 3/8-16
48	04001-54	Bolt, Hex Head 3/8-16 x 3"
49	483526	Spring, Transmission Idler
50	04021-09	Nut, Elastic Stop 3/8-16
51	04001-172	Bolt, Hex Head 1/4-20 x 1" Gr.8
52	482085	Tapered Hub, 15mm Bore
53	04063-14	Key, 5 x 5 x 25mm
54	483520	Belt, Transmission
55	48224	Bearing
56	462969	Idler Arm Assy. (Incl. #55)
57	43683	Pivot, Idler
58	04001-62	Bolt, Hex Head 3/8-16 x 3-1/4"
59	04043-04	Flatwasher, 3/8-.391 x .938 x .105 HD
60	483802	Pulley, 4.75" OD - 1.125 Bore
61	483213	Pulley, 4-1/2" Idler
62	482649	Pulley, 5.45" OD - Tapered Bore
63	04001-161	Bolt, Hex Head 3/8-16 x 2-3/4" Full Thread
64	04001-32	Bolt, Hex Head 3/8-16 x 1-1/4" (Kawasaki)
	04011-07	Bolt, Hex Head Self-Tap 3/8-16 x 1-1/4" (Kohler x3 - 25EFI, Kohler x4 - 29EFI)
	04001-11	Bolt, Hex Head 5/16-18 x 1-1/2" (Kohler x1)
	04031-03	Lockwasher, 5/16" Ext. Tooth (Kohler x1)
	04019-03	Nut, Serrated Flange 5/16-18 (Kohler x1)
65	04030-04	Lockwasher, 3/8"
66	485791	Hose Assy., 30"
67	04025-04	Nut, N8-1.25 (Kawasaki)
	04130-01	Lock Nut, M8-1.25 -8H (Kohler)
68	04033-01	Lockwasher, M8 Spring (Kawasaki)
69	485800	Muffler, Kawasaki FX - SVRII
	485799	Muffler, Kohler CV-EFI - SVRII
	485896	Muffler, Kawasaki FX801 - SVRII
	485887	Muffler, Kohler, 29 EFI - SVRII
70	427380	Heatshield, Muffler - Kawasaki FX - SVRII
	427437	Heatshield, Muffler - Kawasaki FX801 - SVRII
	427432	Heatshield, Muffler - Kohler 29 EFI - SVRII
71	04119-02	Bolt, M8-1.25 x 20 Flanged HD
	04001-08	Bolt, Hex Head 5/16-18 x 3/4" - 23HP FX
	04040-04	Flatwasher, 5/16-.344 x .688 x .065
	04019-03	Nut, Serrated Flange 5/16-18
72	485564	Fan Cover, Pump
73	484089	Oil Drain, M20 Thread (Kawasaki)
	482510	Oil Drain, 3.3" (Kohler 25HP-EFI)
	*	Oil Drain (Kohler 29HP-EFI p/n 25 462 13)
	483280	Tubing, Oil Drain (not shown) (order by inch)
74	48680	Nut, Hex Castle

* Order through Engine Manufacturer

** Not available through Scag

SVRII-36A ELECTRICAL SYSTEM

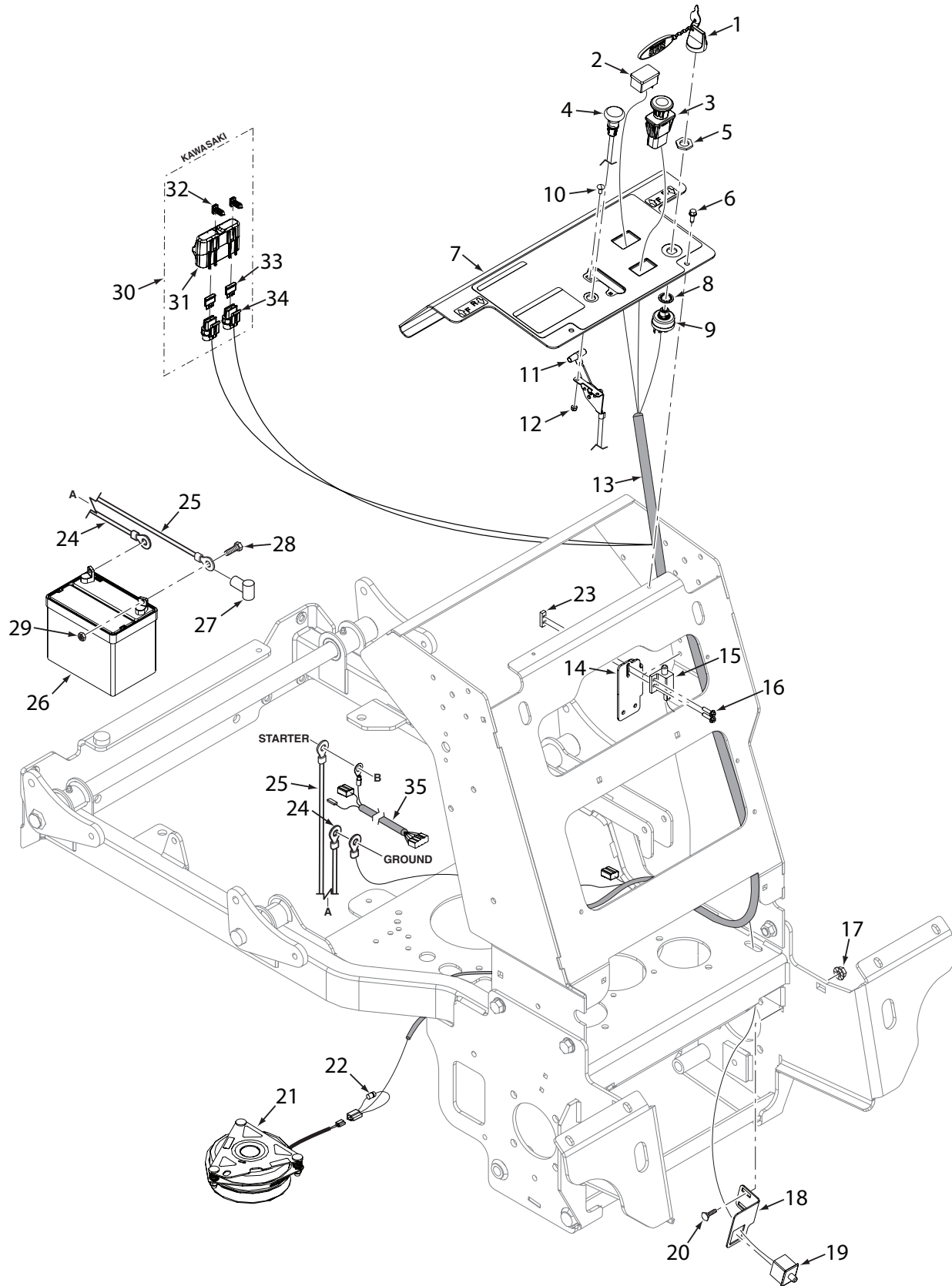

SVRII-36A ELECTRICAL SYSTEM

Ref. No.	Part No.	Description
1	462069	Key Assy. w/Fob
2	484565	Hourmeter, Inductive
3	483957	Switch, PTO
4	483976	Choke Control
5	48017-04	Nut, Special 5/8-32
6	04011-14	Screw, 1/4-20 x 3/4" Taptite
7	462985	Instrument Panel w/Decal - SVRII
8	48017-03	Lockwasher, 5/8" Internal Tooth
9	48798	Switch, Key
10	04003-43	Bolt, Carriage #10-24 x 1/2"
11	483975	Throttle Control
12	04021-26	Nut, Elastic Stop #10-24
13	485938	Wire Harness, SVRII-36
14	427269	Bracket, Neutral Switch
15	481545	Switch, Interlock - DPDT
16	04010-12	Screw, #10-24 x 3/4" Taptite
17	04019-02	Nut, Serrated Flange 1/4-20
18	427481	Switch Bracket, Operator Presence
19	484497	Switch, Double Pole - N.O. / N.O.
20	04003-02	Nut, Serrated Flange 1/4-20
21	462166	Clutch w/Tag GT2.5-FE02
22	483958	Diode, 600V - 6A
23	422373	Plate, Threaded
24	48029-24	Cable, Battery - Black 39"
25	48029-30	Cable, Battery - Red 44" w/Braid
26	483665	Battery, 350 CCA (not available through Scag)
27	48126	Rubber Boot
28	04001-01	Bolt, Hex Head 1/4-20 x 3/4"
29	04020-02	Nut, 1/4-20
30	483642	Double Fuse Assy. (Incl. #31, 32, 33, 34)
31	483571	Cover, Sealed Double
32	482588	Clip, Wire
33	48298	Fuse, 20 Amp
34	483629	Fuse Holder
35	482543	Wire Harness Adaper - Kawasaki

SVR11-36A ELECTRICAL SYSTEM - RECOIL START MODELS

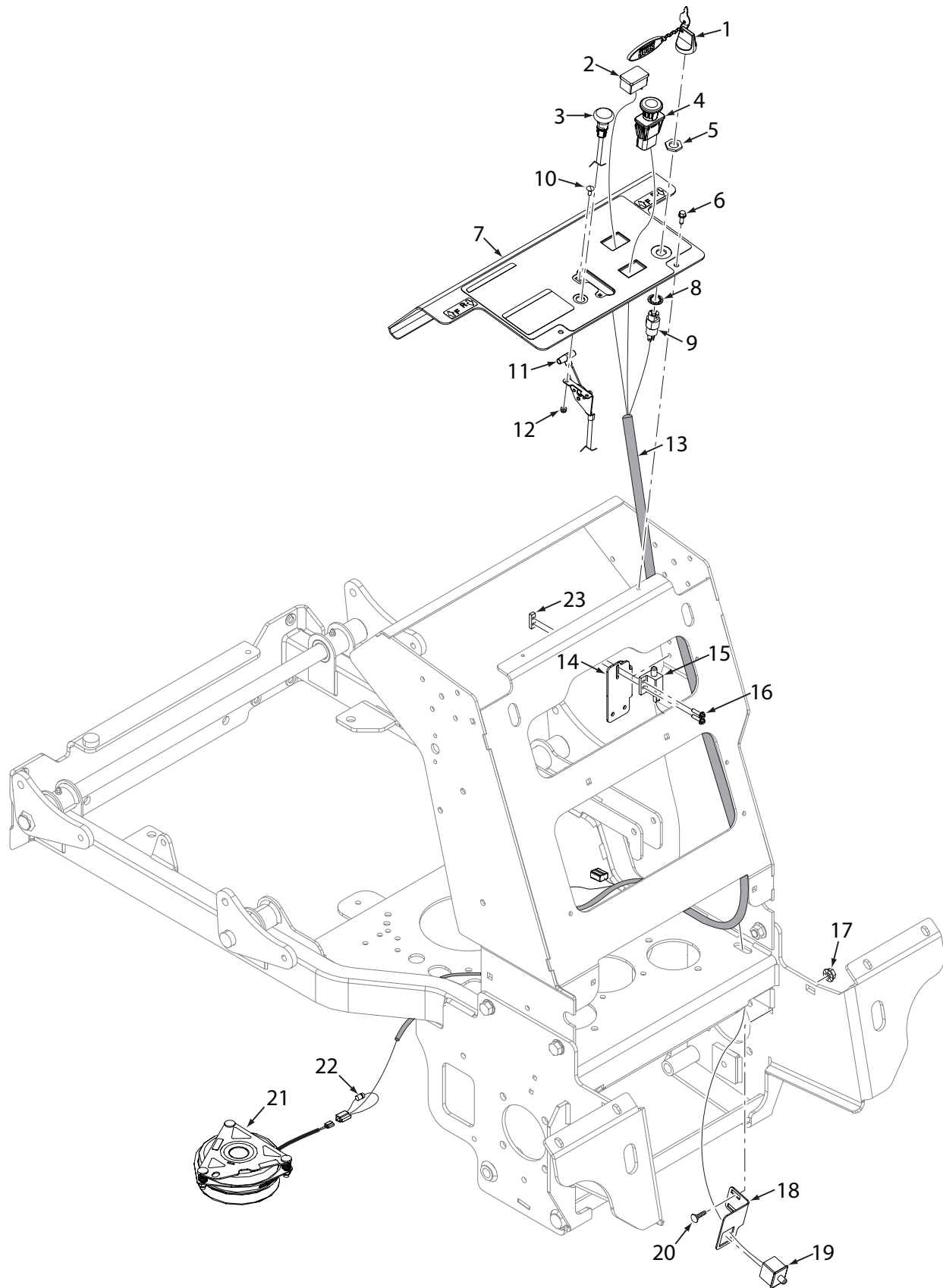

SVRII-36A ELECTRICAL SYSTEM - RECOIL START MODELS

Ref. No.	Part No.	Description
1	462069	Key Assy., w/Fob
2	484566	Hourmeter
3	483976	Choke Control
4	483957	Switch, PTO
5	48017-04	Nut, Special 5/8-32
6	04011-14	Screw, 1/4-20 x 3/4" Taptite
7	462985	Instrument Panel w/Decal - SVRII36
8	48017-03	Lockwasher, 5/8" Internal Tooth
9	48609	Switch, Key
10	04003-43	Bolt, Carriage #10-24 x 1/2"
11	483975	Throttle Cable
12	04021-26	Nut, Elastic Stop #10-24
13	485960	Wire Harness, SVRII Recoil Start
14	427269	Bracket, Neutral Switch
15	481545	Switch, Interlock
16	04010-12	Screw, #10-32 x 3/4" Taptite
17	04019-02	Nut, Serrated Flange 1/4-20
18	427481	Switch Bracket, Operator Presence
19	484497	Switch, Double Pole - N.O. / N.O.
20	04003-02	Bolt, Carriage 1/4-20 x 3/4"
21	462166	Clutch w/Tag GT2.5-FE02
22	483958	Diode, 600V - 6A
23	422373	Plate, Threaded

SVR11-48V / 52V / 61V ELECTRICAL SYSTEM

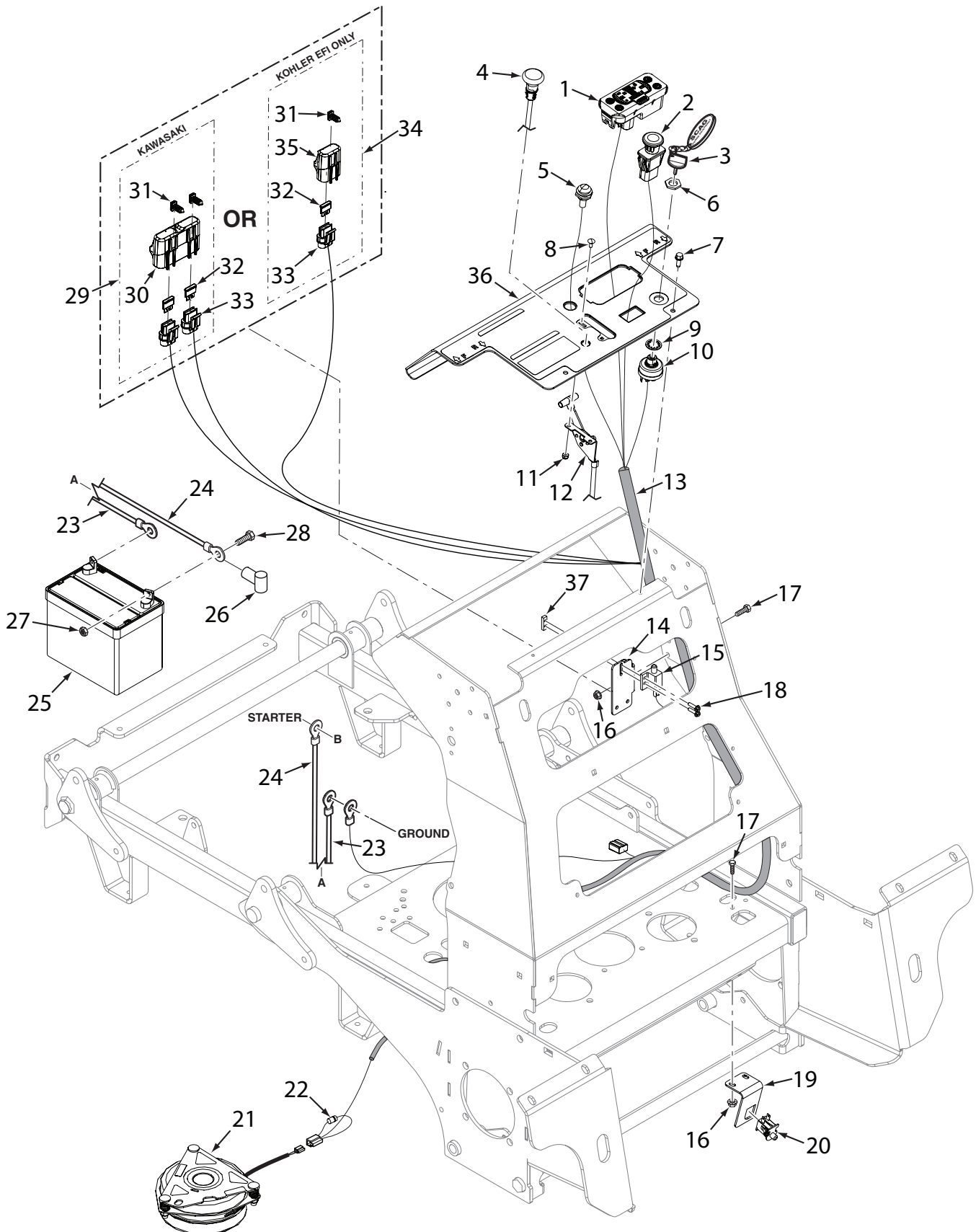

SVRII-48V / 52V / 61V ELECTRICAL SYSTEM

Ref. No.	Part No.	Description
1	484721	Tiger Eye, Cluster Gauge
2	483957	Switch, PTO
3	462069	Key Assy., w/Fob
4	483976	Choke Control (excludes EFI models)
5	481182	Indicator Light (EFI models only)
6	48017-04	Nut, Special 5/8-32
7	04011-14	Screw, 1/4-20 x 3/4" Taptite
8	04003-43	Bolt, Carriage #10-24 x 1/2"
9	48017-03	Lockwasher, 5/8" Internal Tooth
10	48798	Switch, Key
11	04021-26	Nut, Elastic Stop #10-24
12	483975	Throttle Control
13	485875	Wire Harness, SVRII
	485822	Wire Harness, SVRII-EFI
14	427269	Bracket, Neutral Switch
15	481637	Switch, N/O
16	04019-02	Nut, Serrated Flange 1/4-20
17	04001-01	Bolt, Hex Head 1/4-20 x 3/4"
18	04010-12	Screw, #10-32 x 3/4" Taptite
19	427249	Switch Bracket, Operator Presence
20	48717	Switch
21	462166	Clutch w/Tag GT2.5-FE02 (48 / 52)
	462339	Clutch w/Tag GT3.5--FE05 (61)
22	483958	Diode, 600V - 6A
23	48029-24	Battery Cable, 39" Black
24	48029-30	Battery Cable, 44" Red w/Braid
25	483665	Battery, 350 CCA (not available through Scag)
26	48126	Rubber Boot
27	04020-02	Nut, 1/4-20
28	04001-01	Bolt, Hex Head 1/4-20 x 3/4"
29	483642	Double Fuse Assy,\.\. (Incl. #30, 31, 32, 33)
30	483571	Cover, Sealed Double
31	482588	Clip, Wire
32	48298	Fuse, 20 Amp
33	483629	Fuse Holder
34	485739	Single Fuse Assy. (Incl. #31, 33, 35)
35	483643	Cover, Sealed Single
36	462970	Control Panel w/Decal
37	422373	Plate, Threaded

SVRII-36A HYDRAULIC PUMP

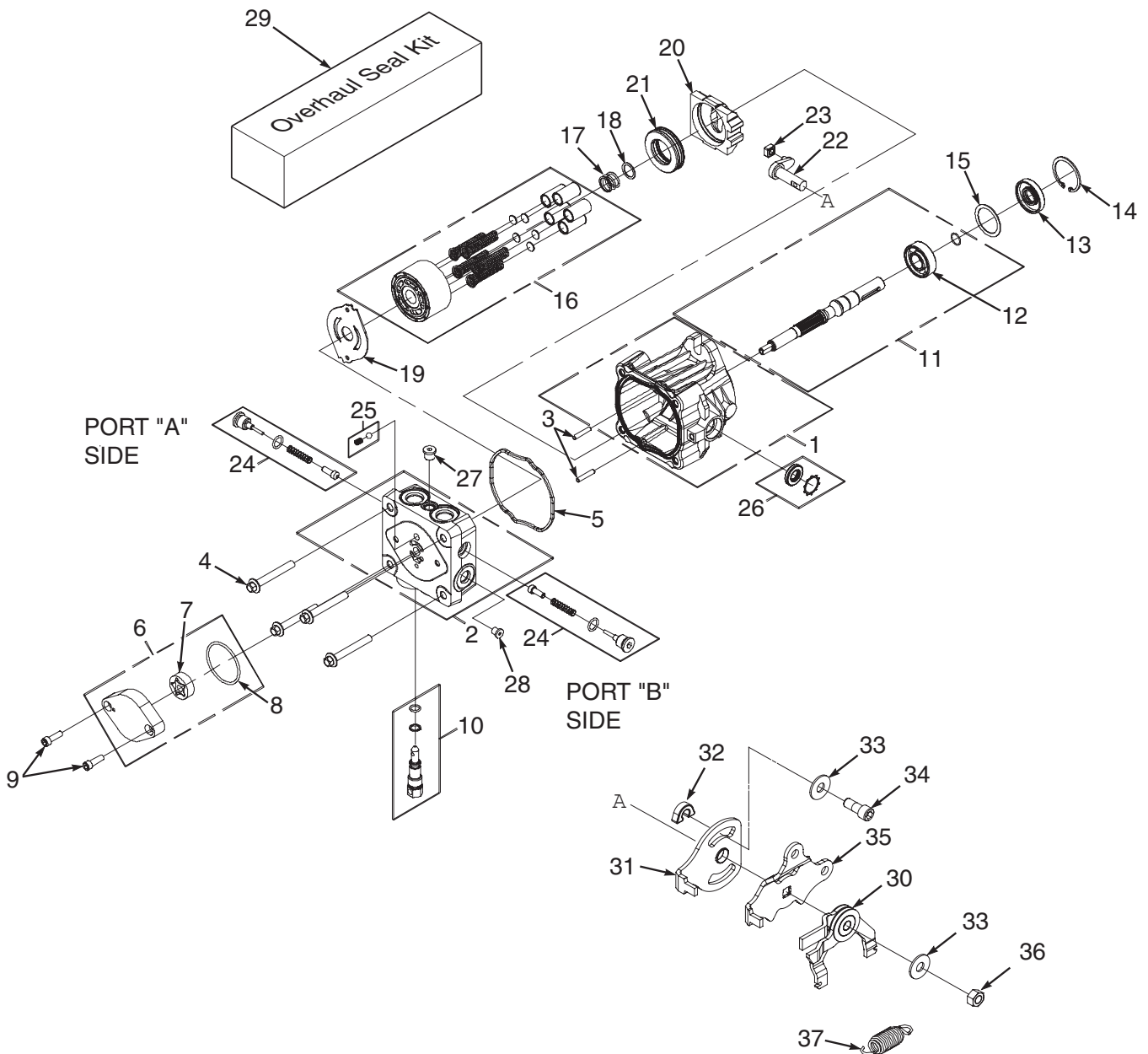

SVRII-36A HYDRAULIC PUMP

Ref. No.	Part No.	Description
1	HG72598	Kit, Housing
2	HG70517	Kit, End Cap
3	HG50641	Pin, .219 x 1.000
4	HG50969	Bolt, M8 X 1.25 mm
5	HG54022	Gasket, Housing
6	HG2513027	Kit, Charge Pump
7	HG50273	Gerotor Assembly
8	HG9004101-1340	O-Ring
9	HG5095	Screw, Socket Head M6 X 1.0 - 20mm
10	HG2513030	Kit, By-Pass
11	HG70521	Kit, Shaft
12	HG50315	Bearing
13	HG51161	Seal, 17 x 40 x 7 Lip
14	HG50329	Ring, Retaining .156 Internal
15	HG50951	Washer, 1.23 x 1.57 x .04
16	HG70331	Kit, Block 10cc
17	HG2003014	Spring, Block
18	HG2003017	Washer, .59 x .79 x .04
19	HG51444	Plate, Valve 10cc
20	HG2003087	Swashplate
21	HG50551	Bearing, Thrust
22	HG52866	Arm, Trunion
23	HG2000015	Slot Guide
24	HG2510027	Kit, Check Valve (.031 Orifice)
25	HG70402	Kit, Charge Relief
26	HG2513043	Kit, Seal
27	HG9005110-4400	Plug, 7/16-20
28	HG9005110-5600	Plug, 9/16-18
29	HG70525	Seal Kit
30	HG52413	RTN Assembly
31	HG51391	Arm, Return
32	HG51561	Spacer
33	HG44130	Washer
34	HG51400	Screw, 5/16-24 x 3/4" w/Patch
35	HG51394	Control Arm
36	HG52506	Nut, Center Lock 5/16-24 UNF
37	HG52401	Spring, External

SVRII-48V / 52V / 61V HYDRAULIC PUMP

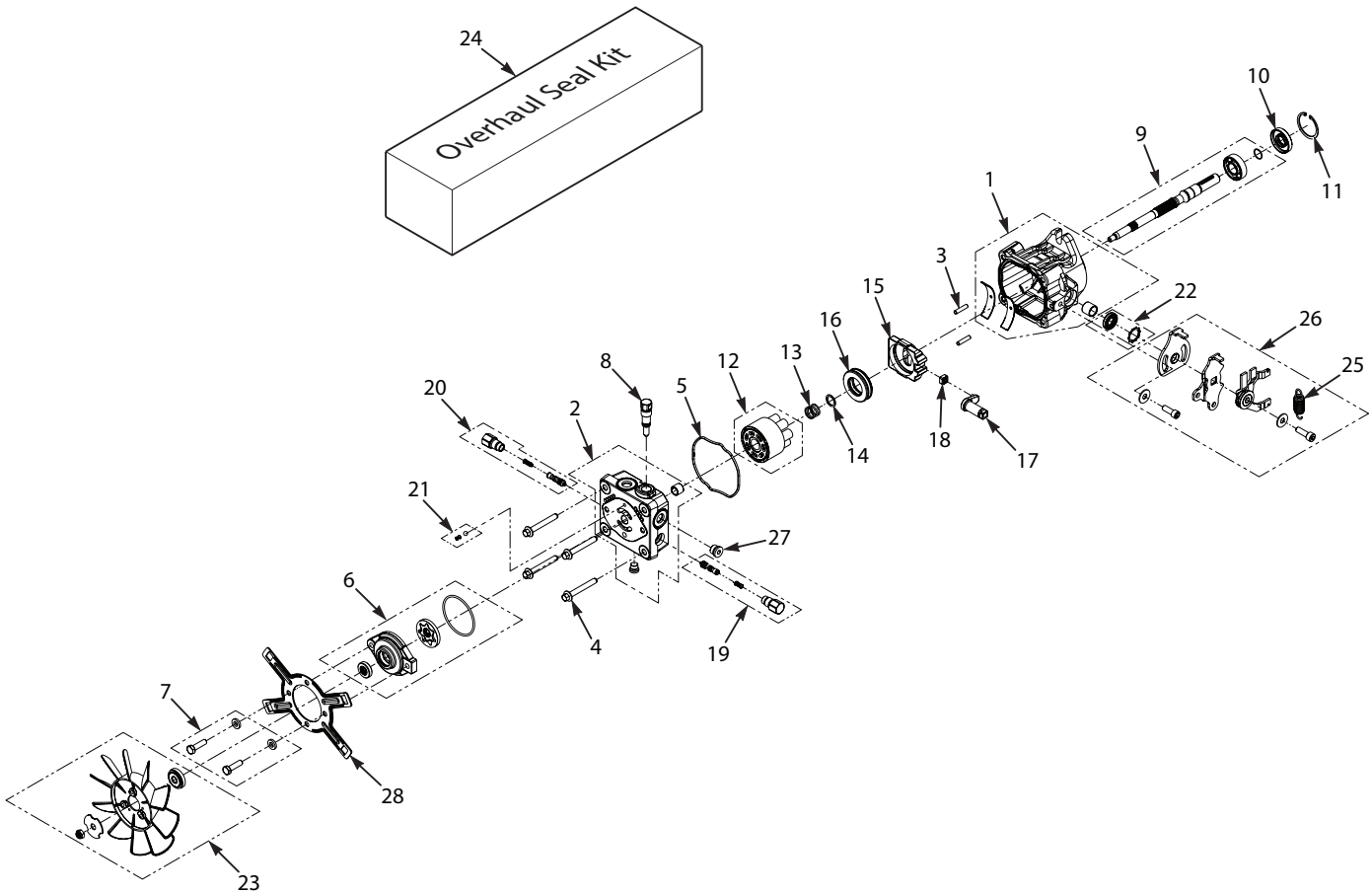

SVRII-48V / 52V / 61V HYDRAULIC PUMP

Ref. No.	Part No.	Description
1	HG72267	Kit, Housing
2	HG72011	Kit, End Cap
3	HG50641	Pin, .219 x 1.000
4	HG50969	Bolt, M8 X 1.25 mm
5	HG54022	Gasket, Housing
6	HG70622	Kit, Charge Pump
7	HG72254	Kit, Charge Pump Bolts
8	HG2513030	By-Pass Valve
9	HG70620	Kit, Shaft
10	HG51161	Seal, 17 x 40 x 7 Lip
11	HG50329	Ring, Retaining .156 Internal
12	HG71971	Kit, Block 12cc
13	HG2003014	Spring, Block
14	HG2003017	Washer, .59 x .79 x .04
15	HG53998	Swashplate
16	HG53502	Bearing, Thrust
17	HG52866	Trunnion Arm
18	HG2000015	Slot Guide
19	HG70838	Kit, Shock Valve - 160 Bar (.031 Orifice)
20	HG70838	Kit, Shock Valve - 160 Bar (.031 Orifice)
21	HG70403	Kit, Charge Relief
22	HG2513043	Kit, Seal - Trunnion Arm
23	HG70811	Fan Assembly
24	HG70525	Seal Kit
25	HG52401	Spring
26	HG71716	Kit, RTN
27	HG9005110-5600	Plug, 9/16-18
28	HG52355	Bracket, 7"

REPLACEMENT DECALS AND INFORMATION PLATES



1



2

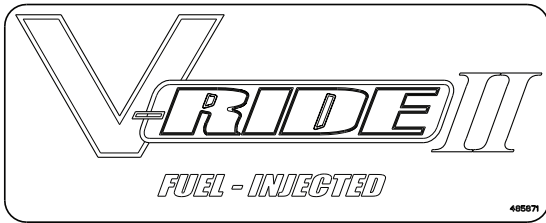

3



4

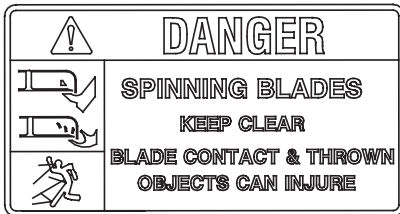

5



6

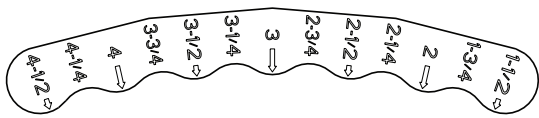

7

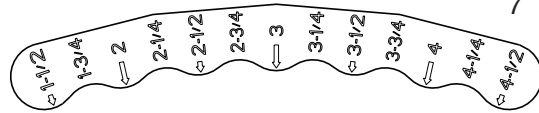

13

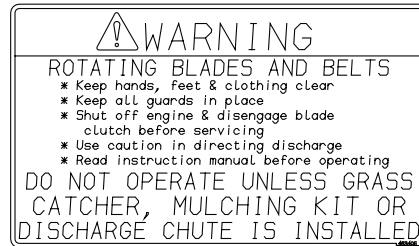

8

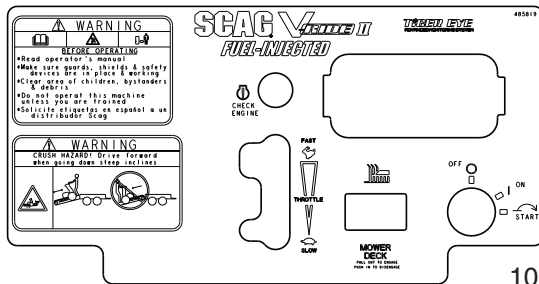

10



9

Replacement Parts Numbers VELOCITY III
Always use original Scag replacement parts for top machine performance and to maintain factory warranty.

Belt, Pump Drive (36")	485902	Standard Blade, Cutter (36" & 52")	482876
Belt, Pump Drive (46", 52", & 61")	485920	Standard Blade, Cutter (48")	482877
Belt, Cutter Deck Drive (36")	485938	Standard Blade, Cutter (51")	482881
Belt, Cutter Deck Drive (48")	485966	Spindle Grease: Mobilgrease XHP™ 222	
Belt, Cutter Deck Drive (52")	484100	Exxon Mobil Titan EP	
Belt, Cutter Deck Drive (61")	485880	Exxon Mobil Ultra EP2	
		Filter, Hydraulic	48462-01

See your authorized Scag dealer for engine part numbers.
pn 485974

11

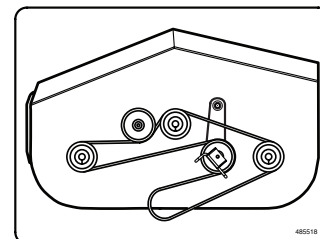

12

REPLACEMENT DECALS AND INFORMATION PLATES

Ref. No.	Part No.	Description
1	483402	Decal, Warning - Belt Cover
2	483405	Decal, Warning
3	485872	Decal, Belt Cover
	485871	Decal, Belt Cover - EFI
4	483059	Decal, 36A
	483199	Decal, 48V
	483200	Decal, 52V
	483201	Decal, 61V
5	483407	Decal, Spinning Blades
6	485403	Decal, Metalcraft - USA
7	485798	Decal, Deck Height - Outer
8	483406	Decal, Warning - Knives
9	484453	Decal, Scag Heavy Duty Commercial
10	485910	Decal, Instrument Panel - SVRII36A
	485911	Decal, Instrument Panel - SVRII36A - Recoil Start
	485877	Decal, Instrument Panel - SVRII
	485819	Decal, Instrument Panel - SVRII-EFI
11	485974	Decal, SVRII Replacement Parts
12	485517	Decal, Belt Routing - SVRII36A
	485518	Decal, Belt Routing - SVRII48V, SVRII52V & SVRII61V
13	485826	Decal, Deck Height - Inner

SVR11-36 ELECTRICAL SCHEMATIC - RECOIL START MODELS (shown with Key Off, PTO Off, Park Brake Applied, OPC Disengaged)

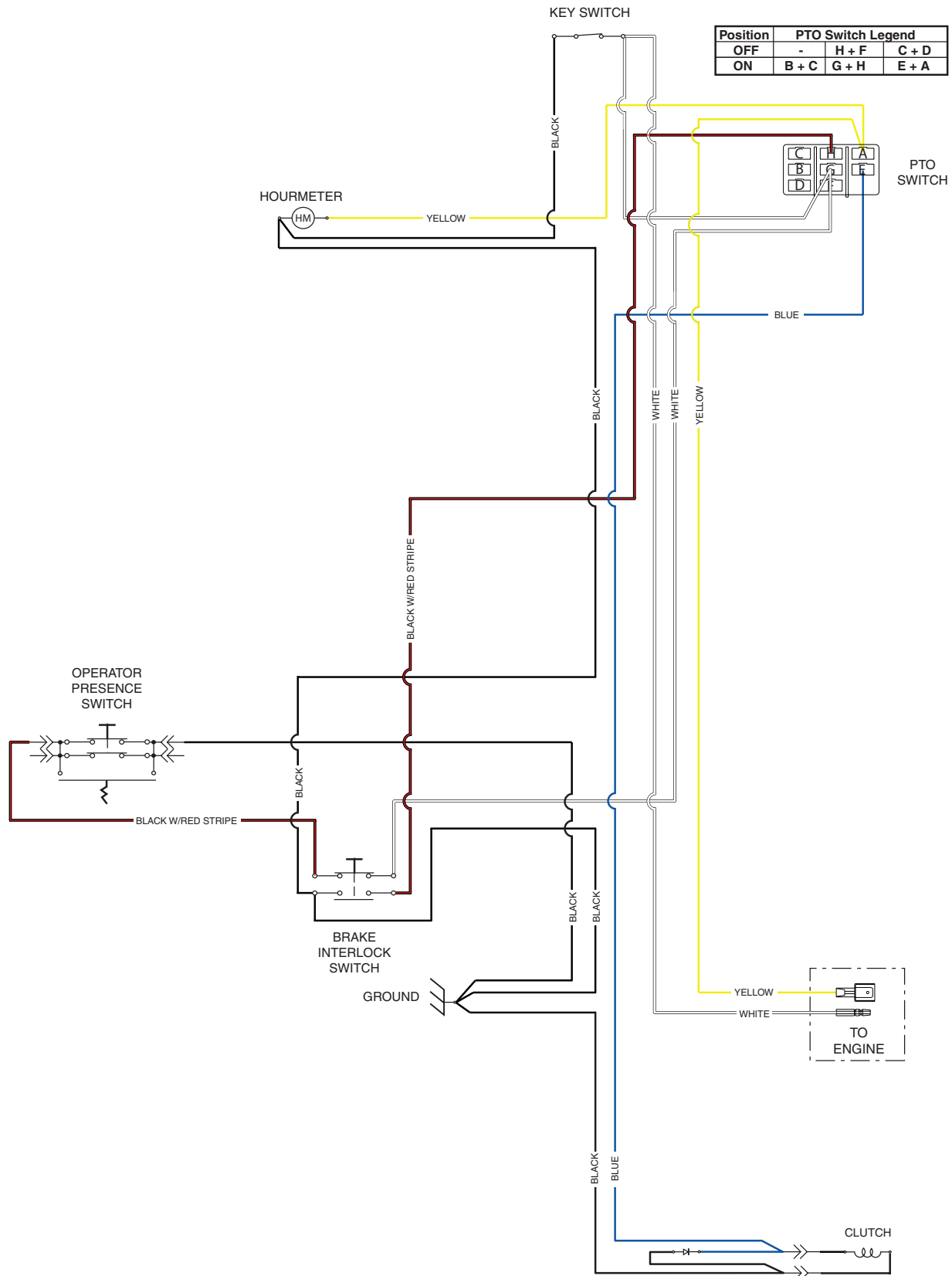

SVRII-36 ELECTRICAL SCHEMATIC

(shown with Key Off, PTO Off, Park Brake Applied, OPC Disengaged)

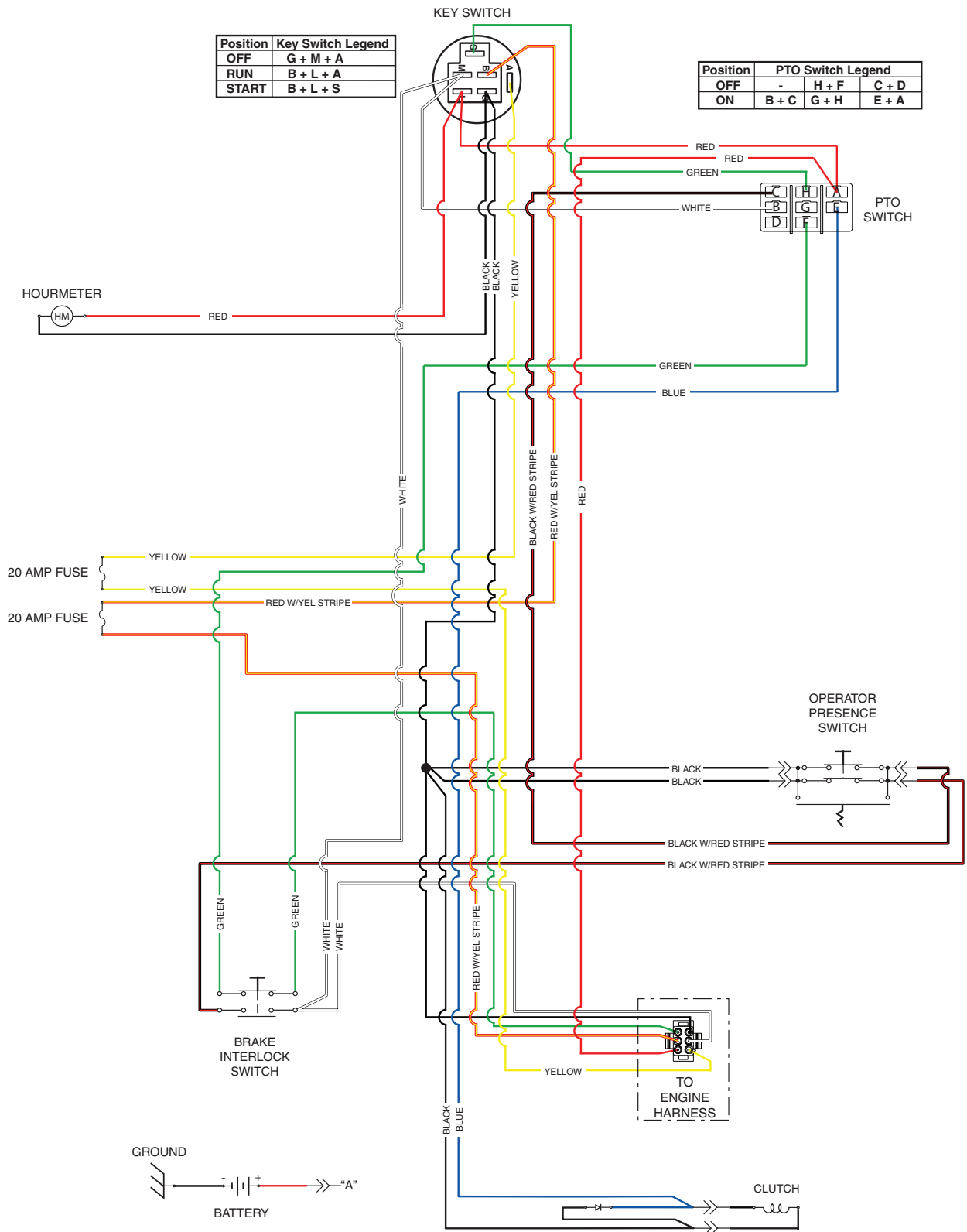

SVR11 ELECTRICAL SCHEMATIC - ELECTRIC START MODELS (shown with Key Off, PTO Off, Park Brake Applied, OPC Disengaged)

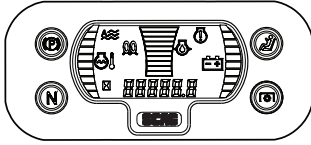

Position	Key Switch Legend
OFF	G + M + A
RUN	B + L + A
START	B + L + S

Position	PTO Switch Legend		
OFF	-	H + F	C + D
ON	B + C	G + H	E + A

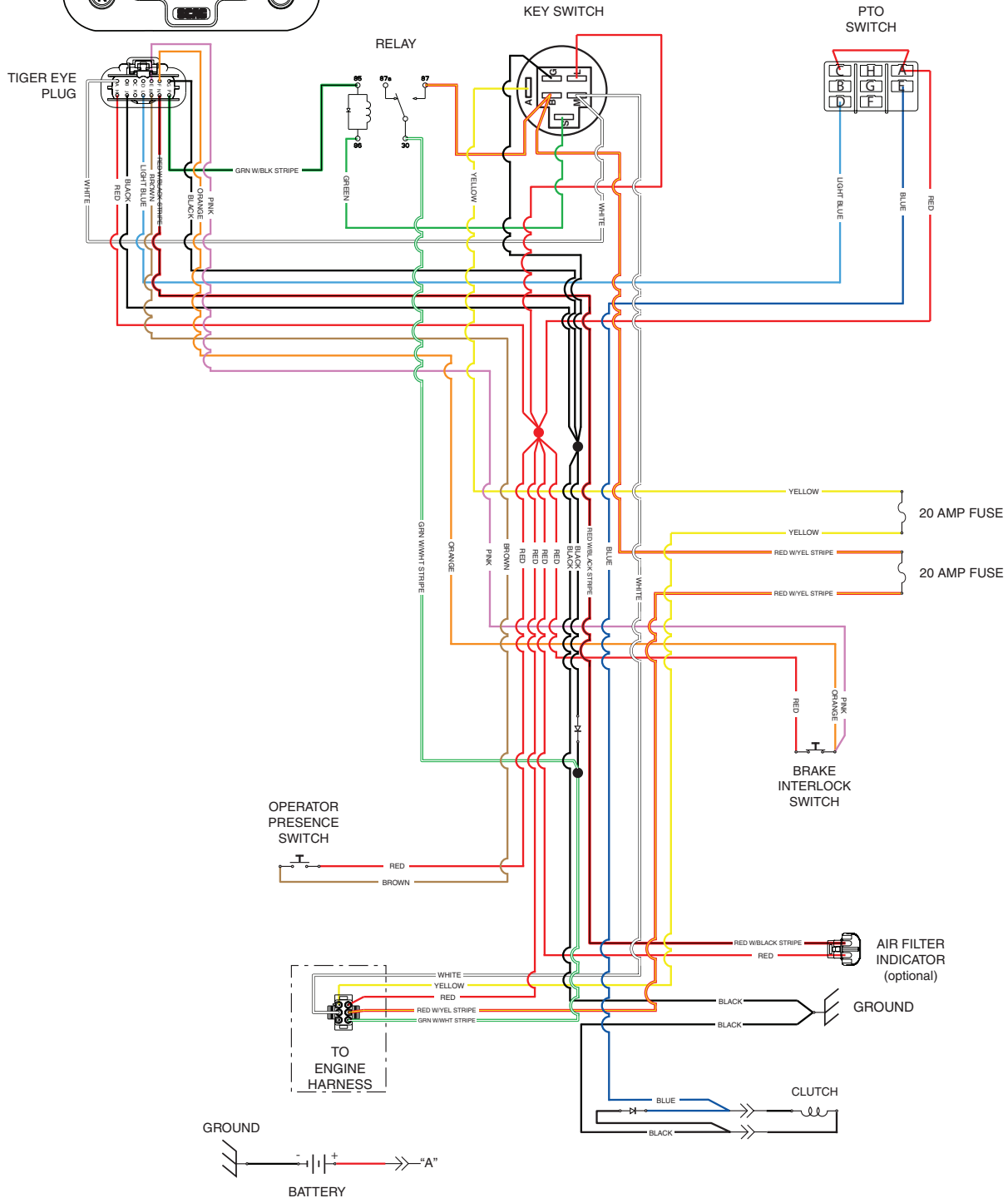

SVRII-EFI ELECTRICAL SCHEMATIC (shown with Key Off, PTO Off, Park Brake Applied, OPC Disengaged)

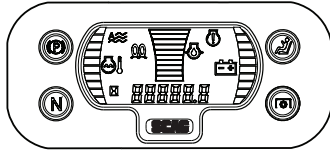

Position	Key Switch Legend
OFF	G + M + A
RUN	B + L + A
START	B + L + S

Position	PTO Switch Legend	
OFF	-	H + F C + D
ON	B + C	G + H E + A

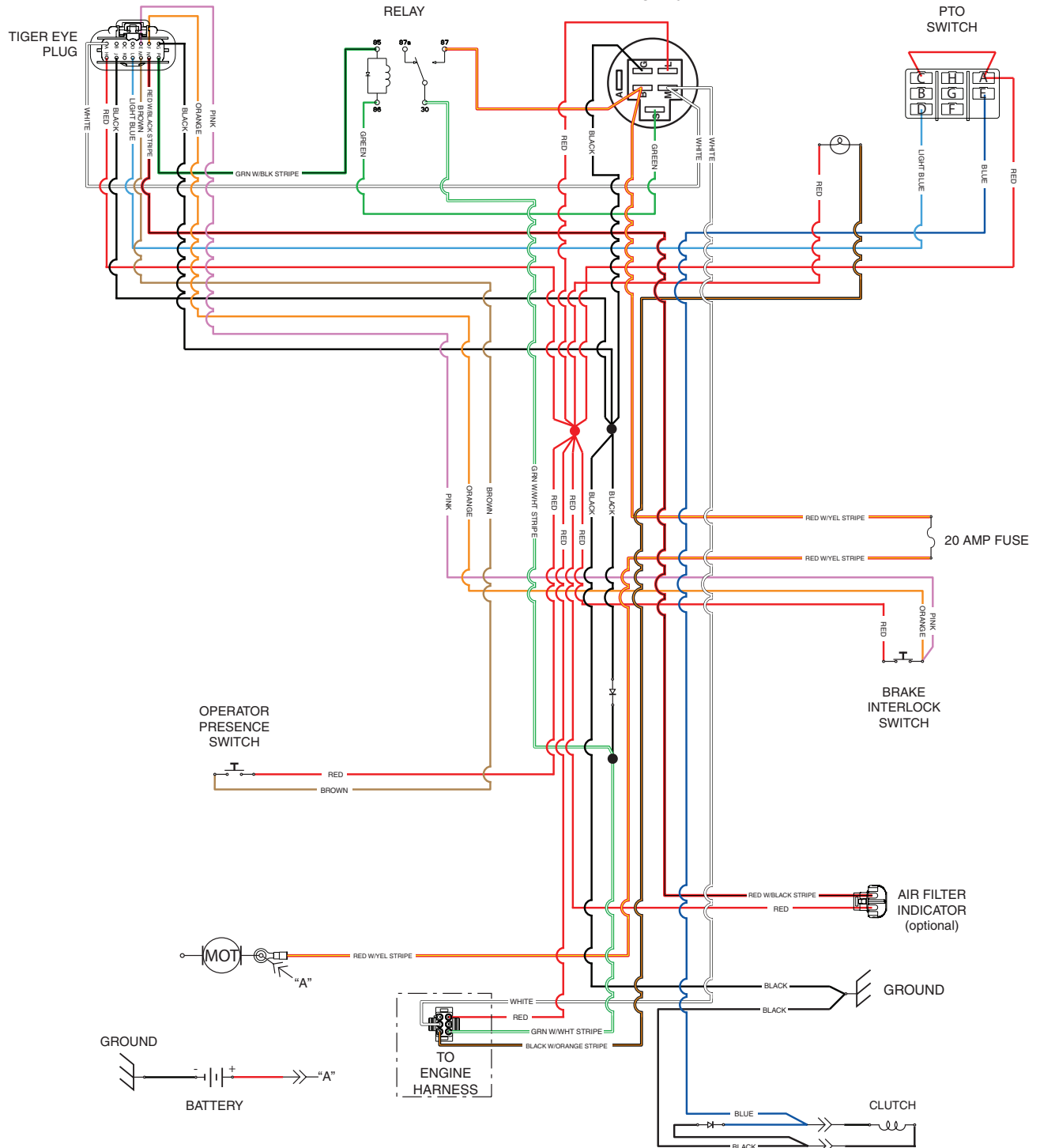

KAWASAKI ENGINE ADAPTER ELECTRICAL SCHEMATIC

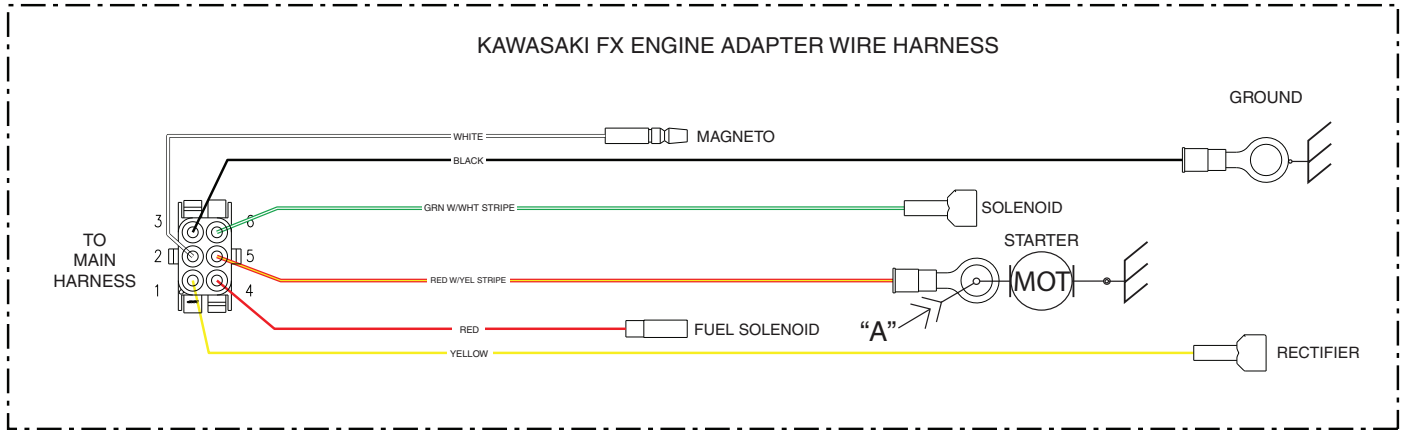

LIMITED WARRANTY - COMMERCIAL EQUIPMENT

Any part of the Scag commercial mower manufactured by Scag Power Equipment and found, in the reasonable judgment of Scag, to be defective in materials or workmanship, will be repaired or replaced by an Authorized Scag Service Dealer without charge for parts and labor during the periods specified below. This warranty is limited to the original purchaser provided the product was purchased from an Authorized Scag Power Equipment Dealer and is not transferable. Proof of purchase will be required by the dealer to substantiate any warranty claims. All warranty work must be performed by an Authorized Scag Service Dealer.

This warranty is limited to the following specified periods from the date of the original retail purchase for defects in materials or workmanship:

- Wear items including drive belts, blades, hydraulic hoses and tires are warranted for ninety (90) days.
- Batteries are covered for ninety (90) days.
- Frame and structural components including oil reservoir and oil coolers are warranted for two (2) years (parts and labor) for commercial use or three (3) years / 500 hours (whichever comes first) (parts and labor) for non-commercial use.
- Cutter decks are warranted against cracking for a period of three (3) years. (parts and labor 1st and 2nd year; parts only 3rd year.) The repair or replacement of the cutter deck will be at the option of Scag Power Equipment. We reserve the right to request components for evaluation. This warranty does not cover any mower that has been subject to misuse, neglect, negligence, or accident, or that has been operated in any way contrary to the operating instructions as specified in the Operator's Manual.
- Engines and electric starters are covered by the engine manufacturer's warranty period.
- Major drive system components are warranted for two (2) years (parts and labor) for commercial use or three (3) year / 500 hour (whichever comes first) (parts and labor) for non-commercial use by Scag Power Equipment. (commercial and non-commercial warranty excludes fittings, hoses, drive belts). The repair or replacement of the hydraulic pump or hydraulic motor will be at the option of Scag Power Equipment. This warranty does not cover any mower that has been subject to misuse, neglect, negligence, or accident, or that has been operated in any way contrary to the operating instructions as specified in the Operator's Manual.
- Electric clutches have a Limited Warranty for two (2) years (parts and labor) for commercial use or three (3) year / 500 hours (whichever comes first) (parts and labor) for non-commercial use.
- Spindle assemblies have a Limited Warranty for three years (parts and labor 1st year and 2nd; parts only 3rd year).
- Any Scag product used for rental purposes is covered by a 90 day warranty.

The Scag mower, including any defective part must be returned to an Authorized Scag Service Dealer within the warranty period. The expense of delivering the mower to the dealer for warranty work and the expense of returning it to the owner after repair will be paid for by the owner. Scag's responsibility is limited to making the required repairs and no claim of breach of warranty shall be cause for cancellation or rescission of the contract of sale of any Scag mower. "Non-Commercial" use is defined as a single property owner, where the single property is the residence of the owner of the mower. If the mower is cutting more than the owners single property, it is deemed commercial use and the "non-commercial" warranty does not apply. Scag Power Equipment reserves the right to deny and / or void the non-commercial warranty if it believes it to be in commercial use.

This warranty does not cover any mower that has been subject to misuse, neglect, negligence, or accident, or that has been operated in any way contrary to the operating instructions as specified in the Operator's Manual. The warranty does not apply to any damage to the mower that is the result of improper maintenance, or to any mower or parts that have not been assembled or installed as specified in the Operator's Manual and Assembly Manual. The warranty does not cover any mower that has been altered or modified, changing performance or durability. In addition, the warranty does not extend to repairs made necessary by normal wear, or by the use of parts or accessories which, in the reasonable judgment of Scag, are either incompatible with the Scag mower or adversely affect its operation, performance or durability.

Scag Power Equipment reserves the right to change or improve the design of any mower without assuming any obligation to modify any mower previously manufactured. All other implied warranties are limited in duration to the two (2) year for commercial use, three (3) years / 500 hour for non-commercial use or ninety (90) days for mowers used for rental purpose. Accordingly, any such implied warranties including merchantability, fitness for a particular purpose, or otherwise, are disclaimed in their entirety after the expiration of the appropriate two (2) year for commercial use, three (3) years / 500 hour for non-commercial use or ninety day warranty period. Scag's obligation under this warranty is strictly and exclusively limited to the repair or replacement of defective parts and Scag does not assume or authorize anyone to assume for them any other obligation. Some states do not allow limitations on how long an implied warranty lasts, so the above limitation may not apply to you.

Scag assumes no responsibility for incidental, consequential or other damages including, but not limited to, expense for gasoline, expense of delivering the mower to an Authorized Scag Service Dealer and expense of returning it to the owner, mechanic's travel time, telephone or telegram charges, rental of a like product during the time warranty repairs are being performed, travel, loss or damage to personal property, loss of revenue, loss of use of the mower, loss of time or inconvenience. Some states do not allow the exclusion or limitation of incidental or consequential damages, so the above limitation or exclusion may not apply to you. This warranty gives you specific legal rights, and you may also have other rights which vary from state to state.

